

wilwood
DISC BRAKES

Wilwood Disc Brakes Technical & Parts Guide



R750 12 PL.
EQUALLY SPACED ON
A (07.960) B.C.

www.wilwood.com
Braking Solutions for a World in Motion™

wilwood

Welcome to Wilwood's 2013 Technical and Parts Guide, highlighting individual disc brake calipers, brake pads, rotors, hats, hubs, pedals, master cylinders, fluids, controls and other related components. Also included is an overview of our extensive range of bolt-on disc brake kits.

Throughout this guide you will notice QR codes which are readable with the scan function on your Smartphone. For example, this QR code takes you to our home page and social media sites.



The 2013 Technical and Parts Guide highlights just a fraction of what we have to offer. For the most complete and up-to-date listing of Wilwood Disc Brake products, including an easy to use Year-Make-Model search engine for more than 3,000 vehicle brake kit applications, visit the Wilwood web site portal at:

www.wilwood.com

Wilwood's totally redesigned and expanded web site is the most comprehensive in the automotive industry. It's extraordinarily easy to find the right Wilwood product using the improved part number or item description look up capabilities, thus enabling you to locate the product you need with just the click of a mouse.



To begin, go to www.wilwood.com. Search our individual brake components through our Product Center Page, or find the perfect bolt-on brake kit for your particular application using our Year, Make, and Model search engine located within the "Bolt-on Brake Kits" drop down menu. Simply fill out the Vehicle Search fields in the upper section of the page and hit search. Detailed isometric parts drawings, installation instructions, components, and accessories for your kit are all at your fingertips. You can also enter a product part number or brief description in the box in the top right hand corner and press "Go" and you will be taken directly to that item.

If you need additional product assistance, call our Customer Service Department at (805) 388-1188 where a knowledgeable technical representative will help you select the brake kit or component for your application.

Introduction

Wilwood's Technical and Parts Guide represents our current "in stock" product line, however we are constantly adding new products. If you have a disc brake application that is not included, please visit our web site at www.wilwood.com, e-mail us at support@wilwood.com, or call us Monday through Friday, 7:30 A.M. - 5:00 P.M. PST at (805) 388-1188.

CALIPER COLORS

Wilwood calipers come in a variety of colors and finishes. Calipers for racing and off-highway environments are generally matte black anodized; calipers for street performance and aftermarket applications are generally gloss black powder coat. Red powder coat is an available option in most cases. Other standard finishes on select Wilwood calipers include blue, yellow, and silver powder coat, and our exclusive "Quick-Silver" finish, all available by special order on select calipers at additional cost. Custom colors are also offered by Wilwood. Contact us for more information.

WARNING

IT IS THE RESPONSIBILITY OF THE PERSON INSTALLING ANY BRAKE COMPONENT OR KIT TO DETERMINE THE SUITABILITY OF THE COMPONENT OR KIT FOR THAT PARTICULAR APPLICATION. IF YOU ARE NOT SURE HOW TO SAFELY USE THIS BRAKE COMPONENT OR KIT, YOU SHOULD NOT INSTALL OR USE IT. DO NOT ASSUME ANYTHING. IMPROPERLY INSTALLED OR MAINTAINED BRAKES ARE DANGEROUS. IF YOU ARE NOT SURE, GET HELP OR RETURN THE PRODUCT. YOU MAY OBTAIN ADDITIONAL INFORMATION AND TECHNICAL SUPPORT BY CALLING WILWOOD AT (805) 388-1188, OR VISIT OUR WEB SITE AT WWW.WILWOOD.COM. USE OF WILWOOD TECHNICAL SUPPORT DOES NOT GUARANTEE PROPER INSTALLATION. **YOU**, OR THE PERSON WHO DOES THE INSTALLATION MUST KNOW HOW TO PROPERLY USE THIS PRODUCT. IT IS NOT POSSIBLE OVER THE PHONE TO UNDERSTAND OR FORESEE ALL THE ISSUES THAT MIGHT ARISE IN YOUR INSTALLATION.

RACING EQUIPMENT AND BRAKES MUST BE MAINTAINED AND SHOULD BE CHECKED REGULARLY FOR FATIGUE, DAMAGE, AND WEAR.

DOT APPROVAL FOR HIGHWAY USE

With the exception of brake hoses and brake fluid, there are no State or Federal DOT specifications regarding the materials, processes, or style for the other components within a brake system. Specifications that would regulate calipers, rotors, hats, hubs, brake pads, and the other individual components within the brake system do not exist. It is the responsibility of the vehicle manufacturer to configure a vehicle's brake system to perform within Federal Motor Vehicle Safety Standards. It is therefore NOT accurate to identify any brake system component other than hoses or fluid as "DOT approved".

WARNING • DO NOT DRIVE ON UNTESTED BRAKES BRAKES MUST BE TESTED AFTER INSTALLATION OR MAINTENANCE MINIMUM TEST PROCEDURE

- Make sure pedal is firm: Hold firm pressure on pedal for several minutes, it should remain in position without sinking. If pedal sinks toward floor, check system for fluid leaks. DO NOT drive vehicle if pedal does not stay firm or can be pushed to the floor with normal pressure.
- At very low speed (2-5 mph) apply brakes hard several times while turning steering from full left to full right, repeat several times. Remove the wheels and check that components are not touching, rubbing, or leaking.
- Carefully examine all brake components, brake lines, and fittings for leaks and interference.
- Make sure there is no interference with wheels or suspension components.
- Drive vehicle at low speed (15-20 mph) making moderate and hard stops. Brakes should feel normal and positive. Again check for leaks and interference.
- Always test vehicle in a safe place where there is no danger to (or from) other people or vehicles.
- Always wear seat belts and make use of all safety equipment.

Table of Contents

Calipers Pages 2-22

Grand National GN III	2
Forged TC6R	2
W6AR/ST • W4AR/ST Radial Mount	3
Billet Superlite 6R Radial Mount	4
Billet Superlite 6 Lug Mount	4
Billet Superlite 4 Radial and Lug Mount	5
Forged Superlite FSLI/ST	5
Forged Narrow SL6R • SL4R/ST Radial Mount	6
GNX4 Off-Road	6
D8-6 / D8-4	7
GM D52 Dual Piston	8
GM III	8
GM D154 Metric	9
Aluminum GM Metric Racing	9
Cast Iron GM Metric	9
DynaPro, DynaPro-13 Radial Mount DPR	10
Billet Narrow DYNALITE Radial Mount	10
Billet Narrow Mount DynaPro, NDP	11
Billet Narrow Radial Mount DynaPro, NDPR	11
DynaPro 6 Lug Mount, DP6	12
DynaPro Lug Mount, DP	12
DynaPro Lug Mount, DP with Dust Boots	13
Forged DynaPro Lug Mount, DP Low-Profile	13
Forged Narrow Mount DYNALITE, FNDL	14
Forged Billet DYNALITE, FDL	14
Billet Powerlite	15
Combination Parking Brake, CPB	15
Billet DynaPro Single, DPS	16
Billet DYNALITE Single, DLS	16
GP 320	16
DYNALITE Single Floater	17
Billet Spot	17
Kart / Jr. Dragster	18
PS-1	18
GP 200	18
SC-10 Two Piston Floating	19
MC4 Mechanical Parking Brake	19
SC Caliper Series	20
DH4	20
Hydra-Mechanical	20
Motorcycle GP Series (including rotors)	21

Thermlock® Pistons Page 23

T1 Thermlock® Pistons	23
---------------------------------	----

Brake Pads Pages 24-25

Pad Compound and Reference Guides	24
Brake Pad Bedding	25

Rotors Pages 26-36

SV-GT Staggered Directional Vane	26
GT-32 / 36 / 40 / 48 Curved Vane	27
HD Series Directional Vane	28
UL-32 Series Directional Vane	28
UL Series Straight Vane	29
ULD-32 Drilled Straight Vane Vented Iron	29
ULS-32 Scalloped Vented Iron	30
Super Alloy	30
C / SiC (Carbon-Ceramic)	31
OEM Replacement Rotors for Modifieds	31
Standard Hole Mount Steel	32
Dynamic Mount Drilled Steel	32
Aluminum Sprint / Midget	33
Rotor Bedding	33
SRP Drilled and Slotted Performance	34
SRP Disc / Drum Internal Parking Brake	35
GT Disc / Drum Internal Parking Brake	35
HP Disc / Drum Internal Parking Brake	36
Challenge Series	36

Rotor Mounting Hats/Plates Pages 37-41

Dynamic Rotor Mounting Systems	37
Dynamic Mount Rotor Plates	37
GT Series Dynamic Mount Rotor Hats	38
GT Series Fixed Mount Rotor Hats	38
HD Series Fixed Mount Rotor Hats	40
Fixed Mount Iron Hats for Parking Brake	41
Fixed Mount Steel Hats for Bolt-on Rotors	41
Sprint / Open Wheel Live Axle Clamp	41

Rotor Bolt Kits Page 42

Dynamic Mount Bolt Kits	42
Fixed Mount Bolt Kits	42
Hat / Rotor Registration Adapter Ring	42

Performance Hubs Pages 43-44

Forged Billet Street Performance Hubs	43
Rotor Adapters	44
Wheel Studs	44
Bolt Kits for Performance Hubs	44
Replacement Hub Caps	44

Wide 5 Hubs Pages 45-47

Starlite Wide 5	45
Starlite 55-XD Wide 5	45
Starlite "55"	46
Wide 5 Wheel Spacer	46
Wide 5 Hub Parts and Accessories	47



Table of Contents

Pedal Assemblies Pages 48-55

Floor Mount Triple Pedal Assembly	48
Adjustable Pedals	48
Adjustable Pedal Retrofit Kit	49
Floor Mount Pedals	50
Forward Swing Mount Pedals	50
Reverse Swing Mount Pedals	51
Clutch Pedal Kits	52
60 Degree Balance Pedal Assembly	53
Balance Bar Assembly	53
Remote Brake Bias Adjuster	53
Brake Pedal Guidelines	54
Balance Bar Adjusting	54
Pedal Ratios / Mechanical Leverage	55

Master Cylinders, Fluids & Controls Pages 56-67

Knob / Lever Style Proportioning Valves	56
Combination Proportioning Valve	57
GM Style Proportioning Valve	57
Line Shut-off Valve	58
Quick Check Pressure Gauge	58
Compact Combination Master Cylinder Kit	59
Combination Remote Master Cylinder Kit	60
High Volume Aluminum Master Cylinder	60
Detached Reservoir Compact Aluminum M/C	61
Integral Reservoir Compact Aluminum M/C	61
Aluminum Tandem Chamber Master Cylinder	62
Master Cylinder Bleeding Kit	62
Tandem Master Cylinder	63
Combination Remote Tandem Master Cylinder	63
TM1 Tandem Master Cylinder	64
Kart / Jr. Dragster Master Cylinder	64
Handle Bar Master Cylinder	65
Kart Master Cylinder (RM1) Replacement	65
Residual Pressure Valves	66
Clutch Slave Cylinder	66
Check Valve / Self Bleed Lines	66
EXP 600 Plus Brake Fluid	67
Hi-Temp° 570 Brake Fluid	67
DOT 5 "FIVE" Brake Fluid	67
Synthetic Assembly Lubricant	67

Plumbing Kits & Components . . Page 68

Stainless Braided Flexlines	68
Brake Line Fittings and Adapters	68

Steering Pages 69-70

Wilwood ProSpindle	69
Rack and Pinion	70
Quick Release Steering Wheel Hub	70

Street Performance Kits . . . Pages 71-80

Front Kits Overview	71
Rear Kits Overview	75

Drag Race Kits Pages 80-82

Front Kits Overview	80
Rear Kits Overview	81

Road Race Kits Pages 83-84

Front Kits Overview	83
Rear Kits Overview	84

Open Wheel Kits Pages 84-85

GP 320 Caliper Kits	84
DynaPro Caliper Kits	85

Motorcycle Kits Pages 85-86

GP 310 Caliper Kits	85
-------------------------------	----

Original Equipment Kits Page 86

GNX4 Front / Rear Caliper Kits	86
--	----

Trouble Shooting Pages 87-88

Most Common Items Highlighted	87
---	----

Technical Tips Pages 89-90

Some Interesting Things Discussed	89
---	----

Warnings Page 91

Disclaimer of Warranty	91
----------------------------------	----



Calipers

GN III Calipers

- Either 3.50" or 6.00" mounts available
- Unique six-piston configuration that generates high clamping force with balanced loading for even pad wear
- Uses larger 7520 pad for longer wear and additional heat resistance
- Can run with either a 1.25" or 1.38" thick rotor
- Caliper comes standard in a black anodized finish

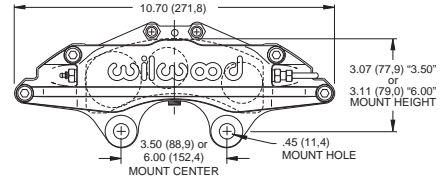

Caliper Ordering Information

PART NUMBER	DESCRIPTION	BORE SIZE	DISC WIDTH	PAD PLATE	PAD PLATE 7520 PHYSICAL CHARACTERISTICS				
					PAD P/N	PAD MAT'L	PAD P/N	PAD MAT'L	
3.50" Mount						15A-5936K	PolyMatrix A	150-9425K	BP-10
120-6478-RS	6 Piston Lug Mount - R/H	1.75 / 1.38 / 1.38"	1.38"	7520		15B-3993K	PolyMatrix B	150-9417K	BP-20
120-6479-RS	6 Piston Lug Mount - L/H	1.75 / 1.38 / 1.38"	1.38"	7520	15E-6101K	PolyMatrix E	150-12246K	BP-40	
6.00" Mount						15Q-6879K	PolyMatrix Q		
120-3030-RS	6 Piston Lug Mount - R/H	1.75 / 1.38 / 1.38"	1.38"	7520					
120-3031-RS	6 Piston Lug Mount - L/H	1.75 / 1.38 / 1.38"	1.38"	7520					

NOTE:

FS = Front side mount • RS = Rear side mount

TC6R Forged Radial Mount Calipers

- Extremely lightweight for a caliper of this magnitude, just 8.66 pounds
- Easily accommodates 1.38" thick rotors up to a full 16 inches in diameter.
- Six stainless steel pistons to resist corrosion and reduce the heat transferred from the pads to the caliper body
- Standard black powder finish, red or other Wilwood colors available

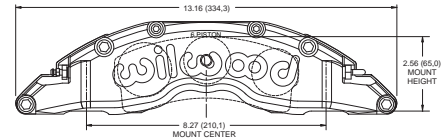

Caliper Ordering Information

PART NUMBER	DESCRIPTION	BORE SIZE	DISC WIDTH	PAD PLATE	PAD PLATE 6318 PHYSICAL CHARACTERISTICS				
					PAD P/N	PAD MAT'L	PAD P/N	PAD MAT'L	
120-8909-RS ⁽¹⁾	6 Piston Radial Mount - R/H	1.88 / 1.62 / 1.62"	1.38"	6318		15Q-8823K	PolyMatrix Q	150-9411K	BP-20
120-8910-RS ⁽¹⁾	6 Piston Radial Mount - L/H	1.88 / 1.62 / 1.62"	1.38"	6318		15Q-9118K	BP-10		
120-8907-FS ⁽¹⁾	6 Piston Radial Mount - R/H	1.75 / 1.38 / 1.38"	1.38"	6318					
120-8907-RS ⁽¹⁾	6 Piston Radial Mount - R/H	1.75 / 1.38 / 1.38"	1.38"	6318					
120-8908-FS ⁽¹⁾	6 Piston Radial Mount - L/H	1.75 / 1.38 / 1.38"	1.38"	6318					
120-8908-RS ⁽¹⁾	6 Piston Radial Mount - L/H	1.75 / 1.38 / 1.38"	1.38"	6318					
120-9138-RS ⁽¹⁾	6 Piston Radial Mount - R/H	1.62 / 1.12 / 1.12"	1.25"	6318					
120-9139-RS ⁽¹⁾	6 Piston Radial Mount - L/H	1.62 / 1.12 / 1.12"	1.25"	6318					

NOTES:

(1) Available red, add -R to end of part number.
FS = Front side mount • RS = Rear side mount

Calipers

W6AR / ST and W4AR / ST Radial Mount Calipers

- Calipers are the product of FEA computer design and only weigh 7.50 pounds
- Available in differential bore or standard symmetrical bore piston configurations
- Fits rotors from 12.19" to 15.00" in diameter, and widths from 1.10" to 1.25"
- Standard finish is black or red powder coat



W6AR Shown in Quick-Silver Finish

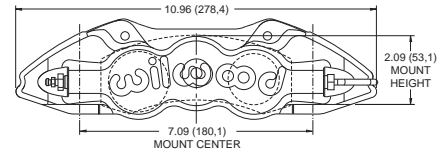

Caliper Ordering Information

PART NUMBER	DESCRIPTION	BORE SIZE	DISC WIDTH	PAD PLATE	PAD PLATE 6617 PHYSICAL CHARACTERISTICS																					
					Diagram	Table																				
W6AR with Stainless Pistons																										
120-11661-RS ⁽¹⁾	6 Piston Radial Mount - R/H	1.75 / 1.38 / 1.38"	1.25"	6617		<table border="1"> <thead> <tr> <th>PAD P/N</th> <th>PAD MAT'L</th> <th>PAD P/N</th> <th>PAD MAT'L</th> </tr> </thead> <tbody> <tr> <td>15A-9977K</td> <td>PolyMatrix A</td> <td>150-9489K</td> <td>BP-20</td> </tr> <tr> <td>15B-9978K</td> <td>PolyMatrix B</td> <td>150-9980K</td> <td>BP-30</td> </tr> <tr> <td>15H-9979K</td> <td>PolyMatrix H</td> <td>150-12251K</td> <td>BP-40</td> </tr> <tr> <td>150-9488K</td> <td>BP-10</td> <td></td> <td></td> </tr> </tbody> </table>	PAD P/N	PAD MAT'L	PAD P/N	PAD MAT'L	15A-9977K	PolyMatrix A	150-9489K	BP-20	15B-9978K	PolyMatrix B	150-9980K	BP-30	15H-9979K	PolyMatrix H	150-12251K	BP-40	150-9488K	BP-10		
PAD P/N	PAD MAT'L	PAD P/N	PAD MAT'L																							
15A-9977K	PolyMatrix A	150-9489K	BP-20																							
15B-9978K	PolyMatrix B	150-9980K	BP-30																							
15H-9979K	PolyMatrix H	150-12251K	BP-40																							
150-9488K	BP-10																									
120-11662-RS ⁽¹⁾	6 Piston Radial Mount - L/H	1.75 / 1.38 / 1.38"	1.25"	6617																						
120-11663-RS ^(1, 4)	6 Piston Radial Mount - R/H	1.62 / 1.12 / 1.12"	1.25"	6617																						
120-11664-RS ^(1, 4)	6 Piston Radial Mount - L/H	1.62 / 1.12 / 1.12"	1.25"	6617																						
W6AR/ST w/Thermlock Pistons																										
120-11657-RSN	6 Piston Radial Mount - R/H	1.62 / 1.12 / 1.12"	1.25"	6617																						
120-11658-RSN	6 Piston Radial Mount - L/H	1.62 / 1.12 / 1.12"	1.25"	6617																						
W4AR with Stainless Pistons																										
120-11665-FS ⁽¹⁾	4 Piston Radial Mount - R/H	1.88 / 1.62"	1.25"	6617																						
120-11666-FS ⁽¹⁾	4 Piston Radial Mount - L/H	1.88 / 1.62"	1.25"	6617																						
120-11665-RS ⁽¹⁾	4 Piston Radial Mount - R/H	1.88 / 1.62"	1.25"	6617																						
120-11666-RS ⁽¹⁾	4 Piston Radial Mount - L/H	1.88 / 1.62"	1.25"	6617																						
120-11667-FS ⁽¹⁾	4 Piston Radial Mount - R/H	1.62 / 1.38"	1.25"	6617																						
120-11667-FS ⁽¹⁾	4 Piston Radial Mount - L/H	1.62 / 1.38"	1.25"	6617																						
120-11667-RS ⁽¹⁾	4 Piston Radial Mount - R/H	1.62 / 1.38"	1.25"	6617																						
120-11668-RS ⁽¹⁾	4 Piston Radial Mount - L/H	1.62 / 1.38"	1.25"	6617																						
120-11659 ^(2, 3, 4)	4 Piston Radial Mount - R/H	1.25 / 1.25"	1.10"	6617																						
120-11660 ^(2, 3, 4)	4 Piston Radial Mount - L/H	1.25 / 1.25"	1.10"	6617																						
120-11669 ^(2, 3, 4)	4 Piston Radial Mount - R/H	1.12 / 1.12"	1.10"	6617																						
120-11670 ^(2, 3, 4)	4 Piston Radial Mount - L/H	1.12 / 1.12"	1.10"	6617																						
W4AR/ST w/Thermlock Pistons																										
120-11671-RS ^(1, 4)	4 Piston Radial Mount - R/H	1.75 / 1.38"	1.25"	6617																						
120-11672-RS ^(1, 4)	4 Piston Radial Mount - L/H	1.75 / 1.38"	1.25"	6617																						

(1) Available red, add -R to end of part number. • (2) Available red, add -RD to end of part number. • (3) For standard black calipers, add -BK to end of part number. (4) Available Quick-Silver, add -N to end of part number. • FS = Front side mount • RS = Rear side mount

Technical Tip

Caliper Selection and Mounting

Most Wilwood calipers are unidirectional because of the **differential piston bore design** (one end of the caliper having larger pistons than the other); the caliper must be mounted in a specific position relative to the rotor rotation. All Wilwood differential bore calipers are marked with a rotor rotation arrow on them. The caliper should be mounted so that the smaller piston end is closest to the rotor entrance and the larger piston end toward the rotor exit. The larger piston end provides slightly greater clamping force to compensate for pad taper that can occur under extended severe use applications. An improperly mounted caliper (reverse rotation) will cause increased pad taper and reduce overall braking efficiency.

Note that differential bore calipers cannot be used interchangeably from side to side - there is a left hand caliper and a right hand caliper. Also, calipers differ depending on whether the mounting is behind or in front of the spindle - this affects bleed screw position. Make sure to properly analyze these criteria when ordering and mounting or replacing differential bore calipers.

Calipers

Billet Superlite 6R Radial Mount Calipers

- Lightweight, starting at just 4.84 pounds
- Finished in black anodize to withstand high heat and resist corrosion
- Unique six piston differential bore configuration for even pad wear
- Utilizes a 4.9 cubic inch type 7420 pad available in numerous Wilwood compounds

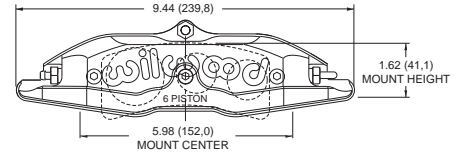

Caliper Ordering Information

PART NUMBER	DESCRIPTION	BORE SIZE	DISC WIDTH	PAD PLATE	PAD PLATE 7420 PHYSICAL CHARACTERISTICS																														
					4.74 (120,4)	2.43 (61,7)	.80 (20,3)																												
120-6111-RS ⁽²⁾	SL6R with Stainless Pistons 6 Piston Radial Mount - R/H	1.62 / 1.12 / 1.12"	0.81"	7420			<table border="1"> <thead> <tr> <th>PAD P/N</th> <th>PAD MAT'L</th> <th>PAD P/N</th> <th>PAD MAT'L</th> </tr> </thead> <tbody> <tr> <td>15A-5938K</td> <td>PolyMatrix A</td> <td>150-8854K</td> <td>BP-10</td> </tr> <tr> <td>15B-5939K</td> <td>PolyMatrix B</td> <td>150-9416K</td> <td>BP-20</td> </tr> <tr> <td>15C-6853K</td> <td>PolyMatrix C</td> <td>150-9864K</td> <td>BP-30</td> </tr> <tr> <td>15E-6084K</td> <td>PolyMatrix E</td> <td>150-12245K</td> <td>BP-40</td> </tr> <tr> <td>15H-8114K</td> <td>PolyMatrix H</td> <td>150-8323K</td> <td>CM</td> </tr> <tr> <td>15Q-6829K</td> <td>PolyMatrix Q</td> <td></td> <td></td> </tr> </tbody> </table>	PAD P/N	PAD MAT'L	PAD P/N	PAD MAT'L	15A-5938K	PolyMatrix A	150-8854K	BP-10	15B-5939K	PolyMatrix B	150-9416K	BP-20	15C-6853K	PolyMatrix C	150-9864K	BP-30	15E-6084K	PolyMatrix E	150-12245K	BP-40	15H-8114K	PolyMatrix H	150-8323K	CM	15Q-6829K	PolyMatrix Q		
PAD P/N	PAD MAT'L	PAD P/N	PAD MAT'L																																
15A-5938K	PolyMatrix A	150-8854K	BP-10																																
15B-5939K	PolyMatrix B	150-9416K	BP-20																																
15C-6853K	PolyMatrix C	150-9864K	BP-30																																
15E-6084K	PolyMatrix E	150-12245K	BP-40																																
15H-8114K	PolyMatrix H	150-8323K	CM																																
15Q-6829K	PolyMatrix Q																																		
120-6112-RS ⁽²⁾	6 Piston Radial Mount - L/H	1.62 / 1.12 / 1.12"	0.81"	7420																															
120-6201-SI	SL6R/ST with Thermlock Pistons 6 Piston Radial Mount-Side Inlet-L/H	1.62 / 1.12 / 1.12"	1.25"	7420																															
120-7761-RS	SL6R w/Stainless Pistons 6 Piston Radial Mount - R/H	1.62 / 1.12 / 1.12"	1.25"	7420																															
120-7762-RS	6 Piston Radial Mount - L/H	1.62 / 1.12 / 1.12"	1.25"	7420																															
120-6385-RS	SL6R/ST with Thermlock Pistons 6 Piston Radial Mount - R/H	1.62 / 1.12 / 1.12"	1.25"	7420																															
120-6386-RS	6 Piston Radial Mount - L/H	1.62 / 1.12 / 1.12"	1.25"	7420																															

NOTES:

(1) Available red, add -R to end of part number. • (2) These calipers may also be used with 1.10" rotors and 7416 type 16mm thick brake pads.
FS = Front side mount • RS = Rear side mount • SI = Side Inlet

Billet Superlite 6 Lug Mount Calipers

- Lightweight, starting at just 5.06 pounds
- Standard and narrow width option for virtually every application
- Black anodized to provide a durable long lasting finish
- Fits rotors from 11.75" to 13.00" in diameter, and widths from .81" to 1.25"

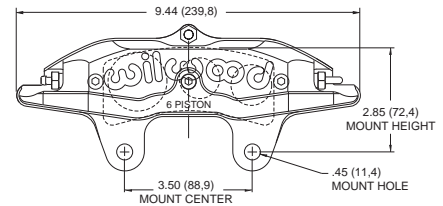

Caliper Ordering Information

PART NUMBER	DESCRIPTION	BORE SIZE	DISC WIDTH	PAD PLATE	PAD PLATE 7416 / 7420 PHYSICAL CHARACTERISTICS																																																						
					4.74 (120,4)	2.43 (61,7)	.65 (16,5) TYPE 7416 .80 (20,3) TYPE 7420																																																				
120-6584-FS	SL6 with Stainless Pistons 6 Piston Lug Mount - R/H	1.62 / 1.12 / 1.12"	1.25"	7420			<table border="1"> <thead> <tr> <th colspan="2">PAD PLATE 7416</th> <th colspan="2">PAD PLATE 7420</th> </tr> <tr> <th>PAD P/N</th> <th>PAD MAT'L</th> <th>PAD P/N</th> <th>PAD MAT'L</th> </tr> </thead> <tbody> <tr> <td>15A-6704K</td> <td>PolyMatrix A</td> <td>15A-5938K</td> <td>PolyMatrix A</td> </tr> <tr> <td>15B-6705K</td> <td>PolyMatrix B</td> <td>15B-5939K</td> <td>PolyMatrix B</td> </tr> <tr> <td>15E-6707K</td> <td>PolyMatrix E</td> <td>15C-6853K</td> <td>PolyMatrix C</td> </tr> <tr> <td>15H-8546K</td> <td>PolyMatrix H</td> <td>15E-6084K</td> <td>PolyMatrix E</td> </tr> <tr> <td>15Q-6828K</td> <td>PolyMatrix Q</td> <td>15H-8114K</td> <td>PolyMatrix H</td> </tr> <tr> <td>150-8855K</td> <td>BP-10</td> <td>15Q-6829K</td> <td>PolyMatrix Q</td> </tr> <tr> <td>150-9415K</td> <td>BP-20</td> <td>150-8854K</td> <td>BP-10</td> </tr> <tr> <td>150-12244K</td> <td>BP-40</td> <td>150-9416K</td> <td>BP-20</td> </tr> <tr> <td></td> <td></td> <td>150-9864K</td> <td>BP-30</td> </tr> <tr> <td></td> <td></td> <td>150-12245K</td> <td>BP-40</td> </tr> <tr> <td></td> <td></td> <td>150-8323K</td> <td>CM</td> </tr> </tbody> </table>	PAD PLATE 7416		PAD PLATE 7420		PAD P/N	PAD MAT'L	PAD P/N	PAD MAT'L	15A-6704K	PolyMatrix A	15A-5938K	PolyMatrix A	15B-6705K	PolyMatrix B	15B-5939K	PolyMatrix B	15E-6707K	PolyMatrix E	15C-6853K	PolyMatrix C	15H-8546K	PolyMatrix H	15E-6084K	PolyMatrix E	15Q-6828K	PolyMatrix Q	15H-8114K	PolyMatrix H	150-8855K	BP-10	15Q-6829K	PolyMatrix Q	150-9415K	BP-20	150-8854K	BP-10	150-12244K	BP-40	150-9416K	BP-20			150-9864K	BP-30			150-12245K	BP-40			150-8323K	CM
PAD PLATE 7416		PAD PLATE 7420																																																									
PAD P/N	PAD MAT'L	PAD P/N	PAD MAT'L																																																								
15A-6704K	PolyMatrix A	15A-5938K	PolyMatrix A																																																								
15B-6705K	PolyMatrix B	15B-5939K	PolyMatrix B																																																								
15E-6707K	PolyMatrix E	15C-6853K	PolyMatrix C																																																								
15H-8546K	PolyMatrix H	15E-6084K	PolyMatrix E																																																								
15Q-6828K	PolyMatrix Q	15H-8114K	PolyMatrix H																																																								
150-8855K	BP-10	15Q-6829K	PolyMatrix Q																																																								
150-9415K	BP-20	150-8854K	BP-10																																																								
150-12244K	BP-40	150-9416K	BP-20																																																								
		150-9864K	BP-30																																																								
		150-12245K	BP-40																																																								
		150-8323K	CM																																																								
120-6585-FS	6 Piston Lug Mount - L/H	1.62 / 1.12 / 1.12"	1.25"	7420																																																							
120-6584-RS	6 Piston Lug Mount - R/H	1.62 / 1.12 / 1.12"	1.25"	7420																																																							
120-6585-RS	6 Piston Lug Mount - L/H	1.62 / 1.12 / 1.12"	1.25"	7420																																																							
120-6387-RS	SL6/ST with Thermlock Pistons 6 Piston Lug Mount - R/H	1.62 / 1.12 / 1.12"	1.25"	7420																																																							
120-6388-RS	6 Piston Lug Mount - L/H	1.62 / 1.12 / 1.12"	1.25"	7420																																																							
120-7228-RS ⁽¹⁾	Narrow Body SL6 for 16mm Pads 6 Piston Lug Mount - R/H	1.62 / 1.12 / 1.12"	1.10"	7416																																																							
120-7229-RS ⁽¹⁾	6 Piston Lug Mount - L/H	1.62 / 1.12 / 1.12"	1.10"	7416																																																							
120-7259-RSP	6 Piston Lug Mount - Polished - R/H	1.62 / 1.12 / 1.12"	1.10"	7416																																																							
120-7260-RSP	6 Piston Lug Mount - Polished - L/H	1.62 / 1.12 / 1.12"	1.10"	7416																																																							

NOTES:

(1) Available red, add -R to end of part number. • FS = Front side mount • RS = Rear side mount

Calipers

Billet Superlite 4 Radial & Lug Mount Calipers

- Extremely rigid, four piston design with weights starting at just 4.94 pounds
- Stainless steel pistons are standard, or for the ultimate protection in high heat competition select from the Thermlock piston line of calipers
- Utilizes a 4.9 cubic inch type 7420 pad available in numerous Wilwood compounds to match the brake response and heat range of any competition application
- Black anodized to withstand high heat situations and resist corrosion



Radial mount caliper photo with Thermlock pistons shown above

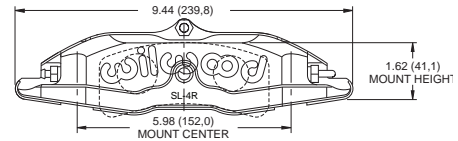

Radial mount caliper drawing upper right

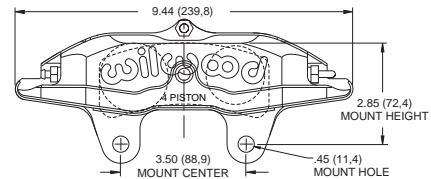

Lug mount caliper drawing lower right

Caliper Ordering Information

PART NUMBER	DESCRIPTION	BORE SIZE	DISC WIDTH	PAD PLATE	PAD PLATE 7420 PHYSICAL CHARACTERISTICS				
					PAD P/N	PAD MAT'L	PAD P/N	PAD MAT'L	
SL4R with Stainless Pistons									
120-10695-RS	4 Piston Radial Mount - R/H	1.88 / 1.62"	1.25"	7420		15A-5938K	PolyMatrix A	150-8854K	BP-10
120-10696-RS	4 Piston Radial Mount - L/H	1.88 / 1.62"	1.25"	7420		15B-5939K	PolyMatrix B	150-9416K	BP-20
120-10697-R	4 Piston Radial Mount - R/H	1.62 / 1.62"	1.25"	7420		15C-6853K	PolyMatrix C	150-9864K	BP-30
SL4R/ST with Thermlock Pistons									
120-10693-RS	4 Piston Radial Mount - R/H	1.88 / 1.62"	1.25"	7420	15E-6084K	PolyMatrix E	150-12245K	BP-40	
120-10694-RS	4 Piston Radial Mount - L/H	1.88 / 1.62"	1.25"	7420	15H-8114K	PolyMatrix H	150-8323K	CM	
SL4 with Stainless Pistons									
120-7568-RS	4 Piston Lug Mount - R/H	1.88 / 1.62"	1.25"	7420	15Q-6829K	PolyMatrix Q			
120-7569-RS	4 Piston Lug Mount - L/H	1.88 / 1.62"	1.25"	7420					
SL4/ST with Thermlock Pistons									
120-7570-RS	4 Piston Lug Mount - R/H	1.88 / 1.62"	1.25"	7420					
120-7571-RS	4 Piston Lug Mount - L/H	1.88 / 1.62"	1.25"	7420					

NOTES: Please visit our web site at www.wilwood.com for additional information on this caliper including the availability of service parts. Order at 805 • 388-1188. FS = Front side mount (available by special order) • RS = Rear side mount

Forged Superlite FSLI / ST Calipers

- Lightweight, starting at just 4.40 pounds
- Redesigned with internal fluid ports that eliminate the external fluid crossover tubes
- Available in differential bore or standard symmetrical bore configurations
- Fits rotors from 11.75" to 13.00" in diameter, and widths from .81" to 1.25"
- Black anodized to provide a durable long lasting finish

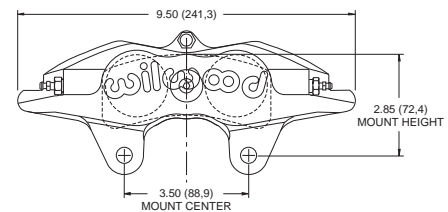

Caliper Ordering Information

PART NUMBER	DESCRIPTION	BORE SIZE	DISC WIDTH	PAD PLATE	PAD PLATE 7420 PHYSICAL CHARACTERISTICS				
					PAD P/N	PAD MAT'L	PAD P/N	PAD MAT'L	
120-11331 ⁽¹⁾	4 Piston Lug Mount - R/H	1.88 / 1.75"	1.25"	7420					
120-11332 ⁽¹⁾	4 Piston Lug Mount - L/H	1.88 / 1.75"	1.25"	7420		15A-5938K	PolyMatrix A	150-8323K	CM
120-11329	4 Piston Lug Mount - R/H	1.88 / 1.75"	1.25"	7420		15B-5939K	PolyMatrix B	150-8854K	BP-10
120-11330	4 Piston Lug Mount - L/H	1.88 / 1.75"	1.25"	7420		15C-6853K	PolyMatrix C	150-9416K	BP-20
120-11137	4 Piston Lug Mount - R/H	1.88 / 1.75"	0.81"	7420	15E-6084K	PolyMatrix E	150-9864K	BP-30	
120-11138	4 Piston Lug Mount - L/H	1.88 / 1.75"	0.81"	7420	15H-8114K	PolyMatrix H	150-12245K	BP-40	
120-11136	4 Piston Lug Mount	1.75 / 1.75"	1.25"	7420					
120-11135	4 Piston Lug Mount	1.75 / 1.75"	1.10"	7420					
120-11134	4 Piston Lug Mount	1.75 / 1.75"	0.81"	7420					
120-11134-SI	4 Piston Lug Mount - Side Inlet	1.75 / 1.75"	0.81"	7420					
120-11133	4 Piston Lug Mount	1.62 / 1.62"	1.25"	7420					
120-11132	4 Piston Lug Mount	1.62 / 1.62"	1.10"	7420					
120-11131	4 Piston Lug Mount	1.62 / 1.62"	0.81"	7420					
120-11130	4 Piston Lug Mount	1.38 / 1.38"	1.25"	7420					
120-11129	4 Piston Lug Mount	1.38 / 1.38"	1.10"	7420					
120-11128 ⁽²⁾	4 Piston Lug Mount	1.38 / 1.38"	0.81"	7420					
120-11127	4 Piston Lug Mount	1.25 / 1.25"	1.25"	7420					
120-11126	4 Piston Lug Mount	1.25 / 1.25"	0.81"	7420					
120-11125	4 Piston Lug Mount	1.12 / 1.12"	0.81"	7420					

NOTES:

- (1) Equipped with Wilwood's exclusive Thermlock® Short Track pistons to further reduce heat transfer from the pads to the caliper body, seals, and fluid.
 (2) Available red, add -RD to end of part number.

Calipers

Forged Narrow SL6R and SL4R / ST Radial Mount Calipers

- Forged narrow body designed specifically for tight clearance applications
- Stainless steel pistons are utilized for their low heat transfer properties and high resistance to corrosion
- Internal fluid passages - no external tubes
- Standard finish is black or red powder coat
- Only weighs 5.10 pounds



FNSL6R Shown in Quick-Silver Finish

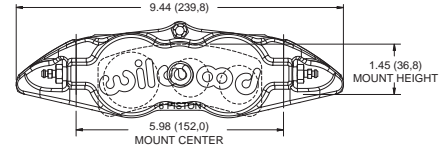

Caliper Ordering Information

PART NUMBER	DESCRIPTION	BORE SIZE	DISC WIDTH	PAD PLATE	PAD PLATE 7416 PHYSICAL CHARACTERISTICS																				
Forged Superlite 6 Calipers																									
120-11778-BK ^(1,3)	6 Piston Radial Mount - R/H	1.62 / 1.12 / 1.12"	1.25"	7416																					
120-11779-BK ^(1,3)	6 Piston Radial Mount - L/H	1.62 / 1.12 / 1.12"	1.25"	7416																					
120-11780-BK ^(1,3)	6 Piston Radial Mount - R/H	1.62 / 1.12 / 1.12"	1.10"	7416																					
120-11781-BK ^(1,3)	6 Piston Radial Mount - L/H	1.62 / 1.12 / 1.12"	1.10"	7416																					
120-12002-BK ⁽¹⁾	6 Piston Radial Mount - R/H	1.38 / 1.12 / 1.12"	1.10"	7416																					
120-12003-BK ⁽¹⁾	6 Piston Radial Mount - L/H	1.38 / 1.12 / 1.12"	1.10"	7416																					
Forged Superlite 4 Calipers																									
120-11784-BK ⁽¹⁾	4 Piston Radial Mount	1.75 / 1.75"	1.10"	7416																					
120-11783-BK ^(1,3)	4 Piston Radial Mount	1.25 / 1.25"	1.10"	7416																					
120-11782-BK ^(1,3)	4 Piston Radial Mount	1.12 / 1.12"	1.10"	7416																					
120-11876-BK ⁽¹⁾	4 Piston Radial Mount	1.12 / 1.12"	0.81"	7416																					
Forged Superlite 4 w/Thermlock Pistons																									
120-12602-N ⁽²⁾	4 Piston Radial Mount	1.25 / 1.25"	1.10"	7416	<table border="1"> <thead> <tr> <th>PAD P/N</th> <th>PAD MAT'L</th> <th>PAD P/N</th> <th>PAD MAT'L</th> </tr> </thead> <tbody> <tr> <td>15A-6704K</td> <td>PolyMatrix A</td> <td>15Q-6828K</td> <td>PolyMatrix Q</td> </tr> <tr> <td>15B-6705K</td> <td>PolyMatrix B</td> <td>150-8855K</td> <td>BP-10</td> </tr> <tr> <td>15E-6707K</td> <td>PolyMatrix E</td> <td>150-9415K</td> <td>BP-20</td> </tr> <tr> <td>15H-8546K</td> <td>PolyMatrix H</td> <td>150-12244K</td> <td>BP-40</td> </tr> </tbody> </table>	PAD P/N	PAD MAT'L	PAD P/N	PAD MAT'L	15A-6704K	PolyMatrix A	15Q-6828K	PolyMatrix Q	15B-6705K	PolyMatrix B	150-8855K	BP-10	15E-6707K	PolyMatrix E	150-9415K	BP-20	15H-8546K	PolyMatrix H	150-12244K	BP-40
PAD P/N	PAD MAT'L	PAD P/N	PAD MAT'L																						
15A-6704K	PolyMatrix A	15Q-6828K	PolyMatrix Q																						
15B-6705K	PolyMatrix B	150-8855K	BP-10																						
15E-6707K	PolyMatrix E	150-9415K	BP-20																						
15H-8546K	PolyMatrix H	150-12244K	BP-40																						
120-12603-N ⁽²⁾	4 Piston Radial Mount	1.12 / 1.12"	1.10"	7416																					

NOTES:

- (1) Calipers come standard in black, for red remove -BK and replace with -RD at end of part number.
- (2) Calipers come only in Quick-Silver finish.
- (3) Calipers come standard in black, for Quick-Silver remove -BK and replace with -N at end of part number.

GNX4 Forged Billet Off-Road Calipers

- Four corner bleed screws allow the caliper to be mounted in any front, rear, right, or left position
- Built for extreme off-road environments including deep mud, sand or rigorous mountain terrain
- Four dusted booted pistons provide optimum performance and ultimate reliability
- Internal fluid passages - no external tubes
- Clear anodized finish

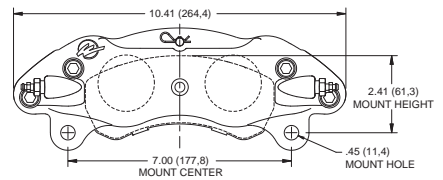

Caliper Ordering Information

PART NUMBER	DESCRIPTION	BORE SIZE	DISC WIDTH	PAD PLATE	PAD PLATE 9115 PHYSICAL CHARACTERISTICS				
120-10754	4 Piston Lug Mount	1.88 / 1.88"	1.00"	9115	<table border="1"> <thead> <tr> <th>PAD P/N</th> <th>PAD MAT'L</th> </tr> </thead> <tbody> <tr> <td>150-9841K</td> <td>CM</td> </tr> </tbody> </table>	PAD P/N	PAD MAT'L	150-9841K	CM
PAD P/N	PAD MAT'L								
150-9841K	CM								

Calipers

Forged Billet Aluminum D8-6 / D8-4 Corvette Calipers

- Direct replacement for the Original Equipment calipers on all 1965-82 Corvettes
- Mounts in the stock location over stock dimension rotors using the original D8 pads
- Forged billet aluminum bodies, stainless steel pistons and high-temperature seals put an end to the rust, bore pitting, seal failures, and the leaks that plague the original equipment caliper design
- A full set of calipers reduces unsprung suspension weight by 29 pounds (56%)
- Comes clear anodized, other Wilwood colors available



D8-6 front caliper photo shown

Front D8-6/4 caliper drawing upper right

Rear D8-4 caliper drawing lower right

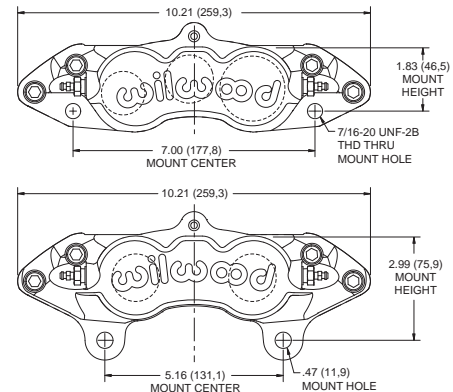

Caliper Ordering Information

PART NUMBER	DESCRIPTION	BORE SIZE	DISC WIDTH	PAD PLATE	PAD PLATE D8 PHYSICAL CHARACTERISTICS			
					PAD P/N		PAD MAT'L	
Front D8-6 / D8-4 Calipers								
120-11711 ^(1, 2)	6 Piston Lug Mount - R/H	1.88 / 1.38 / 1.25"	1.25"	D8				
120-11712 ^(1, 2)	6 Piston Lug Mount - L/H	1.88 / 1.38 / 1.25"	1.25"	D8				
120-10525 ^(1, 2)	4 Piston Lug Mount	1.88 / 1.88"	1.25"	D8				
120-10525-P	4 Piston Lug Mount - Polished	1.88 / 1.88"	1.25"	D8				
Rear D8-4 Calipers								
120-10526 ^(1, 2)	4 Piston Lug Mount	1.38 / 1.38"	1.25"	D8	15A-6202K	PolyMatrix A	150-10546K	BP-10
120-10526-P	4 Piston Lug Mount - Polished	1.38 / 1.38"	1.25"	D8	15E-8300K	PolyMatrix E	150-10547K	BP-20
					15Q-8623K	PolyMatrix Q		

NOTES:

Wheel clearance issues exist with Kelsey-Hayes knock-off wheels, and some aftermarket replica wheels. Always check wheel clearances closely prior to installation. If necessary, use a minimum thickness wheel spacer to provide adequate clearance.

(1) Available black powder coat, add -BK to end of part number. • (2) Available red powder coat, add -RD to end of part number.

Technical Tip

Caliper Piston Area

A caliper's piston area is calculated by finding the total piston area from one side of the caliper (this is true for a single piston caliper also). The graph provides the piston area for individual piston diameters. Note that differential piston bore calipers will be the total piston area of the different size pistons.

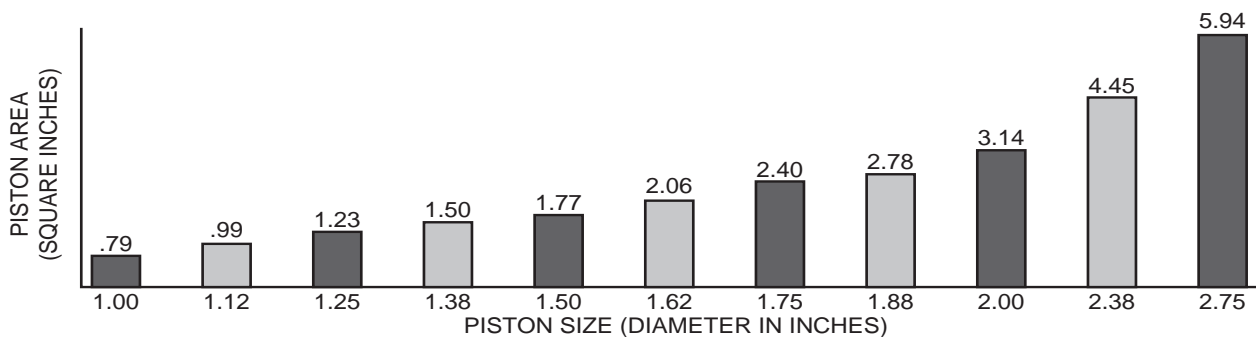

Example: For a typical six piston caliper (1.38", 1.38", 1.75" pistons), the effective piston area would be: 1.50" + 1.50" + 2.40" = 5.40 square inches.

Calipers

Forged Billet GM D52 Dual Piston Calipers

- Direct replacement for the single piston OE cast iron slide pin mount calipers used on many GM cars and trucks beginning in 1968
- Lightweight, only 5.5 pounds
- Inlet fitting: 7/16-20 banjo
- Forged billet bodies and FEA computer designed reinforced bridges make these the strongest aluminum replacement calipers available
- Accepts OE D52 brake pads
- Stainless steel pistons and high temperature "seal-in-bore" design run cooler and eliminate all problems associated with external dust boots seals
- Inlet port accepts OE 7/16-20 banjo bolt brake line fitting
- Available for 1.28" or 1.04" rotor widths in gloss black or red powder coat
- Applicable part numbers are listed below in **red**

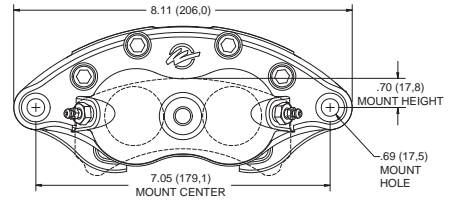

GM III Calipers

- Direct replacement for the single piston OE cast iron slide pin mount calipers used on many GM cars and trucks beginning in 1968 with D52 type pads
- Inlet fitting: 1/8-27 NPT
- Clear anodized, lightweight cast aluminum bodies starting at only 3.36 pounds
- Exclusive triple bridge design provides added resistance against deflection under hard braking
- Stainless steel pistons and high temperature "seal-in-bore" design run cooler and eliminate all problems associated with external dust boots seals
- Slide pin kit required, order part number 230-0619, 4 pack
- Applicable part number are listed below in **black**

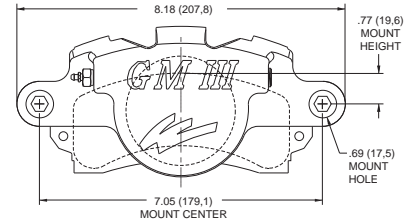

Caliper Ordering Information

PART NUMBER	DESCRIPTION	BORE SIZE	DISC WIDTH	PAD PLATE	PAD PLATE D52 PHYSICAL CHARACTERISTICS					
					Diagram 1	Diagram 2	PAD P/N	PAD MAT'L		
120-10936 ^(1, 2)	2 Piston Floating Mount	2.00 / 2.00"	1.28"	D52	<p>INNER PAD ABOVE, OUTER BELOW</p>		15A-5737K	PolyMatrix A	15Q-6830K	PolyMatrix Q
120-10937 ^(1, 2)	2 Piston Floating Mount	2.00 / 2.00"	1.04"	D52			15B-3994K	PolyMatrix B	150-8939K	BP-10
120-10938 ^(1, 2)	2 Piston Floating Mount	1.25 / 1.25"	1.28"	D52			15C-4419K	PolyMatrix C	150-9421K	BP-20
120-10939 ^(1, 2)	2 Piston Floating Mount	1.25 / 1.25"	1.04"	D52			15E-6102K	PolyMatrix E	150-9866K	BP-30
120-5289 ⁽³⁾	1 Piston Floating Mount	2.75"	1.25"	D52						
120-5861 ^(3, 4)	1 Piston Floating Mount	2.75"	1.00"	D52						
120-5288 ⁽³⁾	1 Piston Floating Mount	2.75"	0.81"	D52						
120-5344 ⁽³⁾	1 Piston Floating Mount	2.38"	1.25"	D52						
120-5343 ⁽³⁾	1 Piston Floating Mount	2.38"	0.81"	D52						

NOTES:

- (1) Available black powder coat, add -BK to end of part number.
- (2) Available red powder coat, add -RD to end of part number.
- (3) Slide pin kit p/n 230-0619 required for installation and must be ordered separately.
- (4) Includes slide pin vibration dampeners.

Calipers

Forged Billet GM D154 Metric Calipers

- Direct replacement for the 1978 and later intermediate GM OE cast iron calipers
- Lightweight, only 4.9 pounds
- Inlet fitting: M10 x 1.5 banjo
- Accepts OE D154 brake pads
- Forged billet aluminum bodies with computer FEA designed reinforced bridges make this the strongest aluminum metric replacement caliper available
- Stainless steel pistons and high temperature "seal-in-bore" design run cooler and eliminate all problems associated with external dust boots
- Inlet port accepts OE M10 x 1.5 banjo bolt brake line fitting
- Available for .81" or 1.04" rotor widths in gloss black, red, or fully polished
- Applicable part numbers are listed below in black

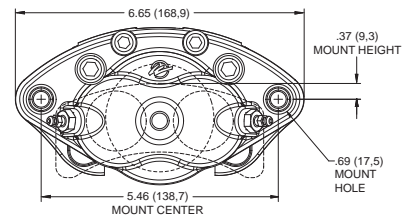

Aluminum GM Metric Racing Calipers

- Direct replacement for the 1978 and later intermediate GM OE cast iron calipers
- Clear anodized, lightweight cast aluminum bodies starting at only 2.92 pounds
- Inlet fitting: 1/8-27 NPT
- Exclusive triple bridge design provides added resistance against deflection under hard braking
- Stainless steel pistons and high temperature "seal-in-bore" design run cooler and eliminate all problems associated with external dust boots seals
- Slide pin kit required, order part number 230-0619, 4 pack
- Applicable part numbers are listed below in red

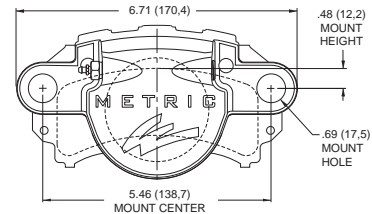

Cast Iron GM Metric Calipers

- Direct replacement for the 1978 and later intermediate GM OE cast iron calipers
- Optional 2.00" or 2.75" piston sizes assist with bias tuning and overall system capacity when cast iron calipers are required
- Inlet fitting: M10 x 1.5 banjo
- Stainless steel pistons and high temperature "seal-in-bore" design run cooler and eliminate all problems associated with external dust boots seals
- Slide pin kit required, order part number 230-0619, 4 pack
- Applicable part numbers are listed below in blue

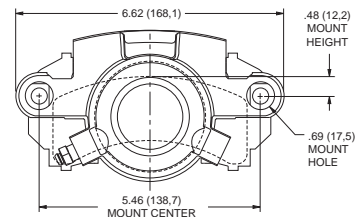

Caliper Ordering Information

PART NUMBER	DESCRIPTION	BORE SIZE	DISC WIDTH	PAD PLATE	PAD PLATE D154 PHYSICAL CHARACTERISTICS																						
					INNER PAD ABOVE, OUTER BELOW	INNER PAD ABOVE, OUTER BELOW	PAD P/N	PAD MAT'L																			
120-11870 ^(3, 4)	1 Piston Floating Mount	2.50"	1.04"	D154			<table border="1"> <thead> <tr> <th>PAD P/N</th> <th>PAD MAT'L</th> <th>PAD P/N</th> <th>PAD MAT'L</th> </tr> </thead> <tbody> <tr> <td>15A-6219K</td> <td>PolyMatrix A</td> <td>15Q-6831K</td> <td>PolyMatrix Q</td> </tr> <tr> <td>15B-3998K</td> <td>PolyMatrix B</td> <td>15O-8936K</td> <td>BP-10</td> </tr> <tr> <td>15C-4420L</td> <td>PolyMatrix C</td> <td>15O-9422K</td> <td>BP-20</td> </tr> <tr> <td>15E-6103K</td> <td>PolyMatrix E</td> <td>15O-12250K</td> <td>BP-40</td> </tr> </tbody> </table>	PAD P/N	PAD MAT'L	PAD P/N	PAD MAT'L	15A-6219K	PolyMatrix A	15Q-6831K	PolyMatrix Q	15B-3998K	PolyMatrix B	15O-8936K	BP-10	15C-4420L	PolyMatrix C	15O-9422K	BP-20	15E-6103K	PolyMatrix E	15O-12250K	BP-40
PAD P/N	PAD MAT'L	PAD P/N	PAD MAT'L																								
15A-6219K	PolyMatrix A	15Q-6831K	PolyMatrix Q																								
15B-3998K	PolyMatrix B	15O-8936K	BP-10																								
15C-4420L	PolyMatrix C	15O-9422K	BP-20																								
15E-6103K	PolyMatrix E	15O-12250K	BP-40																								
120-11870-P	1 Piston Floating Mount - Polished	2.50"	1.04"	D154																							
120-11871 ^(3, 4)	1 Piston Floating Mount	2.50"	0.81"	D154																							
120-11872 ^(3, 4)	2 Piston Floating Mount	1.62 / 1.62"	1.04"	D154																							
120-11873 ^(3, 4)	2 Piston Floating Mount	1.62 / 1.62"	0.81"	D154																							
120-11874 ^(3, 4)	2 Piston Floating Mount	1.12 / 1.12"	1.04"	D154																							
120-11874-P	2 Piston Floating Mount - Polished	1.12 / 1.12"	1.04"	D154																							
120-11875 ^(3, 4)	2 Piston Floating Mount	1.12 / 1.12"	0.81"	D154																							
120-11875-P	2 Piston Floating Mount - Polished	1.12 / 1.12"	0.81"	D154																							
120-6427 ⁽¹⁾	1 Piston Floating Mount	2.38"	1.25"	D154																							
120-7197 ^(1, 2)	1 Piston Floating Mount	2.38"	1.00"	D154																							
120-6426 ⁽¹⁾	1 Piston Floating Mount	2.38"	0.81"	D154																							
120-8924 ⁽¹⁾	1 Piston Floating Mount	2.75"	1.00"	D154																							
120-8926 ^(1, 2)	1 Piston Floating Mount	2.75"	1.00"	D154																							
120-9333 ⁽¹⁾	1 Piston Floating Mount	2.00"	1.00"	D154																							

NOTES:

- (1) Slide pin kit p/n 230-0619 required for installation and must be ordered separately. • (2) Includes slide pin vibration dampeners.
 (3) Available black powder coat, add -BK to end of part number. • (4) Available red powder coat, add -RD to end of part number.

Calipers

DynaPro Forged Billet Radial Mount Calipers

- Four corner bleed screws allow the caliper to be mounted in any front, rear, right, or left position, and only weighs 4.10 pounds
- Fits rotors from 10.00" to 13.00" in diameter, and widths from .38" to 1.25"
- Utilizes a 3.00 cubic inch type 7816 pad available in many Wilwood compounds
- Black anodized, other Wilwood colors available

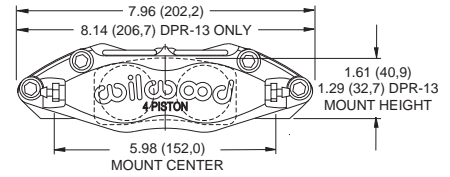

Caliper Ordering Information

PART NUMBER	DESCRIPTION	BORE SIZE	DISC WIDTH	PAD PLATE	PAD PLATE 7816 PHYSICAL CHARACTERISTICS																																
With Dust Boots for Rotors up to 12.19"																																					
120-7381	4 Piston Radial Mount	1.75 / 1.75"	1.00"	7816	<table border="1"> <thead> <tr> <th>PAD P/N</th> <th>PAD MAT'L</th> <th>PAD P/N</th> <th>PAD MAT'L</th> </tr> </thead> <tbody> <tr> <td>15A-7263K</td> <td>PolyMatrix A</td> <td>150-8946K</td> <td>BP-10</td> </tr> <tr> <td>15A-11932K</td> <td>PolyMatrix A (3)</td> <td>150-9419K</td> <td>BP-20</td> </tr> <tr> <td>15B-7264K</td> <td>PolyMatrix B</td> <td>150-9865K</td> <td>BP-30</td> </tr> <tr> <td>15B-11933K</td> <td>PolyMatrix B (3)</td> <td>150-12248K</td> <td>BP-40</td> </tr> <tr> <td>15E-7266K</td> <td>PolyMatrix E</td> <td>150-9753K</td> <td>CM</td> </tr> <tr> <td>15H-10645K</td> <td>PolyMatrix H</td> <td>150-10290K</td> <td>CM (3)</td> </tr> <tr> <td>15Q-7268K</td> <td>PolyMatrix Q</td> <td></td> <td></td> </tr> </tbody> </table>	PAD P/N	PAD MAT'L	PAD P/N	PAD MAT'L	15A-7263K	PolyMatrix A	150-8946K	BP-10	15A-11932K	PolyMatrix A (3)	150-9419K	BP-20	15B-7264K	PolyMatrix B	150-9865K	BP-30	15B-11933K	PolyMatrix B (3)	150-12248K	BP-40	15E-7266K	PolyMatrix E	150-9753K	CM	15H-10645K	PolyMatrix H	150-10290K	CM (3)	15Q-7268K	PolyMatrix Q		
PAD P/N	PAD MAT'L	PAD P/N	PAD MAT'L																																		
15A-7263K	PolyMatrix A	150-8946K	BP-10																																		
15A-11932K	PolyMatrix A (3)	150-9419K	BP-20																																		
15B-7264K	PolyMatrix B	150-9865K	BP-30																																		
15B-11933K	PolyMatrix B (3)	150-12248K	BP-40																																		
15E-7266K	PolyMatrix E	150-9753K	CM																																		
15H-10645K	PolyMatrix H	150-10290K	CM (3)																																		
15Q-7268K	PolyMatrix Q																																				
120-7380	4 Piston Radial Mount	1.75 / 1.75"	0.81"	7816																																	
120-7726	4 Piston Radial Mount	1.75 / 1.75"	0.50"	7816																																	
120-7379	4 Piston Radial Mount	1.62 / 1.62"	1.00"	7816																																	
120-7378 ⁽¹⁾	4 Piston Radial Mount	1.62 / 1.62"	0.81"	7816																																	
120-7328	4 Piston Radial Mount	1.50 / 1.50"	1.00"	7816																																	
120-7327 ⁽¹⁾	4 Piston Radial Mount	1.50 / 1.50"	0.81"	7816																																	
120-7722	4 Piston Radial Mount	1.50 / 1.50"	0.50"	7816																																	
120-7377	4 Piston Radial Mount	1.38 / 1.38"	1.00"	7816																																	
120-7376	4 Piston Radial Mount	1.38 / 1.38"	0.81"	7816																																	
120-7724	4 Piston Radial Mount	1.38 / 1.38"	0.50"	7816																																	
120-7375	4 Piston Radial Mount	1.25 / 1.25"	1.00"	7816																																	
120-7374 ⁽¹⁾	4 Piston Radial Mount	1.25 / 1.25"	0.81"	7816																																	
Without Dust Boots for Rotors up to 12.19"																																					
120-8545	4 Piston Radial Mount	1.75 / 1.75"	1.00"	7816																																	
120-8544-SI	4 Piston Radial Mount - Side Inlet	1.75 / 1.75"	0.81"	7816																																	
120-8543-SI	4 Piston Radial Mount - Side Inlet	1.75 / 1.75"	0.50"	7816																																	
120-8542	4 Piston Radial Mount	1.62 / 1.62"	1.00"	7816																																	
120-8541	4 Piston Radial Mount	1.62 / 1.62"	0.81"	7816																																	
120-8539	4 Piston Radial Mount	1.38 / 1.38"	1.00"	7816																																	
120-8538	4 Piston Radial Mount	1.38 / 1.38"	0.81"	7816																																	
120-8536	4 Piston Radial Mount	1.25 / 1.25"	1.00"	7816																																	
120-8534	4 Piston Radial Mount	1.25 / 1.25"	0.50"	7816																																	
DPR 13 W/Dust Boots for Rotors up to 13.00"																																					
120-9758	4 Piston Radial Mount	1.75 / 1.75"	1.10"	7816																																	
120-9749	4 Piston Radial Mount	1.25 / 1.25"	1.10"	7816																																	
120-9750 ⁽¹⁾	4 Piston Radial Mount	1.00 / 1.00"	1.10"	7816																																	
250-9595	Radial Mount Bracket - 3.50" Mount Center, 10.50" Rotor Diameter																																				

NOTES:

(1) Available red, add -RD to end of part number • (2) -SI calipers use bridge bolt assemblies instead of pad retainer clips • (3) This pad is modified for -SI calipers

Billet Narrow Dynalite Radial Mount Calipers

- Compact & lightweight starting at 2.70 pounds
- Radial mount kits are used to install this radial caliper in place of a tab mount caliper
- Internal fluid passage eliminates external crossover tubes
- SRS bridge plates eliminate pad gouging
- Uses type 7216 pads
- Black anodized to provide a long lasting finish

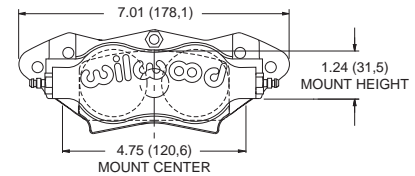

Caliper Ordering Information

PART NUMBER	DESCRIPTION	BORE SIZE	DISC WIDTH	PAD PLATE	PAD PLATE 7816 PHYSICAL CHARACTERISTICS																				
120-6454	4 Piston Radial Mount	1.75 / 1.75"	0.81"	7216	<table border="1"> <thead> <tr> <th>PAD P/N</th> <th>PAD MAT'L</th> <th>PAD P/N</th> <th>PAD MAT'L</th> </tr> </thead> <tbody> <tr> <td>15A-7263K</td> <td>PolyMatrix A</td> <td>15Q-7268K</td> <td>PolyMatrix Q</td> </tr> <tr> <td>15B-7264K</td> <td>PolyMatrix B</td> <td>150-9865K</td> <td>BP-30</td> </tr> <tr> <td>15E-7266K</td> <td>PolyMatrix E</td> <td>150-12248K</td> <td>BP-40</td> </tr> <tr> <td>15H-10645K</td> <td>PolyMatrix H</td> <td>150-10290K</td> <td>CM</td> </tr> </tbody> </table>	PAD P/N	PAD MAT'L	PAD P/N	PAD MAT'L	15A-7263K	PolyMatrix A	15Q-7268K	PolyMatrix Q	15B-7264K	PolyMatrix B	150-9865K	BP-30	15E-7266K	PolyMatrix E	150-12248K	BP-40	15H-10645K	PolyMatrix H	150-10290K	CM
PAD P/N	PAD MAT'L	PAD P/N	PAD MAT'L																						
15A-7263K	PolyMatrix A	15Q-7268K	PolyMatrix Q																						
15B-7264K	PolyMatrix B	150-9865K	BP-30																						
15E-7266K	PolyMatrix E	150-12248K	BP-40																						
15H-10645K	PolyMatrix H	150-10290K	CM																						
120-6454-SI	4 Piston Radial Mount - Side Inlet	1.75 / 1.75"	0.81"	7216																					
120-6453	4 Piston Radial Mount	1.75 / 1.75"	0.38"	7216																					
120-6453-SI	4 Piston Radial Mount - Side Inlet	1.75 / 1.75"	0.38"	7216																					
250-6452	Radial Mount Bracket Kit - 3.50" Mount Center, 12.19" Rotor Dia.																								

Calipers

Billet Narrow Mount DynaPro Calipers

- Four corner bleed screws allow the caliper to be mounted in any front, rear, right, or left position, and only weighs 4.10 pounds
- Stainless steel pistons to resist corrosion and retard the transfer of heat
- Black anodized to provide a durable long lasting finish

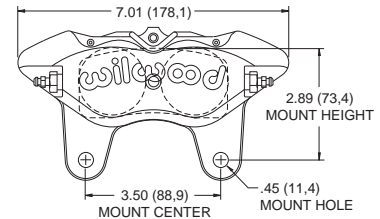

Caliper Ordering Information

PART NUMBER	DESCRIPTION	BORE SIZE	DISC WIDTH	PAD PLATE	PAD PLATE 7816	
					PHYSICAL CHARACTERISTICS	
120-9737	4 Piston Lug Mount	1.75 / 1.75"	1.25"			
120-9736	4 Piston Lug Mount	1.75 / 1.75"	0.81"	7816		
120-9736-SI	4 Piston Lug Mount - Side Inlet	1.75 / 1.75"	0.81"	7816		
120-9735	4 Piston Lug Mount	1.75 / 1.75"	0.50"	7816		
120-9734	4 Piston Lug Mount	1.75 / 1.75"	0.38"	7816		
120-9734-SI	4 Piston Lug Mount - Side Inlet	1.75 / 1.75"	0.38"	7816		
120-9733	4 Piston Lug Mount	1.62 / 1.62"	1.25"	7816		
120-9732	4 Piston Lug Mount	1.62 / 1.62"	0.81"	7816		
120-9731	4 Piston Lug Mount	1.62 / 1.62"	0.50"	7816		
120-9730	4 Piston Lug Mount	1.62 / 1.62"	0.38"	7816		
120-9729	4 Piston Lug Mount	1.38 / 1.38"	1.25"	7816		
120-9728	4 Piston Lug Mount	1.38 / 1.38"	0.81"	7816		
120-9727	4 Piston Lug Mount	1.38 / 1.38"	0.50"	7816		
120-9726	4 Piston Lug Mount	1.38 / 1.38"	0.38"	7816		
120-10522	4 Piston Lug Mount	1.25 / 1.25"	1.25"	7816		
120-10521	4 Piston Lug Mount	1.25 / 1.25"	0.81"	7816		
120-9725	4 Piston Lug Mount	1.12 / 1.12"	1.25"	7816		
120-9724	4 Piston Lug Mount	1.12 / 1.12"	0.81"	7816		
120-9722	4 Piston Lug Mount	1.12 / 1.12"	0.38"	7816		
120-9722-P	4 Piston Lug Mount - Polished	1.12 / 1.12"	0.38"	7816		
120-9721	4 Piston Lug Mount	1.00 / 1.00"	1.25"	7816		
120-9720	4 Piston Lug Mount	1.00 / 1.00"	0.81"	7816		
120-9718	4 Piston Lug Mount	1.00 / 1.00"	0.38"	7816		

PAD P/N	PAD MAT'L	PAD P/N	PAD MAT'L
15A-7263K	PolyMatrix A	150-8946K	BP-10
15A-11932K	PolyMatrix A ⁽¹⁾	150-9419K	BP-20
15B-7264K	PolyMatrix B	150-9865K	BP-30
15B-11933K	PolyMatrix B ⁽¹⁾	150-12248K	BP-40
15E-7266K	PolyMatrix E	150-9753K	CM
15H-10645K	PolyMatrix H	150-10290K	CM ⁽¹⁾
15Q-7268K	PolyMatrix Q		

NOTES:

(1) These pads have been modified for the pad retainer screws used in all "-SI" model calipers

Billet Narrow Radial Mount DynaPro Calipers

- Designed specifically to fit low profile, low clearance for late model drag applications
- Weights starting at just 4.10 pounds
- Designed to fit rotors up to 12.19" diameter
- Caliper utilizes stainless steel pistons to provide protection against corrosion and heat transfer from the pads
- Black anodized to provide a long lasting finish

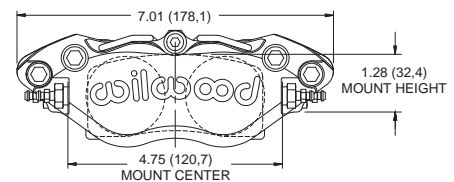

Caliper Ordering Information

PART NUMBER	DESCRIPTION	BORE SIZE	DISC WIDTH	PAD PLATE	PAD PLATE 7812	
					PHYSICAL CHARACTERISTICS	
120-10000	4 Piston Radial Mount	1.75 / 1.75"	0.81"	7812		
120-9993	4 Piston Radial Mount	1.75 / 1.75"	0.38"	7812		

PAD P/N	PAD MAT'L	PAD P/N	PAD MAT'L
15A-9835K	PolyMatrix A	150-9136K	BP-10
15B-9836K	PolyMatrix B	150-9418K	BP-20
15E-9837K	PolyMatrix E	150-11735K	BP-30
15H-10644K	PolyMatrix H	150-12247K	BP-40
15Q-10385K	PolyMatrix Q	150-10020K	CM

Calipers

Billet DynaPro 6 Lug Mount Calipers

- Complete bolt-on interchange ability to the four piston 5.25" lug mount DynaPro and Dyalite caliper series
- Performance advantages of a larger pad and six piston differential bore configuration
- Exclusive Quick-E clips for simplified pad service without caliper removal
- Weights starting at just 7.70 pounds
- Black powder coat, other Wilwood colors available

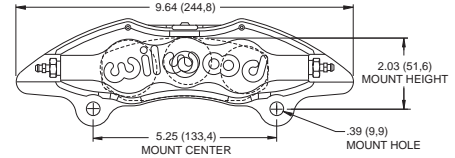

Caliper Ordering Information

PART NUMBER	DESCRIPTION	BORE SIZE	DISC WIDTH	PAD PLATE	PAD PLATE 6712 PHYSICAL CHARACTERISTICS																				
120-10120	6 Piston Lug Mount - RH	1.62 / 1.38 / 1.38"	1.10"	6712	<table border="1"> <thead> <tr> <th>PAD P/N</th> <th>PAD MAT'L</th> <th>PAD P/N</th> <th>PAD MAT'L</th> </tr> </thead> <tbody> <tr> <td>15A-10724K</td> <td>PolyMatrix A</td> <td>150-10006K</td> <td>BP-10</td> </tr> <tr> <td>15B-10725K</td> <td>PolyMatrix B</td> <td>150-10007K</td> <td>BP-20</td> </tr> <tr> <td>15E-12605K</td> <td>PolyMatrix E</td> <td>150-12760K</td> <td>BP-40</td> </tr> <tr> <td>15H-10726K</td> <td>PolyMatrix H</td> <td></td> <td></td> </tr> </tbody> </table>	PAD P/N	PAD MAT'L	PAD P/N	PAD MAT'L	15A-10724K	PolyMatrix A	150-10006K	BP-10	15B-10725K	PolyMatrix B	150-10007K	BP-20	15E-12605K	PolyMatrix E	150-12760K	BP-40	15H-10726K	PolyMatrix H		
PAD P/N	PAD MAT'L	PAD P/N	PAD MAT'L																						
15A-10724K	PolyMatrix A	150-10006K	BP-10																						
15B-10725K	PolyMatrix B	150-10007K	BP-20																						
15E-12605K	PolyMatrix E	150-12760K	BP-40																						
15H-10726K	PolyMatrix H																								
120-10121	6 Piston Lug Mount - LH	1.62 / 1.38 / 1.38"	1.10"	6712																					
120-10122 ⁽¹⁾	6 Piston Lug Mount - RH	1.62 / 1.38 / 1.38"	0.81"	6712																					
120-10123 ⁽¹⁾	6 Piston Lug Mount - LH	1.62 / 1.38 / 1.38"	0.81"	6712																					
120-10124	6 Piston Lug Mount - RH	1.62 / 1.38 / 1.38"	0.38"	6712																					
120-10125	6 Piston Lug Mount - LH	1.62 / 1.38 / 1.38"	0.38"	6712																					
120-10126	6 Piston Lug Mount - RH	1.62 / 1.12 / 1.12"	1.10"	6712																					
120-10127	6 Piston Lug Mount - LH	1.62 / 1.12 / 1.12"	1.10"	6712																					
120-10128 ⁽¹⁾	6 Piston Lug Mount - RH	1.62 / 1.12 / 1.12"	0.81"	6712																					
120-10128-P	6 Piston Lug Mount - RH - Polished	1.62 / 1.12 / 1.12"	0.81"	6712																					
120-10129 ⁽¹⁾	6 Piston Lug Mount - LH	1.62 / 1.12 / 1.12"	0.81"	6712																					
120-10129-P	6 Piston Lug Mount - LH - Polished	1.62 / 1.12 / 1.12"	0.81"	6712																					
120-10132	6 Piston Lug Mount - RH	1.38 / 1.00 / 1.00"	1.10"	6712																					
120-10133	6 Piston Lug Mount - LH	1.38 / 1.00 / 1.00"	1.10"	6712																					
120-10134 ⁽¹⁾	6 Piston Lug Mount - RH	1.38 / 1.00 / 1.00"	0.81"	6712																					
120-10135 ⁽¹⁾	6 Piston Lug Mount - LH	1.38 / 1.00 / 1.00"	0.81"	6712																					
120-10136	6 Piston Lug Mount - RH	1.38 / 1.00 / 1.00"	0.38"	6712																					
120-10137	6 Piston Lug Mount - LH	1.38 / 1.00 / 1.00"	0.38"	6712																					

NOTES:

(1) Available red, add -RD to end of part number.

Billet DynaPro Lug Mount Calipers

- Lightweight, only 3.8 pounds
- A sleek profile with superior strength provides performance and looks for competition or show
- Caliper utilizes stainless steel pistons to provide protection against corrosion and heat transfer from the pads
- Black anodized, other Wilwood colors available

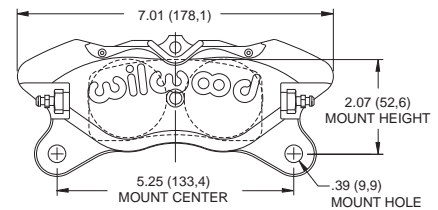

Caliper Ordering Information

PART NUMBER	DESCRIPTION	BORE SIZE	DISC WIDTH	PAD PLATE	PAD PLATE 7812 PHYSICAL CHARACTERISTICS																								
120-9691	4 Piston Lug Mount	1.75 / 1.75"	1.25"	7812	<table border="1"> <thead> <tr> <th>PAD P/N</th> <th>PAD MAT'L</th> <th>PAD P/N</th> <th>PAD MAT'L</th> </tr> </thead> <tbody> <tr> <td>15A-9835K</td> <td>PolyMatrix A</td> <td>150-9136K</td> <td>BP-10</td> </tr> <tr> <td>15B-9836K</td> <td>PolyMatrix B</td> <td>150-9418K</td> <td>BP-20</td> </tr> <tr> <td>15E-9837K</td> <td>PolyMatrix E</td> <td>150-11735K</td> <td>BP-30</td> </tr> <tr> <td>15H-10644K</td> <td>PolyMatrix H</td> <td>150-12247K</td> <td>BP-40</td> </tr> <tr> <td>15Q-10385K</td> <td>PolyMatrix Q</td> <td>150-10020K</td> <td>CM</td> </tr> </tbody> </table>	PAD P/N	PAD MAT'L	PAD P/N	PAD MAT'L	15A-9835K	PolyMatrix A	150-9136K	BP-10	15B-9836K	PolyMatrix B	150-9418K	BP-20	15E-9837K	PolyMatrix E	150-11735K	BP-30	15H-10644K	PolyMatrix H	150-12247K	BP-40	15Q-10385K	PolyMatrix Q	150-10020K	CM
PAD P/N	PAD MAT'L	PAD P/N	PAD MAT'L																										
15A-9835K	PolyMatrix A	150-9136K	BP-10																										
15B-9836K	PolyMatrix B	150-9418K	BP-20																										
15E-9837K	PolyMatrix E	150-11735K	BP-30																										
15H-10644K	PolyMatrix H	150-12247K	BP-40																										
15Q-10385K	PolyMatrix Q	150-10020K	CM																										
120-9692	4 Piston Lug Mount	1.75 / 1.75"	1.00"	7812																									
120-9693 ⁽¹⁾	4 Piston Lug Mount	1.75 / 1.75"	0.81"	7812																									
120-9693-SI	4 Piston Lug Mount - Side Inlet	1.75 / 1.75"	0.81"	7812																									
120-9694	4 Piston Lug Mount	1.75 / 1.75"	0.50"	7812																									
120-9695	4 Piston Lug Mount	1.75 / 1.75"	0.38"	7812																									
120-9695-SI	4 Piston Lug Mount - Side Inlet	1.75 / 1.75"	0.38"	7812																									
120-9701	4 Piston Lug Mount	1.38 / 1.38"	1.25"	7812																									
120-9702	4 Piston Lug Mount	1.38 / 1.38"	1.00"	7812																									
120-9703 ⁽¹⁾	4 Piston Lug Mount	1.38 / 1.38"	0.81"	7812																									
120-9704	4 Piston Lug Mount	1.38 / 1.38"	0.50"	7812																									
120-9705	4 Piston Lug Mount	1.38 / 1.38"	0.38"	7812																									
120-9706 ⁽¹⁾	4 Piston Lug Mount	1.00 / 1.00"	0.81"	7812																									

NOTES:

- (1) Available red, add -RD to end of part number.
- (2) -SI calipers use bridge bolt assemblies instead of pad retainer clips

Calipers

Billet DynaPro Lug Mount Calipers w/Dust Boots

- Developed for applications that require or prefer a dust-booted piston
- The dust boots work in conjunction with high temperature seals to provide ultimate reliability
- Features Quick-E-Clip pad retainers that allow for fast pad service without caliper removal
- Optional bridge bolt kit for high load applications
- Lightweight at only 3.8 pounds

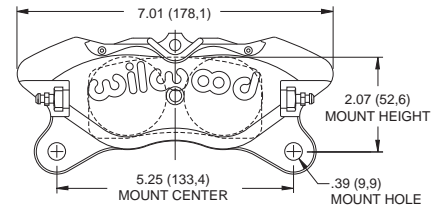

Caliper Ordering Information

PART NUMBER	DESCRIPTION	BORE SIZE	DISC WIDTH	PAD PLATE	PAD PLATE 7812	
					PHYSICAL CHARACTERISTICS	
120-11482 ⁽¹⁾	4 Piston Lug Mount	1.75 / 1.75"	0.81"	7812		
120-11482-P	4 Piston Lug Mount - Polished	1.75 / 1.75"	0.81"	7812		
120-11481 ⁽¹⁾	4 Piston Lug Mount	1.38 / 1.38"	0.81"	7812		
120-11481-P	4 Piston Lug Mount - Polished	1.38 / 1.38"	0.81"	7812		

<u>PAD P/N</u>	<u>PAD MAT'L</u>	<u>PAD P/N</u>	<u>PAD MAT'L</u>
15A-9835K	PolyMatrix A	150-9136K	BP-10
15B-9836K	PolyMatrix B	150-9418K	BP-20
15E-9837K	PolyMatrix E	150-11735K	BP-30
15H-10644K	PolyMatrix H	150-12247K	BP-40
15Q-10385K	PolyMatrix Q	150-10020K	CM

NOTES:

(1) Available red, add -RD to end of part number.

Forged DynaPro Low-Profile Lug Mount Calipers

- Developed for applications that require a low profile, limited swept area pad
- Calipers utilize stainless steel pistons for their low heat transfer properties and high resistance to corrosion
- Uses 4812 pads specifically designed for rotor contact surfaces as small as 1.30" high
- Only weighs 3.6 pounds
- Black anodized, other Wilwood colors available

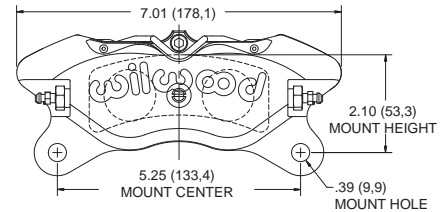

Caliper Ordering Information

PART NUMBER	DESCRIPTION	BORE SIZE	DISC WIDTH	PAD PLATE	PAD PLATE 4812	
					PHYSICAL CHARACTERISTICS	
120-12160 ^(1, 2)	4 Piston Lug Mount - Low Profile	1.12 / 1.12"	0.81"	4812		
120-12160-P	4 Piston Lug Mount - Low Profile Polished	1.12 / 1.12"	0.81"	4812		

<u>PAD P/N</u>	<u>PAD MAT'L</u>
150-11363K	BP-10

NOTES:

(1) Available red powder coat, add -RD to end of part number.
 (2) Available black powder coat, add -BK to end of part number.

Calipers

Forged Narrow Dynalite Lug Mount Calipers

- Direct replacement for all narrow mount Dynalite calipers with 3.50" centered mounting tabs
- Four corner bleed screws allows one caliper to be mounted in any front, rear, right or left position.
- SRS bridge plates eliminate bridge wear caused by pad gouging and extend the service life of the caliper body
- Lightweight at only 3.8 pounds
- Calipers are finished in black anodize for a long lasting durable finish

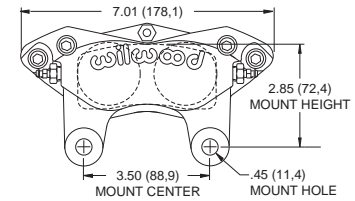

Caliper Ordering Information

PART NUMBER	DESCRIPTION	BORE SIZE	DISC WIDTH	PAD PLATE	PAD PLATE 7816 PHYSICAL CHARACTERISTICS				
					PAD P/N	PAD MAT'L	PAD P/N	PAD MAT'L	
120-11573	4 Piston Lug Mount	1.75 / 1.75"	1.25"	7816		15A-7263K	PolyMatrix A	150-8946K	BP-10
120-11572	4 Piston Lug Mount	1.75 / 1.75"	0.81"	7816		15B-7264K	PolyMatrix B	150-9419K	BP-20
120-11572-SI	4 Piston Lug Mount - Side Inlet	1.75 / 1.75"	0.81"	7816		15E-7266K	PolyMatrix E	150-9865K	BP-30
120-11571	4 Piston Lug Mount	1.75 / 1.75"	0.38"	7816		15H-10645K	PolyMatrix H	150-12248K	BP-40
120-11571-SI	4 Piston Lug Mount - Side Inlet	1.75 / 1.75"	0.38"	7816		15Q-7268K	PolyMatrix Q	150-9753K	CM
120-11576	4 Piston Lug Mount	1.38 / 1.38"	1.25"	7816					
120-11575	4 Piston Lug Mount	1.38 / 1.38"	0.81"	7816					
120-11574	4 Piston Lug Mount	1.38 / 1.38"	0.38"	7816					
120-11579	4 Piston Lug Mount	1.12 / 1.12"	1.25"	7816					
120-11578	4 Piston Lug Mount	1.12 / 1.12"	0.81"	7816					
120-11578-P	4 Piston Lug Mount - Polished	1.12 / 1.12"	0.81"	7816					
120-11577	4 Piston Lug Mount	1.12 / 1.12"	0.38"	7816					
120-11577-P	4 Piston Lug Mount - Polished	1.12 / 1.12"	0.38"	7816					

Forged Billet Dynalite Calipers

- Four corner bleed screws allow the caliper to be mounted in any front, rear, right, or left position, at only 3.40 pounds
- Finished in black anodize for a long lasting durable finish
- Internal fluid passages - no external tubes
- Utilizes a 2.10 cubic inch type 7112 pad available in numerous Wilwood compounds

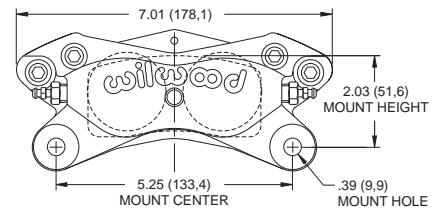

Caliper Ordering Information

PART NUMBER	DESCRIPTION	BORE SIZE	DISC WIDTH	PAD PLATE	PAD PLATE 7112 PHYSICAL CHARACTERISTICS				
					PAD P/N	PAD MAT'L	PAD P/N	PAD MAT'L	
120-6814	4 Piston Lug Mount	1.75 / 1.75"	1.25"	7112		15A-5734K	PolyMatrix A	150-8850K	BP-10
120-6815	4 Piston Lug Mount	1.75 / 1.75"	1.00"	7112		15B-3991K	PolyMatrix B	150-9413K	BP-20
120-6816 ^(1,2)	4 Piston Lug Mount	1.75 / 1.75"	0.81"	7112		15C-4415K	PolyMatrix C	150-9863K	BP-30
120-6817	4 Piston Lug Mount	1.75 / 1.75"	0.50"	7112		15E-6096K	PolyMatrix E	150-12243K	BP-40
120-6818	4 Piston Lug Mount	1.75 / 1.75"	0.38"	7112		15H-8291K	PolyMatrix H	150-8450K	CM
120-6810	4 Piston Lug Mount	1.62 / 1.62"	1.00"	7112					
120-6795-P	4 Piston Lug Mount - Polished	1.62 / 1.62"	1.00"	7112					
120-6811 ⁽¹⁾	4 Piston Lug Mount	1.62 / 1.62"	0.81"	7112					
120-6796-P	4 Piston Lug Mount - Polished	1.62 / 1.62"	0.81"	7112					
120-6813	4 Piston Lug Mount	1.62 / 1.62"	0.38"	7112					
120-6798-P	4 Piston Lug Mount - Polished	1.62 / 1.62"	0.38"	7112					
120-6804	4 Piston Lug Mount	1.38 / 1.38"	1.25"	7112					
120-6805	4 Piston Lug Mount	1.38 / 1.38"	1.00"	7112					
120-6806 ^(1,2)	4 Piston Lug Mount	1.38 / 1.38"	0.81"	7112					
120-6791-P	4 Piston Lug Mount - Polished	1.38 / 1.38"	0.81"	7112					
120-6807	4 Piston Lug Mount	1.38 / 1.38"	0.50"	7112					
120-6792-P	4 Piston Lug Mount	1.38 / 1.38"	0.50"	7112					
120-6808	4 Piston Lug Mount	1.38 / 1.38"	0.38"	7112					

NOTES:

(1) Available red, add -RD to end of part number • (2) Available in black powdercoat, add -BK to end of part number

Calipers

Billet Powerlite Calipers

- Compact & lightweight starting at 2.26 pounds
- Radial mount kits are used to install this radial caliper in place of a tab mount caliper
- Internal fluid passage eliminates external crossover tubes
- SRS bridge plates eliminate pad gouging
- Uses type 7912 pads
- Black anodized to provide a long lasting durable finish

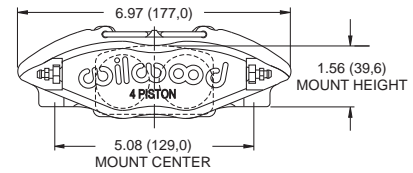

Caliper Ordering Information

PART NUMBER	DESCRIPTION	BORE SIZE	DISC WIDTH	PAD PLATE	PAD PLATE 7912 PHYSICAL CHARACTERISTICS																							
					3.13 (79.5)		.49 (12.4)																					
120-8729	4 Piston Radial Mount	1.38 / 1.38"	0.86"	7912	<table border="1"> <thead> <tr> <th>PAD P/N</th> <th>PAD MAT'L</th> <th>PAD P/N</th> <th>PAD MAT'L</th> </tr> </thead> <tbody> <tr> <td>15A-8809K</td> <td>PolyMatrix A</td> <td>15Q-8812K</td> <td>PolyMatrix Q</td> </tr> <tr> <td>15B-8949K</td> <td>PolyMatrix B</td> <td>15O-8813K</td> <td>BP-10</td> </tr> <tr> <td>15E-8810K</td> <td>PolyMatrix E</td> <td>15O-9420K</td> <td>BP-20</td> </tr> <tr> <td>15H-8811K</td> <td>PolyMatrix H</td> <td>15O-12842K</td> <td>BP-40</td> </tr> </tbody> </table>				PAD P/N	PAD MAT'L	PAD P/N	PAD MAT'L	15A-8809K	PolyMatrix A	15Q-8812K	PolyMatrix Q	15B-8949K	PolyMatrix B	15O-8813K	BP-10	15E-8810K	PolyMatrix E	15O-9420K	BP-20	15H-8811K	PolyMatrix H	15O-12842K	BP-40
PAD P/N	PAD MAT'L	PAD P/N	PAD MAT'L																									
15A-8809K	PolyMatrix A	15Q-8812K	PolyMatrix Q																									
15B-8949K	PolyMatrix B	15O-8813K	BP-10																									
15E-8810K	PolyMatrix E	15O-9420K	BP-20																									
15H-8811K	PolyMatrix H	15O-12842K	BP-40																									
120-8726 ⁽¹⁾	4 Piston Radial Mount	1.38 / 1.38"	0.50"	7912																								
120-8728	4 Piston Radial Mount	1.25 / 1.25"	0.86"	7912																								
120-8725	4 Piston Radial Mount	1.25 / 1.25"	0.50"	7912																								
120-8727	4 Piston Radial Mount	1.00 / 1.00"	0.86"	7912																								
120-8724	4 Piston Radial Mount	1.00 / 1.00"	0.50"	7912																								

NOTES:

(1) Available red, add -RD to end of part number.

Combination Parking Brake Calipers

- Uses hydraulic pressure for stopping and a mechanical locking mechanism for a parking brake
- Single piston floating design that attaches to a fixed radial mount bracket
- Fits rotor diameters from 11.00" to 13.00" and either .81" or 1.00" width discs.
- Only weighs 6.10 pounds
- Available black or red powder coated

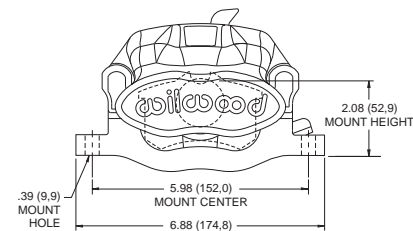

Caliper Ordering Information

PART NUMBER	DESCRIPTION	BORE SIZE	DISC WIDTH	PAD PLATE	PAD PLATE D340 PHYSICAL CHARACTERISTICS															
					3.43 (87.1)		.58 (14.7)													
120-10110-BK	1 Piston Radial Mount - LH	1.62"	1.00"	D340	<table border="1"> <thead> <tr> <th>PAD P/N</th> <th>PAD MAT'L</th> <th>PAD P/N</th> <th>PAD MAT'L</th> </tr> </thead> <tbody> <tr> <td>15Q-10254K</td> <td>PolyMatrix Q</td> <td>15O-10661K</td> <td>BP-20</td> </tr> <tr> <td>15O-9184K</td> <td>BP-10</td> <td></td> <td></td> </tr> </tbody> </table>				PAD P/N	PAD MAT'L	PAD P/N	PAD MAT'L	15Q-10254K	PolyMatrix Q	15O-10661K	BP-20	15O-9184K	BP-10		
PAD P/N	PAD MAT'L	PAD P/N	PAD MAT'L																	
15Q-10254K	PolyMatrix Q	15O-10661K	BP-20																	
15O-9184K	BP-10																			
120-10110-RD	1 Piston Radial Mount - LH	1.62"	1.00"	D340																
120-10111-BK	1 Piston Radial Mount - RH	1.62"	1.00"	D340																
120-10111-RD	1 Piston Radial Mount - RH	1.62"	1.00"	D340																
120-10112-BK	1 Piston Radial Mount - LH	1.62"	0.81"	D340																
120-10112-RD	1 Piston Radial Mount - LH	1.62"	0.81"	D340																
120-10113-BK	1 Piston Radial Mount - RH	1.62"	0.81"	D340																
120-10113-RD	1 Piston Radial Mount - RH	1.62"	0.81"	D340																
120-9808-BK	1 Piston Radial Mount - RH	1.34"	0.81"	D340																
120-9808-RD	1 Piston Radial Mount - RH	1.34"	0.81"	D340																
120-9809-BK	1 Piston Radial Mount - LH	1.34"	0.81"	D340																
120-9809-RD	1 Piston Radial Mount - LH	1.34"	0.81"	D340																

NOTES:

Caliper comes in black powder coat, -BK, or red powder coat, -RD.

Technical Tip

Caliper Rebuilding

If you race on a weekly basis you should disassemble your calipers mid season to inspect and clean pistons and replace any pistons that may be damaged or show signs of excessive wear. New seals should always be installed when servicing calipers. High temperature demands of short track asphalt racing may necessitate more frequent rebuilds to insure against on track braking issues. See our web site at www.wilwood.com for caliper specific replacement parts and check out our new assembly lube on page 67, developed specifically for caliper and master cylinder rebuilds and maintenance.

Calipers

DynaPro / Dynalite Single Calipers

- Comes in two bore sizes, 1.75" or 1.38" and two mounting options, 3.75" or 3.25"
- Weights starting at only 2.30 pounds
- Four corner bleed screws allow the caliper to be mounted in any front, rear, right, or left position
- Internal fluid passage eliminates external crossover tubes
- One piece stainless steel pistons resist corrosion and slow the heat transfer from the pads
- Black anodized for a long lasting durable finish



Dynalite Single Shown Inset

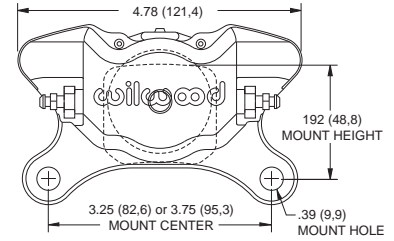

Caliper Ordering Information

PART NUMBER	DESCRIPTION	BORE SIZE	DISC WIDTH	PAD PLATE	PAD PLATE 6812 PHYSICAL CHARACTERISTICS			
					PAD P/N	PAD MAT'L	PAD P/N	PAD MAT'L
DynaPro Single								
120-9687	2 Piston - 3.25" Lug Mount	1.75"	0.38"	6812				
120-9687-P	2 Piston - 3.25" Lug Mount - Polished	1.75"	0.38"	6812				
120-10188	2 Piston - 3.25" Lug Mount - LW	1.75"	0.38"	6812				
120-9689-LP	2 Piston - 3.75" Lug Mount	1.75"	0.19"	6812				
120-9689-PLP	2 Piston - 3.75" Lug Mount - Polished	1.75"	0.19"	6812				
120-9688	2 Piston - 3.25" Lug Mount	1.38"	0.38"	6812				
120-9688-LP	2 Piston - 3.25" Lug Mount	1.38"	0.19"	6812				
120-9690	2 Piston - 3.75" Lug Mount	1.38"	0.38"	6812				
Dynalite Single								
120-4060	2 Piston - 3.75" Lug Mount	1.75"	0.38"	6812	15B-9819K	PolyMatrix B	150-9862K	BP-30
120-4062	2 Piston - 3.25" Lug Mount	1.75"	0.38"	6812	15E-9820K	PolyMatrix E	150-12242K	BP-40
					15Q-10144K	PolyMatrix Q	150-9756K	CM
					150-9764K	BP-10	150-9766K	Alum Rotor (purple pad)

GP 320 Calipers

- Lightweight at just 1.70 pounds
- Fits rotors from 9.00" to 11.50" in diameter, and widths from .19" to .81"
- Quick-Clip retention pin provides easy access for pad service without caliper removal
- Utilizes a 1.03 cubic inch type 6211 pad available in two Wilwood compounds
- Black anodized to provide a durable long lasting finish

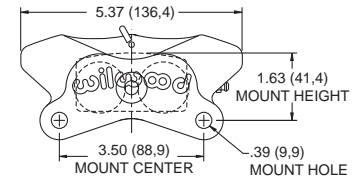

Caliper Ordering Information

PART NUMBER	DESCRIPTION	BORE SIZE	DISC WIDTH	PAD PLATE	PAD PLATE 6211 PHYSICAL CHARACTERISTICS			
					PAD P/N	PAD MAT'L	PAD P/N	PAD MAT'L
120-10714	4 Piston Lug Mount - R/H	1.25 / 1.25"	0.81"	6211				
120-10715	4 Piston Lug Mount - L/H	1.25 / 1.25"	0.81"	6211				
120-8524	4 Piston Lug Mount - R/H	1.25 / 1.25"	0.24"	6211				
120-8525	4 Piston Lug Mount - L/H	1.25 / 1.25"	0.24"	6211				
					150-10396K	CM	15H-8596K	PolyMatrix H

NOTES:

Right hand and left hand orientation are based on rear (trailing) mount standards for front mount applications, exchange the calipers right to left to maintain an upright bleed orientation.

Calipers

Dynalite Single Floater Calipers

- Designed for Open Wheel, Drag Race, Karting and Motorcycle applications
- Weighing just 1.60 pounds, caliper uses the same .49" thick Dynalite Single quick change pads
- Multiple 1/8-27 NPT inlet and bleed screw locations allow for versatile mounting positions
- Fits rotors from .25" to .38" wide and diameters from 6.00" to 13.00"
- Black anodized for a durable long lasting finish

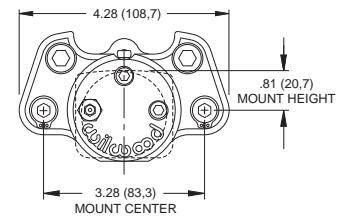

Caliper Ordering Information

PART NUMBER	DESCRIPTION	BORE SIZE	DISC WIDTH	PAD PLATE	PAD PLATE 6812 PHYSICAL CHARACTERISTICS			
					PAD P/N	PAD MAT'L	PAD P/N	PAD MAT'L
120-3277	1 Piston Floating Mount	1.75"	0.38"	6812				
120-2498	1 Piston Floating Mount	1.75"	0.25"	6812				
					15A-10142K	PolyMatrix A	150-9765K	BP-20
					15B-9819K	PolyMatrix B	150-9862K	BP-30
					15E-9820K	PolyMatrix E	150-12242K	BP-40
					15Q-10144K	PolyMatrix Q	150-9756K	CM
					150-9764K	BP-10	150-9766K	Alum Rotor

Billet Spot Calipers

- Designed for Open Wheel, Drag Race, Karting and Motorcycle applications
- Weighing just 1.20 pounds and holds a round .25" thick, .7 cubic inch brake pad
- Multiple 1/8-27 NPT inlet and bleed screw locations allow for versatile mounting positions
- Fits rotors from .25" to .38" wide and diameters from 6.00" to 13.00"
- Black anodized for a long lasting finish

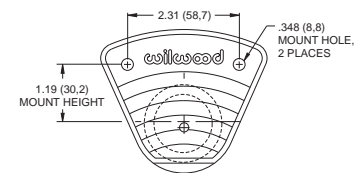

Caliper Ordering Information

PART NUMBER	DESCRIPTION	BORE SIZE	DISC WIDTH	PAD PLATE	PAD PLATE 4009 PHYSICAL CHARACTERISTICS			
					PAD P/N	PAD MAT'L	PAD P/N	PAD MAT'L
120-1064	1 Piston Floating Mount	1.75"	0.25"	4009				
120-1064-P	1 Piston Floating Mount - Polished	1.75"	0.25"	4009				
					150-1251K	BP-10		

Technical Tip

Pad Selection

Proper selection of a brake pad compound is critical to disc brake system performance. Each material has specific torque and wear characteristics relative to its operating temperature. Track conditions and driving style can also influence pad requirements. For best performance, final selection of pad material often requires evaluation at the track over a range of actual race conditions. Please reference pages 24-25 of this catalog, or visit our website at www.wilwood.com for descriptions of the various compounds available. You may also contact the Wilwood Customer Service Department at (805) 388-1188 for recommendations, or e-mail us at: support@wilwood.com.

Calipers

Kart / Jr. Dragster Calipers

- Designed specifically for racing and Weighs 1.20 pounds
- Can be mounted on either side of vehicle and comes in three rotor widths
- Internal fluid passage eliminates external crossover tubes
- Deep cup stainless steel piston for reduced heat transfer
- Specifically designed master cylinder is available for use with this caliper (see page 64)
- Comes in a bright blue anodized finish

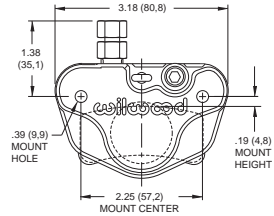

Caliper Ordering Information

PART NUMBER	DESCRIPTION	BORE SIZE	DISC WIDTH	PAD PLATE	PAD PLATE 4308 PHYSICAL CHARACTERISTICS
120-5499	2 Piston Body Mount	1.00"	0.50"	4308	
120-5750	2 Piston Body Mount	1.00"	0.19"	4308	
120-5498	2 Piston Body Mount	1.00"	0.12"	4308	
					PAD P/N PAD MAT'L PAD P/N PAD MAT'L 150-5602K CM (2 pack) 15H-5472K CM (each)

PS-1 Calipers

- Compact, lightweight at just .93 pounds
- Internal fluid passage eliminates external crossover tubes
- Two deep cup stainless steel pistons to minimize heat transfer from the .30" thick pads
- Fits rotors from .15" - .20" thick with diameters from 6.00" to 9.00"
- Clear anodized

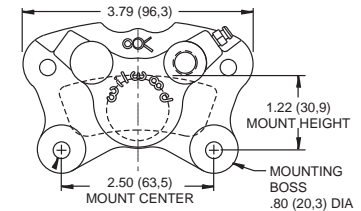

Caliper Ordering Information

PART NUMBER	DESCRIPTION	BORE SIZE	DISC WIDTH	PAD PLATE	PAD PLATE 4108 PHYSICAL CHARACTERISTICS
120-8373	2 Piston Lug Mount - RH	1.12"	0.19"	4108	
120-8374	2 Piston Lug Mount - LH	1.12"	0.19"	4108	
120-5453	2 Piston Lug Mount - RH	1.00"	0.19"	4108	
120-5456	2 Piston Lug Mount - LH	1.00"	0.19"	4108	
					PAD P/N PAD MAT'L 150-4091K CM

GP 200 Calipers

- Lightweight at just .90 pounds
- Fits rotors from 8.00" to 11.00" in diameter, and .25" thick while using a standard 2.38" lug mount
- Pad retaining pins provide easy access for pad service without caliper removal
- Utilizes a .34 cubic inch type 4908 pad
- Black anodized to provide a long lasting durable finish

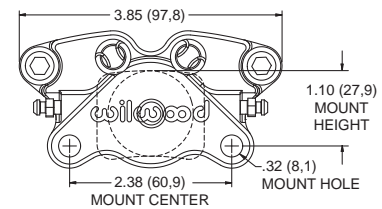

Caliper Ordering Information

PART NUMBER	DESCRIPTION	BORE SIZE	DISC WIDTH	PAD PLATE	PAD PLATE 4908 PHYSICAL CHARACTERISTICS
120-12178	2 Piston Lug Mount	1.25"	0.25"	4908	
					PAD P/N PAD MAT'L PAD P/N PAD MAT'L 150-12270K BP-10 150-12128K CM

OE Calipers

Original Equipment Manufacturer (OEM) Solutions

Willwood is best known for our automotive racing products, however, we also manufacture brakes for industrial and original equipment manufacturers including specialty vehicles, all-terrain vehicles, snowmobiles and the Army's H1 HUMVEE™, as well as brakes for amusement rides, agricultural vehicles, and heavy equipment. We have a large selection of off-the-shelf components, many of which are highlighted in this catalog. We specialize in the rapid development of custom brake components and brake systems and with over thirty years in disc brake engineering, proprietary tooling, and developing state-of-the-art production efficiencies, we are very competitive on cost.

SC-10 Two Piston Floating Calipers

- Compact, low profile sliding mount caliper
- High strength forged aluminum outboard anvil
- Two 1.06" aluminum pistons
- Weighing just 2.25 pounds including pads and bracket
- Standard M10 x 1.0 Thread inlet
- Increased pad area and volume with noise cancelling shields
- Fits rotors from .15" to .25" wide and 6.50" - 9.00" diameter

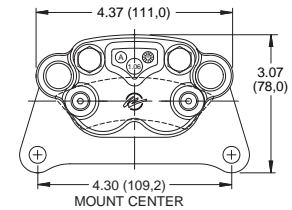

Caliper Ordering Information

PART NUMBER	DESCRIPTION	BORE SIZE	DISC WIDTH	PAD PLATE	PAD PLATE PHYSICAL CHARACTERISTICS
120-11644	2 Piston Floating Mount	1.06"	0.25"	—	<p>PAD P/N 150-11648 PAD MAT'L CM</p>

MC4 Mechanical Parking Brake Calipers

- Compact, low profile sliding mount caliper
- High strength forged aluminum outboard anvil
- Mechanical parking brake function
- Increased pad area and volume with noise cancelling shields
- Fits rotors from .81" wide and 11.00" - 12.88" diameter

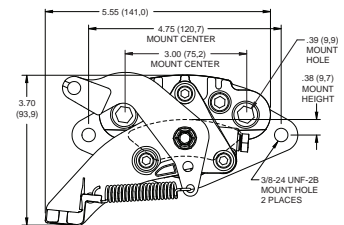

Caliper Ordering Information

PART NUMBER	DESCRIPTION	BORE SIZE	DISC WIDTH	PAD PLATE	PAD PLATE PHYSICAL CHARACTERISTICS
120-12069	1 Piston Floating Mount - R/H	1.19"	0.81"	—	<p>PAD P/N 150-7644 PAD MAT'L CM</p> <p>PAD P/N 150-8990 PAD MAT'L Organic</p>
120-12070	1 Piston Floating Mount - L/H	1.19"	0.81"	—	

OE Calipers

SC Caliper Series

- Die cast aluminum caliper is a strong, compact, inexpensive answer to the braking needs of recreational, agricultural and industrial vehicles
- Available in three bore sizes: 1.06", 1.19" or 1.25"
- Light weight starting at just 1.1 pounds
- Standard M10 x 1.0 banjo inlet
- Fits rotors from .15" to .25" wide

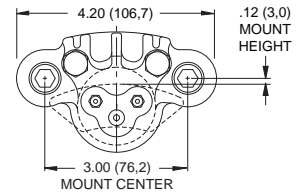

Caliper Ordering Information

PART NUMBER	DESCRIPTION	BORE SIZE	DISC WIDTH	PAD PLATE	PAD PLATE PHYSICAL CHARACTERISTICS			
					PAD P/N	PAD MAT'L	PAD P/N	PAD MAT'L
120-9851	SC1 - 1 Piston Floating Mount	1.25"	0.25"	—				
120-7183	SC2 - 1 Piston Floating Mount	1.19"	0.25"					
120-8787	SC3 - 1 Piston Floating Mount	1.06"	0.25"					
					PAD P/N	PAD MAT'L	PAD P/N	PAD MAT'L
					150-7644	CM	150-8990	Organic
					150-7646	CM		

DH4 Calipers

- Dual hydraulic caliper
- Lightweight at only 1.3 pounds
- Standard M10 x 1.0 banjo inlet
- Dust boot design to avoid dirt and moisture ingress
- Fits rotors .19" wide and 6.50" - 9.00" diameter
- Photo shown with optional bracket

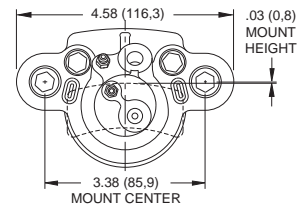

Caliper Ordering Information

PART NUMBER	DESCRIPTION	BORE SIZE	DISC WIDTH	PAD PLATE	PAD PLATE 4508 PHYSICAL CHARACTERISTICS			
					PAD P/N	PAD MAT'L	PAD P/N	PAD MAT'L
120-8476	1 Piston Floating Mount	1.50"	0.19"	4508				
					PAD P/N	PAD MAT'L	PAD P/N	PAD MAT'L
					150-5785	CM	150-9509	CM
					150-7192	CM	150-11648	CM

Hydra-Mechanical Calipers

- Compact, low profile sliding mount caliper
- Multi-clock position cartridge housing for mounting versatility
- Dust boot design to avoid dirt and moisture ingress
- Cable actuated mechanical parking brake, manual adjustment
- Accepts standard cable end fittings
- Fits rotors from .15" to .25" wide and 6.50" - 9.00" diameter
- Multiple pad compounds available

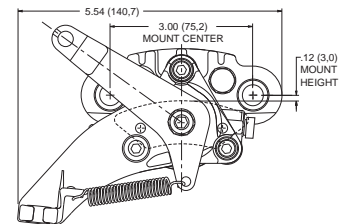

Caliper Ordering Information

PART NUMBER	DESCRIPTION	BORE SIZE	DISC WIDTH	PAD PLATE	PAD PLATE PHYSICAL CHARACTERISTICS			
					PAD P/N	PAD MAT'L	PAD P/N	PAD MAT'L
120-8841	1 Piston Floating Mount	1.19"	0.19"	—				
120-8842	1 Piston Floating Mount	1.19"	0.19"	—				
120-8792	1 Piston Floating Mount	1.00"	0.19"	—				
120-8793	1 Piston Floating Mount	1.00"	0.19"	—				
					PAD P/N	PAD MAT'L	PAD P/N	PAD MAT'L
					150-7644	CM	150-8990	Organic
					150-7646	CM		

Motorcycle Calipers

GP Series Motorcycle Calipers

Wilwood's GP 300 and GP 310 motorcycle disc brake calipers have been designed and engineered for use on 1984 - present Harley-Davidson® Motorcycles. Built around a 4-piston, high performance powerhouse, these billet aluminum calipers bring distinctive, bolt-on styling: Direct leg-mounted calipers are available for all single and dual disc models (except Springer and 4-speed FL models), as well as the 1983 XR 1000.

Rear calipers are available for all Softail®, Dyna, and touring models, utilizing unique bracket designs that combine the right elements of strength and style.

The GP 300 and GP 310 calipers are available in polished, brilliant chrome or black finishes, with the added performance characteristics found in Wilwood's racing calipers: Stainless steel pistons to reduce brake fade while resisting corrosion. High temperature piston seals extend life, control retraction and offer drag free operation. Additional features include bright-finish bleed screws and hardware, exclusive pad anti-rattle clip, and brake pads designed to operate in the widest range of temperatures and environments, utilizing our industry leading friction material, which is compatible with stainless steel rotors.



GP 300 Front



GP 310 Front



GP 310 Rear



GP 300 Rear w/Bracket
(bracket not included)

Caliper Ordering Information

DESCRIPTION	YEAR	POLISHED PART NO.	CHROME PART NO.	BLACK PART NO.	OPTIONAL BOLT KIT	BRAKE PAD SET (2)
GP 300 Front Left Hand Caliper (single)	1984-1999	120-3933-P	120-4243	—	230-4237	150-8733-2
GP 300 Front Right Hand Caliper	1984-1999	120-3945-P	120-4242	—	230-4237	150-8733-2
GP 300 Rear Caliper (bracket not included)	1984-1999	120-3935-P	120-4244	—	—	150-8733-2
GP 310 Front Left Hand Caliper (single)	1984-1999	120-7737-P	120-7737	120-7737-BK	230-4237	150-8733-2
GP 310 Front Right Hand Caliper	1984-1999	120-7736-P	120-7736	120-7736-BK	230-4237	150-8733-2
GP 310 Front Left Hand Caliper (single)	2000-2007	120-7739-P	120-7739	120-7739-BK	230-6330	150-8733-2
GP 310 Front Right Hand Caliper	2000-2007	120-7738-P	120-7738	120-7738-BK	230-6330	150-8733-2
GP 310 Front Left Hand Caliper (single)	2008-Up	120-12117-P	120-12117	120-12117-BK	230-6330	150-8733-2
GP 310 Front Right Hand Caliper	2008-Up	120-12116-P	120-12116	120-12116-BK	230-6330	150-8733-2
GP 310 Rear Right Hand Caliper (std 3.50" mount) ⁽¹⁾	—	120-7740-P	120-7740	120-7740-BK	230-4236	150-8733-2
GP 310 Rear Left Hand Caliper (std 3.50" mount) ^(1, 2)	—	120-7741-P	120-7741	120-7741-BK	230-4236	150-8733-2
GP 310 Rear Right Hand Caliper - Sprocket Brake ⁽¹⁾	—	120-10175-P	120-10175	120-10175-BK	230-4236	150-8733-2
GP 310 Rear Left Hand Caliper - Sprocket Brake ⁽¹⁾	—	120-10174-P	120-10174	120-10174-BK	230-4236	150-8733-2

NOTES:

(1) Bracket not included • (2) Use with Dyna "Bottom" bracket

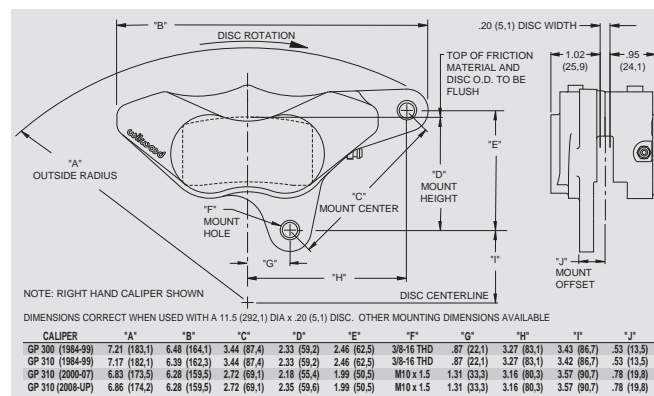

GP 310 Front and GP 300 Front/Rear Mounting Dimensions

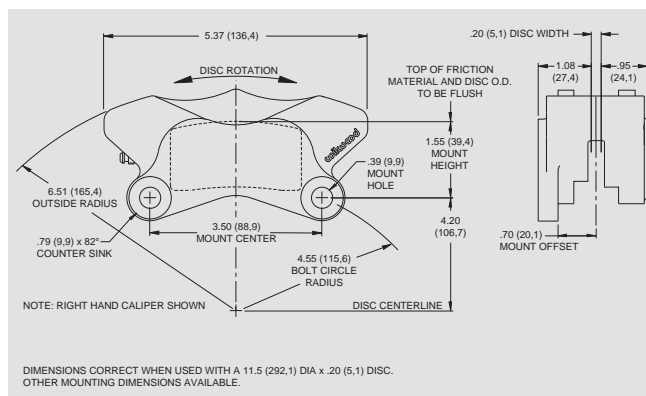

GP 310 Rear Mounting Dimensions

Motorcycle Brackets/Rotors

GP 310 Rear Caliper Mounting Brackets

Wilwood motorcycle brackets are a perfect fit for our GP caliper series. Manufactured to precise specifications to guarantee an easy bolt-on installation. Most are available in a deep mirror polish, or a beautiful chrome finish except for the GP 300 bracket kit is only available in our proprietary black E-coat finish.

Ordering Information

DESCRIPTION	YEAR	POLISHED PART NO.	CHROME PART NO.	BLACK PART NO.
GP 300 Softail® Bracket Kit (shown previous page)	1984-1999	—	—	250-4235
GP 310 Softail® Bracket Kit	1984-1999	250-8035-P	250-8035	—
GP 310 Softail® Bracket Kit	2000-Up	250-8036-P	250-8036	—
Dyna Bracket Kit	1984-1999	250-8034-P	250-8034	—
Dyna Bracket Kit	2000-Up	250-8033-P	250-8033	—
Dyna "Bottom" Bracket Kit ⁽¹⁾	1984-1999	250-8252-P	250-8252	—
FLH / FLT Bracket Kit	2000-2006	250-10165-P	250-10165	—

NOTES: (1) Locates caliper on the bottom side of the rotor. Use with left hand GP 310 rear caliper.
(2) Optional mounting bolt kit, part number 230-4236 is included with brackets.



GP Series Motorcycle Rotors

Wilwood motorcycle rotors combine the ultimate in performance and distinctive style for production bikes and full customs using OE dimension brake components. These stainless steel rotors are available in three finishes, second-to-none deep mirror polish, a beautiful satin finish, or our proprietary black E-coat finish. These rotors are matched with our friction materials to provide the stopping power you expect from the world leader in high performance disc brake systems.

Front and rear kit rotors are available for most models from 1984 through 2006 that use 11.50" diameter discs with the 5 x 3.25" mounting pattern. Symmetrical front rotors can be used on single or twin front caliper models.

These rotors can be used as a direct replacement with the OE calipers, or coupled with Wilwood GP calipers while providing a precision fit without run-out or knock-back for smooth engagement at all speeds.



11.50" Front Rotor



11.50" Rear Rotor

Rotor Ordering Information

DIAMETER	WIDTH	BOLT CIRCLE	HOLE TYPE	MODEL YEAR	FRONT/ REAR	POLISHED PART NO.	SATIN PART NO.	BLACK PART NO.
11.50" (292,1)	.196" (5,0)	5 x 3.25" (82,6)	.344"	1984-1999	FRONT	160-9913P	160-10662	160-10662-BK
11.50" (292,1)	.196" (5,0)	5 x 3.25" (82,6)	.422"	1984-1999	REAR	160-9914P	160-10662	160-10663-BK
11.50" (292,1)	.196" (5,0)	5 x 3.25" (82,6)	.344"	2000-UP	FRONT	160-9915P	160-10664	160-10664-BK
11.50" (292,1)	.196" (5,0)	5 x 3.25" (82,6)	.422"	2000-UP	REAR	160-9916P	160-10665	160-10665-BK

Technical Tip

Motorcycle Brake Fluid

When changing brake calipers, it is a good idea to put in fresh fluid. **Unlike all other racing applications mentioned in this catalog, Harley-Davidson® Motorcycles use DOT 5 silicon fluid, which has different characteristics than DOT 3, DOT 4, or DOT 5.1 Racing Brake Fluid.** The primary reason for using DOT 5 fluid with street bikes is to prevent paint damage should brake fluid be spilled or dripped on fenders, gas tanks, etc. DOT 3, 4, or 5.1 Racing Brake Fluid is superior for high performance racing applications, however, it is corrosive to paint. Wilwood racing and performance calipers will work with either DOT 3, 4, 5, or 5.1 brake fluid, but it should be emphasized that DOT 5 silicon fluid should **NEVER** be mixed with DOT 3, 4, or 5.1 fluids, or used in a high performance application. Replace your factory DOT 5 silicon brake fluid with another DOT 5 type, or flush out your brake system and replace it with a high performance DOT 3, 4, or 5.1 fluid, taking care not to spill on any paint surfaces and taking note of proper use instructions.

Thermlock® Pistons

Thermlock® Piston Technology



Wilwood's exclusive Thermlock® Pistons provide the most effective thermal barrier available for minimizing heat transfer from the brake pads to the caliper body, seals, and fluid. This innovative multi-part design incorporates a stainless steel shield and coated aluminum shell configuration

that effectively retards heat transfer by 25% or more. Lower operating temperatures translate to the elimination of seal crystallization, the elimination of localized fluid boiling, and longer service life through decreased distortion in the caliper body and piston bores. This technology was originally developed for the extreme temperatures and sustained high heat realized in NASCAR and professional category road racing. The applications now cover all the popular Wilwood calipers used for extreme duty short track and road course competition.

Thermlock® T1 pistons are the latest intermediate and short length designs used as standard equipment in all TC6R, W6AR, W4AR, Forged Narrow Superlite, DynaPro, Dynalite, and GN III caliper models that include the "ST" model designation.

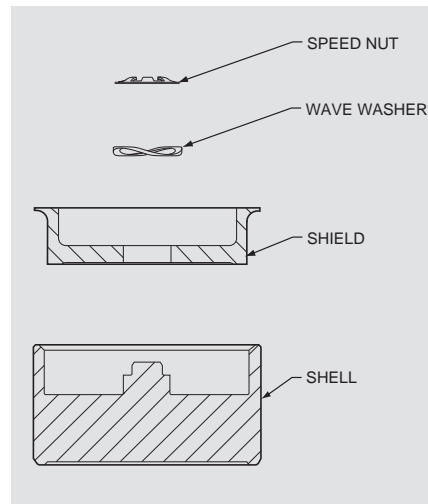

**Thermlock® T1 Piston,
Exploded View**

Ordering Information

PART NO.	DIAMETER	LENGTH	CALIPER APPLICATIONS
T1 Piston			
200-7550	1.88"	1.05"	W6AR, W4AR, Superlite
200-7551	1.75"	1.05"	W6AR, W4AR, SL, NDL, NDP, GN III
200-7552	1.75"	0.88"	TC6R, Dynalite, DynaPro
200-7553	1.62"	1.05"	W6AR, W4AR, Superlite, NDL, NDP
200-7554	1.38"	1.05"	W6AR, W4AR, SL, NDL, NDP, GN III
200-7555	1.25"	1.05"	W6AR, W4AR, Superlite, IR-GT
200-7556	1.12"	1.05"	W6AR, W4AR, Superlite, IR-GT, NDL, NDP
200-7557	1.00"	1.05"	Superlite, IR-GT, NDL, NDP
200-9615	1.62"	0.88"	TC6R, BNSL6R, Dynalite, DynaPro
200-9616	1.38"	0.88"	TC6R, Dynalite, DynaPro
200-11342	1.12"	0.88"	TC6R, BNSL6R, Dynalite, DynaPro
200-11343	1.25"	0.88"	TC6R, Dynalite, DynaPro



Brake Pads

Brake Pad Characteristics

To determine the best brake pad compound for your particular brake system setup, review the performance characteristics and popular application guidelines below. Ultimately, the optimum pad compound for any given application and driver's preference can only be found after actual on-track testing and evaluation. Compound types and ordering information for the pads used in Wilwood calipers can be found within the individual caliper pages.

Compound Performance Range Data

General Characteristics and Popular Applications

A	Heat Range: X-High Cold Torque: X-High Hot Torque: X-High Wear Rate: Low	<ul style="list-style-type: none"> • Immediate cold response with highest friction values at all temperatures • Severe duty use on oval tracks, road courses, and other applications that require immediate high torque response • Long wear rate for sustained high heat braking • Compatible with all iron, steel, and titanium rotors
BP-40	Heat Range: X-High Cold Torque: Medium-High Hot Torque: X-High Wear Rate: Medium-Low	<ul style="list-style-type: none"> • Improved friction formula for heavy braking asphalt ovals, extreme braking on dirt, and all types of off-road and road course applications • Predictable and linear response with excellent modulation • Long wear rates with iron and steel rotors • Titanium compatible
H	Heat Range: X-High Cold Torque: High Hot Torque: X-High Wear Rate: Low	<ul style="list-style-type: none"> • Smooth initial engagement with a linear increase as heat and pressure rise • Severe duty use for road courses and hard braking ovals • Predictable response with excellent modulation at all temperatures • Long wear rate for durability in sustained high heat • Compatible with all iron, steel, and titanium rotors
BP-30	Heat Range: High Cold Torque: Medium Hot Torque: High Wear Rate: Medium-Low	<ul style="list-style-type: none"> • Improved friction formula for intermediate asphalt ovals and hard braking dirt tracks • Light to intermediate duty road courses • Beds quickly with low rotor abrasion and long wear • Compatible with all iron, steel, and titanium rotors
B	Heat Range: High Cold Torque: Medium Hot Torque: High Wear Rate: Medium	<ul style="list-style-type: none"> • Traditional favorite for asphalt LM's, modifieds, and sprints • Modifieds, late models, and other hard braking dirt applications • Intermediate weight road course, auto-cross, rally • Beds easily and fully compatible with all iron, steel, and titanium rotors
C	Heat Range: X-High Cold Torque: Low Hot Torque: Medium Wear Rate: Low	<ul style="list-style-type: none"> • Gradual rise from to medium torque as temperature increases • Long wear and high temperature fade resistance • Tuning pad for reduced response in medium to high temperature ranges • Compatible with all iron and steel alloy rotors
CM	Heat Range: High Cold Torque: Medium Hot Torque: High Wear Rate: Low	<ul style="list-style-type: none"> • Composite metallic compound for high temperature durability on titanium and other low conductive alloy rotors • Long wear rates and highest fade resistance in sustained heat • Baseline for inboard sprint brakes with titanium or stainless rotors
E	Heat Range: Medium Cold Torque: Medium Hot Torque: Medium Wear Rate: Medium	<ul style="list-style-type: none"> • Consistent, linear response through temperature range • Baseline for light to intermediate dirt applications with vented iron rotors • Drag racing with steel rotors • Auto-cross and lighter duty road racing

Brake Pads

Brake Pad Characteristics

Compound	Performance Range Data	General Characteristics and Popular Applications
BP-20	Heat Range: Medium-High Cold Torque: Medium Hot Torque: Medium-High Wear Rate: Medium	<ul style="list-style-type: none"> • High performance street compound with increased friction and a wider temperature range over BP-10 • Beds quickly and provides fast response without high rotor abrasion • Baseline pad for track oriented street cars
BP-10	Heat Range: Medium Cold Torque: Medium Hot Torque: Medium Wear Rate: Medium	<ul style="list-style-type: none"> • High performance street compound with improved friction, longer wear and lower dust levels than standard replacement pads • Beds quickly and provides fast response without high rotor abrasion • Baseline pad compound for most disc conversion and upgrade kits
Q	Heat Range: Medium-Low Cold Torque: Medium Hot Torque: Medium Wear Rate: Medium	<ul style="list-style-type: none"> • High performance ceramic based street formula • Lowest dust and noise • Compatible with all types of steel or iron rotors • Also compatible with aluminum rotors on sprint cars
PM	Heat Range: High Cold Torque: Medium Hot Torque: Medium-Medium Wear Rate: Usage Based	<ul style="list-style-type: none"> • True dual-sport Pro-Matrix performance street and track compound • Quiet running with lowered dust than OE compounds • Unique composite formula provides clean, quiet, and long running on the street, with high friction and high temperature fade resistant to withstand extreme braking cycles during auto-cross and track day events.

Brake Pad Bedding

Bedding is a "real conditions" heat cycle and the final step in preparing the pads for service. All pads, even OE stock replacement parts, will benefit from a proper bedding cycle. Bedding can be done either in the vehicle, or on a special bedding dyno that can realistically duplicate the torque loads, pressure, and temperature that will be experienced in the vehicle.

The bedding process is the final "heat cure" for the pads. This final bedding cure differs from an oven heat cure in such that the oven heat cure does not include the pressure, torque, and elevated surface temperatures that are necessary to properly condition the pad for service. New pads must be deliberately brought up to temperature through a series of controlled cycles and then slowly cooled. If the pads are put into hard service right from the start, damage from fractures or accelerated deterioration due to extreme temperature variations between the surface and the body of the pad can occur.

Once the brake system has been tested and determined safe to operate the vehicle, follow these steps for bedding of all pad materials.

1. Proceed with a series of 8-10 hard stops from 55-65 MPH down to 25 MPH allowing 20-30 seconds of cool down time between each stop.
2. Drive at a moderate cruising speed, with the least amount of brake contact possible, until most of the heat has dissipated from the brakes. Avoid sitting stopped with the brake pedal depressed to hold the car in place during this time. Park the vehicle and allow the brakes to cool to ambient air temperature.

During the bedding process, a more positive feel from the brakes should develop. This is an indication that the bed in process is working. If any level of brake fade is observed during the hard stops, it may be an indication that the brakes have been more than adequately heated. Begin cooling the brakes with light driving and without brake contact immediately.

Rotors

Rotor Performance:

Wilwood Engineering produces over 120 different types of premium rotors designed specifically for racing and high performance applications. Although a rotor's basic function is to disperse energy (in the form of heat) created by the brake pads clamping onto the rapidly rotating rotor, how well a rotor performs this job under the extremes of racing is why Wilwood rotors are considered the best in the industry.

Wilwood vented rotors are designed for maximum cooling. The internal vanes pump cool air from the center of the wheel and take heat away from the rotor, allowing rotor temperatures to decrease. Wilwood has designed special curved vane and straight vane rotors to effectively move large volumes of air to rapidly disperse this heat (energy). Specially formulated iron is used to enhance the stability of the rotor, while allowing difficult castings in complex vane configurations to be produced. Wilwood's proprietary casting techniques are the result of over 35 years of vented rotor research and development combined with actual on-track performance evaluation. All rotors are precision machined to assure surfaces are flat and parallel.

Our premier **Spec 37** rotor material is a proprietary iron alloy developed to withstand extreme temperatures with the highest possible degree of resistance against distortion, warping, cracking, and wear. The formulation for this alloy is a derivative of technology and materials that were significant in the development of the extreme duty military spec rotors that are manufactured by Wilwood. The **Spec 37** motorsports alloy was reformulated to better suit it to the sometimes sudden temperature changes, as well as the sustained high heat cycles that occur in hard braking events. **Spec 37** rotors have delivered never-before seen durability in some of the most grueling short oval and road course racing conditions, outperforming other rotor brands with longer wear and true running. Additionally, every **Spec 37** rotor is precision machined to less than .001" run-out, flatness, and parallelism.

Wilwood steel rotors are used when rapid thermal inputs occur and extreme material stability is required (i.e. when a dragster must brake from 300 mph). Under such conditions specialty steels are used, often cross drilled to reduce rotational weight. Wilwood super alloy rotors and aluminum rotors offer maximum weight savings in open wheel and other specialty markets.

For all rotor designs, Wilwood conducts extensive in-house dynamometer testing to measure results of rotors under the most demanding conditions. This unique testing, teamed with extensive metallurgical research, development and track testing assure the racer of the best quality high performance rotors available.

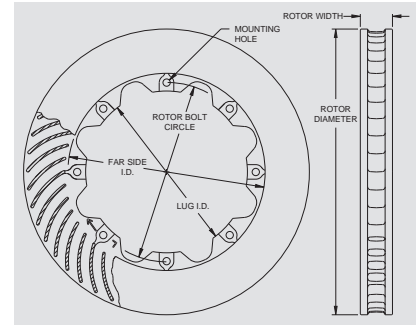

How to Determine Rotor Physical Measurements

SV-GT Staggered Directional Vane Rotors



SV-GT curved vane rotors are built for the extreme conditions of professional motorsports. The superior heat absorption and dissipation characteristics of these heavy wall directional vane rotors are the keys to preventing heat fade and realizing long service life from the rotors and pads. All rotors are cast from premium grade, long grain carbon iron for long wear, thermal stability, and resistance to distortion. Every GT rotor is fully detail machined to eliminate stress points and unnecessary weight away from the pad sweep face. The faces and O.D. are precision turned to less than .001" for flatness, parallelism, and run-out. An asymmetrical face slot pattern provides smoother engagement through reduced harmonics and improved thermal balance between the I.D. and O.D. of the rotor. Every rotor is then individually dynamic balanced to provide vibration free performance at any speed. These rotors provide the highest cooling capacity and longest service life for extreme braking short tracks and road course competition.

Rotor Ordering Information

DIAMETER	WIDTH	BOLT CIRCLE	HOLE TYPE	FAR SIDE I.D.	LUG I.D.	WEIGHT LBS	RH / LH	PART NUMBER
16.00" (406,4)	1.38" (35,1)	12 x 10.75" (273,1)	.315"	11.76" (298,7)	10.00" (254,0)	22.5	R/H	160-8953
16.00" (406,4)	1.38" (35,1)	12 x 10.75" (273,1)	.315"	11.76" (298,7)	10.00" (254,0)	22.5	L/H	160-8954
14.25" (362,0)	1.25" (31,8)	12 x 9.18" (233,4)	.251"	10.00" (254,0)	8.63" (219,2)	18.7	R/H	160-9787⁽¹⁾
14.25" (362,0)	1.25" (31,8)	12 x 9.18" (233,4)	.251"	10.00" (254,0)	8.63" (219,2)	18.7	L/H	160-9788⁽¹⁾
14.25" (362,0)	1.25" (31,8)	12 x 8.75" (222,3)	.251"	10.00" (254,0)	8.25" (209,6)	18.8	R/H	160-11315⁽¹⁾
14.25" (362,0)	1.25" (31,8)	12 x 8.75" (222,3)	.251"	10.00" (254,0)	8.25" (209,6)	18.8	L/H	160-11316⁽¹⁾
14.25" (362,0)	1.10" (27,9)	12 x 8.75" (222,3)	.251"	10.00" (254,0)	8.25" (209,6)	18.8	R/H	160-11311⁽¹⁾
14.25" (362,0)	1.10" (27,9)	12 x 8.75" (222,3)	.251"	10.00" (254,0)	8.25" (209,6)	18.8	L/H	160-11312⁽¹⁾
14.00" (355,6)	1.25" (31,8)	12 x 9.18" (233,2)	.251"	10.00" (254,0)	8.57" (217,7)	17.3	R/H	160-8023⁽¹⁾
14.00" (355,6)	1.25" (31,8)	12 x 9.18" (233,2)	.251"	10.00" (254,0)	8.57" (217,7)	17.3	L/H	160-8024⁽¹⁾
14.00" (355,6)	1.25" (31,8)	12 x 8.75" (222,2)	.251"	10.00" (254,0)	8.25" (209,6)	17.5	R/H	160-8398⁽¹⁾
14.00" (355,6)	1.25" (31,8)	12 x 8.75" (222,2)	.251"	10.00" (254,0)	8.25" (209,6)	17.5	L/H	160-8399⁽¹⁾
14.00" (355,6)	1.10" (27,9)	12 x 8.75" (222,2)	.251"	10.00" (254,0)	8.25" (209,6)	14.7	R/H	160-8402⁽¹⁾
14.00" (355,6)	1.10" (27,9)	12 x 8.75" (222,2)	.251"	10.00" (254,0)	8.25" (209,6)	14.7	L/H	160-8403⁽¹⁾

NOTES:

For Dyno bedded rotors, add -B to the end of the part number when ordering.

(1) **Bold** text denotes Spec 37 rotor material. Please check our website for more information on Spec 37 rotors and configurations.

Rotors



wilwood

www.wilwood.com

wilwood

GT-32 / GT-36 / GT-40 / GT-48 Curved Vane Rotors



GT curved vane rotors are built for the extreme conditions of professional motorsports. The superior heat absorption and dissipation characteristics of these heavy wall directional vane rotors are the keys to preventing heat fade and realizing long service life from the rotors and pads. All rotors are cast from premium grade, long grain carbon iron for long wear, thermal stability, and resistance to distortion. Every GT rotor is fully detail machined to eliminate stress points and unnecessary weight away from the pad sweep face. The faces and O.D. are precision turned to less than .001" for flatness, parallelism, and run-out. An asymmetrical face slot pattern provides smoother engagement through reduced harmonics and improved thermal balance between the I.D. and O.D. of the rotor. Every rotor is then individually dynamic balanced to provide vibration free performance at any speed. These rotors provide the highest cooling capacity and longest service life for extreme braking short tracks and road courses.

Rotor Ordering Information

DIAMETER	WIDTH	BOLT CIRCLE	HOLE TYPE	FAR SIDE I.D.	LUG I.D.	WEIGHT LBS	RH / LH	PART NUMBER
15.00" (381,0)	1.25" (31,8)	12 x 8.75" (222,3)	.251"	10.67" (271,0)	6.25" (158,8)	15.4	R/H	160-11754
15.00" (381,0)	1.25" (31,8)	12 x 8.75" (222,3)	.251"	10.67" (271,0)	6.25" (158,8)	15.4	L/H	160-11755
14.00" (355,6)	1.25" (31,8)	12 x 8.25" (209,6)	.251"	9.01" (228,9)	7.75" (196,9)	21.6	R/H	160-12391 ⁽¹⁾
14.00" (355,6)	1.25" (31,8)	12 x 8.25" (209,6)	.251"	9.01" (228,9)	7.75" (196,9)	21.6	L/H	160-12392 ⁽¹⁾
13.06" (331,7)	1.38" (35,0)	8 x 7.00" (177,8)	.313"	9.21" (233,9)	6.53" (165,9)	16.0	R/H	160-3584 ⁽¹⁾
13.06" (331,7)	1.38" (35,0)	8 x 7.00" (177,8)	.313"	9.21" (233,9)	6.53" (165,9)	16.0	L/H	160-3585 ⁽¹⁾
13.06" (331,7)	1.25" (31,8)	12 x 8.75" (222,3)	.251"	9.46" (240,3)	8.25" (209,6)	12.3	R/H	160-8165 ⁽¹⁾
13.06" (331,7)	1.25" (31,8)	12 x 8.75" (222,3)	.251"	9.46" (240,3)	8.25" (209,6)	12.3	L/H	160-8166 ⁽¹⁾
13.00" (330,2)	1.10" (27,9)	12 x 7.00" (177,8)	.251"	8.57" (217,7)	6.38" (162,0)	14.6	R/H	160-8508
13.00" (330,2)	1.10" (27,9)	12 x 7.00" (177,8)	.251"	8.57" (217,7)	6.38" (162,0)	14.6	L/H	160-8509
12.90" (327,7)	1.38" (35,0)	12 x 7.17" (182,0)	8 mm	7.86" (199,7)	6.25" (158,8)	19.3	R/H	160-6843 ⁽¹⁾
12.90" (327,7)	1.38" (35,0)	12 x 7.17" (182,0)	8 mm	7.86" (199,7)	6.25" (158,8)	19.3	L/H	160-6844 ⁽¹⁾
12.88" (327,2)	1.38" (35,0)	12 x 7.00" (177,8)	.251"	8.05" (204,5)	6.55" (166,4)	18.6	R/H	160-4932 ⁽¹⁾
12.88" (327,2)	1.38" (35,0)	12 x 7.00" (177,8)	.251"	8.05" (204,5)	6.55" (166,4)	18.6	L/H	160-4933 ⁽¹⁾
12.88" (327,2)	1.25" (31,8)	12 x 8.75" (222,3)	.251"	9.46" (240,3)	8.25" (209,6)	11.7	R/H	160-4564 ⁽¹⁾
12.88" (327,2)	1.25" (31,8)	12 x 8.75" (222,3)	.251"	9.46" (240,3)	8.25" (209,6)	11.7	L/H	160-4565 ⁽¹⁾
12.88" (327,2)	1.10" (27,9)	12 x 8.75" (222,3)	.251"	9.46" (240,3)	8.25" (209,6)	12.3	R/H	160-6833
12.88" (327,2)	1.10" (27,9)	12 x 8.75" (222,3)	.251"	9.46" (240,3)	8.25" (209,6)	12.3	L/H	160-6834
12.88" (327,2)	1.00" (25,4)	12 x 8.75" (222,3)	.251"	9.46" (240,3)	8.25" (209,6)	10.5	R/H	160-7597
12.88" (327,2)	1.00" (25,4)	12 x 8.75" (222,3)	.251"	9.46" (240,3)	8.25" (209,6)	10.5	L/H	160-7598
12.88" (327,2)	.81" (20,6)	12 x 8.75" (222,3)	.251"	9.46" (240,3)	8.25" (209,6)	10.1	R/H	160-9959
12.88" (327,2)	.81" (20,6)	12 x 8.75" (222,3)	.251"	9.46" (240,3)	8.25" (209,6)	10.1	L/H	160-9960
12.80" (325,1)	1.25" (31,8)	12 x 7.06" (179,3)	.251"	8.41" (213,6)	6.53" (165,9)	15.0	R/H	160-7742 ⁽¹⁾
12.80" (325,1)	1.25" (31,8)	12 x 7.06" (179,3)	.251"	8.41" (213,6)	6.53" (165,9)	15.0	L/H	160-7743 ⁽¹⁾
12.72" (323,0)	1.38" (35,0)	12 x 6.75" (171,5)	.251"	7.69" (195,3)	6.25" (158,8)	18.7	R/H	160-3314 ⁽¹⁾
12.72" (323,0)	1.38" (35,0)	12 x 6.75" (171,5)	.251"	7.69" (195,3)	6.25" (158,8)	18.7	L/H	160-3315 ⁽¹⁾
12.72" (323,0)	1.25" (31,8)	8 x 7.62" (193,5)	5/16-24	8.88" (225,6)	7.13" (181,1)	13.0	R/H	160-2978 ⁽¹⁾
12.72" (323,0)	1.25" (31,8)	8 x 7.62" (193,5)	5/16-24	8.88" (225,6)	7.13" (181,1)	13.0	L/H	160-2979 ⁽¹⁾
12.72" (323,0)	1.25" (31,8)	8 x 7.00" (177,8)	.313"	8.88" (225,6)	6.53" (165,9)	13.4	R/H	160-2540 ⁽¹⁾
12.72" (323,0)	1.25" (31,8)	8 x 7.00" (177,8)	.313"	8.88" (225,6)	6.53" (165,9)	13.4	L/H	160-2541 ⁽¹⁾
12.60" (320,0)	1.25" (31,8)	12 x 7.00" (177,8)	.251"	7.69" (195,3)	6.38" (162,0)	15.6	R/H	160-8746 ⁽¹⁾
12.60" (320,0)	1.25" (31,8)	12 x 7.00" (177,8)	.251"	7.69" (195,3)	6.38" (162,0)	15.6	L/H	160-8747 ⁽¹⁾
12.19" (309,7)	1.38" (35,0)	8 x 7.00" (177,8)	.313"	8.41" (213,6)	6.53" (165,9)	13.5	R/H	160-2684 ⁽¹⁾
12.19" (309,7)	1.38" (35,0)	8 x 7.00" (177,8)	.313"	8.41" (213,6)	6.53" (165,9)	13.5	L/H	160-2685 ⁽¹⁾
12.19" (309,7)	1.25" (31,8)	8 x 7.00" (177,8)	.313"	8.41" (213,6)	6.53" (165,9)	12.7	R/H	160-11839 ⁽¹⁾
12.19" (309,7)	1.25" (31,8)	8 x 7.00" (177,8)	.313"	8.41" (213,6)	6.53" (165,9)	12.7	L/H	160-11840 ⁽¹⁾
12.19" (309,7)	.81" (20,6)	8 x 7.62" (193,5)	5/16-24	8.41" (213,6)	7.13" (181,1)	9.3	R/H	160-12293 ⁽¹⁾
12.19" (309,7)	.81" (20,6)	8 x 7.62" (193,5)	5/16-24	8.41" (213,6)	7.13" (181,1)	9.3	L/H	160-12294 ⁽¹⁾
12.19" (309,7)	.81" (20,6)	8 x 7.00" (177,8)	.325"	8.34" (211,8)	6.38" (162,0)	9.6	R/H	160-12291 ⁽¹⁾
12.19" (309,7)	.81" (20,6)	8 x 7.00" (177,8)	.325"	8.34" (211,8)	6.38" (162,0)	9.6	L/H	160-12292 ⁽¹⁾
12.00" (304,8)	.81" (20,6)	8 x 7.00" (177,8)	.325"	8.41" (213,6)	6.38" (162,0)	9.0	R/H	160-12287 ⁽¹⁾
12.00" (304,8)	.81" (20,6)	8 x 7.00" (177,8)	.325"	8.41" (213,6)	6.38" (162,0)	9.0	L/H	160-12288 ⁽¹⁾
11.75" (298,5)	1.25" (31,8)	8 x 7.00" (177,8)	.313"	8.34" (211,8)	6.38" (162,0)	11.3	R/H	160-11837 ⁽¹⁾
11.75" (298,5)	1.25" (31,8)	8 x 7.00" (177,8)	.313"	8.34" (211,8)	6.38" (162,0)	11.3	L/H	160-11838 ⁽¹⁾
11.75" (298,5)	.81" (20,6)	8 x 7.00" (177,8)	.325"	7.87" (199,9)	6.38" (162,0)	9.0	R/H	160-12285 ⁽¹⁾
11.75" (298,5)	.81" (20,6)	8 x 7.00" (177,8)	.325"	7.87" (199,9)	6.38" (162,0)	9.0	L/H	160-12286 ⁽¹⁾

NOTES:

For Dyno bedded rotors, add -B to the end of the part number when ordering.

(1) **Bold** text denotes Spec 37 rotor material. Please check our website for more information on Spec 37 rotors and configurations..

Rotors

HD Series Directional Vane Rotors



HD-48, HD-40, and HD-36 Series directional vane rotors provide superior thermal stability and long service for asphalt late models, modifieds, open wheel, and most other types of high heat competition applications. All HD rotors are cast from premium grade, long grain carbon iron for long wear, high thermal stability and resistance to distortion. Thick wall pad sweep faces with directional cooling vanes provide superior heat absorption and dissipation qualities to prevent heat fade and realize long service life from the pads and rotors. All HD rotor faces are precision turned to less than .001" for flatness, parallelism, and run-out for smoother engagement and reduced vibration.

Rotor Ordering Information

DIAMETER	WIDTH	BOLT CIRCLE	HOLE TYPE	FAR SIDE I.D.	LUG I.D.	WEIGHT LBS	RH / LH	PART NUMBER
13.06" (331,7)	1.25" (31,8)	12 x 8.75" (222,3)	.251"	9.46" (240,3)	8.25" (209,6)	12.3	R/H	160-12786 ⁽¹⁾
13.06" (331,7)	1.25" (31,8)	12 x 8.75" (222,3)	.251"	9.46" (240,3)	8.25" (209,6)	12.3	L/H	160-12787 ⁽¹⁾
12.88" (327,2)	1.25" (31,8)	12 x 8.75" (222,3)	.251"	9.46" (240,3)	8.25" (209,6)	11.7	R/H	160-12784 ⁽¹⁾
12.88" (327,2)	1.25" (31,8)	12 x 8.75" (222,3)	.251"	9.46" (240,3)	8.25" (209,6)	11.7	L/H	160-12785 ⁽¹⁾
12.19" (309,7)	1.25" (31,8)	8 x 7.62" (193,6)	5/16-24	8.41" (213,6)	6.90" (175,3)	12.7	R/H	160-3872 ⁽¹⁾
12.19" (309,7)	1.25" (31,8)	8 x 7.62" (193,6)	5/16-24	8.41" (213,6)	6.90" (175,3)	12.7	L/H	160-3873 ⁽¹⁾
12.19" (309,7)	1.25" (31,8)	8 x 7.00" (177,8)	.313"	8.41" (213,6)	6.53" (165,9)	12.7	R/H	160-11835 ⁽¹⁾
12.19" (309,7)	1.25" (31,8)	8 x 7.00" (177,8)	.313"	8.41" (213,6)	6.53" (165,9)	12.7	L/H	160-11836 ⁽¹⁾
12.19" (309,7)	.81" (20,6)	8 x 7.00" (177,8)	.325"	8.34" (211,8)	6.38" (162,0)	9.5	R/H	160-12289 ⁽¹⁾
12.19" (309,7)	.81" (20,6)	8 x 7.00" (177,8)	.325"	8.34" (211,8)	6.38" (162,0)	9.5	L/H	160-12290 ⁽¹⁾
11.75" (298,5)	1.25" (31,8)	8 x 7.00" (177,8)	.313"	8.34" (211,8)	6.38" (162,0)	10.9	R/H	160-3846
11.75" (298,5)	1.25" (31,8)	8 x 7.00" (177,8)	.313"	8.34" (211,8)	6.38" (162,0)	10.9	L/H	160-3847
11.75" (298,5)	1.25" (31,8)	8 x 7.00" (177,8)	.313"	8.34" (211,8)	6.38" (162,0)	11.3	R/H	160-11611 ⁽¹⁾
11.75" (298,5)	1.25" (31,8)	8 x 7.00" (177,8)	.313"	8.34" (211,8)	6.38" (162,0)	11.3	L/H	160-11612 ⁽¹⁾
11.75" (298,5)	.81" (20,6)	8 x 7.00" (177,8)	.325"	7.87" (199,9)	6.38" (162,0)	8.5	R/H	160-12283 ⁽¹⁾
11.75" (298,5)	.81" (20,6)	8 x 7.00" (177,8)	.325"	7.87" (199,9)	6.38" (162,0)	8.5	L/H	160-12284 ⁽¹⁾

NOTES:

(1) **Bold** text denotes Spec 37 rotor material. Please check our website for more information on Spec 37 rotors and configurations.

UL-32 Series Directional Vane Rotors

Ultra-Light UL-32 and ULHP-32 directional vane rotors provide an excellent balance of efficient cooling and lower rotating mass on hard braking dirt tracks or rear axle service on pavement cars. UL rotors are cast from premium grade, long grain carbon iron for long wear, high thermal stability, and resistance to distortion. UL-32 rotors are production machined and well suited to a wide range of sportsman racing categories. ULHP-32 rotors offered the added performance and smoother operation of precision turned faces with less than .001" variation in flatness, parallelism, or run-out.



Rotor Ordering Information

DIAMETER	WIDTH	BOLT CIRCLE	HOLE TYPE	FAR SIDE I.D.	LUG I.D.	WEIGHT LBS	RH / LH	PART NUMBER
ULHP-32 Series								
12.19" (309,7)	1.25" (31,8)	8 x 7.00" (177,8)	.325"	8.50" (215,9)	6.38" (162,0)	10.4	R/H	160-5845
12.19" (309,7)	1.25" (31,8)	8 x 7.00" (177,8)	.325"	8.50" (215,9)	6.38" (162,0)	10.4	L/H	160-5846
11.75" (298,5)	1.25" (31,8)	8 x 7.00" (177,8)	.325"	8.34" (211,8)	6.38" (162,0)	9.6	R/H	160-5847
11.75" (298,5)	1.25" (31,8)	8 x 7.00" (177,8)	.325"	8.34" (211,8)	6.38" (162,0)	9.6	L/H	160-5848
UL-32 Series								
12.19" (309,7)	1.25" (31,8)	8 x 7.62" (193,6)	5/16-24	8.50" (215,9)	7.13" (181,1)	10.1	R/H	160-2900
12.19" (309,7)	1.25" (31,8)	8 x 7.62" (193,6)	5/16-24	8.50" (215,9)	7.13" (181,1)	10.1	L/H	160-2901
12.19" (309,7)	1.25" (31,8)	8 x 7.00" (177,8)	.325"	8.50" (215,9)	6.38" (162,0)	10.5	R/H	160-2894
12.19" (309,7)	1.25" (31,8)	8 x 7.00" (177,8)	.325"	8.50" (215,9)	6.38" (162,0)	10.5	L/H	160-2895
11.75" (298,5)	1.25" (31,8)	8 x 7.00" (177,8)	.325"	8.34" (211,8)	6.38" (162,0)	9.6	R/H	160-2898
11.75" (298,5)	1.25" (31,8)	8 x 7.00" (177,8)	.325"	8.34" (211,8)	6.38" (162,0)	9.6	L/H	160-2899

Rotors

UL Series Straight Vane Rotors



Ultra-Light UL straight vane rotors provide high value performance and rugged durability for a wide range of competition, high performance, and sport driving applications. Don't confuse these rotors with bargain priced off-brand named parts. ULHP rotor are manufactured using a 1:1 turning process which yields tighter tolerances for flatness, parallelism and run-out. Wilwood's modern manufacturing capability, combined with large scale economies, make it possible to offer this level of quality and performance at such an affordable price. The straight vane design also makes it possible to use the same rotor on left or right hand mounting locations.

Rotor Ordering Information

DIAMETER	WIDTH	BOLT CIRCLE	HOLE TYPE	FAR SIDE I.D.	LUG I.D.	WEIGHT LBS	ROTOR TYPE	PART NUMBER
ULHP Series								
12.19" (309,6)	1.10" (27,9)	8 x 7.00" (177,8)	.325"	8.34" (215,9)	6.38" (162,0)	13.9	ULHP-32	160-12206 ⁽¹⁾
12.19" (309,6)	.81" (20,6)	8 x 7.78" (197,6)	.251"	8.53" (216,7)	7.29" (185,2)	8.7	ULHP-32	160-6984
12.19" (309,6)	.81" (20,6)	8 x 7.78" (197,6)	.251"	8.53" (216,7)	7.29" (185,2)	8.7	ULHP-32	160-9585 ⁽¹⁾
12.19" (309,6)	.81" (20,6)	8 x 7.62" (193,6)	5/16-24	8.50" (215,9)	7.13" (181,1)	8.8	ULHP-32	160-5844
12.19" (309,6)	.81" (20,6)	8 x 7.00" (177,8)	.325"	8.50" (215,9)	6.38" (162,0)	8.9	ULHP-32	160-5843
11.75" (298,5)	.81" (20,6)	8 x 7.00" (177,8)	.325"	8.34" (211,8)	6.38" (162,0)	8.1	ULHP-32	160-5841
11.00" (279,4)	.81" (20,6)	6 x 6.25" (158,8)	.325"	7.42" (188,5)	5.59" (142,0)	7.9	ULHP-30	160-5840
11.00" (279,4)	.81" (20,6)	6 x 6.25" (158,8)	.325"	7.00" (177,8)	5.59" (142,0)	7.9	ULHP-30	160-10358 ⁽¹⁾
10.75" (273,1)	.81" (20,6)	6 x 6.25" (158,8)	.325"	7.00" (177,8)	5.59" (142,0)	7.4	ULHP-30	160-5839
UL Series								
12.19" (309,6)	1.10" (27,9)	8 x 7.00" (177,8)	.325"	8.34" (211,8)	6.38" (162,0)	13.6	UL-32	160-11862
12.19" (309,6)	.81" (20,6)	8 x 7.00" (177,8)	.325"	8.50" (215,9)	6.38" (162,0)	8.9	UL-32	160-0277
12.00" (304,8)	1.20" (30,5)	8 x 7.00" (177,8)	.325"	8.34" (211,8)	6.38" (162,0)	8.6	UL-32	160-0586
11.75" (298,5)	1.25" (31,8)	8 x 7.00" (177,8)	.325"	8.34" (211,8)	6.38" (162,0)	8.8	UL-32	160-0483
11.75" (298,5)	.81" (20,6)	10 x 6.81" (173,0)	.325"	8.00" (203,2)	6.28" (159,5)	9.1	UL-30	160-0790
11.75" (298,5)	.81" (20,6)	8 x 7.00" (177,8)	.325"	8.34" (211,8)	6.38" (162,0)	8.1	UL-32	160-0471
11.75" (298,5)	.75" (19,6)	8 x 7.62" (193,6)	5/16-24	8.50" (215,9)	7.13" (181,1)	6.9	UL-32	160-1949
10.50" (266,7)	.75" (19,6)	6 x 5.50" (139,7)	.325"	6.75" (171,5)	4.94" (125,5)	6.6	UL-30	160-3450
10.25" (260,4)	.75" (19,6)	6 x 5.50" (139,7)	.325"	6.75" (171,5)	4.94" (125,5)	6.1	UL-30	160-3747

NOTES:

(1) These rotors have a unique asymmetrical face groove pattern

ULD-32 Series Drilled Straight Vane Vented Iron Rotors

When it comes to rotors, racers are constantly searching for the ultimate balance between the lowest weight and the ability to effectively manage heat. Decreased rotating weight in the drive line provides quicker deceleration under braking and quicker acceleration out of the corners. Lower weight also benefits handling with improved spring and shock control over the unsprung suspension mass. Wilwood's ULD-32 drilled iron rotors provides effective lightweight options for sprints, late models, modifieds, and other competition applications that race in low to medium temperature ranges.



Rotor Ordering Information

DIAMETER	WIDTH	BOLT CIRCLE	HOLE TYPE	FAR SIDE I.D.	LUG I.D.	WEIGHT LBS	RH / LH	PART NUMBER
12.19" (309,6)	.81" (20,6)	8 x 7.00" (177,8)	.325"	8.50" (215,9)	6.38" (162,0)	8.0	RH / LH	160-5865
11.75" (298,5)	1.25" (31,8)	8 x 7.00" (177,8)	.325"	8.34" (211,8)	6.38" (162,0)	7.7	RH / LH	160-5864
11.75" (298,5)	.81" (20,6)	8 x 7.00" (177,8)	.325"	8.34" (211,8)	6.38" (162,0)	7.2	RH / LH	160-5863

Technical Tip

Rotor Wear

Rotors will eventually start to show signs of wear; how fast depends on the type of racing, the frequency, and the brake usage. Grooving and/or cracking due to severe heat and thermal cycling indicate the rotor should be replaced. Note that surface checking itself is not a sign a rotor needs replacing as this can occur on iron rotors. Always replace rotor mounting bolts whenever replacing rotors, taking care to inspect mounting hats or hubs for signs of wear or failure.

Rotors

ULS-32 Series Scalloped Vented Iron Rotors



ULS Series Scalloped Rotors feature a fully machined scallop configuration that provides the highest degree of weight reduction on a vented straight vane iron rotor. Scallop machining will remove as much as three pounds, or nearly 33% of the rotor mass. The vented castings provide increased cooling capacity over machined steel plate rotors, with improved structural durability over drilled rotor designs. Wilwood's ULS scalloped iron rotors provides effective lightweight options for sprints, late models, modifieds, and other competition applications that race in low to medium temperature ranges.

Rotor Ordering Information

DIAMETER	WIDTH	BOLT CIRCLE	HOLE TYPE	FAR SIDE I.D.	LUG I.D.	WEIGHT LBS	RH / LH	PART NUMBER
12.19" (309,6)	.81" (20,6)	8 x 7.00" (177,8)	.325"	8.50" (215,9)	6.38" (162,0)	5.9	RH / LH	160-8136
11.75" (298,5)	1.25" (31,8)	8 x 7.00" (177,8)	.325"	8.34" (211,8)	6.38" (162,0)	5.8	RH / LH	160-8343
11.75" (298,5)	1.25" (31,8)	8 x 7.00" (177,8)	.325"	8.75" (222,2)	6.38" (162,0)	6.7	RH / LH	160-8814
11.75" (298,5)	.81" (20,6)	8 x 7.00" (177,8)	.325"	8.34" (211,8)	6.38" (162,0)	5.4	RH / LH	160-8135
10.50" (266,7)	.75" (19,1)	6 x 5.50" (139,7)	.325"	7.30" (185,4)	4.94" (125,5)	3.8	RH / LH	160-8427

NOTES:

NOT for street use.

Super Alloy Rotors

Super Alloy vented or solid rotors are Sprint car racing's lightest. These rotors provide a cost effective, lightweight solution with quick response, long service life from the pads, and consistent braking at all temperatures. Lowered rotating weight promotes quick acceleration, deceleration, and improved handling.



Rotor Ordering Information

DIAMETER	WIDTH	BOLT CIRCLE	HOLE TYPE	FAR SIDE I.D.	LUG I.D.	WEIGHT LBS	ROTOR TYPE	PART NUMBER
12.00" (304,8)	.36" (9,1)	8 x 7.00" (177,8)	.325"	—	6.36" (161,5)	3.3	SLOTTED	160-12571 ⁽¹⁾
11.44" (290,6)	.35" (8,9)	8 x 7.00" (177,8)	.325"	—	6.38" (162,0)	5.0	DRILLED	160-12155 ⁽²⁾
11.44" (290,6)	.35" (8,9)	8 x 7.00" (177,8)	.325"	—	6.38" (162,0)	5.0	DRILLED	160-12483 ^(2,3)
10.50" (266,7)	.81" (20,6)	6 x 5.50" (139,7)	.325"	7.03" (178,6)	4.94" (125,5)	2.5	ULS-24	160-11763 ⁽¹⁾
10.50" (266,7)	.81" (20,6)	6 x 5.50" (139,7)	.325"	7.03" (178,6)	4.94" (125,5)	2.9	ULS-24	160-11217 ⁽²⁾
10.50" (266,7)	.16" (4,1)	9 x 7.00" (177,8)	.266"	7.49" (190,2)	6.25" (158,8)	1.1	SCALLOP	160-10717 ⁽²⁾

NOTES:

(1) This rotor is Titanium. • (2) This rotor is Super Alloy. • (3) Rotor has modified tab for dynamic tab mount hats.

Sprint - Open Wheel Live Axle Clamp-On Rotor Mount



Lightweight and strong, these clamps provide sturdy fixed position mounting for rear inboard brake systems on live axle sprints and modifieds.

Ordering Information

ROTOR BOLT CIRCLE	AXLE SPLINE	ROTOR MOUNT HOLE	AXLE CLAMP PART NUMBER	ROTOR BOLT KIT NUMBER	NOTES
8 x 7.00"	3.00" x 46 Spline	5/16"	270-12633	230-10484	Dynamic Mount Bolt Kit Included
6 x 5.50"	3.00" x 46 Spline	5/16"	270-12634	230-9752	Dynamic Mount Bolt Kit Included
6 X 5.50"	2.50" x 38 Spline	5/16"	270-12635	230-9752	Dynamic Mount Bolt Kit Included

Rotors

C / SiC (Carbon-Ceramic) Rotors



Wilwood's C/SiC rotors are made from a proprietary blend ceramic matrix composite material commonly known as Carbon-Ceramic. C/SiC rotors offer higher thermal conductivity and heat capacity in excess of conventional iron or titanium rotors of similar or even greater weight. Developed to withstand extreme temperatures with the highest possible degree of resistance against distortion, warping, cracking, and wear. The formulation for this composite is a derivative of technology and materials that were significant in the development of the extreme duty military spec rotors that are manufactured by Wilwood.

Rotor Ordering Information

DIAMETER	WIDTH	BOLT CIRCLE	HOLE TYPE	FAR SIDE I.D.	LUG I.D.	WEIGHT LBS	R/H L/H	PART NUMBER
14.00" (355,6)	1.25" (31,8)	12 x 8.75" (209,6)	.355"	9.49" (241,0)	7.92" (201,2)	8.2	R/L	160-12442
14.00" (355,6)	1.10" (27,9)	12 x 8.75" (209,6)	.355"	9.49" (241,0)	7.92" (201,2)	7.0	R/L	160-12441

Wilwood's OEM Replacement Racing Rotors for Modifieds

These rotors were designed utilizing the latest developments in iron formulation technology using our proprietary blend ferrous alloy to bring you the strongest, lightweight, most dependable rotor available. The rotors are new castings, not reworked parts and our tolerances are held to the highest standards. Rotors come standard with races and 5/8" coarse wheel studs installed in the 5 on 5.00" bolt pattern. The GM Metric rotor (far right) is 10.50" diameter by 1.00" thick and fits the 1978-1987 GM spindles. The Ford Hybrid version is 10.15" diameter by .81" thick rotor that fits the 1974-1980 Pinto spindles. Installation kits are available separately. Installation kits include: inner bearing, outer bearing, dust cap, spindle nut, washer, cotter pin, and seal.



Rotor Ordering Information

DIAMETER	WIDTH	STUD CIRCLE	STUD DIA.	INSTALLATION KIT PART NUMBER (1)	WEIGHT LBS	ROTOR APPLICATION	PART NUMBER
10.50" (266,7)	1.00" (25,4)	5 on 5.00" (127,0)	.625"	370-9537	14.9	GM Metric	160-9239
10.15" (257,8)	.81" (20,6)	5 on 5.00" (127,0)	.625"	370-9545	14.5	Ford Hybrid	160-9240

NOTES:

(1) Installation kit includes inner bearing, outer bearing, dust cap, spindle nut, washer, Cotter pin and seal.

Steel Rotors Overview

Steel rotors (next page) provide a durable lightweight option in applications where sustained temperatures remain in the low to moderate range, and high heat spikes are only observed on an intermittent basis. Steel rotors can be utilized in lighter weight open wheel cars such as sprints and modifieds, and a variety of light weight, open wheel road course racers. A special, and proprietary alloy - these rotors have high resistance to thermal distortion with excellent friction and wear characteristics.

Rotors

Standard Hole Mount Steel Rotors



Steel rotors provide a durable lightweight option in applications where sustained temperatures remain in the low to moderate range, and high heat spikes are only observed on an intermittent basis. A special alloy and proprietary manufacturing processes give these rotors high resistance to thermal distortion with excellent friction and wear characteristics against the pads. These rotors are most often directly mounted to "fixed" mount hats or mounting plates, but they can also be used with special dynamic slotted mount hats or plates that require the use of a standard hole mount disc. Each rotor size is available in the standard solid plate style, or weight drilled for lighter duty applications.

Rotor Ordering Information

DIAMETER	WIDTH	BOLT CIRCLE	HOLE TYPE	LUG I.D.	WEIGHT LBS	ROTOR TYPE	PART NUMBER
6 and 8 Bolt							
12.00" (304,8)	.31" (7,9)	8 x 7.62" (193,6)	5/16-24	7.00" (177,8)	5.3	SOLID	160-0490
12.00" (304,8)	.31" (7,9)	8 x 7.62" (193,6)	5/16-24	7.00" (177,8)	4.6	DRILLED	160-0495
12.00" (304,8)	.35" (8,9)	8 x 7.00" (177,8)	.325"	6.38" (162,0)	6.0	SOLID	160-0524
12.00" (304,8)	.35" (8,9)	8 x 7.00" (177,8)	.325"	6.38" (162,0)	5.4	DRILLED	160-0525
11.75" (298,5)	.35" (8,9)	8 x 7.00" (177,8)	.325"	6.38" (162,0)	5.9	SOLID	160-3201
11.75" (298,5)	.35" (8,9)	8 x 7.00" (177,8)	.325"	6.38" (162,0)	5.3	DRILLED	160-3202
11.44" (290,6)	.35" (8,9)	8 x 7.00" (177,8)	.325"	6.38" (162,0)	5.4	SOLID	160-0201
11.44" (290,6)	.35" (8,9)	8 x 7.00" (177,8)	.325"	6.38" (162,0)	4.7	DRILLED	160-1601
10.75" (273,1)	.35" (8,9)	6 x 6.25" (158,5)	.316"	5.54" (142,0)	5.2	SOLID	160-3305
10.75" (273,1)	.35" (8,9)	6 x 6.25" (158,5)	.316"	5.54" (142,0)	4.7	DRILLED	160-3306
10.50" (266,7)	.35" (8,9)	6 x 5.50" (139,7)	.325"	4.94" (125,5)	5.2	SOLID	160-10021
10.50" (266,7)	.35" (8,9)	6 x 5.50" (139,7)	.325"	4.94" (125,5)	4.7	DRILLED	160-3455
10.25" (260,4)	.35" (8,9)	6 x 5.50" (139,7)	.325"	4.94" (125,5)	4.6	DRILLED	160-3748
3 and 5 Bolt							
11.00" (279,4)	.31" (7,9)	3 x 5.00" (127,0)	.500"	4.10" (104,1)	4.6	DRILLED	160-2084
11.00" (279,4)	.31" (7,9)	3 x 5.00" (127,0)	.500"	4.10" (104,1)	3.3	DRILLED	160-10475
10.25" (260,4)	.31" (7,9)	3 x 5.00" (127,0)	.500"	4.10" (104,1)	4.1	DRILLED	160-3458
10.00" (254,0)	.32" (8,2)	5 x 3.88" (98,6)	.391"	3.12" (79,2)	5.2	SOLID	160-2181
10.00" (254,0)	.32" (8,2)	5 x 3.88" (98,6)	.391"	3.12" (79,2)	4.8	DRILLED	160-2182
10.00" (254,0)	.25" (6,4)	5 x 5.00" (127,0)	.391"	4.10" (104,1)	3.6	SOLID	160-0867
10.00" (254,0)	.25" (6,4)	5 x 5.00" (127,0)	.391"	4.10" (104,1)	3.2	DRILLED	160-1602

NOTES:

(1) This rotor is Polymetallic coated

Dynamic Mount Drilled Steel Rotors

Dynamic mounting is the most effective method of eliminating all types of thermal stress and distortion in steel rotor applications. These rotors are machined with mounting slots that are used with special t-nuts and bolt kits. This mounting system allows the rotor to expand and contract independently of the mounting hat or hub as the rotor goes through temperature changes. This eliminates all strain or bind at the mounting points. The rotors run truer, last longer, and all undo stress on the hats or hubs is eliminated. Dynamic mounting is preferred in all applications where temporary, but extreme temperature spikes may cause high expansion rates in the steel. Wilwood also offers slotted dynamic mount hats and plates that are used to provide "float" with a standard hole mount rotor, but the rotors in this category are machined for use on "fixed" mounts that require the "float" to be placed within the rotor itself.



Rotor Ordering Information

DIAMETER	WIDTH	BOLT CIRCLE	HOLE TYPE	LUG I.D.	BOLT KIT	WEIGHT LBS	ROTOR TYPE	PART NUMBER
12.90" (327,7)	.38" (9,7)	12 x 8.75" (222,3)	SLOT	8.25" (209,6)	230-4900	5.7	sSP	160-4766
12.19" (309,6)	.35" (8,9)	8 x 7.00" (177,8)	.325"	6.38" (162,1)	(1, 2)	4.5	sCALLOP	160-9773
12.19" (309,6)	.35" (8,9)	8 x 7.00" (177,8)	SLOT	6.56" (166,6)	(1, 2)	4.8	sCALLOP	160-5538
11.75" (298,5)	.35" (8,9)	8 x 7.00" (177,8)	.325"	6.38" (162,1)	(1, 2)	4.1	sCALLOP	160-9772
11.75" (298,5)	.35" (8,9)	8 x 7.00" (177,8)	SLOT	6.56" (166,6)	(1, 2)	4.5	sCALLOP	160-5855

NOTES:

(1) To mount this rotor on a 5/16-18 threaded hat or hub, use bolt and t-nut kit 230-5308.
 (2) To mount this rotor on a sprint car or open wheel axle mount clamp, use bolt kit and t-nut kit 230-5567.

Rotors

WARNING: SPECIAL RACING APPLICATION ONLY

ALUMINUM ROTORS ARE **UNSAFE** FOR STREET USE • ALUMINUM ROTORS ARE NOT SUITABLE FOR MOST FORMS OF RACING AND CAN RESULT IN CATASTROPHIC FAILURE WHEN MISUSED

READ DISCLAIMER OF WARRANTY LOCATED ON THE INSIDE BACK COVER OF THE CATALOG

Aluminum Sprint / Midget Rotors

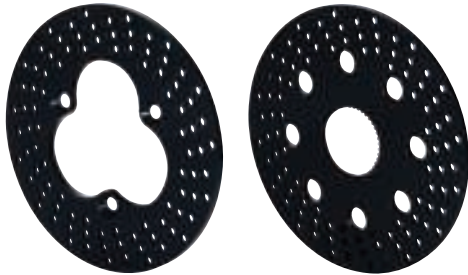

Full symmetrical machining provides perfect balance, perfect flatness and the truest rotation of any aluminum rotor being built. Wilwood's engineered drill and relief slot pattern combines the highest degree of weight reduction with the highest resistance to thermal distortion in the contact faces. You get smooth engagement and a consistent full pedal from the low knock-back characteristics of this design. A durable black anodized finish prevents corrosion and simplifies the visual inspection of the contact faces. The best results are always achieved using PolyMatrix Q compound brake pads with these rotors.

Rotor Ordering Information

DIAMETER	WIDTH	BOLT CIRCLE	HOLE TYPE	WEIGHT LBS	ROTOR TYPE	PART NUMBER
3 Hole Mount						
10.95" (278,1)	.31" (7,9)	3 x 5.00" (127,0)	.516"	1.8	DRILLED	160-3327
10.20" (259,1)	.31" (7,9)	3 x 5.00" (127,0)	.516"	1.6	DRILLED	160-3411
Splined Axle Mount						
10.95" (278,1)	.31" (7,9)	3 x 42 SPLINE	—	2.3	DRILLED	160-3275
10.20" (259,1)	.31" (7,9)	3 x 42 SPLINE	—	1.9	DRILLED	160-3270

NOTES:

Technical Tip

Rotor Bedding

All new iron rotors should be bedded-in before being used under racing conditions. Proper bedding-in will prepare the rotor surface, prolong the rotor's life and make it more resistant to thermal checking or cracking under severe braking conditions. The following procedures should be followed when bedding-in rotors:

- Thoroughly inspect all brake system components before proceeding to track. Check all bolt connections, make sure mounting bolts and rotor bolts are properly lockwired, that brake pads are properly secured by retaining clips or cotter pins, that master cylinders and brake pedals are working properly, that brakes are properly bled with plenty of fluid, and that proper engagement of brakes occur when pedal is depressed.
- Because the bedding process is different for rotors and pads, it is best to bed-in a new rotor (disc) using a used set of pads, preferably ones which will not create heat rapidly. Generating heat too quickly will thermal shock the rotors. Likewise, when bedding-in a new set of brake pads, use a used rotor. This new-used bedding process permits controlled bedding of each individual component.
- Make sure that the rotor surfaces are free from oils, grease and brake fluid.
- Close air ducts approximately 75% to expedite the bedding-in process.
- Run vehicle up to moderate speed and make several medium deceleration stops to heat up the rotor slowly. This will help reduce the chance of thermal shock caused by un-even heating of the rotor.
- Pull into the pits and allow the rotor to cool to ambient air temperature.
- Do not hold brakes on after performing the bedding-in procedure until cooling is completed. This will avoid "hot spotting" or un-even cooling which can damage the rotor.

Rotors

SRP Drilled and Slotted Performance Rotors



SRP Drilled Performance Rotors feature a specially engineered directional cross drill and face slot pattern that improves brake response and pad performance throughout the entire range of light to heavy braking. The venting and cleaning action of the holes and slots will reduce pad glaze and disperse gasses and heat generated during the pad to rotor interface. The holes and slots also inhibit irregular pad compound build-up on the rotor faces resulting in smoother engagement and improved pedal response in all conditions. The material removed also contributes to lower rotating mass and unsprung suspension weight. Rotors are treated with a black electro coat to inhibit corrosion on all areas of the rotor, including the interior vanes to which other coatings like zinc, won't adhere.

Rotor Ordering Information

DIAMETER	WIDTH	BOLT CIRCLE	HOLE TYPE	FAR SIDE I.D.	LUG I.D.	WEIGHT LBS	RH LH	PART NUMBER
16.00" (406.4)	1.38" (35.1)	12 x 10.75" (273.1)	.315"	11.76" (298.7)	10.00" (254.0)	22.4	R/H	160-8955-BK
16.00" (406.4)	1.38" (35.1)	12 x 10.75" (273.1)	.315"	11.76" (298.7)	10.00" (254.0)	22.4	L/H	160-8956-BK
15.00 (381.0)	1.25" (31.8)	12 x 8.75" (222.2)	.251"	10.67" (271.0)	8.25" (209.6)	15.2	R/H	160-11756-BK
15.00 (381.0)	1.25" (31.8)	12 x 8.75" (222.2)	.251"	10.67" (271.0)	8.25" (209.6)	15.2	L/H	160-11757-BK
14.25" (362.0)	1.25" (31.8)	12 x 9.19" (233.4)	.251"	10.00" (254.0)	8.63" (219.2)	18.7	R/H	160-9762-BK
14.25" (362.0)	1.25" (31.8)	12 x 9.19" (233.4)	.251"	10.00" (254.0)	8.63" (219.2)	18.7	L/H	160-9763-BK
14.25" (362.0)	1.25" (31.8)	12 x 8.75" (222.2)	.251"	10.00" (254.0)	8.25" (209.6)	18.8	R/H	160-11313-BK
14.25" (362.0)	1.25" (31.8)	12 x 8.75" (222.2)	.251"	10.00" (254.0)	8.25" (209.6)	18.8	L/H	160-11314-BK
14.25" (362.0)	1.10" (27.9)	12 x 8.75" (222.2)	.251"	10.00" (254.0)	8.25" (209.6)	15.8	R/H	160-11309-BK
14.25" (362.0)	1.10" (27.9)	12 x 8.75" (222.2)	.251"	10.00" (254.0)	8.25" (209.6)	15.8	L/H	160-11310-BK
14.00" (355.6)	1.25" (31.8)	12 x 8.75" (222.2)	.251"	10.00" (254.0)	8.25" (209.6)	17.4	R/H	160-8396-BK
14.00" (355.6)	1.25" (31.8)	12 x 8.75" (222.2)	.251"	10.00" (254.0)	8.25" (209.6)	17.4	L/H	160-8397-BK
14.00" (355.6)	1.25" (31.8)	12 x 8.75" (222.2)	.251"	9.01" (228.9)	7.75" (196.9)	21.6	R/H	160-12341-BK
14.00" (355.6)	1.25" (31.8)	12 x 8.75" (222.2)	.251"	9.01" (228.9)	7.75" (196.9)	21.6	L/H	160-12342-BK
14.00" (355.6)	1.10" (27.9)	12 x 8.75" (222.2)	.251"	10.00" (254.0)	8.25" (209.6)	14.5	R/H	160-8400-BK ⁽¹⁾
14.00" (355.6)	1.10" (27.9)	12 x 8.75" (222.2)	.251"	10.00" (254.0)	8.25" (209.6)	14.5	L/H	160-8401-BK ⁽¹⁾
13.06" (331.7)	1.25" (31.8)	12 x 8.75" (222.2)	.251"	9.46" (240.3)	8.25" (209.6)	12.3	R/H	160-7798-BK^(1,4)
13.06" (331.7)	1.25" (31.8)	12 x 8.75" (222.2)	.251"	9.46" (240.3)	8.25" (209.6)	12.3	L/H	160-7799-BK^(1,4)
13.00" (330.2)	1.10" (27.9)	12 x 7.00" (177.8)	.251"	8.57" (217.7)	6.38" (162.0)	14.4	R/H	160-8510-BK
13.00" (330.2)	1.10" (27.9)	12 x 7.00" (177.8)	.251"	8.57" (217.7)	6.38" (162.0)	14.4	L/H	160-8511-BK
12.90" (327.7)	1.25" (31.8)	12 x 8.75" (222.2)	.251"	9.46" (240.3)	8.25" (209.6)	11.5	R/H	160-7172-BK^(1,4)
12.90" (327.7)	1.25" (31.8)	12 x 8.75" (222.2)	.251"	9.46" (240.3)	8.25" (209.6)	11.5	L/H	160-7173-BK^(1,4)
12.90" (327.7)	1.10" (27.9)	12 x 8.75" (222.2)	.251"	9.46" (240.3)	8.25" (209.6)	11.9	R/H	160-6835-BK ⁽¹⁾
12.90" (327.7)	1.10" (27.9)	12 x 8.75" (222.2)	.251"	9.46" (240.3)	8.25" (209.6)	11.9	L/H	160-6836-BK ⁽¹⁾
12.90" (327.7)	1.00" (25.4)	12 x 8.75" (222.2)	.251"	9.46" (240.3)	8.25" (209.6)	10.4	R/H	160-8006-BK ⁽¹⁾
12.90" (327.7)	1.00" (25.4)	12 x 8.75" (222.2)	.251"	9.46" (240.3)	8.25" (209.6)	10.4	L/H	160-8007-BK ⁽¹⁾
12.90" (327.7)	.81" (20.6)	12 x 8.75" (222.2)	.251"	9.46" (240.3)	8.25" (209.6)	10.1	R/H	160-9961-BK
12.90" (327.7)	.81" (20.6)	12 x 8.75" (222.2)	.251"	9.46" (240.3)	8.25" (209.6)	10.1	L/H	160-9962-BK
12.88" (327.2)	.75" (19.1)	12 x 8.75" (222.2)	.251"	9.46" (240.3)	8.25" (209.6)	10.1	R/H	160-12469-BK
12.88" (327.2)	.75" (19.1)	12 x 8.75" (222.2)	.251"	9.46" (240.3)	8.25" (209.6)	10.1	L/H	160-12470-BK
12.80" (325.1)	1.25" (31.8)	12 x 7.06" (179.3)	.251"	8.41" (213.6)	6.53" (165.9)	14.5	R/H	160-7744-BK⁽⁴⁾
12.80" (325.1)	1.25" (31.8)	12 x 7.06" (179.3)	.251"	8.41" (213.6)	6.53" (165.9)	14.5	L/H	160-7745-BK⁽⁴⁾
12.44" (316.0)	1.19" (30.2)	12 x 7.00" (177.8)	.251"	7.87" (202.3)	6.55" (166.4)	12.1	R/H	160-12157-BK⁽⁴⁾
12.44" (316.0)	1.19" (30.2)	12 x 7.00" (177.8)	.251"	7.87" (202.3)	6.55" (166.4)	12.1	L/H	160-12158-BK⁽⁴⁾
12.19" (309.6)	1.10" (27.9)	8 x 7.00" (177.8)	.325"	8.34" (215.9)	6.38" (162.0)	13.4	R/H	160-12204-BK
12.19" (309.6)	1.10" (27.9)	8 x 7.00" (177.8)	.325"	8.34" (215.9)	6.38" (162.0)	13.4	L/H	160-12205-BK
12.19" (309.6)	.81" (20.6)	8 x 7.78" (197.6)	.251"	8.53" (216.7)	7.29" (185.2)	8.6	R/H	160-6924-BK
12.19" (309.6)	.81" (20.6)	8 x 7.78" (197.6)	.251"	8.53" (216.7)	7.29" (185.2)	8.6	L/H	160-6925-BK
12.19" (309.6)	.81" (20.6)	8 x 7.62" (193.6)	5/16-24	8.50" (215.9)	7.13" (181.1)	8.6	R/H	160-7105-BK ⁽¹⁾
12.19" (309.6)	.81" (20.6)	8 x 7.62" (193.6)	5/16-24	8.50" (215.9)	7.13" (181.1)	8.6	L/H	160-7106-BK ⁽¹⁾
12.19" (309.6)	.81" (20.6)	8 x 7.00" (177.8)	.325"	8.50" (215.9)	6.38" (162.0)	8.8	R/H	160-7103-BK ⁽¹⁾
12.19" (309.6)	.81" (20.6)	8 x 7.00" (177.8)	.325"	8.50" (215.9)	6.38" (162.0)	8.8	L/H	160-7104-BK ⁽¹⁾
12.00" (304.8)	.81" (20.6)	8 x 7.00" (177.8)	.325"	8.41" (213.6)	6.38" (162.0)	8.3	R/H	160-8496-BK
12.00" (304.8)	.81" (20.6)	8 x 7.00" (177.8)	.325"	8.41" (213.6)	6.38" (162.0)	8.3	L/H	160-8497-BK
11.75" (298.5)	1.25" (31.8)	5 on 4.75" (120.7)	-	7.06" (179.3)	-	19.0	R/H	160-11285-BK ⁽²⁾
11.75" (298.5)	1.25" (31.8)	5 on 4.75" (120.7)	-	7.06" (179.3)	-	19.0	L/H	160-11286-BK ⁽²⁾
11.75" (298.5)	1.25" (31.8)	5 on 4.75" (120.7)	-	7.06" (179.3)	-	17.2	R/H	160-11287-BK ⁽³⁾
11.75" (298.5)	1.25" (31.8)	5 on 4.75" (120.7)	-	7.06" (179.3)	-	17.2	L/H	160-11288-BK ⁽³⁾
11.75" (298.5)	.81" (20.6)	8 x 7.00" (177.8)	.325"	8.34" (211.9)	6.38" (162.0)	8.0	R/H	160-7101-BK
11.75" (298.5)	.81" (20.6)	8 x 7.00" (177.8)	.325"	8.34" (211.9)	6.38" (162.0)	8.0	L/H	160-7102-BK
11.00" (279.4)	.81" (20.6)	6 x 6.25" (158.8)	.325"	7.00" (177.8)	5.59" (142.0)	7.7	R/H	160-7099-BK ⁽¹⁾
11.00" (279.4)	.81" (20.6)	6 x 6.25" (158.8)	.325"	7.00" (177.8)	5.59" (142.0)	7.7	L/H	160-7100-BK ⁽¹⁾
10.75" (273.1)	.81" (20.6)	6 x 6.25" (158.8)	.325"	7.00" (177.8)	5.59" (142.0)	7.2	R/H	160-7097-BK
10.75" (273.1)	.81" (20.6)	6 x 6.25" (158.8)	.325"	7.00" (177.8)	5.59" (142.0)	7.2	L/H	160-7098-BK
10.50" (266.7)	.75" (19.6)	6 x 5.50" (139.7)	.325"	6.75" (171.5)	4.94" (125.5)	6.4	R/H	160-9249
10.50" (266.7)	.75" (19.6)	6 x 5.50" (139.7)	.325"	6.75" (171.5)	4.94" (125.5)	6.4	L/H	160-9250

NOTES: (1) These rotors are also available zinc coated. Remove -BK from end of part number when ordering.
 (2) These are one piece hat/rotor combination rotors utilized as OEM replacements for front C-2, C-3 Chevrolet Corvette.
 (3) These are one piece hat/rotor combination rotors utilized as OEM replacements for rear C-2, C-3 Chevrolet Corvette.
 (4) **Bold** text denotes Spec 37 rotor material. Please check our website for more information on Spec 37 rotors and configurations.

Rotors

SRP Disc / Drum Rotors for Internal Parking Brakes

For custom, show, and high performance sport driving, SRP rotors offer the high tech look and improved performance of a directional cross-drill and face slot pattern. In addition to the aesthetic appeal, the venting and cleaning action of the hole and slot pattern helps to reduce pad glaze and minimize irregular pad build-up on the rotor faces. The results are a smoother engagement feel at the pedal and consistent response from the pads. Each rotor is precision machined to less than .001" tolerance for overall flatness, parallelism, and radial run-out on long grain carbon iron castings. The rotors are finished with a black electro coat (some are available with a zinc coating) to provide corrosion resistance.



Rotor Ordering Information

DIAMETER	WIDTH	LUG PATTERN	STUD HOLE	OFFSET	SHOE I.D.	FACE THICKNESS	CENTER HOLE	R/H L/H	PART NUMBER
12.27" (311,7)	.78" (19,8)	5 on 4.75"	.58"	2.08"	7.08"	.34"	2.96"	R/H	160-8685-BK
12.27" (311,7)	.78" (19,8)	5 on 4.75"	.58"	2.08"	7.08"	.34"	2.96"	L/H	160-8686-BK
12.19" (309,6)	.81" (20,6)	5 on 4.75"	.45/.48/.52"	2.32	7.24	.18"	3.06" (2)	R/H	160-10050-BK
12.19" (309,6)	.81" (20,6)	5 on 4.75"	.45/.48/.52"	2.32	7.24	.18"	3.06" (2)	L/H	160-10051-BK
12.19" (309,6)	.81" (20,6)	5 on 4.50/4.75/5.00"	.52"	2.32"	7.24"	.18"	3.06" (2)	R/H	160-9814-BK ⁽¹⁾
12.19" (309,6)	.81" (20,6)	5 on 4.50/4.75/5.00"	.52"	2.32"	7.24"	.18"	3.06" (2)	L/H	160-9815-BK ⁽¹⁾
12.19" (309,6)	.81" (20,6)	5 on 4.50/4.75/5.00"	.52"	1.91"	7.24"	.18"	3.12"	R/H	160-9989-BK
12.19" (309,6)	.81" (20,6)	5 on 4.50/4.75/5.00"	.52"	1.91"	7.24"	.18"	3.12"	L/H	160-9990-BK
12.19" (309,6)	.81" (20,6)	5 on 4.50/4.75/5.00"	.52"	1.91"	7.24"	.18"	3.06" (2)	R/H	160-9812-BK ⁽¹⁾
12.19" (309,6)	.81" (20,6)	5 on 4.50/4.75/5.00"	.52"	1.91"	7.24"	.18"	3.06" (2)	L/H	160-9813-BK ⁽¹⁾
12.19" (309,6)	.81" (20,6)	5 on 4.75"	.52"	2.31"	7.48"	.21"	2.80"	R/H	160-8744-BK
12.19" (309,6)	.81" (20,6)	5 on 4.75"	.52"	2.31"	7.48"	.21"	2.80"	L/H	160-8745-BK
12.19" (309,6)	.81" (20,6)	Undrilled	—	1.91"	7.24"	.18"	3.06" (2)	R/H	160-6972-BK
12.19" (309,6)	.81" (20,6)	Undrilled	—	1.91"	7.24"	.18"	3.06" (2)	L/H	160-6973-BK
12.00" (304,8)	1.03" (26,2)	5 on 4.75"	.53"	.64"	7.48"	.26"	2.80"	R/H	160-7767-BK
12.00" (304,8)	1.03" (26,2)	5 on 4.75"	.53"	.64"	7.48"	.26"	2.80"	L/H	160-7768-BK
11.00" (279,4)	.81" (20,6)	5 on 4.50/4.75/5.00"	.52"	2.32"	7.24"	.18"	3.06" (2)	R/H	160-11376-BK
11.00" (279,4)	.81" (20,6)	5 on 4.50/4.75/5.00"	.52"	2.32"	7.24"	.18"	3.06" (2)	L/H	160-11377-BK
11.00" (279,4)	.81" (20,6)	5 on 4.50/4.75/5.00"	.52"	1.91"	7.24"	.18"	3.06" (2)	R/H	160-11374-BK ⁽¹⁾
11.00" (279,4)	.81" (20,6)	5 on 4.50/4.75/5.00"	.52"	1.91"	7.24"	.18"	3.06" (2)	L/H	160-11375-BK ⁽¹⁾
11.00" (279,4)	.81" (20,6)	5 on 4.50/4.75/5.00"	.52"	1.75"	6.88"	.19"	2.80"	R/H	160-10327-BK
11.00" (279,4)	.81" (20,6)	5 on 4.50/4.75/5.00"	.52"	1.75"	6.88"	.19"	2.80"	L/H	160-10328-BK
11.00" (279,4)	.81" (20,6)	5 on 4.50/4.75/5.00"	.52"	1.91"	7.24"	.18"	3.12"	R/H	160-11521-BK
11.00" (279,4)	.81" (20,6)	5 on 4.50/4.75/5.00"	.52"	1.91"	7.24"	.18"	3.12"	L/H	160-11522-BK
11.00" (279,4)	.81" (20,6)	4 on 4.50"	.61"	2.32"	7.24"	.18"	3.06" (2)	R/H	160-12754-BK
11.00" (279,4)	.81" (20,6)	4 on 4.50"	.61"	2.32"	7.24"	.18"	3.06" (2)	L/H	160-12755-BK
11.00" (279,4)	.81" (20,6)	Undrilled	—	1.91"	7.24"	.18"	3.06" (2)	R/H	160-11552-BK
11.00" (279,4)	.81" (20,6)	Undrilled	—	1.91"	7.24"	.18"	3.06" (2)	L/H	160-11553-BK

NOTES:

- (1) These rotors are also available zinc coated. Remove -BK from end of part number when ordering.
- (2) These rotors with 3.06" registers have an additional relief for rotor registration adapters. See listings on page 42.

GT Disc / Drum Rotors for Internal Parking Brakes



GT rotors feature Wilwood's ultimate competition preparation with full detail machining, asymmetrical face slotting, and individual dynamic balancing. Full detail machining eliminates unnecessary weight and potential stress points. The venting and cleaning action of the asymmetrical face slot pattern helps to reduce pad glaze, minimize irregular pad build-up on the rotor faces, and interrupt engagement harmonics.

GT rotors run smooth, true, and vibration free at all speeds with the highest levels of performance in sustained high heat conditions.

Rotor Ordering Information

DIAMETER	WIDTH	LUG PATTERN	STUD HOLE	OFFSET	SHOE I.D.	FACE THICKNESS	CENTER HOLE	R/H L/H	PART NUMBER
12.27" (311,7)	.78" (19,8)	5 on 4.75"	.58"	2.08"	7.08"	.34"	2.96"	R/H	160-8683
12.27" (311,7)	.78" (19,8)	5 on 4.75"	.58"	2.08"	7.08"	.34"	2.96"	L/H	160-8684
12.19" (309,6)	.81" (20,6)	5 on 4.75"	.52"	2.31"	7.48"	.21"	2.76"	R/L	160-8743
12.19" (309,6)	.81" (20,6)	5 on 4.50/4.75/5.00"	.52"	2.32"	7.24"	.18"	3.06" (1)	R/L	160-12151
12.19" (309,6)	.81" (20,6)	5 on 4.50/4.75/5.00"	.52"	1.91"	7.24"	.18"	3.06" (1)	R/L	160-12150

NOTES:

- (1) These rotors with 3.06" registers have an additional relief for rotor registration adapters. See listings on page 42.

Rotors

HP Disc / Drum Rotors for Internal Parking Brakes

HP rotors are close tolerance machined with smooth turned pad faces. The additional mass of the HP series extends service life on heavier competition vehicles and other severe duty applications. They are also the base model for every day use.

Each rotor is precision machined to less than .001" tolerance for overall flatness, parallelism, and radial run-out on long grain carbon iron castings. Long grain carbon iron is used for its superior thermal conductivity and stability properties that resist distortion and fatigue.



Rotor Ordering Information

DIAMETER	WIDTH	LUG PATTERN	STUD HOLE	OFFSET	SHOE I.D.	FACE THICKNESS	CENTER HOLE	R/H L/H	PART NUMBER
12.19" (309,6)	.81" (20,6)	5 on 4.50/4.75/5.00"	.52"	2.32"	7.24"	.18"	3.06" (1)	R/L	160-9986
12.19" (309,6)	.81" (20,6)	5 on 4.50/4.75/5.00"	.52"	1.91"	7.24"	.18"	3.12"	R/L	160-9987
12.19" (309,6)	.81" (20,6)	5 on 4.50/4.75/5.00"	.52"	1.91"	7.24"	.18"	3.06" (1)	R/L	160-7508
12.19" (309,6)	.81" (20,6)	5 on 4.75"	.45/.48/.52"	2.32"	7.24"	.18"	3.06" (1)	R/L	160-10049
12.19" (309,6)	.81" (20,6)	Undrilled	—	2.32"	7.24"	.18"	3.06" (1)	R/L	160-8865
12.19" (309,6)	.81" (20,6)	Undrilled	—	1.91"	7.24"	.18"	3.06" (1)	R/L	160-6868
11.00" (279,4)	.81" (20,6)	5 on 4.50/4.75/5.00"	.52"	2.32"	7.24"	.20"	3.06" (1)	R/L	160-11365
11.00" (279,4-)	.81" (20,6)	5 on 4.50/4.75/5.00"	.52"	1.91"	7.24"	.18"	3.12"	R/L	160-11520
11.00" (279,4)	.81" (20,6)	5 on 4.50/4.75/5.00"	.52"	1.91"	7.24"	.18"	3.06" (1)	R/L	160-11519
11.00" (279,4)	.81" (20,6)	5 on 4.50/4.75/5.00"	.52"	1.91"	7.24"	.20"	3.06" (1)	R/L	160-11364
11.00" (279,4)	.81" (20,6)	5 on 4.50/4.75/5.00"	.52"	1.75"	6.88"	.19"	2.80"	R/L	160-10326
11.00" (279,4)	.81" (20,6)	4 on 4.50"	.61"	2.32"	7.24"	.18"	3.06" (1)	R/L	160-12594

NOTES:

(1) These rotors with 3.06" registers have an additional relief for rotor registration adapters. See listings on page 42.

Challenge Series Rotors



Purpose built one-piece carbon iron rotors make the Challenge Series rotors Wilwood's most affordable option to install real big brake stopping power and performance on popular OE muscle car and aftermarket spindles. Available in GT or SRP rotor options. GT competition series rotors feature full detail machining with asymmetrical pad cleaning slots in the faces. GT rotors provide the highest degree of durability for repeated hard braking and high temperature use on dedicated track cars, or dual purpose street and track vehicles that will compete at a high level. SRP performance rotors feature our directional drill and slot pattern with a durable E-Coat finish to keep their high-tech styling looking their best over many miles. SRP rotors provide consistent stopping power and long service life, with the toughness for those occasional days at the track.

Rotor Ordering Information

DIAMETER	WIDTH	LUG PATTERN	STUD HOLE	OFFSET	SHOE I.D.	FACE THICKNESS	CENTER HOLE	R/H L/H	PART NUMBER
GT Style									
12.88" (327,2)	1.10" (27,9)	5 on 4.50/4.75	.52"	1.75"	6.50"	.24"	3.06" (1)	L/R	160-12191
SRP Style									
13.22" (335,8)	1.17" (29,7)	5 on 4.50"	.59"	.40"	6.30"	.31"	2.80"	R/H	160-12722-BK
13.22" (335,8)	1.17" (29,7)	5 on 4.50"	.59"	.40"	6.30"	.31"	2.80"	L/H	160-12723-BK
12.88" (327,2)	1.10" (27,9)	5 on 4.50/4.75"	.52"	1.75"	6.50"	.25"	3.06" (1)	R/H	160-12189-BK
12.88" (327,2)	1.10" (27,9)	5 on 4.50/4.75"	.52"	1.75"	6.50"	.25"	3.06" (1)	L/H	160-12190-BK
11.88" (301,8)	.76" (19,3)	5 on 4.50"	.58"	.33"	6.25"	.30"	2.78"	R/H	160-12170-BK
11.88" (301,8)	.76" (19,3)	5 on 4.50"	.58"	.33"	6.25"	.30"	2.78"	L/H	160-12171-BK

NOTES:

(1) These rotors with 3.06" registers have an additional relief for rotor registration adapters. See listings on page 42.

Rotor Plates

Dynamic Rotor Mounting Systems

The Wilwood system places the "float" within the hat or plate, and then allows the use of standard through-hole mount rotors. The ability to use through-hole mount rotors provides increased durability, improved accuracy, and a wider variety of selections over slotted mount hole rotor designs. Wilwood's square faced t-nuts provide a substantially wider load-bearing surface as compared to the round pin and bobbin type mounts. Each rotor bolt and t-nut kit includes an installation tool that correctly positions the t-nut during the assembly process. This assures bind-free operation right from the start. The results are felt with truer running, smoother engagement, extended reliability, and consistent pedal feel after every lap.



Dynamic Mount Rotor Plates For 5 x 5 Hubs



These "dynamic" mount plates replace the "fixed" mount plates used on 5 x 5.00" lug pattern racing hubs designed for integral backside rotor mounting. Each plate is precision machined from premium alloy aluminum offering high strength with low rotating and unsprung weight. The rotor bolt and t-nut kits allow "float" mounting of any standard 5/16" hole rotor with an 8 on 7.00" bolt circle.

Rotor Plate Ordering Information

ROTOR BOLT CIRCLE	HUB MOUNTING BOLT PATTERN	PLATE OFFSET	HUB MOUNT HOLE I.D.	PLATE LUG I.D.	PLATE O.D.	PLATE THICKNESS	ROTOR MOUNT	PLATE PART NUMBER	BOLT & T-NUT KIT NUMBER
8 x 7.00"	5 x 4.88"	0"	.39"	4.26"	7.50"	.31"	T-SLOT	300-7107	230-6710

Dynamic Mount Rotor Plates For Wide 5 Hubs

These plates attach directly to the rotor mount bosses on wide 5 hubs and use the t-nut rotor bolt kits (shown far right) to "float" mount any standard 5/16" hole rotor with an 8 on 7" bolt circle. Use of these plates requires hubs that have been specially machined to compensate for the plate thickness to maintain the original rotor position. Starlite, Starlite "55" and Starlite 55-XD hubs can be found on pages 45-47.



Rotor Plate Ordering Information

ROTOR BOLT CIRCLE	HUB MOUNTING BOLT PATTERN	PLATE OFFSET	HUB MOUNT HOLE I.D.	PLATE LUG I.D.	PLATE O.D.	PLATE THICKNESS	ROTOR MOUNT	PLATE PART NUMBER	BOLT & T-NUT KIT NUMBER
8 x 7.00"	8 x 7.00"	0"	.32"	5.50"	7.60"	.24"	T-SLOT	300-8431	230-8454

Hat Measurements

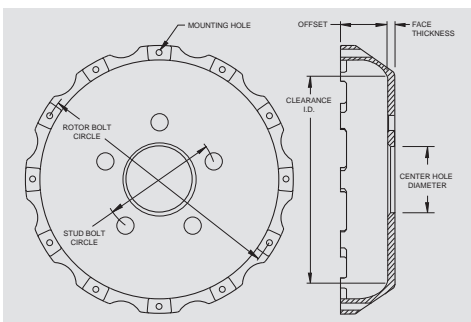

The diagram at the right depicts a typical Wilwood hat dimensional attributes. Reference this drawing in conjunction with the ordering information tables within this section to select the proper hat configuration for your needs.

Rotor Hats

GT Series Dynamic Mount Rotor Hats



Hats are precision machined from premium grade aluminum offering high strength with low unsprung and rotating weight. Wilwood t-nuts or bobbin float within the hat and provide true dynamic mounting of a standard through-hole mount rotor. The wide load bearing surface of the t-nut/bobbin and the standard through-hole mount rotors provide the most durable and accurate method of isolating potential pad engagement harmonics and the in-service thermal variations that occur between the hat and the rotor. Hats are available in a variety of configurations for use with racing hubs, flanged axles, and several OE applications. Straight bell hats are used for the 7.00" rotor mount pattern. Hats for the larger diameter rotor mount patterns will be the flared bell design. Hats are finished in black E-coat unless otherwise noted.

GT Dynamic Mount Hat Ordering Information

ROTOR BOLT CIRCLE	WHEEL LUG PATTERN	HAT OFFSET	STUD HOLE DIAMETER	CENTER HOLE I.D.	FACE THICKNESS	CLEARANCE I.D.	MOUNT HOLE	HAT PART NUMBER	BOLT & T-NUT KIT NUMBER	NOTES
12 x 8.75"	5 x 4.50/4.75/5.00"	1.54"	.52"	3.06"	.18"	6.85"	BOBBIN	170-12647	230-12759	(2, 3, 4)
12 x 8.75"	5 x 4.50/4.75/5.00"	1.95"	.52"	3.06"	.18"	6.85"	BOBBIN	170-12625	230-12759	(2, 3, 4)
12 x 8.75"	5 x 4.50/4.75"	0.87"	.52"	2.80"	.30"	7.25"	BOBBIN	170-12634	230-12759	(2)
12 x 8.75"	5 x 4.75"	0.29"	.52"	2.78"	.26"	7.72"	T-SLOT	170-11740	230-6656	(1)
8 x 7.00"	5 x 4.50/4.75/5.00"	1.41"	.52"	3.06"	.25"	6.20"	LUG	170-12430	300-12561	(4, 5)
8 x 7.00"	5 x 4.50/4.75/5.00"	1.59"	.52"	3.06"	.25"	6.20"	LUG	170-12426	300-12561	(4, 5)
8 x 7.00"	5 x 4.50/4.75/5.00"	1.64"	.52"	3.06"	.25"	6.20"	LUG	170-12544	300-12561	(4, 5)
8 x 7.00"	5 x 4.50/4.75/5.00"	1.71"	.52"	3.06"	.25"	6.20"	LUG	170-12427	300-12561	(4, 5)
8 x 7.00"	5 x 4.50/4.75/5.00"	1.96"	.52"	3.06"	.25"	6.20"	LUG	170-12429	300-12561	(4, 5)
8 x 7.00"	5 x 4.50/4.75"	1.96"	.70"	3.06"	.25"	6.20"	LUG	170-12431	300-12561	(4, 5)
8 x 7.00"	5 x 5.00"	2.12"	.64"	3.06"	.25"	6.64"	T-SLOT	170-6581	230-6710	(1)

- NOTES:** (1) This hat is drilled and countersunk to accommodate hat to hub anchoring screws. Screw kit P/N 230-2482 contains five (5) grade 8 1/4-28 x 1.00" countersunk flat head hex drive screws and should be ordered in addition to the hat.
 (2) Uses Wilwood's own bobbin mounting system.
 (3) This hat is iron for internal parking brake.
 (4) 3.06" diameter register with counterbore for register ring.
 (5) Uses Lug Drive rotor mounting system.

GT Series Fixed Mount Hats

Hats are precision machined from premium aluminum alloy for high strength and minimized weight. Hats in this category feature threaded rotor mount holes for use with standard through-hole mount rotors. Threaded hole hats may also be used with t-nuts or bobbins designed for use with specially machined slotted hole dynamic mount rotors. When used in conjunction with matched Wilwood rotor hardware kits, GT hats provide solid, reliable performance in the most demanding conditions. Finished in black E-coat unless otherwise noted. Hats are available in a variety of configurations as outlined below.

GT Shallow Offset / Straight Bell Hats

Shallow offset hats (near right) are for narrow space applications with offsets often less than 1.00". They are available for most rotor bolt patterns in a variety of four and five lug wheel patterns.

Straight bell hats (far right) are most often used with 11.75" to 13.00" diameter rotors with 7.00" rotor mount bolt circle rotor on stock car front hubs and rear axles. Part numbers and dimensional ordering information is available on pages 39 and 40.



GT Flared Bell / Truck Hats



Flared bell hats (far left) are generally used with rotor mount bolt circles of 8.38" and larger. Offsets range from 1.88" to 3.00" for rotor diameters 12.19" and up.

Truck hats (near left) feature strengthening ribs on a flared bell configuration for big rotor brake kits on truck, SUV, and 4WD axles with either 6 or 8 lug configurations. Part numbers and dimensional ordering information is available on pages 39 and 40.

Rotor Hats

GT Mount Hat Ordering Information										
ROTOR BOLT CIRCLE	WHEEL LUG PATTERN	HAT OFFSET	STUD HOLE DIAMETER	CENTER HOLE I.D.	FACE THICKNESS	CLEARANCE I.D.	MOUNT HOLE	HAT PART NUMBER	BOLT & T-NUT KIT NUMBER	NOTES
12 x 10.75"	8 x 6.50"	1.55"	.63"	4.64"	.45"	7.85"	5/16-18	170-8878	230-9068	
12 x 10.75"	6 x 5.50"	0.81"	.63"	3.09"	.45"	7.21"	5/16-18	170-8960	230-9068	
12 x 10.75"	6 x 5.32"	1.11"	.59"	3.42"	.25"	7.05"	5/16-18	170-9066	230-9068	
12 x 10.75"	5 x 4.72	0.81"	.59"	3.12"	.32"	7.20"	5/16-18	170-11729	230-9068	
12 x 10.75"	Undrilled	1.55"		2.40"	.45"	7.85"	5/16-18	171-11859	230-9068	
12 x 9.19"	6 x 5.50"	0.81"	.63"	3.09"	.45"	8.14"	1/4-28	170-9891	230-8217	
12 x 9.19"	5 x 4.75"	0.29"	.52"	2.78"	.30"	8.14"	1/4-20	170-8920	230-4572	
12 x 8.75"	5 x 5.50"	2.00"	.64"	4.28"	.25"	6.60"	1/4-20	170-12680	230-4572	
12 x 8.75"	5 x 5.00"	1.62"	.52"	3.06"	.25"	6.85"	1/4-20	170-10753	230-8008	
12 x 8.75"	5 x 5.00"	0.95"	.52"	2.80"	.32"	6.61"	1/4-20	170-12399	230-4572	
12 x 8.75"	5 x 4.75"	1.50"	.52"	3.06"	.25"	6.40"	1/4-20	170-11937	230-8008	(4)
12 x 8.75"	5 x 4.75"	0.71"	.52"	2.78"	.31"	7.49"	1/4-20	170-10533	230-4572	
12 x 8.75"	5 x 4.75"	0.56"	.52"	3.12"	.29"	7.75"	1/4-20	170-8815	230-4572	
12 x 8.75"	5 x 4.75"	0.41"	.52"	2.78"	.30"	7.72"	1/4-20	170-8132	230-4572	
12 x 8.75"	5 x 4.75"	0.29"	.52"	2.78"	.26"	7.72"	1/4-20	170-8919	230-8008	
12 x 8.75"	5 x 4.75"	0.23"	.52"	2.78"	.30"	7.75"	1/4-20	170-12390	230-8008	
12 x 8.75"	5 x 4.72/4.50"	1.00"	.67"	2.82"	.39"	7.75"	1/4-20	170-8757	230-4572	
12 x 8.75"	5 x 4.72"	0.75"	.50"	3.12"	.25"	8.01"	1/4-20	170-11975	230-4572	
12 x 8.75"	5 x 4.72"	0.71"	.48"	3.12"	.25"	7.49"	1/4-20	170-10970	230-8008	
12 x 8.75"	5 x 4.72"	0.53"	.64"	2.66"	.30"	7.24"	1/4-20	170-11305	230-4572	
12 x 8.75"	5 x 4.53"	1.20"	.63"	3.06"	.25"	7.09"	1/4-20	170-11766	230-4572	(4)
12 x 8.75"	5 x 4.50/4.75"	2.00"	.52"	3.06"	.25"	6.40"	1/4-20	170-7038	230-8008	
12 x 8.75"	5 x 4.50/4.75"	1.88"	.52"	3.06"	.25"	6.40"	1/4-20	170-6994	230-4572	
12 x 8.75"	5 x 4.50/4.75"	1.75"	.52"	3.06"	.25"	6.40"	1/4-20	170-7467	230-8008	
12 x 8.75"	5 x 4.50/4.75"	1.62"	.52"	3.06"	.25"	6.40"	1/4-20	170-10489	230-4572	(3)
12 x 8.75"	5 x 4.50/4.75"	1.62"	.52"	2.81"	.25"	6.40"	1/4-20	170-10620	230-4572	
12 x 8.75"	5 x 4.50/4.75"	1.50"	.52"	3.06"	.25"	6.40"	1/4-20	170-12516	230-4572	(4)
12 x 8.75"	5 x 4.50/4.75"	1.20"	.52"	3.00"	.25"	6.93"	1/4-20	170-8883	230-4572	
12 x 8.75"	5 x 4.50/4.75"	1.20"	.52"	3.06"	.25"	7.25"	1/4-20	170-10231	230-8008	
12 x 8.75"	5 x 4.50/4.75"	1.00"	.52"	3.06"	.25"	7.09"	1/4-20	170-12314	230-4572	
12 x 8.75"	5 x 4.50/4.75"	0.88"	.52/.58"	2.80"	.30"	7.25"	1/4-20	170-10149	230-4572	
12 x 8.75"	5 x 4.50/4.75"	0.88"	.52/.56"	2.78"	.30"	7.25"	1/4-20	170-6837	230-4572	
12 x 8.75"	5 x 4.50"	1.38"	.50"	3.06"	.28"	6.40"	1/4-20	170-11965	230-8008	(4)
12 x 8.75"	5 x 4.50"	1.00"	.52"	3.06"	.39"	7.75"	1/4-20	170-11328	230-4572	
12 x 8.75"	5 x 4.50"	0.81"	.52"	3.06"	.25"	7.25"	1/4-20	170-6126	230-4572	
12 x 8.75"	5 x 4.50"	0.70"	.63"	3.06"	.28"	7.09"	1/4-20	170-12050	230-8008	(4)
12 x 8.75"	5 x 4.50"	0.64"	.58"	2.80"	.31"	6.30"	1/4-20	170-9128	230-8008	
12 x 8.75"	5 x 4.50"	0.54"	.52"	2.77"	.25"	7.25"	1/4-20	170-10294	230-4572	
12 x 8.75"	5 x 4.50"	0.54"	.52"	2.53"	.25"	7.25"	1/4-20	170-10295	230-4572	
12 x 8.75"	5 x 4.50"	0.54"	.52"	2.44"	.25"	7.45"	1/4-20	170-10761	230-8008	
12 x 8.75"	5 x 4.50"	0.54"	.52"	3.06"	.25"	7.09"	1/4-20	170-11804	230-8008	(4)
12 x 8.75"	5 x 4.50"	0.54"	.52"	2.69"	.38"	7.25"	1/4-20	170-9289	230-4572	
12 x 8.75"	5 x 4.50"	0.41"	.58"	2.80"	.27"	7.75"	1/4-20	170-6223	230-4572	
12 x 8.75"	5 x 4.50"	0.21"	.52"	2.72"	.25"	8.01"	1/4-20	170-9558	230-8008	
12 x 8.75"	5 x 4.50"	-0.9"	.58"	3.06"	.31"	8.25"	1/4-20	170-12471	230-8008	(4)
12 x 8.75"	5 x 4.41"	0.70"	.59"	3.06"	.25"	7.09"	1/4-20	170-12791	230-4572	(4)
12 x 8.75"	5 x 3.94"	1.10"	.52"	2.29"	.27"	7.02"	1/4-20	170-6990	230-4572	
12 x 8.75"	5 x 3.93"	0.71"	.52"	2.17"	.30"	7.49"	1/4-20	170-9011	230-4572	
12 x 8.75"	4 x 4.50/5 x 4.50"	0.75"	.52"	2.69"	.38"	7.25"	1/4-20	170-9294	230-4572	
12 x 8.75"	4 x 3.93"	0.55"	.52"	2.17"	.25"	7.49"	1/4-20	170-8357	230-4572	
12 x 8.25"	5 x 4.75"	0.23"	.52"	2.78"	.30"	7.75"	1/4-20	170-12390	230-8008	
12 x 8.25"	5 x 4.50"	0.26"	.58"	2.80"	.32"	7.75"	1/4-20	170-12339	230-4572	
12 x 7.06"	5 x 4.75"	0.25"	.52"	2.78"	.30"	6.18"	1/4-20	170-7746	230-8008	
12 x 7.00"	5 x 4.75"	0.81"	.52"	2.78"	.30"	6.00"	1/4-20	170-8492	230-4572	
12 x 7.00"	5 x 4.50/4.75"	2.02"	.54"	2.66"	.25"	5.93"	1/4-20	170-9321	230-4572	
12 x 7.00"	5 x 4.50"	0.41"	.58"	2.80"	.25"	6.18"	1/4-20	170-12159	230-4572	
12 x 7.00"	5 x 4.50"	0.35"	.58"	2.80"	.27"	6.19"	1/4-20	170-8588	230-8008	
8 x 7.00"	5 x 5.00"	2.12"	.64"	3.06"	.25"	6.64"	5/16-18	170-2522	230-2589	(1)
8 x 7.00"	5 x 5.50"	0.81"	.67"	3.76"	.38"	6.16"	5/16-18	170-12612	230-12120	
8 x 7.00"	5 x 4.75"	1.59"	.52"	2.78"	.25"	6.04"	5/16-18	170-10782	230-8390	
8 x 7.00"	5 x 4.75"	0.88"	.52"	2.78"	.30"	6.00"	5/16-18	170-8493	230-8390	
8 x 7.00"	5 x 4.50/4.75"	1.43"	.52"	3.00"	.25"	6.04"	5/16-18	170-7632	230-3484	
8 x 7.00"	5 x 4.50/4.75"	1.16"	.52/.58"	2.80"	.25"	5.90"	5/16-18	170-10543	230-8390	
8 x 7.00"	5 x 4.50"	1.68"	.63"	3.06"	.45"	6.14"	5/16-18	170-12575	230-12120	(4)
8 x 7.00"	5 x 4.50"	1.23"	.58"	2.80"	.25"	5.90"	5/16-18	170-10041	230-8390	
8 x 7.00"	5 x 4.50"	1.16"	.50"	3.06"	.25"	5.90"	5/16-18	170-11802	230-12120	(4)
8 x 7.00"	5 x 4.50"	1.05"	.58"	2.78"	.28"	6.02"	5/16-18	170-8589	230-8390	
8 x 7.00"	5 x 4.50"	0.94"	.48/.52"	2.66"	.24"	5.90"	5/16-18	170-8320	230-8390	(2)
8 x 7.00"	5 x 4.50"	0.75"	.50"	2.80"	.25"	5.90"	5/16-18	170-10040	230-8390	
8 x 7.00"	5 x 4.50"	0.73"	.50"	2.53"	.25"	5.90"	5/16-18	170-6947	230-8390	
8 x 7.00"	5 x 4.50"	0.65"	.58"	2.80"	.25"	5.90"	5/16-18	170-10690	230-8390	
8 x 7.00"	5 x 3.93"	1.10"	.52"	2.28"	.27"	5.27"	5/16-18	170-9206	230-8390	
8 x 7.00"	5 x 3.93"	0.77"	.50"	2.30"	.32"	5.90"	5/16-18	170-8324	230-8390	
8 x 7.00"	5 x 3.93"	0.50"	.55"	2.40"	.25"	5.90"	5/16-18	170-6378	230-8390	
8 x 7.00"	5 x 3.93"	0.41"	.58"	2.57"	.25"	5.90"	5/16-18	170-8269	230-8390	
8 x 7.00"	4 x 4.50"	0.73"	.50"	2.72"	.25"	5.90"	5/16-18	170-6996	230-8390	

Rotor Hats

GT Mount Hat Ordering Information

ROTOR BOLT CIRCLE	WHEEL LUG PATTERN	HAT OFFSET	STUD HOLE DIAMETER	CENTER HOLE I.D.	FACE THICKNESS	CLEARANCE I.D.	MOUNT HOLE	HAT PART NUMBER	BOLT & T-NUT KIT NUMBER	NOTES
8 x 7.00"	4 x 4.25"	2.12"	.45"	3.06"	.25"	7.56"	5/16-18	170-11734	230-0526	(4)
8 x 7.00"	4 x 4.25"	1.18"	.52"	3.06"	.25"	5.90"	5/16-18	170-11903	230-12120	(4)
8 x 7.00"	4 x 4.25"	0.60"	.52"	3.06"	.24"	5.90"	5/16-18	170-11902	230-12120	(4)
8 x 7.00"	4 x 3.93"	1.16"	.50"	2.53"	.25"	5.90"	5/16-18	170-8405	230-8390	
8 x 7.00"	4 x 3.93"	0.83"	.64"	2.53"	.26"	5.90"	5/16-18	170-10650	230-8390	
8 x 7.00"	4 x 3.93"	0.75"	.50"	2.41"	.32"	5.90"	5/16-18	170-10200	230-8390	
8 x 7.00"	4 x 3.93"	0.45"	.64"	2.53"	.25"	5.90"	5/16-18	170-10868	230-8390	
8 x 7.00"	4 x 3.93"	0.45"	.50"	2.53"	.25"	5.90"	5/16-18	170-6288	230-8390	
8 x 7.00"	4 x 3.86"	0.61"	.50"	3.06"	.25"	5.90"	5/16-18	170-12771	230-8390	(4)
8 x 7.00"	2.87 x 2.4"	1.17"	.45"	2.75"	.38"	4.63"	5/16-18	170-5312	230-5337	
8 x 7.00"	Undrilled	1.22"	N/A	2.17"	.26"	6.40"	5/16-18	171-8976	230-8390	
8 x 7.00"	Undrilled	0.73"	N/A	2.40"	.25"	5.90"	5/16-18	171-7671	230-8390	
6 x 6.25"	5 x 3.35"	0.75"	.39"	2.75"	.32"	5.20"	5/16-18	170-12538	230-8991	
6 x 6.25"	4 x 3.93"	0.75"	.50"	2.41"	.32"	5.20"	5/16-18	170-10199	230-8991	
6 x 6.25"	4 x 3.93"	0.75"	.50"	3.06"	.32"	5.20"	5/16-18	170-11682	230-8991	(4)
6 x 6.25"	4 x 3.93"	0.66"	.50"	2.53"	.32"	5.10"	5/16-18	170-8643	230-8991	
6 x 6.25"	4 x 3.86"	0.64"	.50"	3.06"	.25"	5.20"	5/16-18	170-12770	230-8991	(4)
6 x 6.25"	Undrilled	0.77"	N/A	2.17"	.32"	5.10"	5/16-18	171-8975	230-8991	

NOTES:

- (1) This hat is drilled and countersunk to accommodate hat to hub anchoring screws. Screw kit part number 230-2482 contains five (5) grade 8 1/4-28 x 1.00" countersunk flat head hex drive screws and should be ordered in addition to the hat.
- (2) .48" / .52" dual pattern 5 x 4.50 stud hole sizes.
- (3) Hat is drilled and countersunk in three places to accommodate hat to hub anchoring screws used with specific Wilwood hat mount hubs.
- (4) 3.06" diameter register with counterbore for register ring.

HD Series Fixed Mount Rotor Hats

HD Series hats are manufactured from premium grade aluminum alloys offering high strength, low weight, and show quality appeal. HD hats have not only been a mainstay in many of Wilwood's racing disc brake conversion kits, but they can cover a range of applications from an OE four lug axle shaft to a Grand-National stock car racing hub. HD hats feature a straight bell construction with a flanged rotor mount ring. These features combine to provide maximum radial clearance between the caliper body and the hat. This can be a critical factor when trying to squeeze a large caliper inside a small wheel. Many hats offer multi-lug wheel patterns for added versatility. Some hats are available with no lug pattern for custom axle building and other unique applications.



The HD hat configurations are divided into two groups. There are threaded hole hats for use with through-hole mount rotors, and there are through-hole mount hats for use with threaded hole rotors. Hats are finished in black E-coat unless otherwise noted.

HD Fixed Mount Hat Ordering Information

ROTOR BOLT CIRCLE	WHEEL LUG PATTERN	HAT OFFSET	STUD HOLE DIAMETER	CENTER HOLE I.D.	FACE THICKNESS	CLEARANCE I.D.	MOUNT HOLE	HAT PART NUMBER	ROTOR BOLT KIT NUMBER	NOTES
5/16-24 Threaded Hole										
8 x 7.62"	6 x 5.00"	2.00"	.64"	3.50"	.25"	6.50"	.323"	170-0089	230-0150	(2)
8 x 7.62"	5 x 4.50/4.75/5.00"	2.00"	.52"	3.06"	.25"	6.50"	.323"	170-1827	230-0150	
8 x 7.62"	5 x 4.75"	1.50"	.51"	2.85"	.50"	6.51"	.323"	170-0176	230-0150	
8 x 7.62"	5 x 4.50"	2.10"	.50"	2.75"	.25"	6.31"	.323"	170-0636	230-0150	
8 x 7.62"	5 x 4.50"	1.38"	.67"	3.23"	.25"	6.27"	.323"	170-0635	230-0150	
8 x 7.62"	5 x 4.50"	1.25"	.52"	3.06"	.25"	6.32"	.323"	170-3265	230-0150	
8 x 7.62"	Undrilled	2.00"	—	2.78"	.25"	6.50"	.323"	171-2233	230-0150	
5/16" Through-Hole										
8 x 7.00"	5 x 4.75/5.00"	1.96"	.70"	3.06"	.25"	6.14"	5/16-18	170-5244	230-0233D	(1)
8 x 7.00"	5 x 4.50/4.75/5.00"	1.96"	.52"	3.06"	.25"	6.14"	5/16-18	170-0208	230-0233D	(1)
8 x 7.00"	5 x 4.50/4.75/5.00"	1.77"	.52"	3.06"	.25"	6.14"	5/16-18	170-0357	230-0233D	(1)
8 x 7.00"	5 x 4.50/4.75/5.00"	1.71"	.52"	3.06"	.25"	6.14"	5/16-18	170-0259	230-0233D	(1)
8 x 7.00"	5 x 4.50/4.75/5.00"	1.59"	.52"	3.06"	.25"	6.14"	5/16-18	170-0317	230-0233D	(1)
8 x 7.00"	5 x 4.50/4.75/5.00"	1.41"	.52"	3.06"	.50"	6.14"	5/16-18	170-0764	230-0233D	(1)
8 x 7.00"	Undrilled	1.96"	—	3.06"	.25"	6.14"	5/16-18	171-3753	230-0233D	(1)
8 x 7.00"	Undrilled	1.71"	—	3.06"	.25"	6.14"	5/16-18	171-3754	230-0233D	(1)
8 x 7.00"	Undrilled	1.59"	—	3.06"	.25"	6.14"	5/16-18	171-3755	230-0233D	(1)
8 x 7.00"	Undrilled	1.41"	—	2.78"	.50"	6.14"	5/16-18	171-2234	230-0233D	(1)

NOTES:

- (1) Rotor bolt kit part number 230-0233D includes a short profile hex head bolt that provides additional clearance between the bolt head and the caliper mounting hardware as used in Wilwood lightweight drag kits. These hats can also be used with bolt kit part number 230-2589, other applications where additional clearance exists between the rotor bolt head and the caliper mount hardware.
- (2) This hat is non-anodized.

Rotor Hats

Fixed Mount Iron Hats for Internal Parking Brakes & Bolt-on Rotors

These premium grade cast iron hats make it possible to use bolt-on rotors on vehicles equipped with internal shoe parking brake assemblies. Each hat is a precision machined, threaded hole design for use in conjunction with through-hole mount rotors. After machining, the hats are finished in black E-coat for corrosion resistance. Use the table below to match the rotor mount circle, lug pattern, offset, and other dimensions necessary for each application.



Ordering Information

ROTOR BOLT CIRCLE	WHEEL LUG PATTERN	HAT OFFSET	STUD HOLE DIAMETER	CENTER HOLE I.D.	FACE THICKNESS	CLEARANCE I.D.	MOUNT HOLE	HAT PART NUMBER	ROTOR BOLT KIT NUMBER	NOTES
12 x 10.75"	8 x 6.50"	1.91"	.64"	4.83"	.39"	7.87"	5/16-24	170-9607	230-9587	
12 x 10.75"	8 x 6.50"	1.78"	.64"	4.63"	.32"	7.87"	5/16-24	170-9608	230-9587	
12 x 10.75"	5 x 4.72"	1.50"	.59"	3.12"	.45"	8.03"	5/16-24	170-11730	230-9587	
12 x 9.19"	6 x 5.50"	2.34"	.63"	3.09"	.24"	7.29"	1/4-28	170-9890	230-8217	
12 x 8.75"	5 x 4.50/4.75/5.00"	1.95"	.52"	3.06"	.18"	6.85"	1/4-28	170-9493	230-8217	(1)
12 x 8.75"	5 x 4.50/4.75/5.00"	1.54"	.52"	3.06"	.18"	6.85"	1/4-28	170-9492	230-8217	(1)
12 x 8.75"	5 x 4.50/4.75/5.00"	1.54"	.52"	3.12"	.18"	6.85"	1/4-28	170-9984	230-8217	
12 x 8.75"	5 x 4.75"	1.70"	.52"	3.06"	.18"	6.48"	1/4-28	170-11938	230-8217	
12 x 8.75"	5 x 4.75"	1.60"	.45"	2.81"	.29"	6.42"	1/4-28	170-10621	230-8217	
12 x 8.75"	5 x 4.75"	1.32"	.52"	2.78"	.25"	6.47"	1/4-28	170-9839	230-8217	
12 x 8.75"	5 x 4.75"	0.67"	.52"	2.78"	.25"	7.10"	1/4-28	170-8169	230-8217	
12 x 8.75"	5 x 4.72"	0.73"	.64"	2.66"	.25"	6.26"	1/4-28	170-11306	230-8217	
12 x 8.75"	5 x 4.53"	1.34"	.52"	3.06"	.18"	6.85"	1/4-28	170-11767	230-8217	
12 x 8.75"	5 x 4.50"	1.21"	.51"	2.69"	.20"	6.65"	1/4-28	170-9455	230-8217	
12 x 8.75"	5 x 4.50"	0.81"	.51"	3.54"	.20"	6.11"	1/4-28	170-9599	230-8217	
12 x 8.75"	5 x 4.25"	1.54"	.52"	3.53"	.18"	6.85"	1/4-28	170-11860	230-8217	
12 x 8.75"	Undrilled	1.95"	—	3.06"	.18"	6.85"	1/4-28	171-12139	230-8217	
12 x 8.75"	Undrilled	1.54"	—	3.06"	.18"	6.85"	1/4-28	171-12138	230-8217	
8 x 7.78"	5 x 4.72"	2.08"	.55"	3.42"	.25"	5.87"	1/4-28	170-10961	230-7011	
8 x 7.78"	5 x 3.93"	1.64"	.51"	2.29"	.26"	5.76"	1/4-28	170-10108	230-7011	

NOTES:

(1) 3.06" diameter register with counterbore for register ring.

Fixed Mount Spun Steel Hats for Bolt-on Rotors



These lightweight, high-strength spun steel hats provide solid mounting of bolt-on rotors to OE axles and racing hubs when aluminum hats are not allowed. Each hat features a multi-hole lug pattern for universal application on the popular 5 lug mount patterns. These hats are not for use on parking brake applications.

Ordering Information

ROTOR BOLT CIRCLE	WHEEL LUG PATTERN	HAT OFFSET	STUD HOLE DIAMETER	CENTER HOLE I.D.	FACE THICKNESS	CLEARANCE I.D.	MOUNT HOLE	HAT PART NUMBER	ROTOR BOLT KIT NUMBER	NOTES
8 x 7.00"	5 x 4.50/4.75/5.00"	3.02"	.52"	3.06"	.09"	5.83"	.325"	170-3695	230-0840	

Technical Tip

Rotor Runout

Rotor runout should be adjusted as soon as you install your Wilwood components. Wilwood rotors are precision machined to ensure the rotor surfaces are flat and parallel. Sometimes hubs, bearings or other components have runout that cause the rotor to runout. As a rule of thumb, allowable runout should be less than .009". Adjust the runout by re-indexing the rotor on the hat. Runout should be rechecked regularly. You can assume the runout to be acceptable as long as you are not experiencing brake drag, pedal oscillation or excessive piston knock back.

Rotor Bolt Kits

Dynamic Mount Bolt Kits for Through Hole Rotors w/T-Slotted Hats or Plates

Bolt kits in this group include bolts, t-nuts and associated hardware to attach a standard through-hole mount rotor to a dynamic mount, t-slot machined hat or rotor plate. All bolts are lock-wire drilled.



Ordering Information

QTY	BOLT SIZE	BOLT TYPE	APPLICATIONS	KIT NO.
12	1/4-28 x .75"	Stainless Steel 12 Point	GT Hats	230-6656
8	1/4-28 x .75"	Stainless Steel 12 Point	GT Hats	230-6709
8	5/16-24 x .81"	Stainless Steel 12 Point	GT Hats, 5 x 5 Hub Plate	230-6710
8	5/16-24 x .75"	Grade 8 Socket Head	Wide 5 Hub Plate	230-8454
8	5/16-24 x .75"	Grade 8 Short Profile Hex	Rear Axle GT Drag Hats	230-7666

Dynamic Mount Bolt Kits for Slotted Hole Steel Rotors

These bolt kits include bolts, t-nuts, and associated hardware to attach a specially machined slotted hole plate steel rotor to a threaded hat, hub, or live axle rotor clamp. All kits are supplied with either lock-wire drilled bolts or lock nuts.



Ordering Information

QTY	BOLT SIZE	BOLT TYPE	APPLICATIONS	KIT NO.
8	5/16-24 x 1.25"	Grade 8 Countersunk	Live Axle Rotor Clamp	230-5567 ⁽¹⁾
8	5/16-24 x .81"	Grade 8 Socket Head	Threaded Hats, Wide 5 Hubs	230-5308

Bolt Kits for Fixed Mount Threaded or Through Hole Mount Rotors

Bolt kits in this group include bolts, and any other necessary hardware to attach a threaded or through hole mount rotor or rotor mounting plate to a threaded or through hole mount hat, hub, or live axle rotor clamp. With some exceptions, all bolts are lock wire drilled.



Ordering Information

QTY	BOLT SIZE	BOLT TYPE	APPLICATIONS	KIT NO.
16	5/16-18 x 1.00"	Stainless, Torx Button Head	8 on 7.00" Rotor	230-12176 ⁽²⁾
16	5/16-18 x 0.75"	Stainless, Torx Button Head	8 on 7.00" Rotor	230-12120 ⁽²⁾
12	5/16-18 x 1.00"	Stainless, Torx Button Head	6 on 6.25" Rotor	230-12177 ⁽²⁾
12	5/16-18 x 0.75"	Stainless, Torx Button Head	6 on 6.25" Drag Rotor	230-12121 ⁽²⁾
12	5/16-18 x 1.00"	Grade 8 Hex Head	TC Hats	230-9068
12	1/4-20 x 1.00"	Stainless Steel 12 Point	GT Hats	230-4572
12	1/4-20 x 0.75"	Stainless Steel 12 Point	GT Hats, ProMatrix Kits	230-8008
8	5/16-24 x 1.00"	Grade 8 Socket Head	Steel Hats with Through Hole Rotors	230-0840 ⁽¹⁾
8	5/16-24 x 0.75"	Grade 8 Socket Head	Threaded Rotors on Through Hole Hats	230-0150
8	5/16-18 x 1.00"	Grade 8 Hex Head	Wide 5 Hubs, Threaded Hats, Undrilled	230-0526 ⁽²⁾
8	5/16-18 x 1.00"	Grade 8 Hex Head	BB Hats	230-8390
8	5/16-18 x 1.00"	Grade 8 Socket Head	GT Hats, Wide 5 Hubs	230-2589
8	5/16-18 x 0.75"	Grade 8 Short Profile Hex	8 on 7.00" P/S Rotor Plate	230-3484
8	5/16-18 x 0.75"	Grade 8 Short Profile Hex	Drag Race Rear Axle Kits	230-0233D
8	1/4-28 x 1.00"	Grade 8 Socket Head	2 Piece Internal Parking Brake	230-6409
8	1/4-28 x 0.75"	Grade 8 Socket Head	Subaru WRX Rear	230-7011
6	5/16-18 x 0.75"	Grade 8 Hex Head	6 on 6.25" P/S Drag Rotor Plate	230-3328
5	3/8-18 X 1.00"	Grade 8 Torx	Rotor Plate to P/S Hub	230-3829 ⁽²⁾

NOTES: (1) Includes lock nuts • (2) Not lock wired drilled

Hat / Rotor Universal Adapter Ring

These adapter rings are utilized with Wilwood hat/rotors on axles with center register diameters smaller than 3.06".



Ordering Information

REGISTER I.D.	PART NUMBER	REGISTER I.D.	PART NUMBER
2.87"	300-11732	2.51"	300-11901
2.84"	300-11962	2.44"	300-12761
2.82"	300-11338	2.33"	300-12777
2.80"	300-11337	2.18"	300-11653
2.78"	300-11532	2.00"	300-11339
2.56"	300-12792		
2.54"	300-12395		
2.52"	300-11803		

Performance Hubs

Forged Billet Performance Hubs

Wilwood's Forged Billet Hubs are made from premium grade alloy billets that are forged into shape under high heat and pressure, then CNC machined for precise fit on each spindle application. Specific hub styles are available for either hat mounting of rotors, or direct mounting of rotors by using intermediate rotor adapters. Hubs are either single or double drilled from 5 on 4.00" up to 5 on 5.00" wheel lug patterns depending on part number. Hubs include installed bearing races and screw-on aluminum dust caps. For more detailed and/or up-to-date information please download our hub data sheet at www.wilwood.com/pdf/ds719.pdf

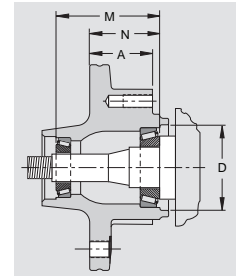

Performance Hubs Ordering Information

HUB PART NUMBER	DESCRIPTION VEHICLE TYPE	WHEEL BC	ROTOR OFFSET	DIM A	DIM D	DIM M	DIM N	WILWOOD INNER RACE PART #	WILWOOD OUTER RACE PART #	WILWOOD INNER BEARING PART #	WILWOOD OUTER BEARING PART #	INNER BEARING SHAFT OD	OUTER BEARING SHAFT OD
270-3204	87-93 MUST 4 LUG	A	H	N/A	2.574	2.93	1.54	370-2571	370-0881	370-2609	370-0882	1.3750	0.8656
270-3268	87-93 MUST 5 LUG	B	H	N/A	2.574	2.93	1.54	370-2571	370-0881	370-2609	370-0882	1.3750	0.8656
270-6989	PINTO/MUST BB	C	H	N/A	2.495	3.15	2.06	370-0883	370-0881	370-0884	370-0882	1.3775	0.8656
270-7037	64-72 NOVA BB	C	H	N/A	2.495	3.15	2.37	370-0878	370-0876	370-0879	370-0877	1.2500	0.7500
270-7274	67-74 NOVA	C	V	1.795	2.495	3.15	2.39	370-0878	370-0876	370-0879	370-0877	1.2500	0.7500
270-7275	67-74 NOVA	C	S	1.850	2.495	3.15	2.06	370-0878	370-0876	370-0879	370-0877	1.2500	0.7500
270-7276	PINTO/MUST	C	V	1.795	2.495	3.15	2.39	370-0883	370-0881	370-0884	370-0882	1.3775	0.8656
270-7277	PINTO/MUST	C	S	1.850	2.495	3.15	2.06	370-0883	370-0881	370-0884	370-0882	1.3775	0.8656
270-7279	37-48 FORD	C	V	1.940	2.502	4.12	2.41	370-1560	370-0876	370-1561	370-0877	1.1895	0.7500
270-7281	37-48 FORD	C	S	2.375	2.502	4.12	2.41	370-1560	370-0876	370-1561	370-0877	1.1895	0.7500
270-7283	55-57 CHEV	C	V	1.795	2.495	3.07	2.41	370-0878	370-0876	370-0879	370-0877	1.2500	0.7500
270-7285	87-93 MUST	C	S	1.882	2.574	2.93	2.12	370-2571	370-0881	370-2609	370-0882	1.3750	0.8656
270-7287	GRANADA	C	V	1.966	2.495	3.02	1.90	370-0883	370-0881	370-0884	370-0882	1.3775	0.8656
270-7309	80-87 G-BODY	C	V	1.795	2.495	3.15	2.39	370-0878	370-0881	370-0879	370-0933	1.2500	0.8437
270-7309-P	80-87 G-BODY	C	V	1.795	2.495	3.15	2.39	370-0878	370-0881	370-0879	370-0933	1.2500	0.8437
270-7310	80-87 G-BODY	C	S	1.850	2.495	3.15	2.06	370-0878	370-0881	370-0879	370-0933	1.2500	0.8437
270-7311	VEGA	C	S	1.850	2.495	3.38	2.16	370-0878	370-1238	370-0879	370-1239	1.2500	0.6875
270-7466	GRANADA BB	C	H	N/A	2.495	3.02	1.72	370-0883	370-0881	370-0884	370-0882	1.3775	0.8656
270-7631	55-57 CHEVY BB	C	H	N/A	2.495	2.97	1.52	370-0878	370-0876	370-0879	370-0877	1.2500	0.7500
270-7680	87-93 MUST	C	V	1.752	2.573	2.93	2.36	370-2571	370-0881	370-2609	370-0882	1.3750	0.8656
270-8767	65-72 A BODY 10"	D	V	1.795	2.332	2.97	2.41	370-0878	370-0876	370-0879	370-0877	1.2500	0.7500
270-8769	65-72 A BODY 10"	D	S	1.850	2.332	2.97	2.09	370-0878	370-0876	370-0879	370-0877	1.2500	0.7500
270-8771	62-72 A BODY 9"	D	V	1.800	2.433	2.95	2.30	370-3146	370-1238	370-3147	370-1239	1.0625	0.6875
270-8773	62-72 A BODY 9"	D	S	2.080	2.433	2.95	2.07	370-3146	370-1238	370-3147	370-1239	1.0625	0.6875
270-8775	73-76 A BODY DSC	D	V	1.906	2.619	3.73	2.31	370-0883	370-0876	370-0884	370-0877	1.3775	0.7500
270-8777	73-76 A BODY DSC	D	S	1.956	2.619	3.70	2.02	370-0883	370-0876	370-0884	370-0877	1.3775	0.7500
270-8779	62-72 B/E BODY	D	V	1.906	2.332	3.74	2.31	370-0878	370-0876	370-0879	370-0877	1.2500	0.7500
270-8781	62-72 B/E BODY	D	S	1.926	2.332	3.70	2.02	370-0878	370-0876	370-0879	370-0877	1.2500	0.7500
270-9320	70-73 MUSTANG BB	C	H	N/A	2.495	3.13	1.69	370-0883	370-0881	370-0884	370-0882	1.3775	0.8656
270-9486	PINTO/MUST BB	C	H	N/A	2.495	3.15	1.63	370-0883	370-0881	370-0884	370-0882	1.3775	0.8656
270-9502	68-69 MUSTANG BB	C	H	N/A	2.495	3.13	1.69	370-0883	370-0881	370-0884	370-0882	1.3775	0.8656
270-10044	WWE PRO SPINDLE	C	V	1.750	2.495	3.15	1.74	370-0883	370-0881	370-0884	370-0882	1.3775	0.8656
270-10237	LARGE GM	C	H	N/A	2.495	3.21	1.97	370-0878	370-0876	370-0879	370-0877	1.2500	0.7500
270-10438	CAMARO 70-78	C	V	1.584	2.495	3.15	1.64	370-0878	370-0876	370-0879	370-0877	1.2500	0.7500
270-10439	CAMARO 79-81	C	V	1.584	2.495	3.15	1.64	370-0878	370-0881	370-0879	370-0933	1.2500	0.8437
270-10442	PINTO/MUST	C	V	1.584	2.495	3.15	1.64	370-0883	370-0881	370-0884	370-0882	1.3775	0.8656
270-10487	CAMARO 70-78	C	H	N/A	2.495	3.15	1.63	370-0878	370-0876	370-0879	370-0877	1.2500	0.7500
270-10494	CAMARO 79-81	C	H	N/A	2.495	3.15	1.63	370-0878	370-0881	370-0879	370-0933	1.2500	0.8437
270-10658	PINTO/MUST BB	E	H	N/A	2.495	3.15	2.06	370-0883	370-0881	370-0884	370-0882	1.3775	0.8656
270-10660	PINTO/MUST	E	V	1.795	2.495	3.15	2.39	370-0883	370-0881	370-0884	370-0882	1.3775	0.8656
270-10762 ⁽¹⁾	CHEVY C10	E	H	N/A	2.561	3.57	1.71	370-2571	370-9245	370-2609	370-9542	1.3750	0.8437
270-10812	62-72 B/E BODY	C	H	N/A	2.332	3.71	1.89	370-0878	370-0876	370-0879	370-0877	1.2500	0.7500
270-11032	55-57 CHEVY	C	V	1.150	2.495	2.97	1.83	370-0878	370-0876	370-0879	370-0877	1.2500	0.7500
270-11043	80-87 G-BODY	C	V	1.724	2.495	3.15	1.52	370-0878	370-0881	370-0879	370-0933	1.2500	0.8437
270-11048	CAMARO 79-81	C	V	2.135	2.495	3.15	1.84	370-0878	370-0881	370-0879	370-0933	1.2500	0.8437
270-11050	CAMARO 70-78	C	V	2.135	2.495	3.15	1.84	370-0878	370-0876	370-0879	370-0877	1.2500	0.7500
270-11058	MUSTANG 65-69	C	V	0.913	2.495	3.15	1.76	370-0878	370-0876	370-0879	370-0877	1.2500	0.7500
270-11070	MUSTANG 70-73	C	V	0.913	2.495	3.15	1.76	370-0883	370-0881	370-0884	370-0882	1.3775	0.8656

NOTES:

(1) Hub does not include cap assembly. Order one quantity part number 370-10763 for two hubs.

WHEEL BC	STUD HOLE SIZE	WHEEL BC	STUD HOLE SIZE	CODES
A = 4 x 4.25	1/2-20	F = 5 x 4.75	1/2-20	H = FOR USE WITH HAT
B = 5 x 4.50	1/2-20	G = 4 x 4.25	7/16-20	S = SOLID, .35" THICK (USES DIRECT MOUNT SOLID ROTOR, OR ROTOR ADAPTER: 300-3307)
C = 5 x 4.50 & 4.75	1/2-20	H = 5 x 4.75 & 5.00	1/2-20	V = VENTED, .81" THICK (USES ROTOR ADAPTER: 300-3307 OR 300-3099)
D = 5 x 4.00 & 4.50	1/2-20	I = 4 x 4.50		
E = 5 x 5.00	1/2-20			

Performance Hubs

Performance Hubs Ordering Information

HUB PART NUMBER	DESCRIPTION VEHICLE TYPE	WHEEL BC	ROTOR OFFSET	DIM A	DIM D	DIM M	DIM N	WILWOOD INNER RACE PART #	WILWOOD OUTER RACE PART #	WILWOOD INNER BEARING PART #	WILWOOD OUTER BEARING PART #	INNER BEARING SHAFT OD	OUTER BEARING SHAFT OD
270-11252	PINTO/MUST	C	V	1.720	2.495	3.14	1.64	370-0883	370-0881	370-0884	370-0882	1.3775	0.8656
270-11256	87-93 MUSTANG	C	V	1.146	2.573	2.93	1.87	370-2571	370-0881	370-2609	370-0882	1.3750	0.8656
270-11516	62-72 B/E BODY	D	V	1.720	0.570	3.74	2.19	370-0878	370-0876	370-0879	370-0877	1.2500	0.7500
270-11527	62-72 A BODY - 9"	D	V	1.170	0.570	2.95	1.96	370-11554	370-1238	370-11555	370-1239	1.0625	0.6875
270-11533	73-76 A BODY DISC	C	H	N/A	0.570	3.73	2.06	370-0883	370-0876	370-0884	370-0877	1.3775	0.7500
270-11539	65-72 A BODY - 10"	D	V	1.145	0.570	2.97	1.95	370-0878	370-0876	370-0879	370-0877	1.2500	0.7500
270-11746	SUNBEAM TIGER	G	H	N/A	2.432	3.14	2.43	370-11758	370-0876	370-1236	370-0877	1.1250	0.7500
270-11813	49-54 CHEVY	H	V	1.130	2.500	3.70	1.88	370-0883	370-0876	370-0884	370-0877	1.3775	0.7500
270-11942	AMC	C	V	1.694	2.495	3.15	1.96	370-0878	370-0876	370-0879	370-0877	1.2500	0.7500
270-12024	65-68 IMPALA	C	V	1.130	2.495	3.15	1.70	370-0878	370-0876	370-0879	370-0877	1.2500	0.7500
270-12038	69-70 IMPALA	C	V	1.130	2.581	3.12	1.70	370-2571	370-9245	370-2609	370-9542	1.3750	0.8437
270-12273	PINTO/MUST BB	C	H	N/A	2.495	3.15	1.93	370-0883	370-0881	370-0884	370-0882	1.3775	0.8656
270-12277	CAMARO 70-78	C	H	N/A	2.495	3.15	1.76	370-0878	370-0876	370-0879	370-0877	1.2500	0.7500
270-12279	CAMARO 79-81	C	H	N/A	2.495	3.15	1.76	370-0878	370-0881	370-0979	370-0933	1.2500	0.8437
270-12281	73-76 A BODY DSC	C	H	N/A	2.331	2.02	2.02	370-0883	370-0876	370-0884	370-0877	1.3775	0.7500
270-12304	80-87 G-BODY	C	H	N/A	2.495	1.37	1.37	370-0878	370-0881	370-0879	370-0933	1.2500	0.8437

WHEEL BC	STUD HOLE SIZE	WHEEL BC	STUD HOLE SIZE	CODES
A = 4 x 4.25	1/2-20	F = 5 x 4.75	1/2-20	H = FOR USE WITH HAT
B = 5 x 4.50	1/2-20	G = 4 x 4.25	7/16-20	S = SOLID, .35" THICK (USES DIRECT MOUNT SOLID ROTOR, OR ROTOR ADAPTER: 300-3307)
C = 5 x 4.50 & 4.75	1/2-20	H = 5 x 4.75 & 5.00	1/2-20	V = VENTED, .81" THICK (USES ROTOR ADAPTER: 300-3307 OR 300-3099)
D = 5 x 4.00 & 4.50	1/2-20	I = 4 x 4.50		
E = 5 x 5.00	1/2-20			

Rotor Adapters Ordering Information

ROTOR BOLT CIRCLE	HUB BOLT CIRCLE	PART NO.
6 x 6.25"	5 x 3.88"	300-3307
8 x 7.00"	5 x 3.88"	300-3099



Wheel Studs Ordering Information

QTY	BOLT SIZE	BOLT TYPE	APPLICATION	PART NO.
1	1/2-20 x 1.75"	GRADE 8 - 12 POINT	PRO STREET HUBS	230-2187
1	1/2-20 x 2.00"	GRADE 8 - 12 POINT	HAT MOUNT HUBS	230-6959
1	1/2-20 x 3.00"	GRADE 8 - SOCKET HEAD	DRAG HUBS	230-0921

Bolt Kits Ordering Information

QTY	BOLT SIZE	BOLT TYPE	APPLICATION	PART NO.
5	3/8-16 x 1.00"	GRADE 8 - TORX BHCS	ROTOR ADAPTER TO HUB	230-3829
6	5/16-18 x .75"	GRADE 8-HEX HEAD-LWD	ROTOR TO ROTOR ADAPTER	230-3328
8	5/16-18 x .75"	GRADE 8-HEX HEAD-LWD	ROTOR TO ROTOR ADAPTER	230-3484
12	5/16-18 x .75"	STAINLESS - TORX BHCS	ROTOR TO ROTOR ADAPTER	230-12121
16	5/16-18 x .75"	STAINLESS - TORX BHCS	ROTOR TO ROTOR ADAPTER	230-12120
6	1/4-20 x .50"	GRADE 8 - FLAT HEAD	HAT TO HUB BOLTS	230-7032

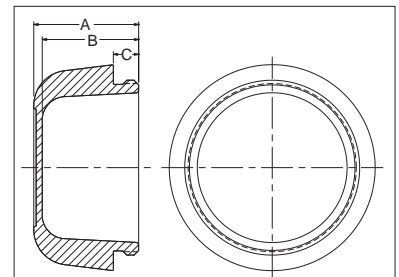

Replacement Hub Caps Ordering Information

DIM "A"	DIM "B"	DIM "C"	PART NO.
0.890"	0.800"	0.270"	270-9380
0.920"	0.830"	0.270"	270-3150
1.120"	1.030"	0.270"	270-2158

Wide 5 Hubs

Starlite 55-XD Wide 5 Racing Hubs

Starlite 55-XD hubs elevate performance and versatility for racing applications that require uncompromised strength without excessive additional weight. At just over 7 pounds, the 55-XD achieves its superior strength and modest weight through a highly efficient redesign of racing's most popular wide 5 hub.

The 55-XD employs a bolt-on rotor mount plate that adds overall strength by eliminating the brake torque loading from the main hub body. For heavier vehicles, vehicles running high speeds on high banked tracks, or vehicles that run on uncommonly rough tracks, taking the stress loads of the braking torque out of the hub body and moving it to the thicker, stronger section of the hub near the inner wheel bearing, provides a measurable decrease in stress deflection in the body and a measurable increase in durability.

The rotor mount plates are configured for both fixed and dynamic rotor mounting by simply changing the bolt kits. With dynamic mount t-nut rotor bolt kits, stresses from the dissimilar thermal expansion rates of the iron rotor and the aluminum mount are fully isolated from the hub body, and the rotor mount plate as well. For less extreme temperature applications, the rotors can be fixed mounted.

All 55-XD hubs feature our black e-coat finish to seal the castings and preserve their good looks. Rotor mount plates, and the bolts to attach the plate to the hub, are included with all hubs. Front hubs include Snap Cap dust covers. Rear drive flanges, bolt-on dust caps to use a rear hub in a front location, and all rotor bolt kits must be ordered separately.



Starlite 55-XD Wide 5 Front Racing Hub
Front View Shown Left, Rear View Shown Right

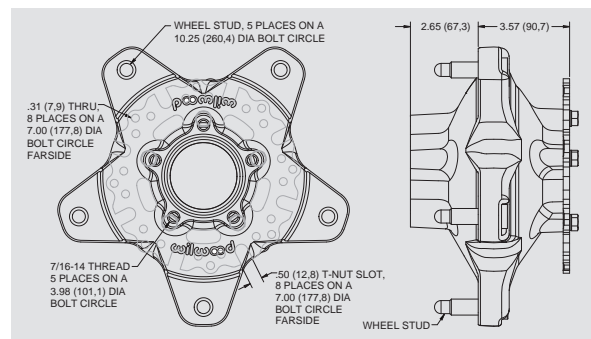

Starlite 55-XD Wide 5 Ordering Information

DESCRIPTION	STUDS	WEIGHT	PART NUMBER
Front Hub with Snap Cap, Rotor Mount Plate	5/8" Coarse	7 Lbs, 5.2 oz	270-12127C
Rear Hub, Rotor Mount Plate	5/8" Coarse	7 Lbs, 6.8 oz	270-12111C

Starlite Wide 5 Racing Hubs

Starlite hubs remain as the oval track benchmark standard. Based on the traditional eight-bolt drive flange design, Starlite hubs demonstrate superior strength from permanent mold, high density aircraft aluminum. The close tolerance castings are precision machined to assure consistent fit, strength, and durability. Over the years, this innovative hollow core design has been refined and is race proven. Wilwood's high volume, quality assured manufacturing capability has made it both racing tough and economical.

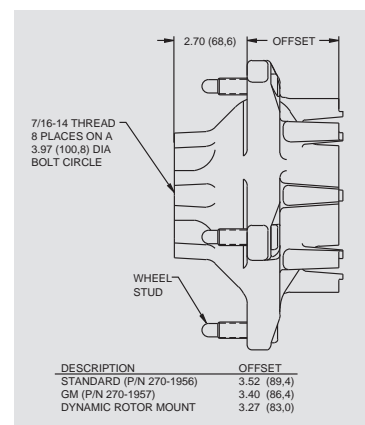

Starlite hubs are available in standard offset for use with Superlite, Dynalite, and Narrow Mount Dynalite series fixed mount calipers. The GM offset is available for use with GM style floating mount calipers. A new offset configuration is also available to accommodate the thickness of dynamic rotor mounting plates. Fine threaded 5/8" studs are also an option on the Starlite series.

Starlite Wide 5 Ordering Information

OFFSET	FINISH	STUDS	WEIGHT	PART NUMBER
Standard	Aluminum	5/8" Coarse	7 Lbs, 12.2 oz	270-1956C
GM	Aluminum	5/8" Coarse	7 Lbs, 5.6 oz	270-1957C
Dynamic Mount ⁽¹⁾	Aluminum	5/8" Coarse	7 Lbs, 11.2 oz	270-8434C ⁽¹⁾
Dynamic Mount ⁽¹⁾	Aluminum	5/8" Coarse Drilled	7 Lbs, 6.4 oz	270-8434D ⁽¹⁾

NOTES:

(1) Dynamic mount hubs require: Rotor plate part number 300-8431 and bolt kit part number 230-8454 to complete. See pages 37 and 42.

Wide 5 Hubs

Starlite "55" Wide 5 Racing Hubs

Starlite "55" hubs provide the superior strength of permanent mold, high density aircraft aluminum at weights comparable to the much higher priced magnesium hub assemblies. The Starlite "55" features the strength of our traditional eight bolt Starlite hub, but with a redesign focused on eliminating unnecessary weight in the hub and its related components.

Rear hubs (right, top photo) have been reconfigured to include five bolt drive flanges and weigh in at less than 7 pounds with bearing races and studs installed. When combined with the additional weight savings of the five bolt drive flange and bolt kit, the assembled hub meets or beats the assembled weight of nearly every eight bolt magnesium hub assembly available.

Front hubs (right, bottom photo) offer further weight reduction by completely eliminating the bolt bosses with the use of a fiber reinforced composite Snap-Cap dust cover. Optional drilled studs round-out the total lightweight package. Starlite "55" hubs are available in the traditional GM or standard rotor mount offset, with an all new configuration available for use with Wilwood's dynamic rotor mount plates. Standard offset hubs can be ordered with a special black coating that seals the surface and maintains a clean appearance against oxidation and corrosion from track born substances.

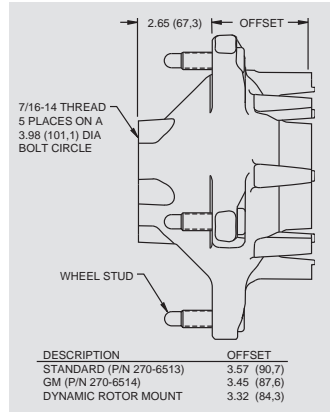

Starlite "55" Ordering Information

OFFSET	FINISH	STUDS	WEIGHT	PART NUMBER
Rear 5 Bolt Drive				
Standard	Aluminum	5/8" Coarse	7 Lbs, 8.0 oz	270-6513C
Standard	Aluminum	5/8" Coarse Drilled	7 Lbs, 4.0 oz	270-6513D
Standard	Black	5/8" Coarse	7 Lbs, 8.0 oz	270-6513BC
Standard	Black	5/8" Coarse Drilled	7 Lbs, 4.0 oz	270-6513BD
Dynamic Mount ⁽¹⁾	Aluminum	5/8" Coarse	7 Lbs, 1.2 oz	270-8435C ⁽¹⁾
Dynamic Mount ⁽¹⁾	Aluminum	5/8" Coarse Drilled	6 lbs, 12.0 oz	270-8435D ⁽¹⁾
Front w/Snap-Cap				
Standard	Aluminum	5/8" Coarse	7 Lbs, 9.0 oz	270-6735C
Standard	Aluminum	5/8" Coarse Drilled	7 Lbs, 4.4 oz	270-6735D
Standard	Black	5/8" Coarse	7 Lbs, 9.0 oz	270-6735BC
Standard	Black	5/8" Coarse Drilled	7 Lbs, 4.4 oz	270-6735BD
Dynamic Mount ⁽¹⁾	Aluminum	5/8" Coarse	7 Lbs, 1.8 oz	270-8436C ⁽¹⁾
Dynamic Mount ⁽¹⁾	Aluminum	5/8" Coarse Drilled	6 Lbs, 13.0 oz	270-8436D ⁽¹⁾

NOTES:

(1) Dynamic mount hubs require: Rotor plate part number 300-8431 and bolt kit part number 230-8454 to complete. See pages 38 and 42.

Wide 5 Wheel Spacer



Wilwood's unique 2" offset aluminum Wide 5 Wheel Spacer utilizes a radical triangulated design to achieve maximum strength and rigidity. This race proven wheel spacer is lighter than any other on the market. Available with coarse 5/8" studs, Wilwood's 4.1 pound spacer gives greater flexibility in chassis setup while keeping rotating weight to a minimum.

Wheel Spacer Ordering Information

DESCRIPTION	PART NO.
2" Offset Wheel Spacer, Coarse Studs	270-2189C

Wide 5 Hubs

Wide 5 Hub Parts and Accessories



Plate to Hub Bolt Kit



Lightweight 5 Bolt Drive Flange



Bearing, Seal & Locknut Kit



8 Bolt Drive Flange

Starlite "55" Drive Flanges/Hub Caps Ordering Information

DESCRIPTION	PART NO.
Standard Five Bolt Drive Flange with Bolts, Washers	270-6732
Lightweight Five Bolt Drive Flange with Bolts, Washers	270-6733
Snap-Cap Front Hub Dust Cover	270-6913
Five Bolt Lightweight Steel Front Hub Cap, Gold Cad Plated	270-9498
Drive Flange Bolts with Washers - 5 Pack	270-6911
O-Ring, Snap-Cap	211-6950

Starlite Drive Flanges/Hub Caps Ordering Information

DESCRIPTION	PART NO.
Eight Bolt Drive Flange, Gold	270-2290
Eight Bolt Drive Flange, Black	270-2290B
Eight Bolt Drive Flange, Red	270-2290R
Eight Bolt Lightweight Steel Front Hub Cap, Gold Cad Plated	270-0374
Drive Flange / Hub Cap Bolt Kit - 8 Pack	230-1378

Bearing, Seals, and Spindle Locknuts Ordering Information

DESCRIPTION	PART NO.
Bearing, Seal and Self Lock Spindle Nut Kit	370-6885
Bearing and Seal Only Kit	370-0563
Self-Lock Spindle Nut	230-6659
Seal	380-0429
Inner Bearing	370-0431
Inner Hub Bearing Race	370-0314
Outer Bearing	370-0432
Outer Hub Bearing Race	370-0315

Studs and Lug Nuts Ordering Information

DESCRIPTION	PART NO.
5/8" Coarse Stud - 5 pack	230-0620
5/8" Coarse Stud - Bulk (100 piece minimum)	230-0510
5/8" Coarse Stud, Gun Drilled - Bulk (100 piece minimum)	230-6459
5/8" Coarse Lug Nut - 5 pack	230-0622
5/8" Coarse Lug Nut - Bulk (100 piece minimum)	230-0511
5/8" Fine Stud - Bulk (100 piece minimum)	230-0304
5/8" Fine Lug Nut - Bulk (100 piece minimum)	230-0512

Starlite 55-XD Accessories & Service Parts Ordering Information

DESCRIPTION	PART NO.
Rotor Bolt Kit, Dynamic Mount with T-Nuts	230-8454
Rotor Bolt Kit, Fixed Mount with lock Nuts	230-0840
Rear Drive Flange Kit with Bolts	270-6732
Front Hub Cap, Lightweight Steel, 5 Bolt	270-9498
Drive Flange and Hub Cap Bolt Kit, 5 Pack	230-6911

Pedal Assemblies

Floor Mount Triple Pedal Assembly

This floor mount pedal assembly has a brake / clutch / throttle triple pedal design. There are three individual fabricated steel pedals with non-slip pedal pads to control brake, clutch and throttle. Pedal assembly part number 340-12410 is for rear engine cars and part number 340-12411 is for front engine cars. Both units feature an aluminum frame with strong lightweight fabricated steel pedal arms. The frame and the pedal arms have a black e-coat finish for protection and an attractive appearance. Also included with the pedal assembly are mounting studs, clevises, and balance bar assembly that is designed to provide smooth and accurate settings of the brake pedal bias. The balance bar can be set and locked down with the jam nut, or attached to a remote cable for quick on-track adjustments. The pedal assembly provides a 5.25 to 1 nominal ratio.

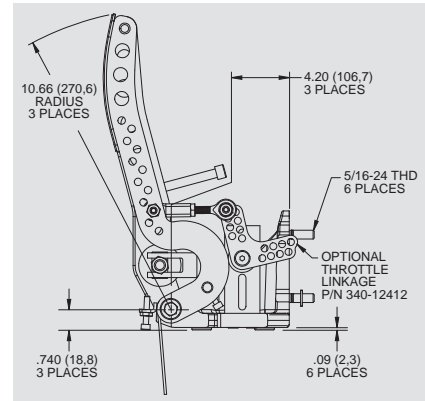

Also included with the pedal assembly are mounting studs, clevises, and balance bar assembly that is designed to provide smooth and accurate settings of the brake pedal bias. The balance bar can be set and locked down with the jam nut, or attached to a remote cable for quick on-track adjustments. The pedal assembly provides a 5.25 to 1 nominal ratio.

Assembly Instructions:

- Pedal assembly part number 340-12410 requires the customer to do the final assembly of the throttle pedal to the main pedal assembly. Kit part number 340-12411 requires using the same procedure as part number 340-12410 with the additional step of installing the throttle linkage assembly, part number 340-12412 that is necessary for front engine vehicles.

Pedal Ordering Information

DESCRIPTION	PART NUMBER
Floor Mount Triple Pedal Assembly for Rear Engine Cars, 5.25:1 Nominal Ratio	340-12410 ⁽¹⁾
Floor Mount Triple Pedal Assembly with Throttle Linkage for Front Engine Cars, 5.25:1 Nominal Ratio	340-12411 ⁽¹⁾
Throttle Linkage for Front Engine Pedal Assembly	340-12412

Adjustable Forward Swing Mount Triple Master Cylinder Pedal - Aluminum

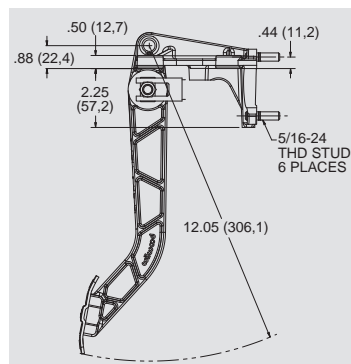

Wilwood's adjustable forward mount pedal assembly combines the brake and clutch pedals together in one unit and positions the master cylinders outside the firewall. It features all aluminum frame and forged aluminum pedal arms with ladder style construction. Pedal pads are of special adjustable design that allows fine-tuning of the pedal location and clearance. A new clevis/pivot pin balance bar assembly provide smooth and accurate settings of the brake pedal bias. The balance bar can be set and locked down with the jam nut, or attached to a remote cable for quick on-track adjustments. This assembly creates a 6.25 to 1 pedal ratio on both clutch and brake pedals.

Pedal Ordering Information

DESCRIPTION	PART NUMBER
Adjustable Forward Mount Triple Master Cylinder Pedal Assembly, 6.25:1 Ratio	340-11295 ⁽¹⁾

NOTES:

(1) Pedals are shown with optional master cylinders which must be ordered separately. See pages 59-61 for available selections.

Pedal Assemblies

Adjustable Reverse Swing Mount Triple Master Cylinder Pedal - Aluminum

Wilwood's adjustable reverse mount pedal assembly combines the brake and clutch pedals together in one unit and positions the master cylinders inside the firewall, away from engine heat. It features all aluminum frame and forged aluminum pedal arms with ladder style construction. Pedal pads are of special adjustable design that allows fine-tuning of the pedal location and clearance. A new clevis/pivot pin balance bar assembly provide smooth and accurate settings of the brake pedal bias. The balance bar can be set and locked down with the jam nut, or attached to a remote cable for quick on-track adjustments. This assembly creates a 6.25 to 1 pedal ratio on both clutch and brake pedals.

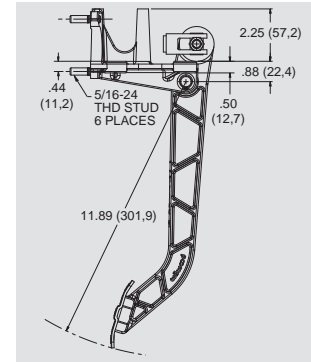

Pedal Ordering Information

DESCRIPTION	PART NUMBER
Adjustable Reverse Mount Triple Master Cylinder Pedal Assembly, 6.25:1 Ratio	340-11299 ⁽¹⁾

Adjustable Reverse Swing Mount Dual Master Cylinder Pedal - Aluminum

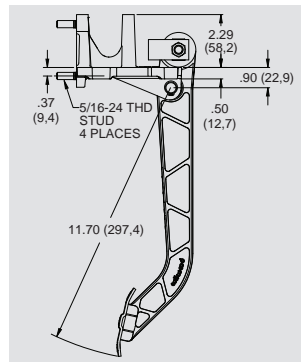

Wilwood's new adjustable reverse mount pedal assembly mounts two brake master cylinders with a bias balance bar and positions the master cylinders inside the firewall and away from engine heat. It features all aluminum frame and forged aluminum pedal arm with ladder style construction. The pedal pad is a special adjustable design that allows fine-tuning of the pedal location and clearance. Wilwood's clevis and pivot pin balance bar provide smooth and accurate settings of the brake pedal bias. It can be set and locked down with the jam nut, or attached to a remote cable for quick on-track adjustments. 6.25 to 1 ratio is offered in this unit to suit your mounting and leverage requirements

Pedal Ordering Information

DESCRIPTION	PART NUMBER
Adjustable Reverse Mount Dual Master Cylinder Pedal Assembly, 6.25:1 Ratio	340-12509 ⁽¹⁾

Adjustable Pedal Retrofit Kit

These retrofit kits will upgrade your existing forward (near right photo) or reverse (far right photo) swing mount triple master cylinder pedal assemblies to our new adjustable style without having to replace the complete pedal assembly. Installation is quick and simple.



Pedal Ordering Information

DESCRIPTION	PART NUMBER
Adjustable Forward Mount Triple Master Cylinder Pedal Retrofit Kit, 6.25:1	340-12043
Adjustable Reverse Mount Triple Master Cylinder Pedal Retrofit Kit, 6.25:1	340-12044

NOTES:

(1) Pedals are shown with optional master cylinders which must be ordered separately. See pages 59-61 for available selections.

Pedal Assemblies

Floor Mount Single Master Cylinder Pedal - Brake or Clutch

This pedal is often used as a clutch pedal with a single outlet master cylinder, or as a brake pedal in conjunction with dual outlet, tandem master cylinders on four wheel brake equipped vehicles. The pedal features all aluminum frame and arm construction with steel pivots, mounting studs, and an anti-skid pedal pad. This pedal is designed to be mounted to the floor, and creates a 6.00:1 ratio.

Pedal can be adapted to use tandem master cylinder with horizontal mounting, use adapter 250-3677.

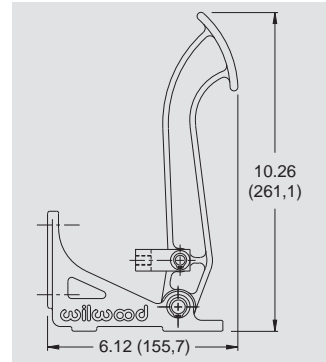

Pedal Ordering Information

DESCRIPTION	PART NUMBER
Single Mount Brake or Clutch Pedal Assembly, 6:1 Ratio	340-1289 ⁽¹⁾

Floor Mount Dual Master Cylinder Brake Pedal with Balance Bar

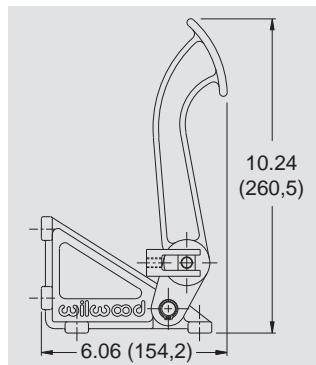

This is one of racing's most popular pedals for floor mounting two brake master cylinders with a bias balance bar. The pedal features all aluminum frame and arm construction with steel pivots, mounting studs, and an anti-skid pedal pad. Wilwood's clevis and pivot pin balance bar provide smooth and accurate settings of the brake pedal bias. It can be set and locked down with the jam nut, or attached to a remote cable for quick on-track adjustments. Pedal assembly creates a 6.00:1 pedal ratio.

Pedal Ordering Information

DESCRIPTION	PART NUMBER
Dual Mount Brake Pedal with Balance Bar Pedal Assembly, 6:1 Ratio	340-1285 ⁽¹⁾

Forward Swing Mount Single Master Cylinder Pedal - Brake or Clutch

This pedal is often used as a clutch pedal with a single outlet master cylinder, or as a brake pedal in conjunction with dual outlet, tandem master cylinders on four wheel brake equipped vehicles. The pedal features all aluminum frame and arm construction with steel pivots, mounting studs, and an anti-skid pedal pad. This pedal is designed to be mounted to the top of the foot box, and creates a 7.00:1 ratio.

Pedal can be adapted to use tandem master cylinder with horizontal mounting, use adapter 250-3677.

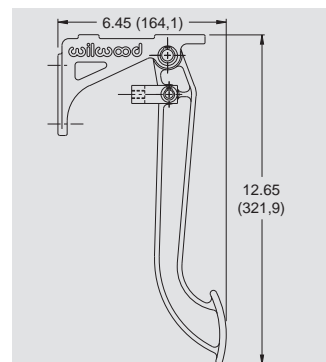

Pedal Ordering Information

DESCRIPTION	PART NUMBER
Single Mount Brake or Clutch Pedal Assembly, 7:1 Ratio	340-1290 ⁽¹⁾

NOTES:

(1) Pedals are shown with optional master cylinders which must be ordered separately. See pages 59-61 for available selections.

Pedal Assemblies

Forward Swing Mount Dual Master Cylinder Brake Pedal with Balance Bar

This is one of racing's most popular pedals for swing mounting two brake master cylinders with a bias balance bar. The pedal features all aluminum frame and arm construction with steel pivots, mounting studs, and an anti-skid pedal pad. Wilwood's clevis and pivot pin balance bar provide smooth and accurate settings of the brake pedal bias. It can be set and locked down with the jam nut, or attached to a remote cable for quick on-track adjustments. Pedal assembly creates a 7.00:1 pedal ratio.

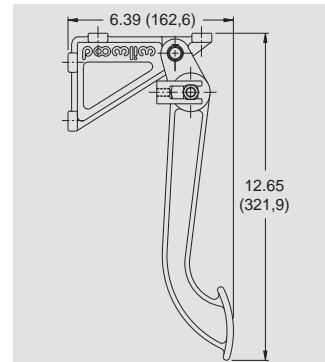

Pedal Ordering Information

DESCRIPTION	PART NUMBER
Dual Mount Brake Pedal with Balance Bar Pedal Assembly, 7:1 Ratio	340-1287 ⁽¹⁾

Forward Swing Mount Triple Master Cylinder Clutch & Brake Pedal with Balance Bar - Aluminum

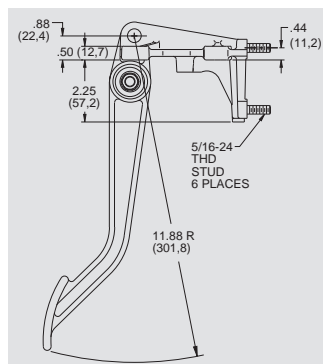

This pedal assembly operates the brakes and the clutch together in one unit and positions the master cylinders outside of the firewall. It features all aluminum frame and arm construction with steel pivots, mounting studs, and anti-skid pedal pads. Wilwood's clevis and pivot pin balance bar provide smooth and accurate settings of the brake pedal bias. It can be set and locked down with the jam nut, or attached to a remote cable for quick on-track adjustments. Pedal assembly creates a 6.25:1 pedal ratio.

Pedal Ordering Information

DESCRIPTION	PART NUMBER
Triple Mount Brake and Clutch Pedal Assembly with Balance Bar, 6.25:1 Ratio	340-3950 ⁽¹⁾

Reverse Swing Mount Dual Master Cylinder Brake Pedal with Balance Bar

This pedal mounts two brake master cylinders with a bias balance bar and positions the master cylinders inside the firewall and away from engine heat. The pedal features all aluminum frame and arm construction with steel pivots, mounting studs, and an anti-skid pedal pad. Wilwood's clevis and pivot pin balance bar provide smooth and accurate settings of the brake pedal bias. It can be set and locked down with the jam nut, or attached to a remote cable for quick on-track adjustments. 5.00 to 1 or 6.25 to 1 ratios are offered in this unit to suit your mounting and leverage requirements.

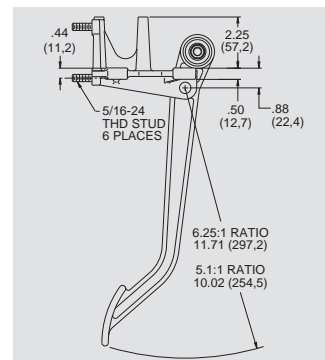

Pedal Ordering Information

DESCRIPTION	PART NUMBER
Reverse Dual Mount Brake Pedal with Balance Bar Pedal Assembly, 5.1:1 Ratio	340-5180 ⁽¹⁾
Reverse Dual Mount Brake Pedal with Balance Bar Pedal Assembly, 6.25:1 Ratio	340-5181 ⁽¹⁾

NOTES:

(1) Pedals are shown with optional master cylinders which must be ordered separately. See pages 59-61 for available selections.

Pedals Assemblies

Reverse Swing Mount Triple Master Cylinder Clutch & Brake Pedal with Balance Bar

This assembly combines the brake and clutch pedals together in one unit and positions the master cylinders inside the firewall and away from engine heat. It features all aluminum frame and arm construction with steel pivots, mounting studs, and anti-skid pedal pads. Wilwood's clevis and pivot pin balance bar provide smooth and accurate settings of the brake pedal bias. It can be set and locked down with the jam nut, or attached to a remote cable for quick on-track adjustments. Pedal is available with three different ratio combinations to choose from.

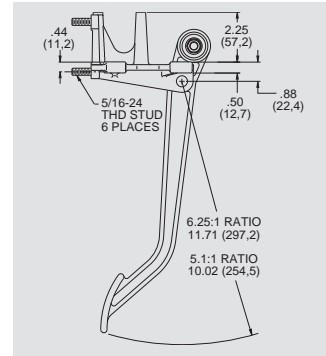

Pedal Ordering Information

DESCRIPTION	PART NUMBER
Triple Mount Clutch and Brake Pedal Assembly with Balance Bar, 5:1:1 Ratio	340-4828 ⁽¹⁾
Triple Mount Clutch and Brake Pedal Assembly with Balance Bar, 6.25:1 Ratio	340-3342 ⁽¹⁾
Triple Mount Clutch and Brake Pedal Assembly with Balance Bar, 6.25:1 Brake Ratio, 5:1:1 Clutch Ratio	340-6451 ⁽¹⁾

NOTES:

(1) Pedals are shown with optional master cylinders which must be ordered separately. See pages 59-61 for available selections.

Clutch Pedal Kit - Floor Mount

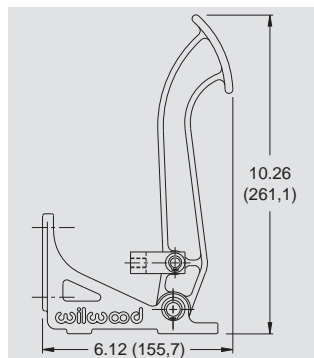

Wilwood's clutch pedal kit comes with a floor mount clutch pedal of 6:1 ratio, .750" bore master cylinder with Integral reservoir and universal pull type slave cylinder.

Pedal kit, contains Wilwood's 260-1304 master cylinder and 260-1333 slave cylinder.

Ordering Information

DESCRIPTION	PART NUMBER
Clutch Pedal Kit, Floor Mount 6:1 Ratio	340-1469

Clutch Pedal Kit - Swing Mount

Wilwood's clutch pedal kit comes with a swing mount clutch pedal of 7:1 ratio, .750" bore master cylinder with Integral reservoir and universal pull type slave cylinder.

Pedal kit, contains Wilwood's 260-1304 master cylinder and 260-1333 Slave cylinder.

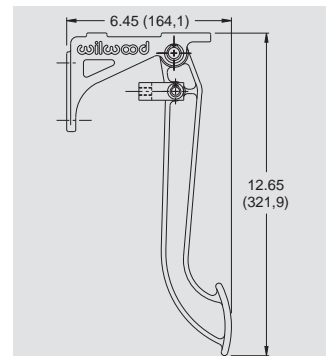

Ordering Information

DESCRIPTION	PART NUMBER
Clutch Pedal Kit, Swing Mount 7:1 Ratio	340-1470

Pedal Assemblies

60 Degree Balance Pedal Assembly

This lightweight unit is ideal for Dirt Modifieds, Champ Cars, Sprint Cars and Midgets where master cylinders must be mounted in a remote location because of tight space constraints. Usually mounted to the driver's left side chassis rail, the unit's balance bar controls two standard mount master cylinders with remote mounted reservoirs. The 60 degree mounting angle allows for tight fit applications and easy accessibility. Strong cast aluminum housing and balance bar weighs only 1.8 pounds. An adjuster knob is included with each assembly.

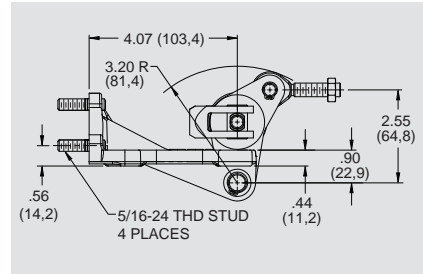

Pedal Ordering Information

DESCRIPTION	PART NUMBER
60 Degree Balance Bar Pedal Assembly, 1.48:1 Ratio	340-4630 ^(1,2)

NOTES:

- (1) Pedals are shown with optional master cylinders which must be ordered separately. See pages 59-61 for available selections.
- (2) Special pedal application for asphalt sprints and modifieds. Base and balance bar only. Does not include pedal assembly.

Balance Bar Assembly



Wilwood's balance bar assembly is designed to maximize travel and adjustability providing increased front-to-rear bias control. The precision spherical bearing with corrosion resistant finish is durable and smooth performing. The 3/8-24 threaded adjuster bar is high strength aircraft alloy and fitted with lightweight, maintenance free clevises and thrust washers to eliminate binding under extreme pivot angles.

Ordering Information

DESCRIPTION	PART NUMBER
Balance Bar with Steel Sleeve for Easy Weld on Operation to Fabricated Steel Pedal Assemblies	340-1757
Replacement Balance Bar Assembly with Clevises and Bearing for all Wilwood Pedals with Balance Bars	340-4745

Remote Brake Bias Adjuster

Wilwood's remote balance bar cable adjuster is used with balance bars to adjust front-to-rear brake bias during changing race conditions. The highly visible bright blue knob features a special bi-directional detent control providing the driver with positive adjustment feedback. The special five foot cable and housing (which can be cut to any length for a custom fit) provides an optimum bending radius for easy installation and smooth performance in tight confines. The assembly comes with two label faces for either front-to-rear or rear-to-front adjustment. Standard 3/8-24 thread fits Wilwood and most commonly used balance bars.



Ordering Information

DESCRIPTION	PART NUMBER
Remote Brake Bias Adjuster	340-4990

Pedals Assemblies

Brake Pedal Guidelines

Wilwood pedal assemblies and integrated balance bars have been designed specifically for racing applications. Properly set-up, this assembly will allow for the precise adjustment of front-to-rear brake bias. The advantages of an adjustable balance bar and dual master cylinders are:

- Brake proportioning can be adjusted by use of different size master cylinder bores for front and rear brakes.
- Front to rear brake balance can be fine tuned by adjusting the balance bar.
- With two independent hydraulic systems, should one master cylinder fail, the other system may remain functional.

Brake pedals should be mounted securely. When possible, keep the master cylinder reservoir level higher than the horizontal plane of the calipers to prevent excessive fluid drain back which can result in double pumping of the pedal. If this is not possible, a two pound residual pressure valve should be plumbed into the brake line at the exit of the master cylinder to prevent fluid drain back (do not confuse the two pound valve with the ten pound version; the ten pound valve is for use with drum brakes only).

Brake pedals should be free to return when no pressure is being applied, allowing the master cylinder pushrod to return to its undepressed position. In some cases, the master cylinder spring (internal) may not be strong enough to fully return the pushrod; in this case an additional pedal return spring can be used. There are two important items for consideration:

1. The brake pedal should have an adjustable return stop on it when a strong pedal return spring is used. This prevents the master cylinder from excessively banging the snap ring stop inside the master cylinder bore (visible under the rubber boot). Adjust the stop so the pedal stops returning at the point when the master cylinder piston retracts against the snap ring, Figure 1, above.
2. The master cylinder piston must fully retract. If the master cylinder piston is not allowed to fully retract when the brake pedal is not applied, the primary inside seal will not return past the small pressure relief hole (visible within the master cylinder reservoir on some master cylinders). This can cause excessive residual line pressure and contribute to brake drag and an overheating condition, see Figure 1, Detail "A", above.

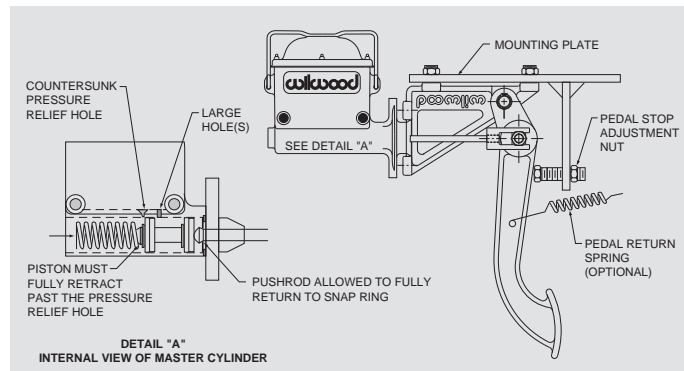

Figure 1. Master cylinder pedal stop and return hole position

Balance Bar Adjusting

The balance bar is an adjustable lever (usually a threaded rod), that pivots on a spherical bearing and uses two separate master cylinders for the front and rear brakes. Most balance bars are part of a pedal assembly that also provides a mounting for the master cylinders. When the balance bar is centered, it pushes equally on both master cylinders creating equal pressure, given that the master cylinders are the same size bore. When adjusted as far as possible toward one master cylinder it will push approximately twice as hard on that cylinder as the other.

To set up the balance bar, thread the master cylinder pushrods through their respective clevises to obtain the desired position. Threading one pushrod into its respective clevis means threading the other one out the same amount. Sometimes this will lead to a "cocked" balance bar when the pedal is in the relaxed position, see Figure 2, right, "no pedal effort". This is acceptable as long as each master cylinder pushrod is completely free of pressure when the pedal is relaxed.

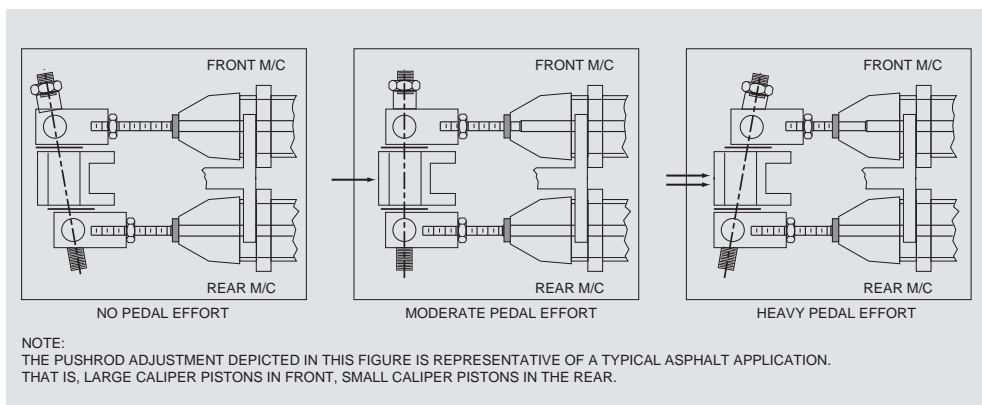

Figure 2. Balance bar lever adjustment

Pedal Assemblies

Balance Bar Adjusting

It is **important** that the operation of the balance bar functions without interference by over adjustment. This can occur when a clevis jams against the side of the pedal or the lever (bolt) hits the pedal bore during any point of pedal travel, see Figure 3, right.

Lever movement should be unimpeded throughout pedal travel. In the neutral position, clevises should have between .20" - .25" total clearance between the side of the pedal. The large washers between the pedal and clevis should remain loose. Make sure that the master cylinder pushrods remain true in relationship to the cylinder during entire pedal travel; pushrods should not be pushing master cylinder pistons at an angle. See Figure 4, right.

NOTE: In its non-depressed position, the pedal and balance bar should allow the pushrod of the master cylinders to fully return. This can be checked by feeling pushrods for very *slight* movement, not loose movement. Master cylinder pistons should be against the retaining snap ring (under boot).

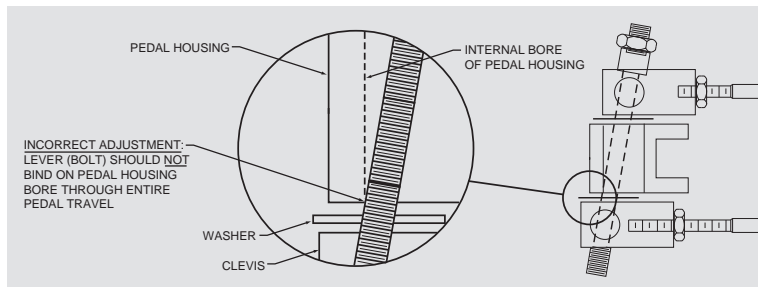

Figure 3. Balance bar lever interference

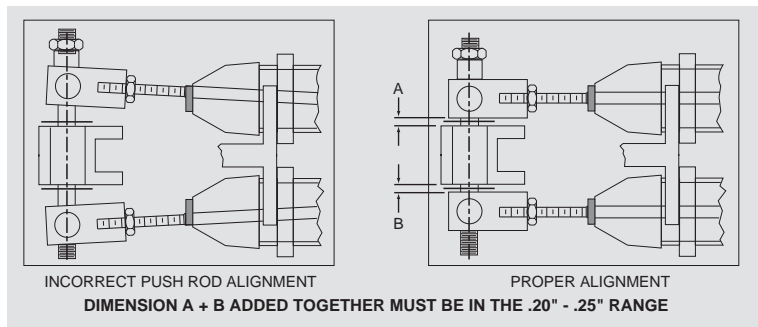

Figure 4. Example of pushrod alignment

Pedal Ratios / Mechanical Leverage

Pedal ratio, or mechanical leverage is the ratio calculated from the length from the pivot point of the pedal to the center of the foot pedal (A), divided by the length from the pivot point to the master cylinder pushrod (B). Refer to the figures below.

Mechanical leverage is simply a means of increasing the brake force without increasing your leg effort. As "A" gets longer and "B" gets shorter, the mechanical leverage increases brake force without pushing harder on the pedal. The disadvantage is that the pedal stroke also increases, requiring you to push the pedal further.

With a 1 inch master cylinder stroke, a 100 pound push on the pedal, and the pedal having a 4:1 ratio, the force is $4 \times 100 = 400$ pounds, and the stroke is $4 \times 1 = 4$ inches. With a 100 pound push on the pedal, and the pedal having a 6:1 ratio, the force is $6 \times 100 = 600$ pounds, and the stroke is $6 \times 1 = 6$ inches.

If uncertain about which pedal ratio is right for your application, a 6:1 ratio is an excellent starting point.



Figure 1

Figure 2

Figure 3

Figure 4

A = Distance from pivot point to middle of push / pull point
 B = Distance from pivot to point of push on master cylinder
 P = Pivot point
 F = Force or push

Proportioning Valves

Knob Style Proportioning Valve

Valve features an adjustable knee point from 100 to 1000 PSI. The proportioning rate is 57% from the desired knee point onward. Adjuster knob with fine thread tuning provides precise adjustment. This adjustment lets you fine tune the front to rear braking balance by proportionally decreasing the rear brake line pressure. Valve weighs only 5.2 ounces and has two .25" side mounting holes spaced 1.00" apart. Available in standard 1/8-27 NPT in/out ports, M10 x 1 BF, or 3/8-24 IF.

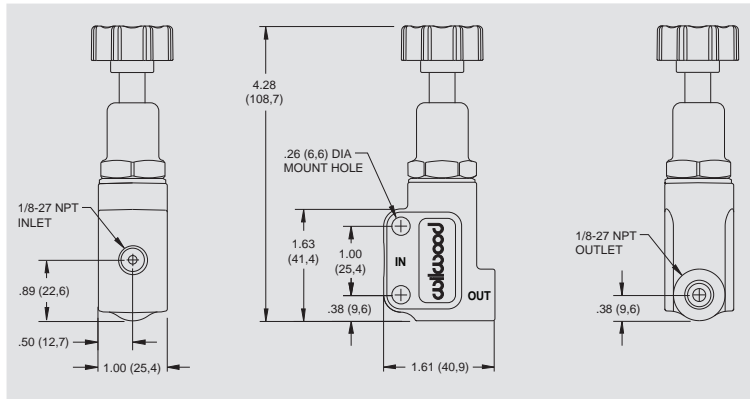

Ordering Information

DESCRIPTION	PART NUMBER
Knob Style Proportioning Valve with 1/8-27 NPT Inlets - Comes with Tube Nut Adapters for Installation of 3/8" Tubing	260-8419
Knob Style Proportioning Valve with 3/8-24 Inverted Flare Seats for Direct Installation to 3/8" Tubing with 3/8-24 Nuts	260-10922
Knob Style Proportioning Valve with M10 x 1 BF inlet and outlet	260-12627

Lever Style Proportioning Valve

Valve features an adjustable knee point from 100 to 1000 PSI. The proportioning rate is 57% from the desired knee point onward. This proportioning valve has six preset points actuated by moving a lever allowing racers to quickly adjust brake bias during a race. The lever "clicks" into the six positions for positive adjustment. Valves weigh only 6.1 ounces, and have two .25" side mounting holes spaced 1.00" apart. Inlet / outlet ports are 1/8-27 NPT.

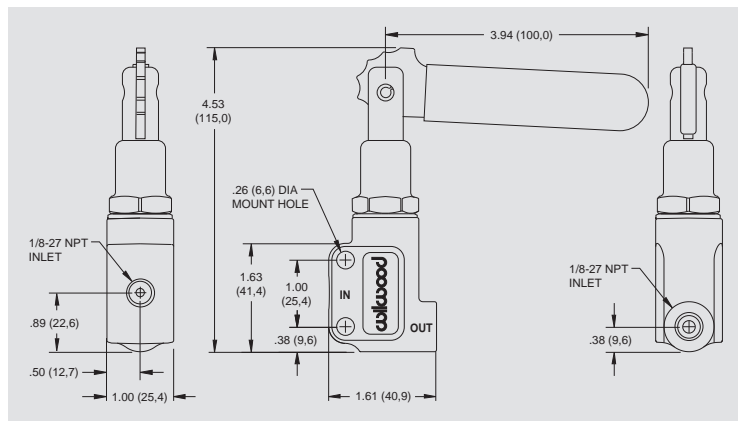

Ordering Information

DESCRIPTION	PART NUMBER
Lever Style Proportioning Valve with 1/8-27 NPT Inlets - Comes with Tube Nut Adapters for Installation of 3/8" Tubing	260-8420

Proportioning Valves

Knob Style Combination Proportioning Valve

This valve simplifies mounting, plumbing, wiring and brake proportioning adjustments on vehicles with custom brake systems. The combination block maintains full isolation between front and rear fluid circuits and can be used in conjunction with any tandem outlet or dual mount master cylinder assemblies. The rear circuit has a single inlet and single outlet with the adjustable proportioning valve. The front circuit has a single inlet with two outlets. It can be run as a single outlet with one outlet plugged, or used to split the plumbing on its way to the front calipers.

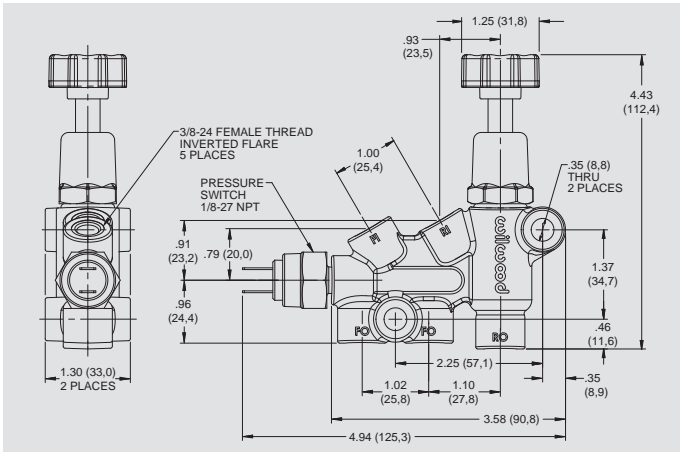

Ordering Information

DESCRIPTION	PART NUMBER
Combination Style Proportioning Valve	260-11179

GM Style Proportioning Valve

Wilwood's GM style proportioning valve is a direct replacement for 1978 and newer GM style vehicles equipped with front disc/rear drum brakes. Line connections for the valve, if mounted in the OE location, will allow the original lines to connect directly to the valve. If mounted in a non-OE location, fluid lines may have to be modified. This also does allow usage in other non-GM vehicles. This proportioning valve offers: 63% pressure reduction (rear) after the fixed 350 PSI knee point, 30 PSI front circuit delay and circuit failure sender activation at 50 PSI. Recommended maximum operating pressure: 2000 PSI. Non-adjustable front-to-rear proportioning (knee point, rate, etc.). Anti-dive or metering delay valve: Enables rear brake pressure to build momentarily before front brake pressure builds.

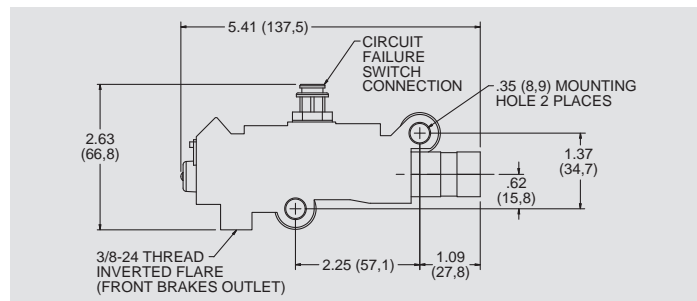

Ordering Information

DESCRIPTION	PART NUMBER
Wilwood GM Style Proportioning Valve	260-11322

Line Shut-Off Valve

WARNING • NOT A LINE LOCK • NOT FOR STREET USE

THIS DEVICE IS INTENDED FOR SPECIALIZED RACING USE ONLY. READ INSTRUCTIONS AND ALL WARNINGS CAREFULLY. INSTALLATION OF THIS COMPONENT SHOULD **ONLY** BE PERFORMED BY PERSONS EXPERIENCED IN THE INSTALLATION AND PROPER OPERATION OF DISC BRAKE SYSTEMS. IT IS THE RESPONSIBILITY OF THE PERSON INSTALLING ANY BRAKE COMPONENT OR KIT TO DETERMINE THE SUITABILITY OF THE COMPONENT OR KIT FOR THAT PARTICULAR APPLICATION.

RACING EQUIPMENT AND BRAKES MUST BE MAINTAINED AND SHOULD BE CHECKED REGULARLY FOR FATIGUE, DAMAGE AND WEAR.

Wilwood Line Shut-Off Valve

This valve is used as a brake shut-off. When energized, the valve will block pressure from reaching the caliper. The valve does not prevent fluid from returning to the master cylinder. This eliminates the possibility of trapping pressure when activating the valve. Requires a 12 Volt, 5 amp (recommended) fused power source through a toggle switch. **Warning:** Not a line lock assembly. **NOT** for street use. Please read instruction sheet available at <http://www.wilwood.com/pdf/ds572.pdf> before attempting installation.

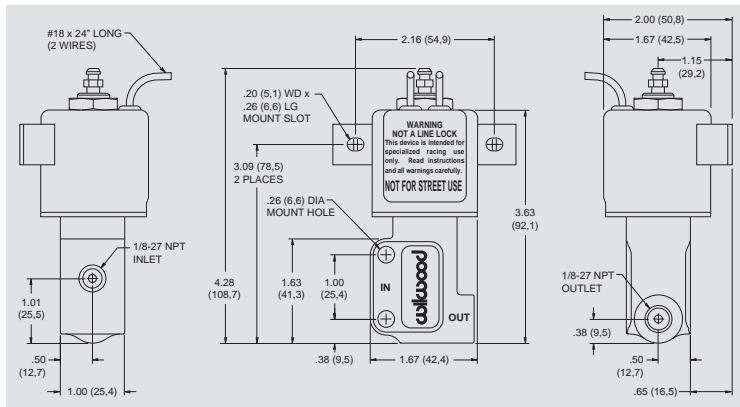

FOR OFF ROAD USE ONLY

BEFORE OPERATING VEHICLE, TEST THE BRAKES UNDER CONTROLLED CONDITIONS. MAKE SEVERAL STOPS IN A SAFE AREA FROM LOW SPEEDS AND ONLY GRADUALLY WORK UP TO HIGHER SPEEDS. **DO NOT RACE ON UNTESTED BRAKES! ALWAYS UTILIZE SAFETY RESTRAINT SYSTEMS WHILE OPERATING VEHICLE.**

IMPORTANT: READ DISCLAIMER OF WARRANTY INCLUDED WITH THE COMPONENTS.

Ordering Information

DESCRIPTION	PART NUMBER
Wilwood Line Shut-Off Valve	260-9921

Quick Check Pressure Gauge



This easy to read two inch diameter non-hazing face allows for quick brake line pressure checks from 0-1,500 PSI (or 0-10,000 kPa). 20 PSI graduations and accuracy to 1.5% permit reliable brake bias setup and brake system troubleshooting. It is durable and corrosion resistant.

Ordering Information

DESCRIPTION	PART NUMBER
Quick Check Pressure Gauge	260-0966
Quick Check Pressure Gauge Fitting Adapter to Caliper	220-0971

Master Cylinders

Compact Combination Remote Master Cylinder Kit - Side Mount

Wilwood's compact combination master cylinders have been designed for limited space applications requiring the output capacity of a full size master cylinder. The ultra short 3.37" compact body provides 2.16" of additional clearance compared to previous remote reservoir master cylinders. A full 1.12" of piston stroke meets or exceeds the stroke capacity of most full size cylinders. With 1/8" NPT fluid outlet port located at the top radius of the cylinder bore, reduces the chances for trapped air. The black E-Coated aluminum body resists corrosion and maintains a durable long lasting finish.

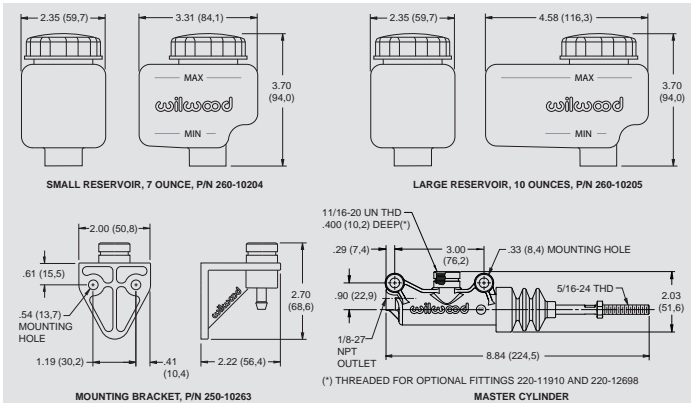

Ordering Information

DESCRIPTION	PART NUMBER	DESCRIPTION	PART NUMBER
5/8" Combination Master Cylinder Kit (1.2 stroke)	260-12384	Rebuild Kit, 5/8" Combination	260-10513
3/4" Combination Master Cylinder Kit (1.2 stroke)	260-12385	Rebuild Kit, 3/4" Combination	260-10514
13/16" Combination Master Cylinder Kit (1.2 stroke)	260-12386	Rebuild Kit, 13/16" Combination	260-10515
7/8" Combination Master Cylinder Kit (1.2 stroke)	260-12387	Rebuild Kit, 7/8" Combination	260-10516
1" Combination Master Cylinder Kit (1.2 stroke)	260-12388	Rebuild Kit, 1" Combination	260-10517
1-1/8" Combination Master Cylinder Kit (1.2 stroke)	260-12389	Rebuild Kit, 1-1/8" Combination	260-10518
Remote Reservoir Hose, 1/4" I.D. x 30" Long	220-10444	Remote Reservoir Hose, by the Inch	220-10414

Compact Combination Remote Master Cylinder Kit - Flange Mount

These compact combination master cylinders have the same attributes as mentioned above except in the standard flange mounting bolt hole configuration.

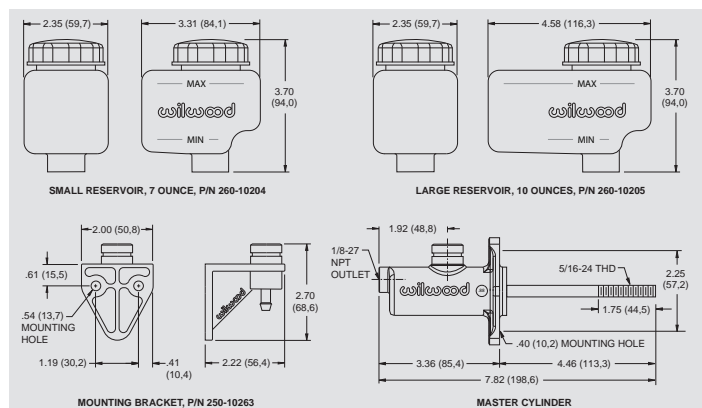

Ordering Information

DESCRIPTION	PART NUMBER	DESCRIPTION	PART NUMBER
5/8" Combination Master Cylinder Kit (1.2 stroke)	260-10371	Rebuild Kit, 5/8" Combination	260-10513
3/4" Combination Master Cylinder Kit (1.2 stroke)	260-10372	Rebuild Kit, 3/4" Combination	260-10514
13/16" Combination Master Cylinder Kit (1.2 stroke)	260-10373	Rebuild Kit, 13/16" Combination	260-10515
7/8" Combination Master Cylinder Kit (1.2 stroke)	260-10374	Rebuild Kit, 7/8" Combination	260-10516
1" Combination Master Cylinder Kit (1.2 stroke)	260-10375	Rebuild Kit, 1" Combination	260-10517
1-1/8" Combination Master Cylinder Kit (1.2 stroke)	260-10376	Rebuild Kit, 1-1/8" Combination	260-10518
Remote Reservoir Hose, 1/4" I.D. x 30" Long	220-10444	Remote Reservoir Hose, by the Inch	220-10414

Master Cylinders

Combination Remote Master Cylinder Kit

Combination remote master cylinders offer six different bore sizes and four different installation configurations that are available with this master cylinder kit. Precision machined from high strength aluminum, this kit includes both small and large size reservoirs which can be mounted directly on the master cylinder or remotely mounted for more convenient service access. Standard mounting bolt hole configurations make this kit applicable to a multitude of applications.

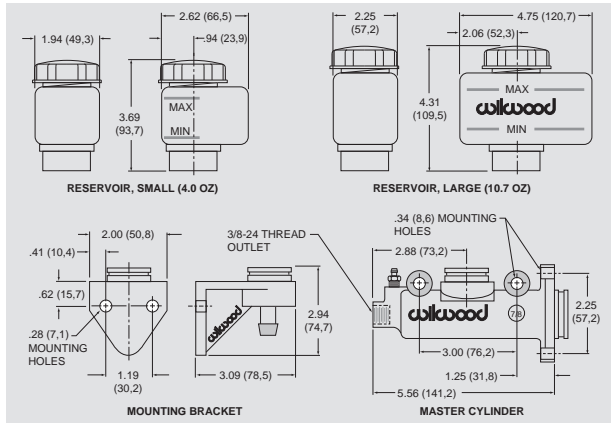

Ordering Information

DESCRIPTION	PART NUMBER	DESCRIPTION	PART NUMBER
5/8" Combination Master Cylinder Kit (1.2 stroke)	260-3372	Rebuild Kit, 5/8" Combination	260-3880
3/4" Combination Master Cylinder Kit (1.2 stroke)	260-3374	Rebuild Kit, 3/4" Combination	260-3881
13/16" Combination Master Cylinder Kit (1.2 stroke)	260-5920	Rebuild Kit, 13/16" Combination	260-5921
7/8" Combination Master Cylinder Kit (1.2 stroke)	260-3376	Rebuild Kit, 7/8" Combination	260-3882
1" Combination Master Cylinder Kit (1.2 stroke)	260-3378	Rebuild Kit, 1" Combination	260-3883
1-1/8" Combination Master Cylinder Kit (1.2 stroke)	260-3380	Rebuild Kit, 1-1/8" Combination	260-3884
7/8" Master Cylinder (1.2 stroke) with 4 ounce reservoir ⁽¹⁾	260-12114	Push Rod	230-6171
1" Master Cylinder (1.2 stroke) with 4 ounce reservoir ⁽¹⁾	260-12115	Cap, Master Cylinder, Plastic w/Seal	330-4355
Remote Reservoir Hose, 3/8" I.D. x 30" Long	220-3357	Remote Reservoir Hose, by the Inch	220-5613

NOTES: (1) These part numbers contain only the master cylinder with o-ring, 4 ounce reservoir with clamp and screw on lid.

High Volume Aluminum Master Cylinder

Wilwood high-volume aluminum master cylinders feature high pressure die-cast bodies made from premium grade aluminum. These high-volume master cylinders have the largest fluid capacity of any integral reservoir design. With a total capacity of 8.2 ounces, there is at least 26% more fluid volume than other brands. With 1.43" of piston travel, it offers extra margin when used with large piston calipers. Heavy duty internal springs provide fast retraction. Formed steel lids with bellows type gaskets keep the fluid in and the moisture out. Wilwood master cylinders use common dimensions for flange or side mounting and a 1/8-27 NPT outlet port.

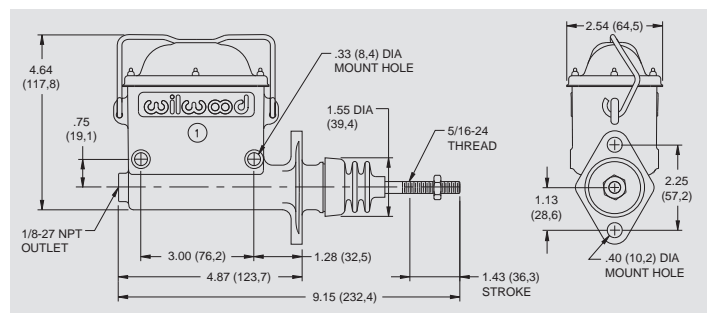

Ordering Information

DESCRIPTION	PART NUMBER	DESCRIPTION	PART NUMBER
3/4" Bore High-Volume Aluminum Master Cylinder	260-6764	Rebuild kit - 3/4" bore	260-6898
7/8" Bore High-Volume Aluminum Master Cylinder	260-6765	Rebuild kit - 7/8" bore	260-6899
1" Bore High-Volume Aluminum Master Cylinder	260-6766	Rebuild kit - 1" bore	260-6900
Lid with Gasket	330-7085	Gasket	210-6725
Lid Bail Wire	300-6726		

Master Cylinders

Detached Reservoir Compact Aluminum Master Cylinder

Remote reservoir compact master cylinders are the perfect solution where there is limited space for the master cylinder and fluid reservoir. These aluminum cylinders are designed for use with either a detachable or remote fill reservoirs. Available in four bore sizes from .625" to .813", with a full 1.4" stroke to accommodate short pedal ratios, small brake calipers, and hydraulic clutch actuation. Reservoir kits with fittings are available under part number's 260-7577 (4.0 oz.) or 260-8742 (10.7 oz)

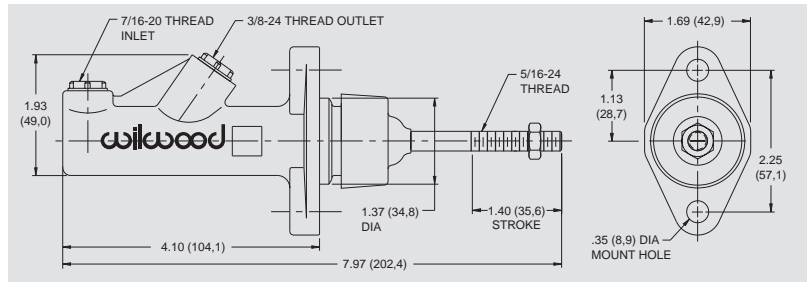

Ordering Information

DESCRIPTION	PART NUMBER
.625" Bore Remote Master Cylinder	260-6087
.700" Bore Remote Master Cylinder	260-6088
.750" Bore Remote Master Cylinder	260-6089
.813" Bore Remote Master Cylinder	260-11972
Reservoir Kit (shown inset), Compact Remote (small 4.0 oz)	260-7577
Reservoir Kit (shown inset), Compact Remote (large 10.7 oz)	260-8742

Integral Reservoir Compact Aluminum Master Cylinder

Remote reservoir compact master cylinders are the perfect solution where there is limited space for the master cylinder and fluid reservoir. Available in three bore sizes from .625" to .750", with a full 1.4" stroke to accommodate short pedal ratios, small brake calipers, and hydraulic clutch actuation.

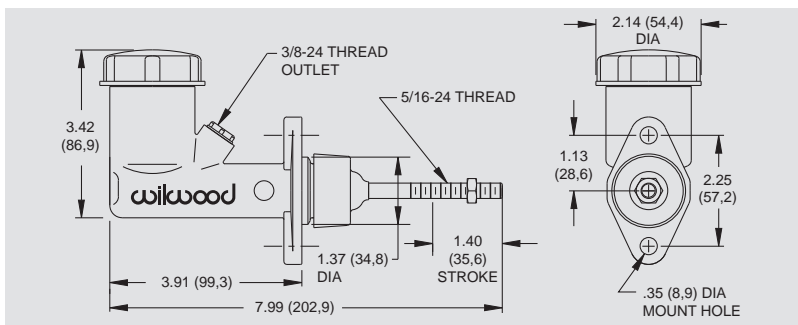

Ordering Information

DESCRIPTION	PART NUMBER
.625" Bore Aluminum Master Cylinder	260-2636
.700" Bore Aluminum Master Cylinder	260-6579
.750" Bore Aluminum Master Cylinder	260-1304
Cap with Baffle	330-4355
Cap with Diaphragm	330-7640

Master Cylinders

Aluminum Tandem Chamber Master Cylinder

Wilwood's tandem chamber master cylinders are fully machined from a high-pressure die casting of a premium aluminum alloy. It incorporates a slotted mounting flange to accommodate mount centers between 3.22" to 3.40" and also features side-hole mounts on 6.40" centers. Master cylinder has full separation between the front and rear chambers. Dual outlets allow for right or left hand plumbing based on mount location. Offers a total piston stroke of 1.10" and a 2:1 volume ratio between the primary and secondary chambers. Available in 7/8", 1" or 1-1/8" bore sizes. Available in three finishes.

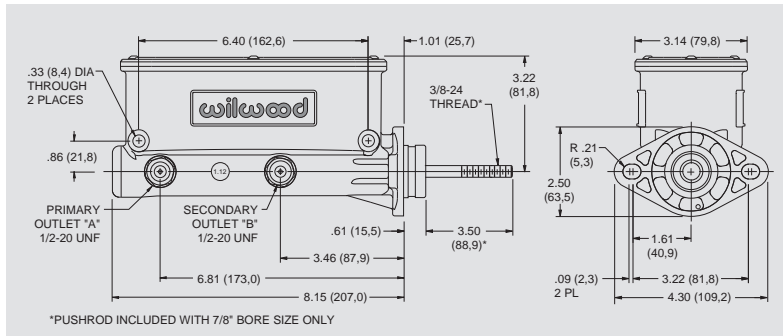

Ordering Information

DESCRIPTION	PART NUMBER
7/8" Bore Master Cylinder with Push Rod - Standard Finish	260-9439
7/8" Bore Master Cylinder with Push Rod - Black Finish	260-9439-BK
7/8" Bore Master Cylinder with Push Rod - Bright Finish	260-9439-P
1" Bore Master Cylinder without Push Rod - Standard Finish	260-8555
1" Bore Master Cylinder without Push Rod - Black Finish	260-8555-BK
1" Bore Master Cylinder without Push Rod - Bright Finish	260-8555-P
1-1/8" Bore Master Cylinder without Push Rod - Standard Finish	260-8556
1-1/8" Bore Master Cylinder without Push Rod - Black Finish	260-8556-BK
1-1/8" Bore Master Cylinder without Push Rod - Bright Finish	260-8556-P

Master Cylinder Bleeding Kit



This master cylinder bleeding kit makes bench bleeding your master cylinder a snap. Includes various size adapters for virtually every application along with two clear bleeder tubes. Kit can be used on tandem as well as single reservoir master cylinders. Bench bleeding is necessary to assure that the system is completely bled and free from trapped air.

Ordering Information

DESCRIPTION	PART NUMBER
Wilwood Master Cylinder Bleeding Kit	260-11593

Master Cylinders

Tandem Master Cylinder

Made from durable lightweight aluminum with a large capacity plastic reservoir and dual outlet bores, this master cylinder utilizes standard O.E.M. internal components. Standard factory mounting bolt holes can be adapted to racing pedal assemblies with an optional mounting adapter bracket (including push rod and dust boot, see diagram below). This lightweight (2.5 pounds) reliable master cylinder is used for Drag Racing, Late Model Stock Cars, Street Rod, and Off Road applications.

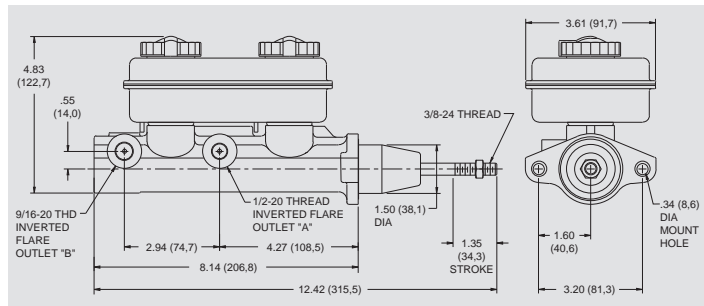

Ordering Information

DESCRIPTION	PART NUMBER
1-1/16" Tandem Master Cylinder Only	260-4893
1-1/16" Tandem Master Cylinder Kit (includes master cylinder, push rod, retainer and boot)	260-4894
Tandem Master Cylinder Rebuild Kit (1-1/16" bore)	260-4896
Universal Bracket Kit (tandem master cylinder to fire wall)	250-2406
Bracket Adapter Kit (tandem master cylinder to single brake pedal)	250-3677
Replacement Tube Adapter Fitting (3/16" x 1/2-20)	220-5247
Replacement Tube Adapter Fitting (3/16" x 9/16-20)	220-5248

Combination Remote Tandem Master Cylinder

Wilwood's remote tandem master cylinders provide one of the safest ways to actuate four wheel or dual caliper axle brake systems. The cylinder features 50/50 output from a 1.00" bore with 1.10" stroke. This master cylinder can be bolted directly to Wilwood's single mount pedals. The kit is shipped complete with the master cylinder, 5.00" x 5/16-24 pushrod, dust boot and all necessary hardware including 30 inches of hose that can be cut to the desired length for remote mounting of the two 4 ounce fluid reservoirs. Or order the assembled kit which includes the master cylinder with pre-installed 4 ounce reservoirs and 3.38" x 5/16-24 pushrod.

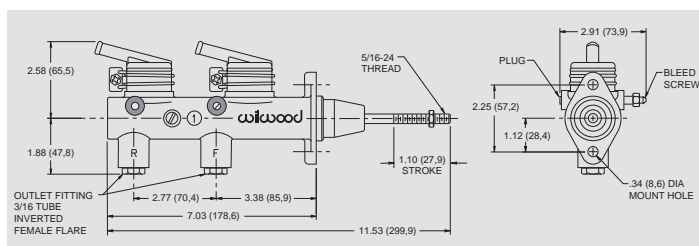

Ordering Information

DESCRIPTION	PART NUMBER
1.00" Bore Combination Remote Tandem Master Cylinder with Remote Fluid Reservoirs	260-7563
1.00" Bore Combination Remote Tandem Master Cylinder with Pre-Installed 4 Ounce Fluid Reservoirs	260-8794
Push Rod	230-6926

Master Cylinders

TM1 Tandem Master Cylinder

Manufactured from durable lightweight aluminum with dual outlet bores, this master cylinder utilizes standard Original Equipment Manufacturer (OEM) internal components. Standard factory mounting bolt holes can be adapted to racing pedal assemblies. This lightweight (less than one pound) reliable master cylinder and unique new design makes it a perfect fit for a wide range of applications. Compact design is perfect for applications where space is limited. Only 2.36" inches high with a body length of 6.00" (total including pushrod, 11.50") with a width of 1.80". Master cylinder comes ready to install with pushrod, clevis and dust boot. Compatible with DOT 3 and 4 brake fluids.

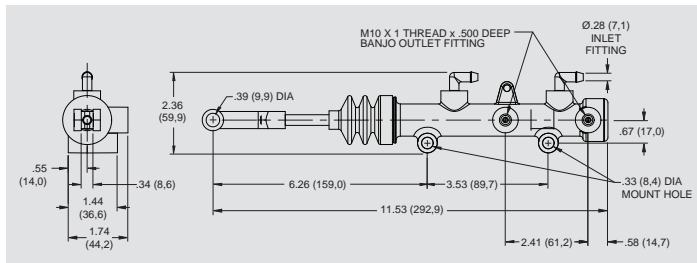

Ordering Information

DESCRIPTION	PART NUMBER
5/8" Bore Master Cylinder	260-11097
7 Ounce Remote Reservoir Kit with 30" of Hose (2 required per master cylinder)	260-11098

Kart / Jr. Dragster Master Cylinder

This super lightweight (only .55 pounds) 1/2" bore aluminum master cylinder designed specifically for Kart and Jr. Dragster racing applications incorporates an adjustable lever ratio with a remote mount clear fluid reservoir for easy monitoring. The assembly comes ready to install and includes billet bracket, lockwired drilled hardware and fluid line fitting. The unit is best utilized in conjunction with Wilwood's Kart / Jr. Dragster caliper (see page 18).

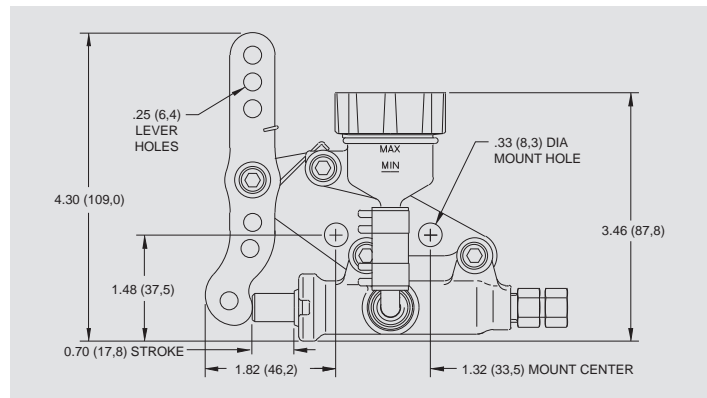

Ordering Information

DESCRIPTION	PART NUMBER	DESCRIPTION	PART NUMBER
Master Cylinder with Remote Mount Reservoir	260-5520	Replacement Cylinder Assembly	260-5516
Fitting, Straight, Brass, 1/8-27 NPT x 3/16"	220-5487	Hose, 1/4" I.D. x 1.15" Long	220-5534
Clamp, .50" Diameter	260-5556	Reservoir Assembly with Cap	330-4615
Cap Assembly	330-6014	Lever	330-5513

Master Cylinders

Handlebar Master Cylinder

Wilwood's 5/8" bore handlebar master cylinder is compact, lightweight and specifically designed for a variety of recreational, sport and outdoor equipment applications. Constructed of materials and finishes designed to resist corrosion, our master cylinder fits standard 7/8" diameter handlebars and is available either right or left hand. Impact resistant lever assembly comes with a three-position hydraulic parking brake lock. The housing is designed to accept a bayonet style brake light switch. The large capacity reservoir is translucent for easy fluid level viewing. The fluid inlet accepts an M10 x 1 thread banjo fitting.

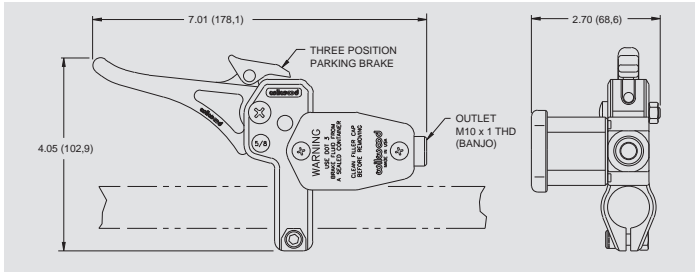

Ordering Information

DESCRIPTION	PART NUMBER
5/8" Bore Handlebar Master Cylinder, Single Outlet, Short Lever, Left Hand	260-4201
5/8" Bore Handlebar Master Cylinder, Single Outlet, Short Lever, Right Hand	260-4202

Handlebar Master Cylinder

Wilwood's 5/8" bore right hand handlebar master cylinder is compact, lightweight and specifically designed for a variety of recreational, sport and outdoor equipment applications. Constructed of materials and finishes designed to resist corrosion, our master cylinder fits standard 7/8" diameter handlebars and is available in both right or left hand configurations. Aluminum lever assembly comes with a three-position hydraulic parking brake lock. The housing is designed to accept a bayonet style brake light switch. The large capacity reservoir is translucent for easy fluid level viewing. The fluid inlet accepts an M10 x 1 thread banjo fitting.

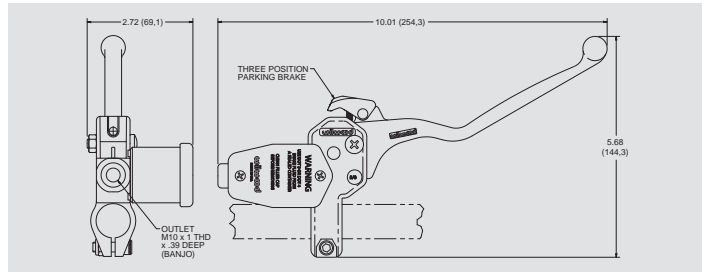

Ordering Information

DESCRIPTION	PART NUMBER
5/8" Bore Handlebar Master Cylinder, Single Outlet, Long Lever, Right Hand	260-11218
5/8" Bore Handlebar Master Cylinder, Single Outlet, Long Lever, Left Hand	260-11219

Kart Master Cylinder (RM1)

Replacement cylinder assembly for Wilwood's kart master cylinder. Easy bolt on replacement onto your existing bracket assembly.

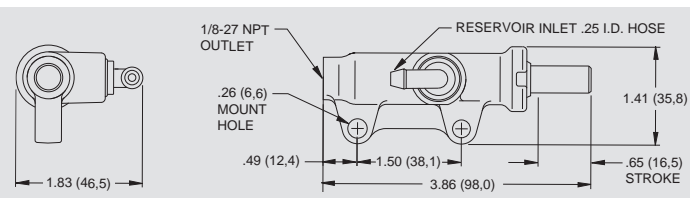

Ordering Information

DESCRIPTION	PART NUMBER
1/2" Bore Kart Master Cylinder, Single Outlet, Bare Aluminum Finish	260-5516

Residual Valve/Slave Cylinder/Check Valve

Wilwood Residual Pressure Valve

These in-line pressure valves retain a minimum brake line pressure to help eliminate excessive pedal travel in both disc and drum brake systems. The two pound valve is used in disc brake applications where the master cylinder is mounted below the horizontal plane of the calipers and fluid drain back occurs from gravity and vibration, thereby causing excessive caliper piston retraction and a longer brake pedal stroke. The minimal two pound residual pressure prevents fluid from flowing back without causing the brakes to drag. With drum brakes, a ten pound valve is used to compensate for return spring tension in the drums. Residual pressure valves are made from billet aluminum and color coded for easy identification. Ideal for Drag Racing, Street Rod and many Off Road applications.

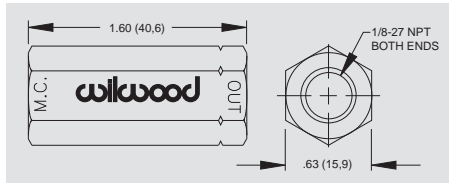

Ordering Information

DESCRIPTION	PART NUMBER	DESCRIPTION	PART NUMBER
2 lb Residual Pressure Valve (blue)	260-1874	10 lb Residual Pressure Valve (red)	260-1876
2 lb Residual Pressure Valve (blue) with Fittings	260-3278	10 lb Residual Pressure Valve (red) w/Fittings	260-3279
1/8-27 Double Ended Brass Fitting - Each	220-2415	1/8-27 to 3/8-24 Tube Adapter - 4 Pack	220-0628

Clutch Slave Cylinder

This "Pull Type" slave cylinder is made from billet aluminum for high strength and plated with a tough anti-corrosion finish. The stainless steel push rod has a longer stroke than most cylinders assuring a full release of the clutch. Ideal for Drag Racing, Late Model Stock, Pro Series and Off Road applications. Recommended master cylinder sizing is 0.75" bore.

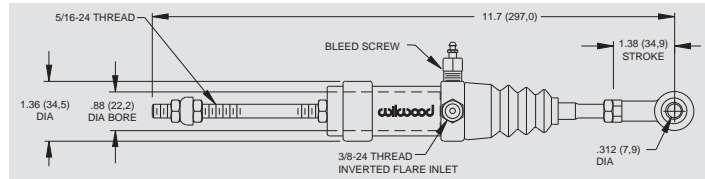

Ordering Information

DESCRIPTION	PART NUMBER
Clutch Slave Cylinder	260-1333
Rebuild Kit, Clutch Slave Cylinder	260-5524

Check Valve

Wilwood compact check valves, or flow control valves are used in conjunction with our caliper self bleed lines. Together they form a closed loop brake fluid system that allows small amounts of brake fluid to circulate every time the brake pedal is depressed, thereby eliminating the possibility of localized fluid boiling and build-up of gases within the brake fluid. Gases end up being vented back into the master cylinder reservoir rather than trapped within the caliper and brake lines. The result is a firmer, more consistent brake pedal under severe braking conditions. Our check valve accepts standard 1/8-27 NPT fittings. For plumbing instructions please download www.wilwood.com/pdf/ds213.pdf.

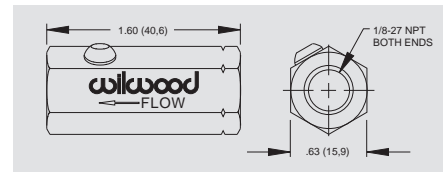

Ordering Information

DESCRIPTION	PART NUMBER
Check Valve (flow control valve)	260-3501
Self Bleed Lines for Superlite 6 and Superlite 4 Caliper (1.25")	190-8310
Self Bleed Lines for Superlite III, SL-GT, LC-GT Calipers (1.25" rotor)	190-4743

Brake Fluid

Wilwood EXP 600 Plus - Extreme Performance Racing Brake Fluid



Wilwood EXP 600 Plus is a highly refined blend developed for extreme performance under the high heat and extreme pressure of professional motorsports. EXP 600 Plus has tested to 626 degrees Fahrenheit with a wet boiling point of 417 degrees Fahrenheit. These numbers far exceed any DOT or SAE specifications.

It is true that racing fluids need to have high boiling points. It is also true that fluids need to have low moisture affinity to slow the natural absorption rate of water vapor. But the true test of any fluid is how well it resists aeration and compressibility after it has been heated and pressure cycled a few hundred times. The real test is at the track. EXP has been proven to maintain firm pedal feel and quick response, long after others have failed.

Ordering Information

DESCRIPTION	PART NUMBER
EXP 600 Plus Six Pack, 6 Each 500 ML Bottles (16.9 fluid ounce)	290-8478
EXP 600 Plus Case, 20 Each 500 ML Bottles (16.9 fluid ounce)	290-6210

Wilwood Hi-Temp°570 Racing Brake Fluid

Wilwood's specially formulated Hi-Temp°570 Racing Brake Fluid has a minimum 570°F. dry boiling point to withstand the severe heat requirements of automotive racing. Hi-Temp°570's low viscosity allows easy bleeding of your brake system, eliminating aeration of the brake fluid, called foaming, due to excessive pumping of the pedal.

Hi-Temp°570 comes in convenient 12 ounce containers hermetically sealed to guarantee against unwanted absorption of moisture which can drastically lower the fluids boiling point (fluid from larger containers tends to become contaminated with moisture, lowering its boiling point and making it unsuitable for racing applications).



Ordering Information

DESCRIPTION	PART NUMBER
Wilwood Hi-Temp°570 Racing Brake Fluid Six Pack, 6 Each 12 Fluid Ounces	290-2210
Wilwood Hi-Temp°570 Racing Brake Fluid Case, 24 Each 12 Fluid Ounces	290-0633

Wilwood DOT 5 "FIVE" Brake Fluid



Wilwood FIVE is a highly refined silicone brake fluid, formulated to preserve the looks and reliability on classic vehicles and show cars. Its non-hygroscopic blend blocks moisture absorption to inhibit internal system corrosion. It is paint friendly and will not harm most custom finishes should a spill or leak occur.

Wilwood FIVE provides superior lubrication for all brake system wear surfaces with long life from the master cylinder and caliper pistons, bores, and seals. It is a fully DOT 5 compliant fluid meeting or exceeding FMVSS 116 and MIL-PRF-46176B-DOT specifications, and can be used in any vehicle that is OEM-specified for DOT 5 use. Wilwood does **NOT RECOMMEND** using DOT 5 fluid in any racing or high performance applications.

Ordering Information

DESCRIPTION	PART NUMBER
Wilwood DOT 5 "FIVE" Silicone Brake Fluid Six Pack, 6 Each 12 Fluid Ounces	290-11085
Wilwood DOT 5 "FIVE" Silicone Brake Fluid Case, 24 Each 12 Fluid Ounces	290-11083

Wilwood Synthetic Assembly Lube

Wilwood's specially formulated synthetic assembly lubricant is designed to be used on pistons and rubber components when overhauling brake calipers, wheel cylinders and master cylinders. Its intended function is to ease assembly. It has much more lubricity than brake fluid.

Comes in a convenient 4 ounce bottle with applicator tip. Also available in a case of 12 - 4 ounce bottles.



Ordering Information

DESCRIPTION	PART NUMBER
Wilwood Synthetic Assembly Lubricant Single, 1 Each 4 Ounce Bottle	290-11087
Wilwood Synthetic Assembly Lubricant Case, 12 Each 4 Ounce Bottle	290-11086

Flexlines & Fittings

Brake Flexlines

Wilwood's stainless steel braided flexlines are manufactured to high quality standards and are available in various -3 and -4 styles. These premium grade flexlines are durable and provide "hard line" pedal feel.

Ordering Information

DESCRIPTION	PART NO.
10.00" Flexline, -3 female to -3 female	220-8763
10.50" Flexline, -3 hose to IF male, 90 degree	220-10711
12.00" Flexline, -3 hose to -3 female	220-8762
12.00" Flexline, -4 hose to -4 female	220-11220
13.00" Flexline, -3 hose with 45 degree block	220-8514
14.00" Flexline, -3 female to -3 female	220-7090
14.00" Flexline, -3 female to -3 female, 90 degree	220-6411
14.00" Flexline, -3 hose to -3 female, 90 degree M10 x 1	220-8928
15.00" Flexline, -3 hose with 30 degree block	220-8515
15.00" Flexline, -3 hose to 3/8-24 convex bulkhead	220-11864
16.00" Flexline, -3 female to -3 female	220-7686
16.00" Flexline, -3 hose to -3 female, 90 degree	220-8523
16.50" Flexline, -3 hose to M10 x 1 female, IF	220-9800
17.00" Flexline, -3 female to 10mm male, DOT	220-8223
17.00" Flexline, -3 hose, w/30 degree banjo, 3/8-24 IF	220-8751
17.00" Flexline, -3 hose, w/30 degree banjo, 7/16-24 IF	220-8752
18.00" Flexline, -3 female to -3 female	220-2156
18.00" Flexline, -3 hose to -3 female, 90 degree	220-10848
18.00" Flexline, -3 hose to -3 female, JIC	220-12324
18.75" Flexline, -3 female w/12 degree banjo, DOT	220-8215
19.00" Flexline, -3 female to 10mm male, DOT	220-8222
20.00" Flexline, -3 female w/12 degree banjo, DOT	220-8216
20.00" Flexline, -3 female to straight 10mm female	220-6861
20.00" Flexline, -3 hose to -3 female	220-8371
20.00" Flexline, -3 hose w/deep ST M10 x 1 IF	220-8840
22.00" Flexline, -3 female to -3 female	220-6414
22.00" Flexline, -3 hose, 10 mm banjo w/ST M10 x 1	220-8929
22.00" Flexline, -3 female to straight 10mm female	220-9684
22.00" Flexline, -3 hose to -3 female	220-11203
23.00" Flexline, 10mm to -3 w/bracket, right hand	220-9331
23.00" Flexline, 10mm to -3 w/bracket, left hand	220-9332
24.00" Flexline, -3 hose to 10mm	220-9364
24.00" Flexline, -4 hose to -4 female	220-9923

Ordering Information

DESCRIPTION	PART NO.
24.00" Flexline, -3 Hose, W.M12 x 1 female, IF	220-10977
24.00" Flexline, M10 x 1 to -3 w/bracket, right hand	220-11591
24.00" Flexline, M10 x 1 to -3 w/bracket, left hand	220-11592
25.00" Flexline, -3 hose to -3 female	220-12762
31.00" Flexline, -4 hose to -4 female	220-9070
31.00" Flexline, -3 Hose, W.M12 x 1 female, IF	220-10977
40.00" Flexline, -3 female to -3 female	220-8317



Brake Line Fittings

Wilwood's brake line fittings are manufactured to high quality standards and are available in various sizes and configurations as outlined below.



Ordering Information

DESCRIPTION	PART NO.	DESCRIPTION	PART NO.
Fitting, 3/8-24 to -3 male (requires P/N 240-2705 washer) Uses: Girling / combination master cylinder outlet	220-3406	Fitting, Inlet, 45 degree elbow, -3 male to 1/8-27 NPT male Uses: Caliper inlet fitting	220-6412
Fitting, 3/8-24 I.D. tube adapter, 3/16 tube female to 3/8-24 (-3 male, long) Uses: Girling / combination master cylinder outlet	220-3407	Frame fitting, tubing 10 mm x 1.00 I.F. to -3 male	220-6413
Fitting, -3 male to 1/8-27 NPT male Uses: Caliper inlet fitting	220-6956	Frame fitting, tubing 10 mm x 1.00 bubble flare to -3 male	220-6890
Tube adapter, 3/16 female tube (3/8-24 I.F.) to 1/8-27 NPT (4 pk) Uses: Proportioning valve, residual valve, master cylinder, caliper inlet (rear)	220-0628	Fitting, Inlet, 90 degree elbow, -3 male to 1/8-27 NPT male Uses: Caliper inlet fitting	220-6415
Frame fitting, 3/16 tube (3/8-24 I.F.) to -3 male	220-6410	Fitting, -6 to 3/8 hose barb, swivel	220-7534
Frame fitting, 7/16 tube (7/16-24 I.F.) to -3 male	220-6457	Fitting, -6 male to 7/16-20 male	220-7537
		Crush washer, -4 (7/16) aluminum Uses: Compact remote master cylinder inlet	240-7538
		Retainer clip, chassis fitting adapter	300-6416

ProSpindle

Wilwood ProSpindle

Designed for increased strength, minimized weight, improved handling, and increased braking capacity on component cars, street rods, drag cars and other custom / competition applications using Ford Mustang II suspension geometry.

One-piece forged steel body is lightweight, yet nearly three times stronger than cast steel original equipment or aftermarket pressed pin replacement spindles.

ProSpindles use common Pinto and Mustang II wheel bearings, seals, ball joints, and tie rod ends.

A 1/2" taller upper spindle body improves the front suspension geometry with a higher front roll center and decreased body roll with no changes to the lower control arm, frame height, or steering linkages.

Wilwood ProSpindles are available in either stock ride height or 2" drop.

Integral mounting bosses forged into the main body of the spindle provide substantially increased anchoring security for lug or radial mount calipers on rotors up to 14.00".

High strength forged steel arms are strong and can be run front or rear steer, or inverted if necessary to improve steering characteristics such as bump steer with relocated or custom mounted steering linkages.

Custom and competition brake kits, built specific for the ProSpindle, are available ranging from 11.00" to 14.00" rotor diameters with choices for four or six piston calipers in all finishes and rotor styles.

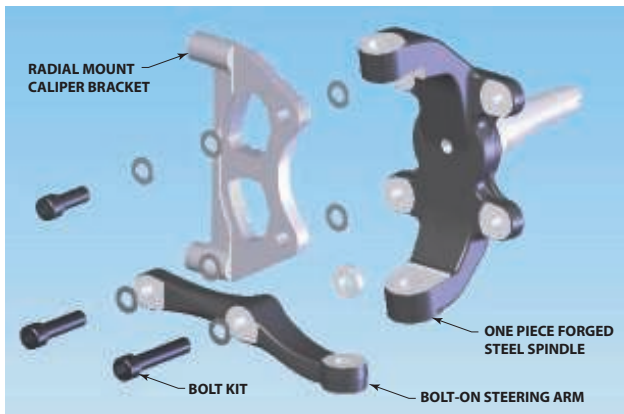

Typical View of Radial Caliper Bracket Installation



Standard Height Shown Left, 2" Drop Shown Right

Ordering Information

DESCRIPTION	PART NUMBER
Wilwood 2" Drop Spindle (includes spindle and steering arm)	830-9807
Wilwood Stock Height Spindle (includes spindle and steering arm)	830-10832

Disc Brake Kits for ProSpindle Ordering Information

KIT PART NO.	CALIPER TYPE	CALIPER COLORS	ROTOR SIZE	ROTOR STYLE
140-9917	Forged Dynalite	Black / Red / Polished	11.00" x .810"	SRP-BLK or HP
140-9918	Forged Dynalite	Black / Red / Polished	12.19" x .810"	SRP-BLK or HP
140-9919	FNSL6R	Black / Red / Polished	12.88" x 1.10"	SRP-BLK or GT
140-9920	FNSL6R	Black / Red / Polished	14.00" x 1.10"	SRP-BLK or
140-10641	W6A	Black / Red	14.00" x 1.10"	SRP-BLK or GT
140-10741	DynaPro 6	Black / Red / Polished	12.19" x .810"	SRP-BLK or HP

Steering Components

Wilwood's "PINTO" Rack and Pinion

Wilwood has available a reproduction of the front steer 1971 - 1972 Pinto rack and pinion. This rack is an all new unit that weighs only 9.5 pounds, and is dimensionally identical to the original Pinto rack. Stock mounting locations and input shaft with the upgrade of over sized rod ends for added strength and reliability make this the popular choice for racing applications. Add a chromed center tube and polished housing as a standard feature, and there is no reason to choose a used or rebuilt unit.

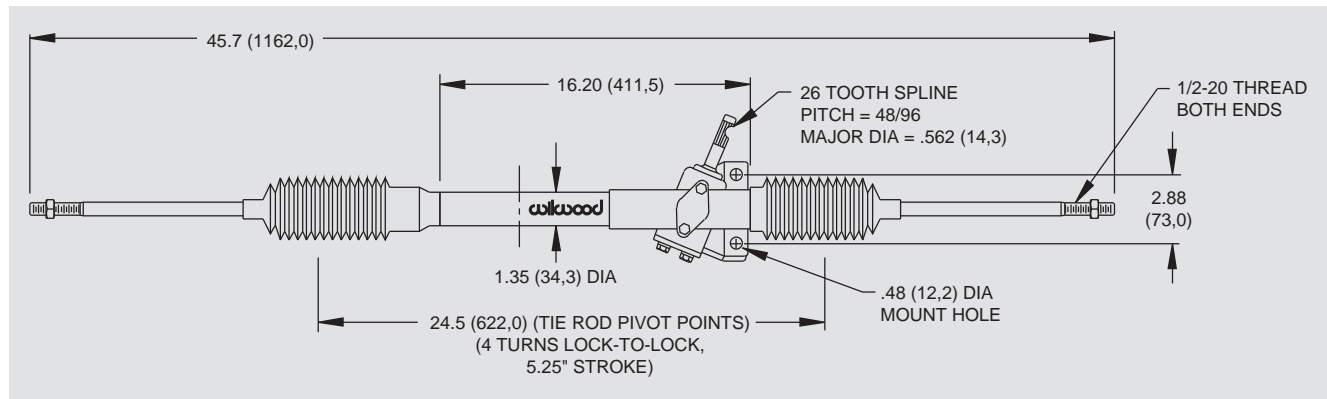

Ordering Information

DESCRIPTION	PART NUMBER
Stock Ratio Rack and Pinion	350-2038
Replacement Boot Kit (pair)	350-8821

Quick Release Steering Hub



Wilwood's lightweight billet aluminum quick release steering hub is a reliable and important safety feature for any race car. The spring loaded button is non-removable and easy to use. The steel steering shaft adapter fits into a precision machined hex bore for a close tolerance fit. It is available to fit either a 5/8" or 3/4" shaft and accepts a standard three bolt steering wheel pattern. Available in a satin black anodized finish.

Ordering Information

DESCRIPTION	PART NUMBER
3/4" Shaft, Black Anodized	270-2016
5/8" Shaft, Black Anodized	270-2017
Replacement 3/4" Steel Shaft	300-2019
Replacement 5/8" Steel Shaft	300-2020

Street Performance Brake Kits

D154 Front Caliper Kit



Kit Components

Caliper:	D154
Pistons:	1 or 2
Mount Type:	Floating
Rotor Diameter:	N/A
Rotor Type:	N/A
Rotor Format:	N/A
Min Wheel Dia:	N/A
Hat:	N/A
Hub:	N/A
Pad Compound:	BP-10 Smart Pad
Finishes:	Black / Red / Polished

This caliper kit is a direct bolt-on 1 or 2 piston, lightweight, high-strength, extreme duty alternative to the OE cast iron "Metric" calipers that were used on a wide range of factory disc brake equipped mid size GM cars and small trucks beginning in 1978. Forged billet aluminum bodies, stainless steel pistons, and competition style high-temperature seals put an end to the rust, bore pitting, and seal failures that plague the OE caliper design. D154 calipers mount in the stock location over stock rotors; use the original style OE D154 brake pads and an OE M10-1.5 banjo bolt brake line mounting. D154 Calipers can be used with most wheels that clear the OE calipers. The front calipers with 2.50" piston provide 4.90 square inches of piston area per caliper, in order to maintain the original front to rear brake bias and use of the OE master cylinder. The D154 is also available in a two piston version with 1.62 pistons, offering 4.12 square inches of area. Kits contain Wilwood's hardened slide pins and BP-10 high friction pads.

D52 Front Caliper Kit

This caliper kit is a direct bolt-on 2 piston replacement for the factory original single calipers on many 1968-96 GM Passenger Vehicles and Trucks. Forged billet aluminum bodies, stainless steel pistons, and competition style high-temperature seals put an end to the rust, bore pitting, and seal failures that plague the OE caliper design. D52 calipers provide low-maintenance performance and a huge weight savings with high temperature reliability for the street and track. D52 calipers mount in the stock location over stock rotors, use the original style OE D52 brake pads and an OE 7/16-20 banjo bolt brake line mounting. Calipers can be used with most wheels that clear the OE calipers. The front calipers with 2.00" piston provide 6.28 square inches of piston area per caliper, in order to maintain the original front to rear brake bias and use of the OE master cylinder. Kits contain Wilwood's hardened slide pins and BP-10 high friction pads. Matching rear calipers are also available for custom installations. Vehicles 1978 & Up (with M10-1.5 banjo bolts) will require new brake lines.

Kit Components

Caliper:	D52
Pistons:	2
Mount Type:	Floating
Rotor Diameter:	N/A
Rotor Type:	N/A
Rotor Format:	N/A
Min Wheel Dia:	N/A
Hat:	N/A
Hub:	N/A
Pad Compound:	BP-10 Smart Pad
Finishes:	Black / Red



D8-4 Front Replacement Caliper Kit



Kit Components

Caliper:	D8-4
Pistons:	4
Mount Type:	Lug
Rotor Diameter:	N/A
Rotor Type:	N/A
Rotor Format:	N/A
Min Wheel Dia:	15.00"
Hat:	N/A
Hub:	N/A
Pad Compound:	BP-10 Smart Pad
Finishes:	Clear/Black/Red/Polished

D8-4 calipers are a direct bolt-on replacement for the OE calipers on all 1965-82 Corvettes. Forged billet aluminum bodies, stainless steel pistons and high-temperature seals put an end to the rust, bore pitting and seal failures that plague the OE caliper design. D8-4 calipers provide low-maintenance performance, a huge weight savings, and high temperature reliability for street or track. D8-4 calipers mount in the stock location over stock rotors, use the original style D8 brake pads, and fit snugly inside most 67 or newer production wheels. Some wheels, including the 1965-66 OE "JK" code steel wheels and a few aftermarket replica alloy wheels, will require a 3/16" or wider wheel spacer for clearance. Kits contain DOT compliant stainless braided brake lines and BP-10 compound "Smart Pads"

D8-6 Front Replacement Caliper Kit

D8-6 calipers are a direct bolt-on replacement for the OE calipers on all 1965-82 Corvettes. Forged billet aluminum bodies, stainless steel pistons and high-temperature seals put an end to the rust, bore pitting and seal failures that plague the OE caliper design. D8-6 calipers provide low-maintenance performance, a huge weight savings, and high temperature reliability for street or track. D8-6 calipers mount in the stock location over stock rotors, use the original style D8 brake pads, and fit snugly inside most 67 or newer production wheels. Some wheels, including the 1965-66 OE "JK" code steel wheels and a few aftermarket replica alloy wheels, will require a 3/16" or wider wheel spacer for clearance. Kits contain DOT compliant stainless braided brake lines and BP-10 compound "Smart Pads"

Kit Components

Caliper:	D8-6
Pistons:	6
Mount Type:	Lug
Rotor Diameter:	N/A
Rotor Type:	N/A
Rotor Format:	N/A
Min Wheel Dia:	15.00"
Hat:	N/A
Hub:	N/A
Pad Compound:	BP-10 Smart Pad
Finishes:	Clear/Black/Red



Street Performance Brake Kits

Forged Dynalite Pro Series Front Brake Kit



Kit Components

Caliper:	Forged Dynalite
Pistons:	4
Mount Type:	Lug
Rotor Diameter:	10.75" - 11.00"
Rotor Type:	Ultralite 30 Vane
Rotor Format:	Undrilled/SRP Drilled & Slotted
Min Wheel Dia:	15.00"
Hat:	N/A
Hub:	Forged Aluminum
Pad Compound:	BP-10 Smart Pad
Finishes:	Black / Red

FDL Pro Series front hub Kits offer complete disc brake upgrade solutions for traditional non-ABS spindle applications on American muscle cars, vintage rods, and heavy weight drag cars. Based on the venerable forged billet Dynalite caliper, these versatile kits are easily optioned to suit the braking requirements and style preferences for a daily driver, serious competition, or the most discriminating show enthusiast. Most kits require no modifications for installation, and provide plenty of clearance inside popular 15" wheels. FDL Pro Series kits can be used with either manual or power boost master cylinders.

Forged Dynalite Big Brake Front Brake Kit (Hub)

FDL big brake front hub kits provide the added advantage of larger diameter brake rotors for traditional non-ABS spindles on American muscle cars and vintage rods. Forged billet Dynalite calipers, 12.19" diameter rotors, and high performance Wilwood brake pads generate big brake stopping power to compliment wheel, tire, and suspension upgrades on all types of custom show and performance street / strip machines. A full range of options for caliper finish and rotor design provide custom builders with the ability to personalize the style and performance requirements of the mildest to the wildest machines.

Kit Components

Caliper:	Forged Dynalite
Pistons:	4
Mount Type:	Lug
Rotor Diameter:	12.19"
Rotor Type:	Ultralite 32 Vane
Rotor Format:	Undrilled/SRP Drilled & Slotted
Min Wheel Dia:	16.00"
Hat:	N/A
Hub:	Forged Aluminum
Pad Compound:	BP-10 Smart Pad
Finishes:	Black / Red



Forged Dynalite Big Brake Front Brake Kit (Hat)



Kit Components

Caliper:	Forged Dynalite
Pistons:	4
Mount Type:	Lug
Rotor Diameter:	11.00" - 12.19"
Rotor Type:	Ultralite 32 Vane
Rotor Format:	Undrilled/SRP Drilled & Slotted
Min Wheel Dia:	16.00"
Hat:	Aluminum
Hub:	N/A
Pad Compound:	BP-10 Smart Pad
Finishes:	Black / Red

Forged billet Dynalite calipers, oversized rotors, and high performance Wilwood brake pads deliver big brake stopping power with high-tech style for front wheel drive sport compacts. These kits are the perfect compliment to wheel, tire, and suspension upgrades. Options for caliper finish and rotor design make it simple to match the brake response and style preferences on all types of daily drivers, race vehicles, and ultra-styled show machines. Each kit is engineered specific for each vehicle. They are fully compatible with OE master cylinder output while retaining the full factory ABS functions.

DynaPro Radial Big Brake Front Brake Kit (Hat)

Radial mounting provides secure and accurate installation of the forged billet DynaPro four piston caliper with large diameter rotors for this group of front and all wheel drive sport compacts. These kits are the perfect compliment to wheel, tire, and suspension upgrades on daily drivers, competition vehicles, and custom styled show machines. Each kit is engineered specific for each vehicle to maintain full compatibility with the OE master cylinder output and factory ABS functions. Optional caliper finishes and rotor designs provide choices that enable the builder to personalize the style and optimize brake performance.

Kit Components

Caliper:	DynaPro Radial Mount
Pistons:	4
Mount Type:	Radial
Rotor Diameter:	11.75" - 12.19"
Rotor Type:	Ultralite 32 Vane
Rotor Format:	GT Slotted/SRP Drilled & Slotted
Min Wheel Dia:	16.00"
Hat:	Aluminum
Hub:	N/A
Pad Compound:	BP-10 Smart Pad
Finishes:	Black / Red



Street Performance Brake Kits

DynaPro 6 Big Brake Front Brake Kit (Hub)



Kit Components

Caliper:	DynaPro 6
Pistons:	6
Mount Type:	Lug
Rotor Diameter:	12.19"
Rotor Type:	Ultralite 32 Vane
Rotor Format:	Undrilled/SRP Drilled & Slotted
Min Wheel Dia:	16.00"
Hat:	N/A
Hub:	Forged Aluminum
Pad Compound:	BP-10 Smart Pad
Finishes:	Black / Red / Polished

DynaPro 6 forged billet calipers are combined with 12.19" diameter rotors for this group of traditional non-ABS spindles on American muscle cars and vintage rods. The enhanced brake capacity and pad performance of the six piston calipers provide an intermediate level alternative to the bigger six piston kits. These kits compliment wheel, tire, and suspension upgrades on all types of custom show and high performance street / strip machines. A full range of caliper finishes and rotor designs enable the builder to personalize the style and optimize the brake performance for each individual application.

DynaPro 6 Big Brake Front Brake Kit (Hat)

The enhanced brake capacity and pad performance of the DynaPro 6 forged billet six-piston caliper is combined with 12.19" diameter rotors for this group of front wheel drive sport compact kits. These kits are the perfect compliment to wheel, tire, and suspension upgrades on daily drivers, competition vehicles, and custom styled show machines. Each kit is engineered vehicle specific to maintain full compatibility with the OE master cylinder output and factory ABS functions. Optional caliper finishes and rotor designs enable the builder to personalize the style and optimize brake performance for every individual application.

Kit Components

Caliper:	DynaPro 6
Pistons:	6
Mount Type:	Lug
Rotor Diameter:	12.19"
Rotor Type:	Ultralite 32 Vane
Rotor Format:	Undrilled/SRP Drilled & Slotted
Min Wheel Dia:	16.00"
Hat:	Aluminum
Hub:	N/A
Pad Compound:	BP-10 Smart Pad
Finishes:	Black / Red



Forged Superlite 4 Big Brake Front Brake Kit (Hub)



Kit Components

Caliper:	Forged Superlite
Pistons:	4
Mount Type:	Lug
Rotor Diameter:	12.19" - 13.00"
Rotor Type:	48 Curved Vane
Rotor Format:	GT Slotted/SRP Drilled & Slotted
Min Wheel Dia:	16.00" - 17.00"
Hat:	Aluminum
Hub:	Forged Aluminum
Pad Compound:	BP-10 Smart Pad
Finishes:	Black / Red

The big pad capacity of the forged Superlite four piston caliper is combined with oversized rotors for this unique group of specialized application kits. The roots of the forged Superlite are deep in competition. It is a track proven performer. But the FSL is far from one dimensional. Lug mounting and a full range of piston sizes give the FSL widespread adaptability for applications with unique mounting and piston volume requirements. Options for caliper finish and rotor design provide the opportunity to configure these kits for high-tech style with full capability for extreme duty use on the street or at the track.

Forged Superlite 4 Big Brake Front Brake Kit (Hat)

The big pad capacity of the forged Superlite four piston caliper is combined with oversized rotors for this unique group of specialized application kits. The roots of the forged Superlite are deep in competition. It is a track proven performer. But the FSL is far from one dimensional. Lug mounting and a full range of piston sizes give the FSL widespread adaptability for applications with unique mounting and piston volume requirements. Options for caliper finish and rotor design provide the opportunity to configure these kits for high-tech style with full capability for extreme duty use on the street or at the track.

Kit Components

Caliper:	Forged Superlite
Pistons:	4
Mount Type:	Lug
Rotor Diameter:	12.88"
Rotor Type:	48 Curved Vane
Rotor Format:	GT Slotted/SRP Drilled & Slotted
Min Wheel Dia:	17.00"
Hat:	Aluminum
Hub:	N/A
Pad Compound:	BP-10 Smart Pad
Finishes:	Black / Red



Street Performance Brake Kits

Forged Narrow Superlite 6R Big Brake Front Brake Kit (Hub)



Kit Components

Caliper:	Forged Narrow Superlite 6R
Pistons:	6
Mount Type:	Radial
Rotor Diameter:	12.88" - 14.00"
Rotor Type:	48 to 72 Curved Vane
Rotor Format:	GT Slotted/SRP Drilled & Slotted
Min Wheel Dia:	17.00" - 18.00"
Hat:	Aluminum
Hub:	Forged Aluminum
Pad Compound:	BP-10 Smart Pad
Finishes:	Black / Red / Polished

SL6R forged billet six-piston calipers with 12.88"-14.00" rotors deliver the ultimate combination of braking power and style in this group of kits engineered for traditional non-ABS spindles on American muscle cars and vintage rods. Built exclusively for 17" and larger wheels, SL6 kits enhance tire and suspension upgrades on all types of custom show and high performance dual-purpose street and track machines. A full range of options for caliper finishes and rotor designs are guaranteed to catch the eye of the most discriminating enthusiast while providing optimized brake performance for every individual application.

Forged Narrow Superlite 6R Big Brake Front Brake Kit (Hat)

The unsurpassed braking capacity of the SL6R forged billet six-piston caliper serves as the base of this group of 12.88"-14.00" big rotor kits for these popular late model vehicles. SL6 kits are engineered application specific for simplified installation and full compatibility with OE master cylinder output and ABS functions where used. Big brake kits provide increased brake capacity and complimentary style with wheel, tire, and suspension upgrades on show cars and high performance street/track machines. Optional caliper finishes and rotor designs simplify personalizing the style and braking requirements of any application.

Kit Components

Caliper:	Forged Narrow Superlite 6R
Pistons:	6
Mount Type:	Radial
Rotor Diameter:	12.88" - 14.00"
Rotor Type:	48 to 72 Curved Vane
Rotor Format:	GT Slotted/SRP Drilled & Slotted
Min Wheel Dia:	17.00" - 18.00"
Hat:	Aluminum
Hub:	N/A
Pad Compound:	BP-10 Smart Pad
Finishes:	Black / Red

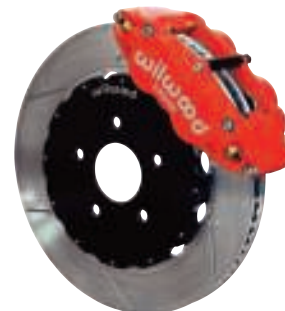

W6AR Big Brake Front Brake Kit



Kit Components

Caliper:	W6AR
Pistons:	6
Mount Type:	Radial
Rotor Diameter:	14.00" - 14.25"
Rotor Type:	72 Curved Vane
Rotor Format:	GT Slotted/SRP Drilled & Slotted
Min Wheel Dia:	18.00" - 19.00"
Hat:	Aluminum
Hub:	N/A
Pad Compound:	BP-20 Smart Pad
Finishes:	Black / Red

W6AR calipers were designed for the specific purpose of providing big capacity braking with large diameter rotors for heavy weight and extreme duty vehicles. It's the biggest of the big providing big brake performance for show and dual purpose street and track vehicles. Kits listed for specific vehicles are fully compatible with OE master cylinder output and ABS function. Direction staggered vane 14.00" - 14.25" rotors provide maximum cooling for sustained high heat durability. Kits come standard with Wilwood's BP-20 Smart Pad friction material.

W6AR Big Brake Front Brake Kit with Carbon Ceramic Rotor

W6AR calipers were designed for the specific purpose of providing big capacity braking with large diameter rotors. It's the biggest of the big providing big brake performance for show and dual purpose street and track vehicles. However, the star of this kit is the Carbon Ceramic 14.00" rotor. Developed to withstand extreme temperatures with the highest possible degree of resistance against distortion, warping, cracking, and wear. Kits listed for specific vehicles are fully compatible with OE master cylinder output and ABS function. Kits come standard with Wilwood's Performance Pad friction material.

Kit Components

Caliper:	W6AR
Pistons:	6
Mount Type:	Radial
Rotor Diameter:	14.00"
Rotor Type:	Straight Vane
Rotor Format:	Carbon Ceramic
Min Wheel Dia:	18.00" - 19.00"
Hat:	Aluminum
Hub:	N/A
Pad Compound:	Performance Pad Compound
Finishes:	Black / Red / Quick-Silver



Street Performance Brake Kits

TC6R Big Brake Truck Front Brake Kit



Kit Components

Caliper:	TC6R
Pistons:	6
Mount Type:	Radial
Rotor Diameter:	16.00"
Rotor Type:	60 Curved Vane
Rotor Format:	GT Slotted/SRP Drilled & Slotted
Min Wheel Dia:	20.00"
Hat:	Aluminum
Hub:	Steel (F-150 Only)
Pad Compound:	BP-10 Smart Pad
Finishes:	Black / Red

TC6R calipers are purpose built to provide unsurpassed braking capacity on trucks and SUV's using 20" and larger wheels and tires. Combining the high clamping efficiency of the TC6R caliper with 16" diameter directional vane rotors and high friction BP-10 compound brake pads, TC6R kits provide the braking power necessary to control the higher rotating weight of ultra-sized wheels and tires, especially with high GVW vehicles and vehicles used for towing. TC6R kits are fully compatible with the OE master cylinder output and retain full function of the ABS system.

ProMatrix Front Replacement Rotor Kit

ProMatrix pad, rotor, and flexline upgrade kits offer measurable brake performance improvements to racers and enthusiasts using the OE factory brake calipers. High performance pad compounds are specially selected to provide increased brake response and higher resistance against fade. Two-piece directional vane GT rotor kits provide high temperature durability for the track. SRP drilled and slotted black E-Coat rotor kits provide high-tech style with corrosion resistance for the street. Stainless steel braided flexlines add style, durability, and firmer response with reduced deflection under load.

Kit Components

Caliper:	N/A
Pistons:	N/A
Mount Type:	N/A
Rotor Diameter:	12.40" - 13.00"
Rotor Type:	48 Curved Vane
Rotor Format:	GT Slotted/SRP Drilled & Slotted
Min Wheel Dia:	17.00"
Hat:	Aluminum
Hub:	N/A
Pad Compound:	PolyMatrix E
Finishes:	N/A



ProMatrix Front and Rear Replacement Rotor Kit



Kit Components

Caliper:	N/A
Pistons:	N/A
Mount Type:	N/A
Rotor Diameter:	11.75" - 12.80"
Rotor Type:	Vented Rotor and Hat
Rotor Format:	Drilled & Slotted
Min Wheel Dia:	N/A
Hat:	Iron Integral
Hub:	N/A
Pad Compound:	N/A
Finishes:	N/A

ProMatrix Front and Rear Rotor Kits offer measurable brake performance improvements to racers and enthusiasts using the OE factory brake calipers and High performance pad compounds. One piece rotors are used to provide high temperature durability for the track or high-tech style with corrosion resistance for the street.

D154 Rear Caliper Kit

D154 rear caliper kit matches our front D154 caliper kit. It is a direct bolt-on 2-piston replacement for the factory original single piston "Metric" calipers used on many custom application rears. With the added benefit of smaller rear piston sizing (1.96 sq-inches of area) not normally available in OEM calipers, for correct front and rear bias. Forged billet aluminum bodies, stainless steel pistons, and competition style high-temperature seals put an end to the rust, bore pitting, and seal failures that plague the OE caliper design. D154 calipers provide low-maintenance performance and a huge weight savings with high temperature reliability for the street and track. D52 calipers mount in the stock location over stock rotors; use the original style OE D154 brake pads and an OE M10-1.5 banjo bolt brake line mounting. Calipers can be used with most wheels that clear the OE calipers. Kits contain Wilwood's hardened slide pins and BP-10 high friction pads.

Kit Components

Caliper:	D154
Pistons:	2
Mount Type:	Floating
Rotor Diameter:	N/A
Rotor Type:	N/A
Rotor Format:	N/A
Min Wheel Dia:	N/A
Hat:	N/A
Hub:	N/A
Pad Compound:	BP-10 Smart Pad
Finishes:	Black / Red / Polished



Street Performance Brake Kits

D52 Rear Caliper Kit



Kit Components

Caliper:	D52
Pistons:	2
Mount Type:	Floating
Rotor Diameter:	N/A
Rotor Type:	N/A
Rotor Format:	N/A
Min Wheel Dia:	N/A
Hat:	N/A
Hub:	N/A
Pad Compound:	BP-10 Smart Pad
Finishes:	Black / Red

D52 Rear Caliper Kit offers a matching rear replacement option for our front D52 calipers. It is a direct bolt-on 2-piston replacement for the factory original single piston calipers used on many custom application rears. With the added benefit of smaller rear piston sizing (2.46 sq-inches of area) not normally available in OE calipers, for correct front and rear bias. Forged billet aluminum bodies, stainless steel pistons, and competition style high-temperature seals put an end to the rust, bore pitting, and seal failures that plague the OE caliper design. D52 calipers provide low-maintenance performance and a huge weight savings with high temperature reliability for the street and track. D52 calipers mount in the stock location over stock rotors, use the original style OE D52 brake pads and an OE 7/16-20 banjo bolt brake line mounting. Calipers can be used with most wheels that clear the OE calipers. Kits contain Wilwood's hardened slide pins and BP-10 high friction pads. Matching rear calipers are also available for custom installations.

D8-4 Rear Replacement Caliper Kit

D8-4 calipers are a direct bolt-on replacement for the OE calipers on all 1965-82 Corvettes. Forged billet aluminum bodies, stainless steel pistons and high-temperature seals put an end to the rust, bore pitting and seal failures that plague the OE caliper design. D8-4 calipers provide low-maintenance performance, a huge weight savings, and high temperature reliability for street or track. D8-4 calipers mount in the stock location over stock rotors, use the original style D8 brake pads, and fit snugly inside most 1967 or newer production wheels. Some wheels, including the 1965-66 OE "JK" code steel wheels and a few aftermarket replica alloy wheels, will require a 3/16" or wider wheel spacer for clearance. Kits contain DOT compliant stainless braided brake lines and BP-10 compound "Smart Pads"

Kit Components

Caliper:	D8-4
Pistons:	4
Mount Type:	Lug
Rotor Diameter:	N/A
Rotor Type:	N/A
Rotor Format:	N/A
Min Wheel Dia:	15.00"
Hat:	N/A
Hub:	N/A
Pad Compound:	BP-10 Smart Pad
Finishes:	Clear/Black/Red/Polished



Forged Dynalite Pro Series Rear Brake Kit



Kit Components

Caliper:	Forged Dynalite
Pistons:	4
Mount Type:	Lug
Rotor Diameter:	12.19"
Rotor Type:	Ultralite 32 Vane
Rotor Format:	Undrilled/SRP Drilled & Slotted
Min Wheel Dia:	15.00"
Hat:	Aluminum
Hub:	N/A
Pad Compound:	BP-10 Smart Pad
Finishes:	Black / Red

FDL Pro Series rear disc brake kits provide a complete solution for popular muscle car rear axles on applications where individual wheel parking brake assemblies are not required. Forged billet Dynalite four piston calipers, two-piece hat and rotor assemblies, and high friction pads provide optimized and balanced braking for all types of off-road, competition, and other customized applications. FDL calipers can be optioned with a full range of finishes to reflect personalized style. Rotor choices provide options for high-tech show winning style, or heavy weight durability and cooling capacity for high heat competition.

Forged DynaPro Low-Profile Rear Parking Brake Kit

DynaPro Low-Profile Pro Series rear disc brake kits provide a complete solution for popular muscle car rear axles on applications that require a parking brake assembly and extra clearance for 14.00" to 15.00" rim applications. Forged billet DynaPro Low-Profile four-piston calipers 11.00" one-piece hat and rotor assemblies, and high friction pads provide optimized and balanced braking for all types of custom performance street/strip and show machines. The neatly hidden internal shoe system provides a clean installation with superior static holding power for parking. Optional caliper finishes and rotor designs enable the builder to personalize the style and optimize brake performance for every individual application.

Kit Components

Caliper:	DynaPro Low-Profile Lug Mount
Pistons:	4
Mount Type:	Lug
Rotor Diameter:	11.00"
Rotor Type:	Ultralite 32 Vane with Hat
Rotor Format:	Undrilled/SRP Drilled & Slotted
Min Wheel Dia:	14.00"
Hat:	Iron Integral
Hub:	N/A
Pad Compound:	BP-10 Smart Pad
Finishes:	Black / Red / Polished



Street Performance Brake Kits

Forged Dynalite Rear Parking Brake Kit



Kit Components

Caliper:	Forged Superlite
Pistons:	4
Mount Type:	Lug
Rotor Diameter:	12.19"
Rotor Type:	Ultralite 32 Vane and Hat
Rotor Format:	Undrilled/SRP Drilled & Slotted
Min Wheel Dia:	15.00"
Hat:	Iron Integral
Hub:	N/A
Pad Compound:	BP-10 Smart Pad
Finishes:	Black / Red

This group of FDL Pro Series rear disc kits provides a complete solution for popular muscle car rear axles that require a parking brake. Forged billet Dynalite four piston calipers, 12.19" one-piece drum/rotors, and high friction pads provide optimized and balanced braking for all types of custom performance street/strip and show machines. The neatly hidden internal shoe system provides a clean installation with superior static holding power for parking. Optional caliper finishes and rotor designs enable the builder to personalize the style and optimize brake performance for every individual application.

Combination Parking Brake Caliper with 1-Piece Rotor Rear Brake Kit

Combination hydro-mechanical parking brake calipers use hydraulic pressure from the master cylinder for stopping power, and an internal mechanical lock within the caliper for a parking brake. CPB kits are built primarily for select rear wheel drive axles that are not well suited for internal shoe style parking brakes. The calipers are coupled with 11 inch one-piece rotor assemblies with integral hats and high friction BP-10 compound pads. CPB kits provide the correct balanced brake performance and matching style to compliment front big brake upgrade kits.

Kit Components

Caliper:	Combination Parking Brake
Pistons:	1
Mount Type:	Radial
Rotor Diameter:	11.00"
Rotor Type:	Ultralite 32 Vane with Hat
Rotor Format:	Undrilled/SRP Drilled & Slotted
Min Wheel Dia:	15.00"
Hat:	Iron Integral
Hub:	N/A
Pad Compound:	BP-10 Smart Pad
Finishes:	Black / Red / Polished



Combination Parking Brake Caliper Rear Brake Kit



Kit Components

Caliper:	Combination Parking Brake
Pistons:	1
Mount Type:	Radial
Rotor Diameter:	11.00" - 12.88"
Rotor Type:	48 Curved Vane
Rotor Format:	Undrilled/SRP Drilled & Slotted
Min Wheel Dia:	17.00"
Hat:	Aluminum
Hub:	N/A
Pad Compound:	BP-10 Smart Pad
Finishes:	Black / Red

Combination hydro-mechanical parking brake calipers use hydraulic pressure from the master cylinder for stopping power, and an internal mechanical lock within the caliper for a parking brake. CPB kits are built primarily for front wheel drive vehicles, and select rear wheel drive axles that are not well suited for internal shoe style parking brakes. The calipers are coupled with oversized two-piece rotor assemblies with aluminum hats and high friction BP-10 brake pads. CPB kits provide the correct balanced brake performance and matching style to compliment front big brake upgrade kits.

DynaPro Rear Brake Kit for Original Equipment Parking Brake

Forged billet DynaPro four piston calipers and high performance BP-10 compound pads generate high clamping power with firm pedal response for this group of specialized rear axle brake kits. These kits retain full function of the OE parking brake and provide complimentary performance and style with front big brake upgrades. Caliper piston sizes are selected to provide balanced rear bias ratios using the output from the OE master cylinder. Rear rotor and hat combinations are engineered specific to each vehicle to provide brake performance upgrades and precise fit with the mounting of the DynaPro calipers.

Kit Components

Caliper:	DynaPro Lug Mount
Pistons:	4
Mount Type:	Lug
Rotor Diameter:	12.19"
Rotor Type:	Ultralite 32 Vane
Rotor Format:	GT Slotted/SRP Drilled & Slotted
Min Wheel Dia:	15.00"
Hat:	Iron
Hub:	N/A
Pad Compound:	BP-10 Smart Pad
Finishes:	Black / Red



Street Performance Brake Kits

DynaPro Radial Rear Brake Kit for Original Equipment Parking Brake



Kit Components

Caliper:	DynaPro Radial Mount
Pistons:	4
Mount Type:	Radial
Rotor Diameter:	12.19" - 12.88"
Rotor Type:	Vented Rotor and Hat
Rotor Format:	GT Slotted/SRP Drilled & Slotted
Min Wheel Dia:	15.00" - 16.00"
Hat:	Iron
Hub:	N/A
Pad Compound:	BP-20 Smart Pad
Finishes:	Black / Red

Forged billet DynaPro four piston calipers and high performance BP-10 compound pads generate high clamping power with firm pedal response for this group of specialized rear axle brake kits. These kits retain full function of the OE parking brake and provide complimentary performance and style with front big brake upgrades. Caliper piston sizes are selected to provide balanced rear bias ratios using the output from the OE master cylinder. Rear rotor and hat combinations are engineered specific to each vehicle to provide brake performance upgrades and precise fit with the mounting of the DynaPro calipers.

Forged Narrow Superlite 4R Big Brake Rear Parking Brake Kit

Forged Narrow Superlite 4R rear disc kits provide the ultimate big brake solution for popular muscle car rear axles that require a parking brake. Billet FNSL4R four piston calipers, 12.88" - 14.00" two-piece rotors, and high performance BP-10 compound pads provide optimized and balanced braking to compliment front big brake upgrades on all types of custom, show and high performance street machines. The neatly hidden internal shoe system provides a clean installation with superior static holding power for parking. Optional caliper finishes and rotor designs allow builders to personalize the style and performance for every application.

Kit Components

Caliper:	Forged Narrow Superlite 4R
Pistons:	4
Mount Type:	Radial
Rotor Diameter:	12.88" - 14.00"
Rotor Type:	48 to 72 Curved Vane
Rotor Format:	GT Slotted/SRP Drilled & Slotted
Min Wheel Dia:	18.00"
Hat:	Iron
Hub:	N/A
Pad Compound:	BP-10 Smart Pad
Finishes:	Black / Red / Polished



Forged Narrow Superlite 4R Big Brake Rear Brake Kit for Original Equipment Parking Brake



Kit Components

Caliper:	Forged Narrow Superlite 4R
Pistons:	4
Mount Type:	Radial
Rotor Diameter:	12.75" - 14.00"
Rotor Type:	48 to 72 Curved Vane
Rotor Format:	GT Slotted/SRP Drilled & Slotted
Min Wheel Dia:	17.00" - 18.00"
Hat:	Iron
Hub:	N/A
Pad Compound:	BP-10 Smart Pad
Finishes:	Black / Red

Forged Narrow Superlite 4R four piston calipers are combined with BP-10 compound pads and 12.75"-14.00" rotors in this group of big brake kits for custom high performance street and show machines. This group of specialized kits for cars, trucks, and SUV's retain full use of the OE parking brake, master cylinder output, and ABS where used. SL4R rear kits provide complimentary style and performance with 13" and larger front brake upgrades in conjunction with wheel, tire, and suspension upgrades. Optional caliper finishes and rotor designs enable the builder to match style and performance on all applications.

W4AR Big Brake Rear Parking Brake Kit

Billet W4AR radial rear disc kits provide the ultimate big brake solution for popular muscle car rear axles that require a parking brake. Billet W4AR four piston calipers, 14.00" two-piece rotors, and high performance BP-10 compound pads provide optimized and balanced braking to compliment front big brake upgrades on all types of custom, show and high performance street machines. The neatly hidden internal shoe system provides a clean installation with superior static holding power for parking. Optional caliper finishes and rotor designs allow builders to personalize the style and performance for every application.

Kit Components

Caliper:	W4A
Pistons:	4
Mount Type:	Radial
Rotor Diameter:	14.00"
Rotor Type:	72 Curved Vane
Rotor Format:	GT Slotted/SRP Drilled & Slotted
Min Wheel Dia:	18.00"
Hat:	Iron
Hub:	N/A
Pad Compound:	BP-10 Smart Pad
Finishes:	Black / Red



Street Performance Brake Kits

W4AR Big Brake Rear Kit for Original Equipment Parking Brake



Kit Components

Caliper: **W4AR**
 Pistons: **4**
 Mount Type: **Radial**
 Rotor Diameter: **14.00" - 14.25"**
 Rotor Type: **72 Curved Vane**
 Rotor Format: **GT Slotted/SRP Drilled & Slotted**
 Min Wheel Dia: **18.00" - 19.00"**
 Hat: **Iron**
 Hub: **N/A**
 Pad Compound: **BP-10 Smart Pad**
 Finishes: **Black / Red**

W4AR big brake rear axle kits replace the factory disc brakes and use the OE parking brake assembly as a compliment to front big brake upgrades on late model high performance vehicles. High capacity braking from the W4AR calipers, BP-10 compound pads, and oversized rotors are matched to the OE master cylinder output, ABS function, and individual vehicle bias requirements. Enhanced brake performance, increased durability, and high-tech style compliment big wheel, tire, and suspension upgrades on customized vehicles and all others with increased brake requirements.

W4AR Big Brake Rear Parking Brake Kit with Carbon Ceramic Rotor

Billet W4AR radial rear disc kits provide the ultimate big brake solution for popular muscle car rear axles that require a parking brake. W4AR four piston calipers, 14.00" two-piece Carbon Ceramic rotors, and high performance pads provide optimized and balanced braking to compliment front big brake upgrades on all types of custom, show and high performance street machines. The neatly hidden internal shoe system provides a clean installation with superior static holding power for parking. Optional caliper finishes allow builders to personalize the style and performance for every application.

Kit Components

Caliper: **W4A**
 Pistons: **4**
 Mount Type: **Radial**
 Rotor Diameter: **14.00"**
 Rotor Type: **Straight Vane**
 Rotor Format: **Carbon Ceramic**
 Min Wheel Dia: **18.00"**
 Hat: **Iron**
 Hub: **N/A**
 Pad Compound: **Performance Compound Pad**
 Finishes: **Black / Red / Quick-Silver**



TC6R Big Brake Truck Rear Brake Kit



Kit Components

Caliper: **TC6R**
 Pistons: **6**
 Mount Type: **Radial**
 Rotor Diameter: **16.00"**
 Rotor Type: **60 Curved Vane**
 Rotor Format: **GT Slotted/SRP Drilled & Slotted**
 Min Wheel Dia: **20.00"**
 Hat: **Iron**
 Hub: **N/A**
 Pad Compound: **BP-10 Smart Pad**
 Finishes: **Black / Red**

TC6R rear axle disc brake kits with 16.00" rotors are the ultimate big brake solution for highly customized and modified trucks or SUV's with 20" and larger wheels. TC6R kits replace the factory disc brakes and use the OE parking brake assembly as a compliment to front big brake upgrades. TC6R calipers, BP-10 compound pads, and oversized rotors are matched to the OE master cylinder output, ABS function, and individual vehicle bias requirements of each vehicle. These combined enhancements provide the necessary control over big wheels and tires to provide safe stopping on heavy weight vehicles.

Narrow Dynalite Rear Inboard Rear Brake Kit

Narrow Dynalite rear inboard kits offer complete disc brake upgrade solutions for Winters IRS Quick Change applications used on Street Rods. Based on the venerable Styled Billet Narrow Dynalite caliper, these versatile kits are easily optioned to suit the braking requirements and style preferences for a daily driver or the most discriminating show enthusiast. Kit require no modifications for installation, and contain 12.19" x .81" rotors, adapters, bolt kits and BP-10 brake pads.

Kit Components

Caliper: **Billet Narrow Dynalite**
 Pistons: **4**
 Mount Type: **Lug**
 Rotor Diameter: **12.19"**
 Rotor Type: **Ultralite 30 Vane**
 Rotor Format: **SRP Drilled & Slotted**
 Min Wheel Dia: **N/A**
 Hat: **Aluminum**
 Hub: **N/A**
 Pad Compound: **BP-10 Smart Pad**
 Finishes: **Polished**



Street Performance Brake Kits

ProMatrix Rear Replacement Rotor Kit



Kit Components

Caliper:	N/A
Pistons:	N/A
Mount Type:	N/A
Rotor Diameter:	11.66" - 12.27"
Rotor Type:	Vented Rotor and Hat
Rotor Format:	GT Slotted/SRP Drilled & Slotted
Min Wheel Dia:	N/A
Hat:	Iron Integral
Hub:	N/A
Pad Compound:	PolyMatrix E
Finishes:	N/A

ProMatrix pad, rotor, and flexline upgrade kits offer measurable brake performance improvements to racers and enthusiasts using the OE factory brake calipers. High performance pad compounds are specially selected to provide increased brake response and higher resistance against fade. Depending on the specific vehicle and parking brake design, one or two-piece rotors are used to provide high temperature durability for the track or high-tech style with corrosion resistance for the street. Stainless steel braided flexlines add style, durability, and firmer response with reduced deflection under load.

Wilwood Disc Brakes

Braking Solutions for a World in Motion

Drag Racing Brake Kits

Dynalite Single Floater Front Drag Brake Kit



Kit Components

Caliper:	Dynalite Single Floater
Pistons:	1
Mount Type:	Floating
Rotor Diameter:	10.00"
Rotor Type:	Solid Steel
Rotor Format:	Undrilled or Drilled
Min Wheel Dia:	N/A
Hat:	Aluminum
Hub:	N/A
Pad Compound:	BP-10 Smart Pad
Finishes:	Black

The Dynalite Single Floater front drag kit is purpose built for use on lightweight cars using spindle mount brakes on P&S / Anglia style spindles. The DLSF calipers and lightweight steel rotors combine to provide excellent static holding power for use as a staging brake or as a supplementary brake on vehicles using parachutes and rear brakes to provide the majority of the stopping power. Aluminum hats are provided to mount the rotors directly to the spindle mount wheels. A choice of solid or lightweight drilled rotors is offered to provide the lowest possible weight to the front axle. Mount brackets are included.

DynaPro Single Front Drag Brake Kit

DynaPro front drag kits incorporate the newest DynaPro caliper technology in this traditional style front brake kit. DPS kits are built for the common front spindles and aftermarket struts used on four-wheel disc brake drag cars that weigh in under 2,400 pounds. The billet DPS caliper is a fixed mount, two-piston design that mounts directly to the spindle with a bolt-on bracket. Forged billet, five lug hubs with direct mount lightweight steel rotors combine to provide consistent braking with an average weight savings of 35 pounds over stock drum or disc brakes. Kits include all new hardware, wheel bearings, seals and 3.00" studs.

Kit Components

Caliper:	DynaPro Single
Pistons:	2
Mount Type:	Lug
Rotor Diameter:	10.00"
Rotor Type:	Solid Steel
Rotor Format:	Undrilled or Drilled
Min Wheel Dia:	14.00"
Hat:	N/A
Hub:	Forged Aluminum
Pad Compound:	BP-10 Smart Pad
Finishes:	Black



Drag Racing Brake Kits

Forged Dynalite Front Drag Brake Kit (Hub)



Kit Components

Caliper:	Forged Dynalite
Pistons:	4
Mount Type:	Lug
Rotor Diameter:	10.75"
Rotor Type:	Solid Steel
Rotor Format:	Undrilled or Drilled
Min Wheel Dia:	15.00"
Hat:	N/A
Hub:	Forged Aluminum
Pad Compound:	BP-10 Smart Pad
Finishes:	Black

Forged Dynalite front drag kits are drag racing's most popular front brake kits. FDL kits are available for the popular muscle car spindles and select aftermarket front struts used on four wheel disc cars weighing up to 2,800 pounds, or rear drum brake equipped cars weighing up to 2,400 pounds. Forged billet FDL four piston calipers mount directly to the spindle with a bolt-on bracket. Forged billet, five lug hubs with direct mount steel rotors combine to provide an average weight savings of over 30 pounds compared to stock drum or disc brakes. Kits include all new hardware, wheel bearings, seals and 3.00" lug studs.

Forged Dynalite Front Drag Brake Kit (Hat)

Forged Dynalite front drag brake kits with hats are drag racing's most popular front brake kits. FDL kits are available for the popular Import car spindles or front struts used on four wheel disc cars weighing up to 2,800 pounds, or rear drum brake equipped cars weighing up to 2,400 pounds. Forged billet FDL four piston calipers mount directly to the spindle with a bolt-on bracket. Forged Hats with direct mount steel rotors combine to provide an average weight savings of over 30 pounds compared to stock drum or disc brakes. Kits include attachment hardware, brake pads, and instructions.

Kit Components

Caliper:	Forged Dynalite
Pistons:	4
Mount Type:	Lug
Rotor Diameter:	11.75"
Rotor Type:	Solid Steel
Rotor Format:	Undrilled or Drilled
Min Wheel Dia:	15.00"
Hat:	Aluminum
Hub:	N/A
Pad Compound:	BP-10 Smart Pad
Finishes:	Black



DynaPro Radial Front Drag Brake Kit



Kit Components

Caliper:	DynaPro Radial Mount
Pistons:	4
Mount Type:	Radial
Rotor Diameter:	11.75"
Rotor Type:	Solid Steel
Rotor Format:	Undrilled or Drilled
Min Wheel Dia:	15.00"
Hat:	Aluminum
Hub:	N/A
Pad Compound:	BP-10 Smart Pad
Finishes:	Black

DynaPro radial forged billet, radial mount four piston calipers are used in this select group of drag racing kits. The OE brakes on vehicles originally equipped with 16" or larger wheels generally do not fit inside the popular 15" drag wheels. Specially designed radial caliper mount brackets bolt directly to the OE caliper mount, and provide secure and accurate mounting for the DPR caliper. Kits with 3/8" steel rotors are recommended for four-wheel disc brake cars up to 2,800 pounds. Kits with .81" rotors should be used on cars over 2,800 pound cars, or lighter cars running extreme speeds desiring increased rotor durability.

Forged Dynalite Rear Drag Brake Kit

Forged Dynalite rear drag kits are true bolt-on kits available for all popular muscle car rear axles and aftermarket rears built with custom axle ends. Kits in this group are purpose built for sportsman category door cars and others with full functional four-wheel disc brakes. Based on the specific style of housing end and axle offset, mounting kits securely install the four-piston forged Dynalite caliper over 3/8" plate steel rotors that are mounted to the axle with an aluminum hat. Standard kits include solid face rotors, with optional drilled rotor kits available to further reduce driveline weight in classes where every weight advantage is necessary.

Kit Components

Caliper:	Forged Dynalite
Pistons:	4
Mount Type:	Lug
Rotor Diameter:	11.44"
Rotor Type:	Solid Steel
Rotor Format:	Undrilled or Drilled
Min Wheel Dia:	15.00"
Hat:	Aluminum
Hub:	N/A
Pad Compound:	BP-10 Smart Pad
Finishes:	Black



Drag Racing Brake Kits

Forged Dynalite Dynamic Mount Rear Drag Brake Kit



Kit Components

Caliper:	Forged Dynalite
Pistons:	4
Mount Type:	Lug
Rotor Diameter:	11.44"
Rotor Type:	Solid Steel
Rotor Format:	Undrilled or Drilled
Min Wheel Dia:	15.00"
Hat:	Aluminum
Hub:	N/A
Pad Compound:	PolyMatrix E
Finishes:	Black

Dynamic rotor mounting is especially beneficial to cars that rely heavily on the rear brakes for stopping, and any other high speed, heavy weight cars that generate above average rear brake heat. Dynamic mounting uses floating t-nuts to isolate the different thermal expansion rates between the steel rotor plate and the aluminum rotor hat. This reduces any tendency for the rotor to distort and impose any additional stress on the hat. Performance, durability, and the service life of the components are all extended. Additionally, distortion free parts run with lower rolling resistance to produce higher speeds.

Forged Dynalite Dual Dynamic Mount Rear Drag Brake Kit

Dual caliper kits provide the highest degree of safety, reliability, and unsurpassed stopping power for sportsman category dragsters and other cars that rely on rear brakes only for stopping power. With two calipers at each wheel, the fluid circuits for each caliper pair can be fully isolated with dual mount or tandem outlet master cylinders. Isolating the fluid circuits prevents complete system failures in the case of a problem with any single caliper or line. Dynamic rotor mounting eliminates distortion caused by the different thermal expansion rates between the steel rotor plate and the aluminum hat.

Kit Components

Caliper:	Forged Dynalite
Pistons:	4
Mount Type:	Lug
Rotor Diameter:	11.44"
Rotor Type:	Solid Steel
Rotor Format:	Undrilled or Drilled
Min Wheel Dia:	15.00"
Hat:	Aluminum
Hub:	N/A
Pad Compound:	PolyMatrix E
Finishes:	Black



DynaPro Lug Drive Dynamic Rear Drag Brake Kit



Kit Components

Caliper:	Billet DynaPro
Pistons:	4
Mount Type:	Lug
Rotor Diameter:	11.44"
Rotor Type:	Solid Steel
Rotor Format:	Drilled
Min Wheel Dia:	15.00"
Hat:	Aluminum
Hub:	N/A
Pad Compound:	CM - Composite Metallic
Finishes:	Black

Wilwood's Billet DynaPro Lug-Drive Dynamic Stainless Alloy Rotor Brake Kits are especially beneficial to cars that rely heavily on the rear brakes for stopping. The lug-drive rotor mounting system eliminates the rotor bolts and instead, a large single internal snap-ring retains the rotor in the hat. This system allows the rotors to move independently of the hats as they expand and contract through heat cycles. All thermally generated stress is removed from the rotor attachment points. The rotors stay flatter and run truer. The hats are no longer distorted by stresses generated by thermal expansion and shrinkage of the rotors. Spring-loaded, replaceable stainless steel inserts in each lug-drive slot protect the aluminum hat from wear. Kits are available in Single and Dual caliper configurations.

Technical Tip

Locating a Wilwood Dealer

Wilwood has a vast dealer network to assist you in obtaining the kits, or associated components necessary for your project. To find a local dealer, go to our web site at www.wilwood.com. Go to the "About Wilwood" drop down menu and select "Find a Dealer". Enter your information in the applicable fields and press the submit button.

Road Race Brake Kits

Billet Superlite 4R Big Brake Front Brake Kit (Race)



Kit Components

Caliper: **Billet Superlite 4R**
 Pistons: **4**
 Mount Type: **Radial**
 Rotor Diameter: **12.19"**
 Rotor Type: **48 Curved Vane**
 Rotor Format: **GT Slotted**
 Min Wheel Dia: **16.00"**
 Hat: **Aluminum**
 Hub: **N/A**
 Pad Compound: **PolyMatrix H**
 Finishes: **Black**

Kits in this competition group are configured for use in production category road racing that allow brake upgrades, but limit modifications to four-piston calipers and 12.20" rotors. BSL4R/ST calipers use Thermlock® pistons to resist fade and extend service life by reducing the heat transfer into the caliper from the pads. GT series directional vane rotors provide high cooling efficiency and durability mounted to the hubs with forged aluminum GT hats. Kits also include high temperature race compound pads, stainless steel flexlines, and premium grade hardware for installation in 16.00" and larger wheels.

Billet Superlite 6R Big Brake Front Brake Kit (Race)

Kits in this competition group are configured for use in unrestricted class road racing with 17.00" or larger wheels. BSL6R/ST six-piston calipers with Thermlock® pistons are matched with 12.88" directional vane GT competition rotors. These proven winners have delivered championship performance in road racing's most grueling production car categories. Rotors mount to the hubs with forged aluminum hats and radial mount brackets secure the calipers to the OE location without modification. Kits also include high friction race compound pads, premium grade hardware, and stainless steel braided flexlines.

Kit Components

Caliper: **Billet Superlite 6R**
 Pistons: **6**
 Mount Type: **Radial**
 Rotor Diameter: **12.88"**
 Rotor Type: **48 Curved Vane**
 Rotor Format: **GT Slotted**
 Min Wheel Dia: **17.00" - 18.00"**
 Hat: **Aluminum**
 Hub: **N/A**
 Pad Compound: **PolyMatrix H**
 Finishes: **Black**



W4AR Big Brake Front Brake Kit (Race)



Kit Components

Caliper: **W4AR/ST**
 Pistons: **4**
 Mount Type: **Radial**
 Rotor Diameter: **14.00"**
 Rotor Type: **72 Curved Vane**
 Rotor Format: **GT Slotted**
 Min Wheel Dia: **18.00"**
 Hat: **Aluminum**
 Hub: **N/A**
 Pad Compound: **PolyMatrix H**
 Finishes: **Black**

W4AR/ST four piston radial mount calipers are coupled with the high cooling capacity of 14.00" SV-GT staggered directional vane rotors to provide the ultimate brake package for unrestricted road race competition. Thermlock® pistons in the calipers resist fade and extend service life by reducing the heat transfer from the pads, caliper body, fluid, and seals. Rotors mount to the hubs with forged aluminum hats and radial mount brackets secure the caliper to the spindle in the OE location without modification. Kits also include high temperature, high friction race compound pads and all premium grade fasteners.

W6AR Big Brake Front Brake Kit (Race)

W6AR/ST six piston radial mount calipers are coupled with the high cooling capacity of 14.25" SV-GT staggered directional vane rotors to provide the ultimate brake package for unrestricted road race competition. Thermlock® pistons in the calipers resist fade and extend service life by reducing the heat transfer from the pads, caliper body, fluid, and seals. Rotors mount to the hubs with forged aluminum hats and radial mount brackets secure the caliper to the spindle in the OE location without modification. Kits also include high temperature, high friction race compound pads and all premium grade fasteners.

Kit Components

Caliper: **W6AR/ST**
 Pistons: **6**
 Mount Type: **Radial**
 Rotor Diameter: **14.25"**
 Rotor Type: **72 Curved Vane**
 Rotor Format: **GT Slotted**
 Min Wheel Dia: **18.00" - 19.00"**
 Hat: **Aluminum**
 Hub: **N/A**
 Pad Compound: **PolyMatrix H**
 Finishes: **Black**



Road Race/Open Wheel Brake Kits

Superlite 4R Big Brake Rear Brake Kit (Race)



Kit Components

Caliper:	Billet Narrow Superlite 4R
Pistons:	4
Mount Type:	Radial
Rotor Diameter:	12.88"
Rotor Type:	48 Curved Vane
Rotor Format:	GT Slotted
Min Wheel Dia:	17.00"
Hat:	Aluminum
Hub:	N/A
Pad Compound:	PolyMatrix H
Finishes:	Black

Billet Superlite 4R caliper rear road race kits provide matched performance in conjunction with SL6R and W6A front race kits on vehicles built specifically for competition. BSL4R calipers use stainless steel pistons to retard heat transfer from the pads and high temperature seals for reliability in sustained high heat. Radial mount brackets attach the caliper in the stock location. GT series directional vane competition rotors provide high efficiency cooling and mount to the drive axles with forged aluminum hats. Kits also include high temperature, high friction race compound pads and all premium grade fasteners.

GP 320 Sprint Front Brake Kit

The GP 320 System features Wilwood's competition proven dynamic rotor mount system, specially treated lightweight Super Alloy rotors, and the highly efficient clamping force of the GP 320 billet aluminum 4 piston caliper for the most positive and fade-free performance available.

Component features: GP 320 billet aluminum 4 piston calipers, Super Alloy rotors, dynamic mounting with Wilwood's t-nut system, dynamic mount rotor plate, Wilwood 6211-CM brake pads, A rigid caliper mounting bracket with premium grade fasteners and shim washers are included for secure, deflection free mounting.

Kit Components

Caliper:	GP 320
Pistons:	4
Mount Type:	Lug
Rotor Diameter:	10.50"
Rotor Type:	Super Alloy
Rotor Format:	Drilled or Slotted
Min Wheel Dia:	N/A
Hat:	N/A
Hub:	Aluminum Dynamic
Pad Compound:	CM - Composite Metallic
Finishes:	Black



GP 320 Sprint Left Front Brake Kit



Kit Components

Caliper:	GP320
Pistons:	4
Mount Type:	Lug
Rotor Diameter:	10.50"
Rotor Type:	Super Alloy
Rotor Format:	Drilled
Min Wheel Dia:	N/A
Hat:	N/A
Hub:	Aluminum Dynamic
Pad Compound:	CM - Composite Metallic
Finishes:	Black

Wilwood's GP 320 Sprint left front brake kit offers increased braking torque and thermal performance of the GP 320 4 piston calipers. A definitive increase in braking and durability over traditional aluminum or steel rotor systems. Mounts are included for standard Sprint spindle to match the included 10.50" x .19" Super Alloy rotor. Also includes composite metallic brake pads, lightweight aluminum dynamic mount 3-pin rotor adapter and t-nut hardware kit.

GP 320 Sprint Right Rear Brake Kit

Wilwood's GP 320 Sprint right rear brake kit offers increased braking torque and thermal performance of the GP 320 4 piston calipers. A definitive increase in braking and durability over traditional aluminum rotor systems. Kit includes 10.50" x .19" Super Alloy rotor, composite metallic brake pads, lightweight aluminum dynamic mount splined rotor adapter and t-nut hardware kit.

Kit Components

Caliper:	GP320
Pistons:	4
Mount Type:	Lug
Rotor Diameter:	10.50"
Rotor Type:	Super Alloy
Rotor Format:	Drilled
Min Wheel Dia:	N/A
Hat:	N/A
Hub:	Aluminum Dynamic
Pad Compound:	CM - Composite Metallic
Finishes:	Black



Open Wheel/Motorcycle Brake Kits

DynaPro Lug Mount Midget Inboard Kit



Kit Components

Caliper: **DynaPro Lug Mount**
 Pistons: **4**
 Mount Type: **Lug**
 Rotor Diameter: **10.50"**
 Rotor Type: **Super Alloy**
 Rotor Format: **Drilled or Slotted**
 Min Wheel Dia: **N/A**
 Hat: **N/A**
 Hub: **Aluminum Dynamic**
 Pad Compound: **CM - Composite Metallic**
 Finishes: **Black**

A fully engineered bolt-on brake system for midget quick change rears with 2.50" x 38 splined axles. With Super Alloy, 78" vented discs and a newly designed dynamic mount rotor axle clamp, are the lowest rotating weights available for Midget racing. The lightweight advantages of the Super Alloy rotor are fortified with the high durability, long wear, and superior heat control properties of advanced technology. Forged billet DynaPro lug mount calipers with composite metallic pads, produce superior stopping power and consistent fade-free response. Kit includes axle clamp with dynamic mount rotor adapter assembly with t-nuts and mounting hardware.

DynaPro Radial Sprint Inboard Brake Kit

Dynapro Radial Sprint Inboard Kit Features a fully engineered bolt-on brake system for sprint car quick change rears with 3.00 x 46 splined axles. With titanium .810 vented discs and a newly designed dynamic mount rotor axle clamp, yield the lowest rotating weights available for Sprint racing. The lightweight advantages of the titanium rotor are fortified with the high durability, long wear, and superior heat control properties. Forged billet DynaPro radial mount calipers with composite metallic pads, produce superior stopping power and consistent fade-free response.

Kit Components

Caliper: **Narrow DynaPro Lug Mount**
 Pistons: **4**
 Mount Type: **Radial**
 Rotor Diameter: **10.50"**
 Rotor Type: **Scalloped 24 Vane**
 Rotor Format: **Drilled**
 Min Wheel Dia: **N/A**
 Hat: **N/A**
 Hub: **Aluminum Dynamic**
 Pad Compound: **CM - Composite Metallic**
 Finishes: **Black**



Dynalite Radial Sprint Inboard Brake Kit



Kit Components

Caliper: **Narrow Mount Dynalite Radial**
 Pistons: **4**
 Mount Type: **Radial**
 Rotor Diameter: **12.00"**
 Rotor Type: **titanium**
 Rotor Format: **Slotted**
 Min Wheel Dia: **N/A**
 Hat: **N/A**
 Hub: **Aluminum Dynamic**
 Pad Compound: **CM - Composite Metallic**
 Finishes: **Black**

This complete brake kit features the 3.3 pound Ben Cook Titanium 12.00" x .36" rotor to offer maximum brake torque in an extremely lightweight package. The kit also includes Wilwood Engineering's Billet Narrow Mount Dynalite Radial (BNDLR) mount caliper with 1.75" pistons, 3.50" radial mount bracket and specially formulated composite metallic pads designed for use with Titanium rotors. A new and improved axle clamp and adaptor plate provide ease of installation, along with our re-engineered dynamic mount system which incorporates fully forged steel t-nuts for trouble free, reliable performance.

GP 310 Motorcycle Rear Brake Kit

Wilwood's GP 310 rear kit for Harley Davidson® 2000-06 FLH / FLT contains GP 310 calipers available in chrome or polished finish, BP-10 high-friction brake pads, bracket (in a chrome or polished finish) and bracket mounting hardware. Mounts over OE diameter stock or aftermarket 11.50" diameter rotors.

Front calipers and components are available on page 21.

Kit Components

Caliper: **GP 310**
 Pistons: **4**
 Mount Type: **Lug**
 Rotor Diameter: **11.50"**
 Rotor Type: **N/A**
 Rotor Format: **N/A**
 Min Wheel Dia: **N/A**
 Hat: **N/A**
 Hub: **N/A**
 Pad Compound: **BP-10 Smart Pad**
 Finishes: **Chrome / Polished**



Motorcycle/OEM Brake Kits

GP 310 Motorcycle Rear Sprocket Brake Kit



Kit Components

Caliper:	GP 310
Pistons:	4
Mount Type:	Lug
Rotor Diameter:	9.94"
Rotor Type:	Motorcycle (sprocket)
Rotor Format:	Drilled
Min Wheel Dia:	N/A
Hat:	N/A
Hub:	N/A
Pad Compound:	BP-10 Smart Pad
Finishes:	Chrome / Polished

Wilwood's sprocket brake system is available in either 48 or 51 tooth sprockets. The bolt circle is consistent on all Harley Davidson® models, 5 x 3.25". The accompanying GP 310 calipers are available in either chrome or a bright polished finish. Sprocket brake calipers are currently available for left hand applications only.

Front caliper and components are available on page 21.

GNX4 Front Brake Kit

GNX4 caliper Brake Kits are the product of Wilwood's in-house FEA design and 3-D modeling technology. Paired with 12.00" diameter, .95" width rotors offers a durable, high torque braking solution for AM General Military HUMVEE vehicles. The GNX4 Caliper with its unyielding strength and superior piston design, generates positive pedal response and high clamping efficiency with a substantial weight savings over original Calipers. The caliper features a natural aluminum finish protected by a durable clear coat anodizing. Forged billet aluminum bodies, stainless steel pistons, and high-temperature seals put an end to the rust, bore pitting, and seal failures that plague many OE caliper designs. Stainless steel pistons delay the heat transfer from the pads while the aluminum calipers dissipate the heat quicker than the OE cast iron calipers. Cooler operating temperatures translate into longer service life, regardless of the driving environment.

Kit Components

Caliper:	GNX4
Pistons:	4
Mount Type:	Lug
Rotor Diameter:	12.00"
Rotor Type:	53 Vane
Rotor Format:	Undrilled
Min Wheel Dia:	N/A
Hat:	Iron Integral
Hub:	N/A
Pad Compound:	CM - Composite Metallic
Finishes:	Clear



GNX4 Rear Brake Kit



Kit Components

Caliper:	GNX4
Pistons:	4
Mount Type:	Lug
Rotor Diameter:	12.00"
Rotor Type:	53 Vane
Rotor Format:	Undrilled
Min Wheel Dia:	N/A
Hat:	Iron Integral
Hub:	N/A
Pad Compound:	CM - Composite Metallic
Finishes:	Clear

GNX4 caliper Brake Kits are the product of Wilwood's in-house FEA design and 3-D modeling technology. Paired with 12.00" diameter, .95" width rotors offers a durable, high torque braking solution for AM General Military HUMVEE vehicles. The GNX4 Caliper with its unyielding strength and superior piston design, generates positive pedal response and high clamping efficiency with a substantial weight savings over original Calipers. The caliper features a natural aluminum finish protected by a durable clear coat anodizing. Forged billet aluminum bodies, stainless steel pistons, and high-temperature seals put an end to the rust, bore pitting, and seal failures that plague many OE caliper designs. Stainless steel pistons delay the heat transfer from the pads while the aluminum calipers dissipate the heat quicker than the OE cast iron calipers. Cooler operating temperatures translate into longer service life, regardless of the driving environment.

Trouble Shooting

Trouble Shooting

This table lists some of the most common items than can signal problems with your brake system. Please consult this table before calling Wilwood. However, if your problem is not found here, please check our Frequently Asked Questions section on our web site at www.wilwood.com - support drop down menu/tech support/FAQs. If the solution given does not solve the problem, please do not hesitate to contact Wilwood technical support at (805) 388-1188 for assistance.

<u>SYMPTOM</u>	<u>CAUSE</u>	<u>SOLUTION</u>
LOSE YOUR PEDAL DURING RACE	Fluid boiling due to wet fluid or foot drag.	Flush out entire system with fresh Wilwood Hi-Temp° 570 racing brake fluid. Install dashboard brake light reminder.
	Undersize brake system.	Refer to the caliper portion of the catalog to select the correct caliper/rotor combination for your application.
	Wrong size residual pressure valve.	Use no larger than 2 lb residual pressure valve.
	Incorrect or faulty master cylinder.	Repair or replace master cylinder.
	Leak in caliper or hydraulic lines.	Check for leaks in caliper and (replace) lines.
	Inadequate ducting.	Reposition air ducts to center of rotor and caliper. (refer to Wilwood air duct technical sheet)
	Pedal linkage failure.	Check pedal assembly.
	Excessive spindle deflection in corners.	Check spindles for warpage. Install 2 lb residual pressure valve.
BRAKE DRAG	Bad master cylinder.	Switch or replace master cylinder.
	Incorrect residual pressure valve.	Use no larger than 2 lb residual pressure valve.
	Rotors warped.	Replace rotors.
	Calipers not square to rotor.	Re-align brackets or shim calipers.
	Tapered brake pads.	Replace pads, check caliper alignment to rotor.
	M/C has internal residual pressure.	Remove residual pressure valve.
CAR WILL NOT STOP	Glazed pads and/or rotors.	Grind and/or sand glaze from rotors, and replace pads
HAVE TO PUSH HARD ON PEDAL	Too large of a master cylinder.	See master cylinder section of catalog to select the correct size unit for your application.
	Not enough pedal ratio.	Increase pedal ratio, see pedal section of catalog.

Trouble Shooting

Trouble Shooting

<u>SYMPTOM</u>	<u>CAUSE</u>	<u>SOLUTION</u>
HAVE TO PUSH HARD ON PEDAL	Pedal mounted at bad angle.	Master cylinder push rod should not be off more than 5° in any angle
	Wrong pad material for your applications.	Pads must match rotor operating temperature range. See pad section of catalog.
	Frozen pistons in calipers.	Rebuild calipers.
CALIPER LEAKS	Caliper seal old or dried out.	Replace with new seals.
	Nick or ding on piston or cut seal.	Replace pistons and/or seals as necessary.
SPONGY PEDAL OR BOTTOMS OUT	Air in brake system.	Re-bleed the system.
	Calipers not bled with bleed screws straight up.	Unbolt calipers and hold with bleed screws in the vertical position.
	Wrong size master cylinder (too small).	Refer to master cylinder section of catalog to select the correct size for your application.
	Faulty master cylinder.	Replace master cylinder.
	Calipers not mounted square to the rotor.	Re-align brackets parallel to rotor or shim caliper.
	Calipers mounted equal to, or higher than master cylinder.	Install 2 pound in-line residual pressure valve.
	Calipers flex excessively.	Check pressure. Do not exceed 1,500 P.S.I.
	Pedal ratio too great.	Reduce pedal ratio.
	Excessive spindle deflection in corners causing piston knock-back.	Install 2 pound in-line residual pressure valve. Check spindles for warpage.
OSCILLATION FEED BACK IN PEDAL	Pad material buildup on rotors.	Change pads, clean rotor face.
	Calipers loose.	Tighten caliper mounting bolts.
	Rotor faces not parallel.	Re-grind rotor faces or replace rotors.
	Cracked rotors.	Replace rotors.
	Excessive front bearing clearance.	Check for proper bearing size or tighten the spindle nut.

Technical Tips

Brake Fluid Tech Tip

Due to the extreme operating temperatures of a high performance brake system, standard “parts store” brake fluids are not recommended. Of critical importance in determining a fluid’s ability to handle high temperature applications are its dry boiling point and compressibility.

The dry boiling point is the temperature at which a brake fluid will boil in its virgin non-contaminated state. The minimum temperature dry boiling point available in a DOT 3 fluid is 401°F, while in a DOT 4 fluid it is 446° F.

The wet boiling point is the temperature a brake fluid will boil after it has been fully saturated with moisture. The DOT 3 requirement for wet boiling point is a minimum temperature of 284°F, while DOT 4 is 311°F.

There are many ways for moisture to enter your brake system. Condensation from regular use, washing the vehicle and humidity are the most common, with little hope of prevention. Glycol based DOT 3 & 4 fluids are hygroscopic; they absorb brake system moisture, and over time the boiling point is gradually reduced.

Wilwood does not recommend using DOT 5 silicone fluid in any racing applications. DOT 5 silicone fluid is not hygroscopic, so as moisture enters the system, it is not absorbed by the fluid and results in beads of moisture moving through the brake line, collecting in the calipers. It is not uncommon to have caliper temperatures exceed 200° F, and at 212° F, this collected moisture will boil causing vapor lock and system failure. Additionally, DOT 5 silicone fluid is highly compressible due to aeration and foaming under normal braking conditions, providing a spongy brake feel. DOT 5 silicone fluid is best suited for show car applications where its anti-corrosion and paint friendly characteristics are important. Try Wilwood’s FIVE DOT 5 Silicone Brake Fluid for these applications.

Whenever you add fresh fluid to your existing system, it immediately becomes contaminated, lowering the boiling point of the new fluid. For maximum performance, start with the highest dry boiling point available. Flush the system completely and flush it regularly, especially after severe temperatures have been experienced. If necessary, to insure degraded fluid and contamination have been completely removed from the system, disassemble, clean and rebuild brake system components. Try Wilwood’s DOT 4 EXP 600 Plus Racing Brake Fluid or DOT 3 Hi-Temp° 570 Racing Brake Fluid.

Brake System Cooling Tech Tip

Proper air ducting is critical for effective performance of short track stock car disc brake systems. Faster cars, improved tires and better aerodynamics has changed the design requirements for brake ducting. Short tracks and most road courses require specific air duct considerations to maximize the brake systems effectiveness.

Channeling sufficient air from the front of the car through the front brakes is required to remove the large amounts of heat generated by severe and prolonged brake use. An efficient air ducting system can prevent brake system overheating and greatly improve pad life. As car designs have evolved, the aerodynamics of the car’s front end has changed, thereby affecting the air flow entering the front air scoops (plenum). Because of this change in air flow, the positioning of intake plenums should be re-evaluated.

By repositioning the plenum intakes vertically as close as possible to the center of the vehicle, air flow is increased. Vertically placed intakes reduce the unwanted effect of air skimming past the duct openings. Locating the intake ducts closer to the center of the vehicle positions them in a high pressure area resulting in greater intake air flow. For more information on brake cooling, order Wilwood’s AIR DUCTING for Short Track Stock Car Racing, DS-254.

Caliper Bleed Screws Pointing Up Tech Tip

When bleeding the brakes, make sure the bleed screws on the calipers are pointing straight up so there is no possibility of air bubbles getting trapped. If the calipers are mounted on an angle, you will need to unbolt one ear from the bracket. Pivot the caliper so it points straight up and place a spacer between the pads to prevent the pistons from coming out of the housing. On calipers with four bleed screws you only need to use the bleeders pointing up. There is no need to use the bleeders pointing down.

Caliper Mounting Tech Tip

Brake calipers should be mounted square with rotor to prevent excessive piston knock-back and uneven pad wear. While looking at brake area, have someone apply brakes. Caliper should not move (square itself to rotor): only the pistons and pad should move. If caliper is not parallel with rotor, shims should be used between mounting bracket and caliper ears for proper alignment. Caliper brackets should be strong enough not to deflect under heavy braking. All caliper mounting bolts should be of the highest quality and lockwired for safety.

Technical Tips

Caliper Piston Area Tech Tip

A caliper's piston area is calculated by finding the total piston area from one side of the caliper (this is true for a single piston caliper also). The graph provides the piston area for individual piston diameters. Note that differential piston bore calipers will be the total piston area of the different size pistons.

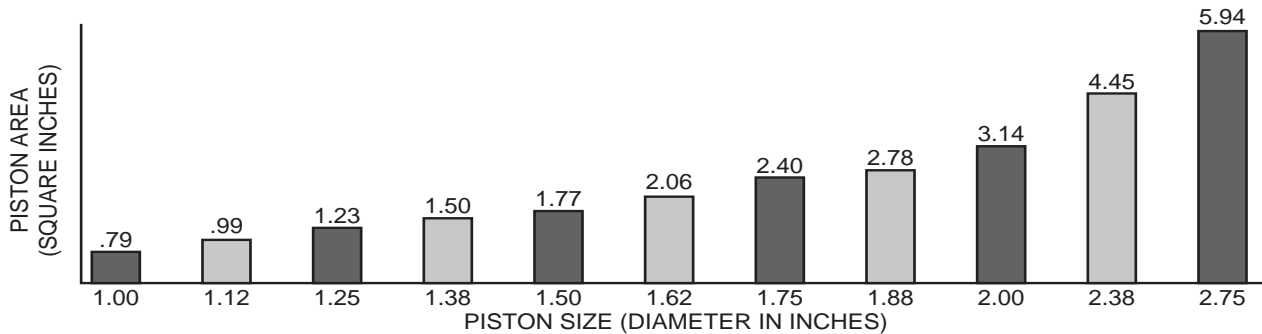

Example: For a typical six piston caliper (1.38", 1.38", 1.75" pistons), the effective piston area would be:
 $1.50" + 1.50" + 2.40" = 5.40$ square inches.

Caliper Rebuilding Tech Tip

If you race on a weekly basis throughout the year, you should disassemble your calipers mid-season and inspect the caliper seals for excessive wear or hardness caused by heat. Asphalt racers generally experience more heat and should do inspections more frequently, especially after racing on a track where high temperatures are reached. Asphalt race teams usually replace caliper seals after each race to ensure proper disc brake performance. Disassembly and replacement of the seals is a simple process and can prevent catastrophic brake failure.

Caliper Selection and Mounting Tech Tip

Many Wilwood extreme performance calipers are unidirectional because of the **differential piston bore design** (one end of the caliper having larger pistons than the other); the caliper must be mounted in a specific position relative to the rotor rotation. All Wilwood differential bore calipers are marked with a rotor rotation arrow on them. The caliper should be mounted so that the smaller piston end is closest to the rotor entrance and the larger piston end toward the rotor exit. The larger piston end provides slightly greater clamping force to compensate for pad taper that can occur under extended severe use applications. An improperly mounted caliper (reverse rotation) will cause increased pad taper and reduce overall braking efficiency.

Note that differential piston bore calipers cannot be used interchangeably from side to side - there is a left hand caliper and a right hand caliper. Also, calipers differ depending on whether the mounting is behind or in front of the spindle - this affects bleed screw position. Make sure to properly analyze these criteria when ordering and mounting or replacing differential bore calipers.

Pad Selection Tech Tip

Proper selection of a brake pad compound is critical to disc brake system performance. Each material has specific torque and wear characteristics relative to its operating temperature. Track conditions and driving style can also influence pad requirements. For best performance, final selection of pad material often requires evaluation at the track over a range of actual race conditions. Please reference the Wilwood web site at www.wilwood.com, or pages 24-25 in this catalog for descriptions of the various compounds available.

Pad Wear Tech Tip

As long as your pads are wearing evenly across the pad surface, the pads can be used almost down to the backing plate. Spacer plates may be added behind the pad backing plate as it wears so the caliper pistons will not have to be exposed to the abusive track dirt and grit. A regular check of the brake pads for excessive wear and taper is necessary to ensure proper disc brake performance.

Warnings

Disclaimer of Warranty

Purchasers recognize and understand that racing parts and equipment, such as disc brakes, hubs, etc. and all parts, inventory and services manufactured and/or sold by Wilwood Engineering, Inc. are exposed to many and varied conditions due to the manner in which they are installed and used. Purchasers and Wilwood Engineering, Inc. consciously desire to make their own bargain, irrespective of any court decision and purchasers agree upon good faith and in consideration for being allowed to purchase from Wilwood Engineering, Inc. said parts or services. Purchasers expressly acknowledge and understand that Wilwood Engineering, Inc. does not make any affirmation of fact or promise to purchaser, which relates to said parts, inventory, or services that becomes part of the basis of the bargain between Wilwood Engineering, Inc. and purchasers. Nor does Wilwood Engineering, Inc. make, or cause to be made to purchaser any description of the goods sold to purchaser, nor does Wilwood Engineering, Inc. make, or cause to be made, as part of the basis of the bargain with purchasers, any description or affirmation of fact concerning any sample or model of racing parts, and equipment inventory or service.

As further consideration for purchasers using Wilwood Engineering, Inc. racing parts and equipment any and all inventory and services, purchasers acknowledge that due to the differing conditions and circumstances under which all equipment and parts are installed and used, purchasers are not relying on Wilwood Engineering, Inc. skill or judgement to select or furnish the proper part or equipment. Purchasers expressly affirm they are relying upon their own skill or judgement to select and purchase suitable goods.

Wilwood Engineering, Inc. makes no warranties whatsoever, expressed or implied, oral or written, to purchasers. There is no warranty of merchantability made to purchasers. Wilwood Engineering, Inc. further excludes any implied warranty of fitness with respect to racing and equipment, any and all inventory and service.

It is expressly understood and agreed between purchasers and Wilwood Engineering, Inc. that as part of the bargain between Wilwood Engineering, Inc. and purchasers, and in consideration of doing business with each other, all purchasers take, select and purchase said racing parts, equipment, any and all inventory, or services from Wilwood Engineering, Inc. "as is" and "with all faults" and Wilwood Engineering, Inc. shall always provide purchasers with a full and complete opportunity to examine, at purchasers' leisure and convenience, any racing parts and equipment, any and all inventory, or services when purchasing or contemplating purchasing from Wilwood Engineering, Inc.

If, and in the event that purchasers expressly or impliedly cause representations, or statements or affirmations of fact contrary to this disclaimer of all warranties, expressed or implied, then purchasers agree to indemnify and hold harmless Wilwood Engineering, Inc. in the event of any claim, demand, or legal action against Wilwood Engineering, Inc. by any purchaser.

Purchasers understand and agree that no officer, director, employee, or salesman of Wilwood Engineering, Inc. has any authority to make any statement contrary to the terms of this agreement. On the contrary, Wilwood Engineering, Inc. disavows any statement contrary to what is herein above written.