

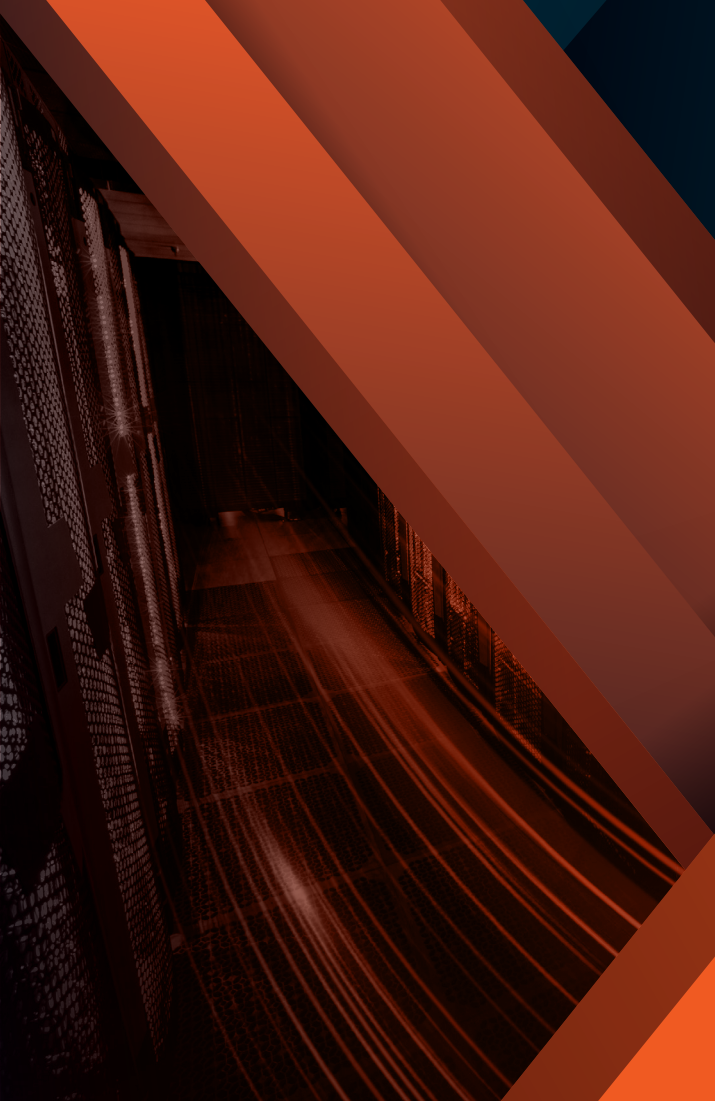

Leading the way in
Comms, Rail and
Procurement Industries

FATCOMMS.IO



SOLUTION EXAMPLE & CASE STUDY

WBT Harsh Environment Connectivity

- ▶ **Optical Fibre**
- ▶ **Hybrid Fibre/Power**
- ▶ **Plug & Play Systems**

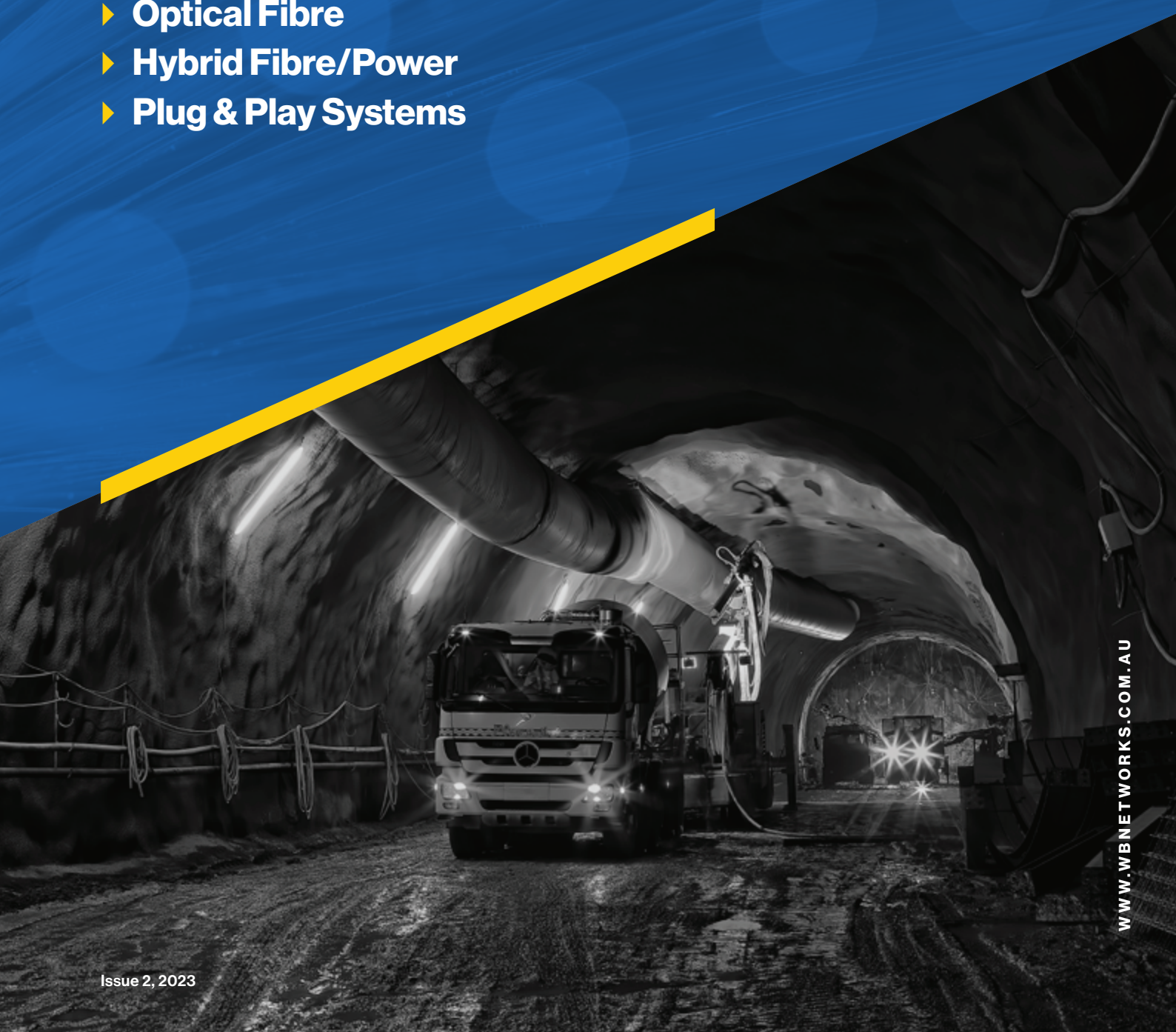

About Warren & Brown Technologies

Warren & Brown Technologies (WBT) was originally established in 1921 as a tool-making factory in Melbourne, Australia. Since then, the company has evolved to become a leader in precision tools and telecommunications network connectivity infrastructure.

WBT has remained wholly Australian owned and operated for over 100 years. This commitment to the local design, manufacturing and technology industry has created hundreds of jobs and world leading solutions.

The main facility in Maidstone, Melbourne currently comprises of over 48,000sqm of office, manufacturing, R&D and warehouse space. In addition, WBT has expanded operations to include a presence in other states around Australia.

Recently the company has also expanded its global reach by opening up many regional offices and manufacturing facilities. These operations are overseen and integrated with WBT Australia.

We pride ourselves on being a global leader in the supply and manufacture of optical fibre and copper communications equipment, as well as torque setting equipment for automotive and industrial applications.



Australian
Owned and Operated



300+
Employees



3
Manufacturing facilities



6
Sales offices



Worldwide
Distribution

We pride ourselves on being a global leader in the supply and manufacture of optical fibre and copper communications equipment, as well as torque setting equipment for automotive and industrial applications.



Our Capabilities

As an innovative company, Warren & Brown Technologies is committed to designing and developing new solutions, as well as striving to go above and beyond to meet and exceed the needs of our customers.

With state of the art facilities, manufacturing plants and an agile R&D department, we have a fast product development cycle to produce solutions in weeks, not months.

Being a supplier to the major telecommunications network operators in Australia and around the world for over 32 years, we have been recognised for our expertise in the telecommunications industry by being selected as an official supplier to the Australian National Broadband Network (NBN). In addition to being a long-term supplier to Telstra, other leading carriers and for many structured cabling networks.

We provide the ideas and solutions behind the telecommunications infrastructure which powers our connected society. By investing in new technologies such as 3D printing, WBT is able to offer innovative manufacturing, solution design and deliver new concepts.

Warren & Brown Technologies serves a variety of fibre optic industries with high-quality products and services for the harsh environments. Going far beyond simply selling top quality fibre products, we are an engineering and manufacturing company that takes pride in providing you with exactly the right solution for your particular application.

If you are setting up, moving, or improving a facility employing fibre and/or data system, we can deliver the expertise and practical guidance to plan, implement, and document the project in an efficient, well organized manner with minimal disruption to your business.



Military



Aerospace



Industrial



Mining



Transportation



Oil & Gas



Broadcast



Manufacturing



Marine



Energy



Solar



Medical

Markets we service

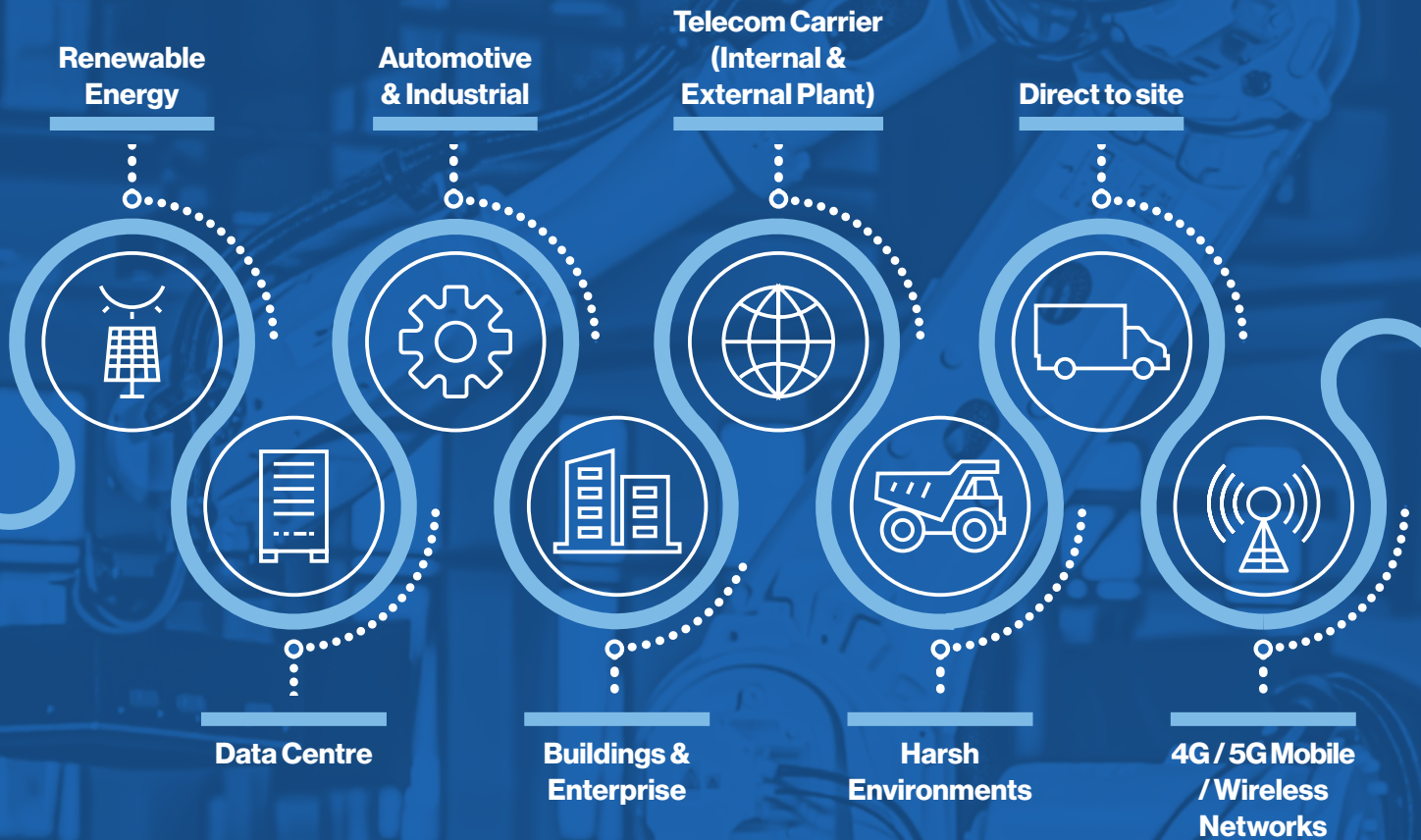

Product Design & Manufacturing

innovative & world leading solutions



Technology Leadership

telecom, data centre & enterprise networks



Fast Product Development Cycle

weeks not months



Quality Products & Systems

ISO 9001 third party certified



Proven Track Record

official supplier to NBN & Telstra



Supply Chain Management

progressive logistics solutions

Harsh environment applications



Mining, Oil & Gas

Our products are designed and manufactured to provide the necessary performance, ruggedness and durability to support the most demanding applications, designed specifically for the mining industry. Our multi-channel fibre optic connectors and custom made cable assemblies are used on tagging and tracking systems, automation systems, WiFi, OT systems and other applications.

Our cable assemblies and enclosures are specially designed and ideally suited for the harshest mining applications.



Military & Defence

Our fibre optic solutions offer precise optical alignment, ruggedised packaging and numerous options for customisation.

We offer pre-assembled and pre-deployed off the shelf products, available immediately for customer installation. If you need a new, unique fibre solution, we will custom design and manufacture product solutions to meet your harsh environment requirements.



Broadcast

Our highly reliable rugged multi-channel, hybrid and expanded beam connectors easily connect in the field with minimal signal loss. The connectors are specifically designed for real-time transmission of HD signals with the ability to withstand harsh demands.

In addition to ruggedised connector systems, we have easy to deploy, yet extremely tough fibre cables designed to survive high-traffic areas. Our cable assemblies are optimised to withstand the rigours of installation challenges.



Manufacturing & Industrial

Warren & Brown Technologies provides connectivity solutions for manufacturing, industrial and other networks, where the quality of fibre optic and copper structured cabling industrial components are essential for ensuring network reliability and uptime.

Supporting Information Technology (IT) or Operational Technology (OT) networks, we are able to develop the best solution for your unique industry's rugged demands.



Expanded beam

Expanded beam technology uses expanded and collimated beams to couple optical fibres without any contact. It could allow for optics to be used in areas that have been quite restrictive due to the presence of damage or contamination at the fibre end. Hermaphroditic connector design enables fast deployment by daisy-chaining multiple cable segments.

- Advanced expanded beam technology
- Rugged field-deployable fibre optic connector
- Custom configurations available
- Environmental sealing (IP68)
- Very high resistance to vibration, shock, environmental effects, dust, and debris
- 2, 4, 6 multi channel connectors
- Compatible and intermatable with other brands



Cable reels with preterm cable

Warren & Brown has a wide range of fibre optic and hybrid cable assemblies/harnesses.

We document each custom cable assembly we build with a product definition package, which includes a detailed drawing with a bill of materials, as well as labelling, testing, and packaging requirements to ensure consistency from build to build.



Din Rail mount enclosures

DIN rail mounted fibre enclosures feature a slim and compact design while providing maximum fibre density. Can be installed in control cabinets, indoor/outdoor cabinets, or directly onto DIN mounting rails, and are an ideal solution for either industrial, mining, power or other harsh environment telecom networks.

Enclosures also feature rigid metal construction and openable side panels. Options including splice/patch, patch only and pre-terminated enclosure solutions. Connectivity options include either MPO, LC, LC/A, ST, SC or SC/A adaptors.



CAT6 & CAT6A outdoor cable

The CAT6 and CAT6A twisted pair cables are suitable for outdoor use and with specialised sheath options, as well as gel-filled options. Available with shielded or unshielded conductors.

Furthermore, twisted pair cable assemblies with RJ45 connectors and ruggedised bulkhead fittings can also be supplied.



MUTO's

Multi-User Telecommunication Outlets (MUTO) are small and designed to enable the direct terminations of multiple horizontal fibres and UTP copper cables in a common, permanent location, such as a column, wall or permanent furniture, or close to a cluster of work areas.

Provided with clear plastic design cover for added security, knock-out adaptors and cable openings to keep insects or rodents from entering unused ports, cable entry holes for wall-mounted and concealed cable entry, provision of anti-tamper seals & security lock, as well as cable management clips for managing internal cable routings. The MUTO boxes vary in colour (defence colour codes for secure cabling). Interchangeable faceplates are available for different types of connector configurations.

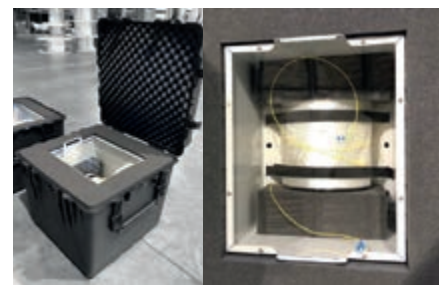

Ruggedised fibre reel cases

Custom made optical fibre test reels, and launch spools are custom made to specified lengths and can be securely stored in a sturdy outer case. Additional protection can be provided by deploying these cases in a Pelican case, ready for field deployment.



IP Fibre connectivity

The harsh environment (IP) range of connectors are designed to be used outdoor and provide many years of reliable service. They incorporate a bayonet system which enables quick and reliable installation. Generally supplied as a factory pre-term solution, allowing for plug and play deployment on-site.

- Cost-effective solution
- IP water immersion and dust protection for harsh environment
- Wide range of operational temperature for outside plant -40°C / 70°C
- Compatible with a wide range of cables
- Chemical Resistance
- LC and MPO connector options
- Specialised harsh environment cable options
- Manufactured to exact length with specified cable and connector configurations



IP Hybrid Connectivity

One single connector provides power and optical connectivity to your equipment. It is generally supplied as a factory pre-term solution, allowing for plug and play deployment on-site.

- Combined power and fibre in ONE connector
- Simplify your connectivity with reduced cable and connectors
- Minimize interface footprint of your equipment
- Provide reliable protection in outside plant, Rating IP-68
- Cost-effective with easy termination
- Tamper proof with Safe Lock
- Reduced and simplified connectivity
- DC Power distance - 1km (48V, 40W over 12 AWG cable)
- IP LC and Power, and MPO LC and power options
- Specialized harsh environment cable options
- Suitable for Wi-Fi, CCTV or other OT requirements
- Compatible solution with breakout cables and devices, bulkhead and adaptor fittings, etc



Tactical and ruggedized cable

Tactical fibre optic cable is ideal for use in the myriad of harsh environmental situations encountered during military, mining, petrochemical, and industrial operations. This non-metallic cable's compact size and reduced weight make it easy to transport and deploy. It is strong enough to survive outdoors lain directly on the ground and endures severe conditions while being retrieved and reused repeatedly. The cables have been tested and are in use in military communication applications worldwide.



Tactical and ruggedized cable assemblies

Extremely rugged and lightweight tactical multi-channel fibre optic cable assembly designed for Broadcast, Military and Pro-Audio applications. All cable assemblies come pre-terminated and custom-designed to your unique specifications, allowing for an easy installation.

With thousands of interchangeable components such as fibre cabling and fibre optic connectors, we proudly offer custom assembly solutions. Choose cable length, channel count, connector type (including but not limited to SC, LC, ST, FC, MT-RJ, and MU).

WBT Mining application plug and play solution

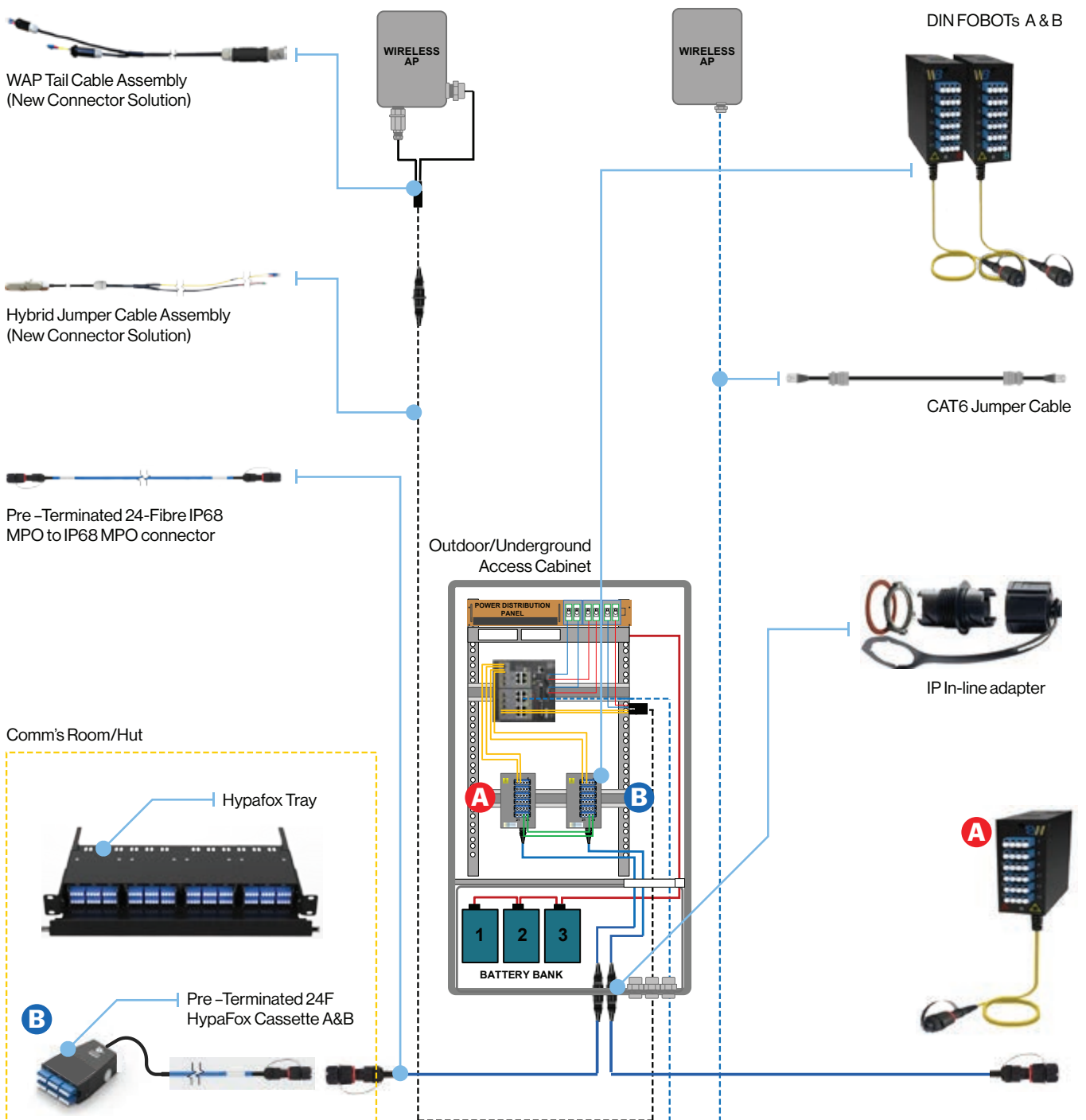

Hybrid Jumper Cable Assembly Detail Overview

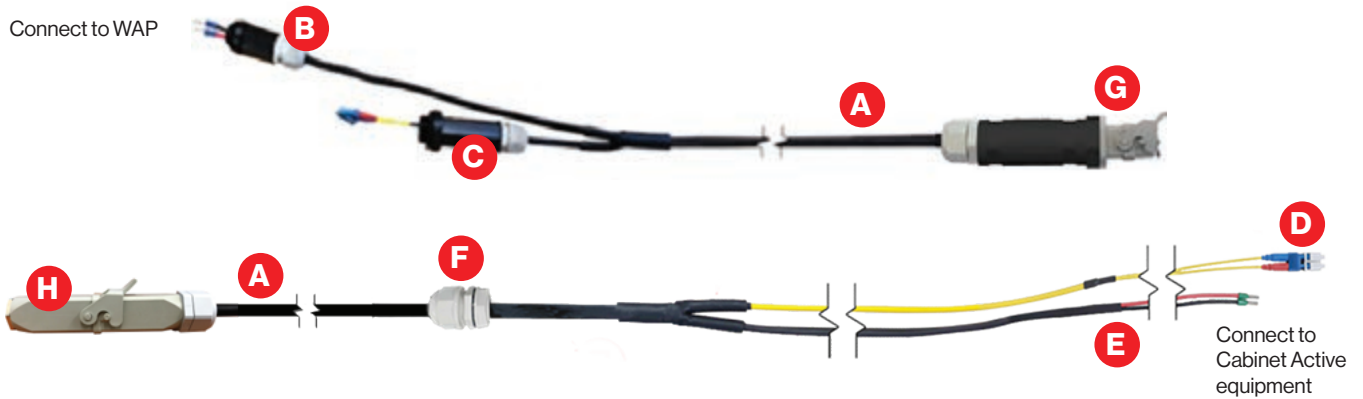

IP Connector Component Definition

A 2 Fibre & 2 Copper Hybrid Cable

- 2x copper conductors (insulation Ø3.25mm)
- Water-blocking glass yarn with rip cords
- LSZH inner jacket with FRP strength elements and aramid yarn (Ø2.8mm)
- 900 µm tube with up to 4 fibres
- LSZH outer jacket

B DC Power Connector

- DC Power Pin connector
- DC Power Cable gland extension barrel

C Optical Connector

- LC Duplex connector
- Optics Cable gland extension barrel

D LC Duplex connector

- LC Duplex connector
- DC Power Pin connector

F M20 Cable Gland

G New IP Adapter

- Connector Dust Cap
- IPONE Adapter housing
- Optical LC Adaptor
- DC Power Female Socket

H New IP Connector

- Connector Dust Cap
- IP Connector
- Optical LC Connector
- DC Power Male Socket

Hybrid Jumper Cable Assembly Detail Overview

Hybrid Tail Cable Assembly – New IP Adapter Design

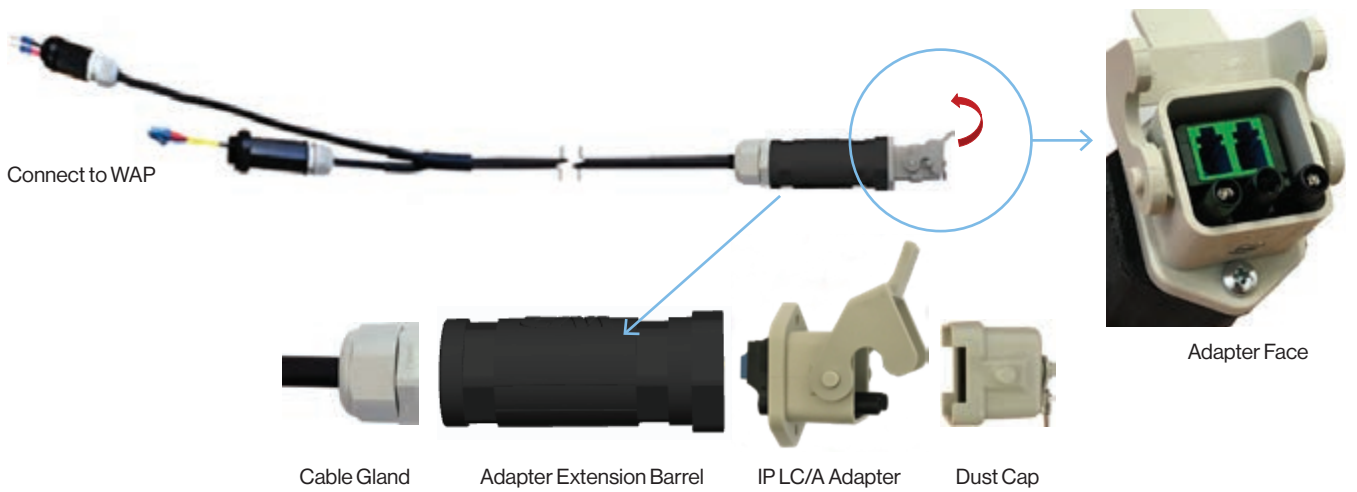

Hybrid Jumper Cable Assembly – New IP Connector Design

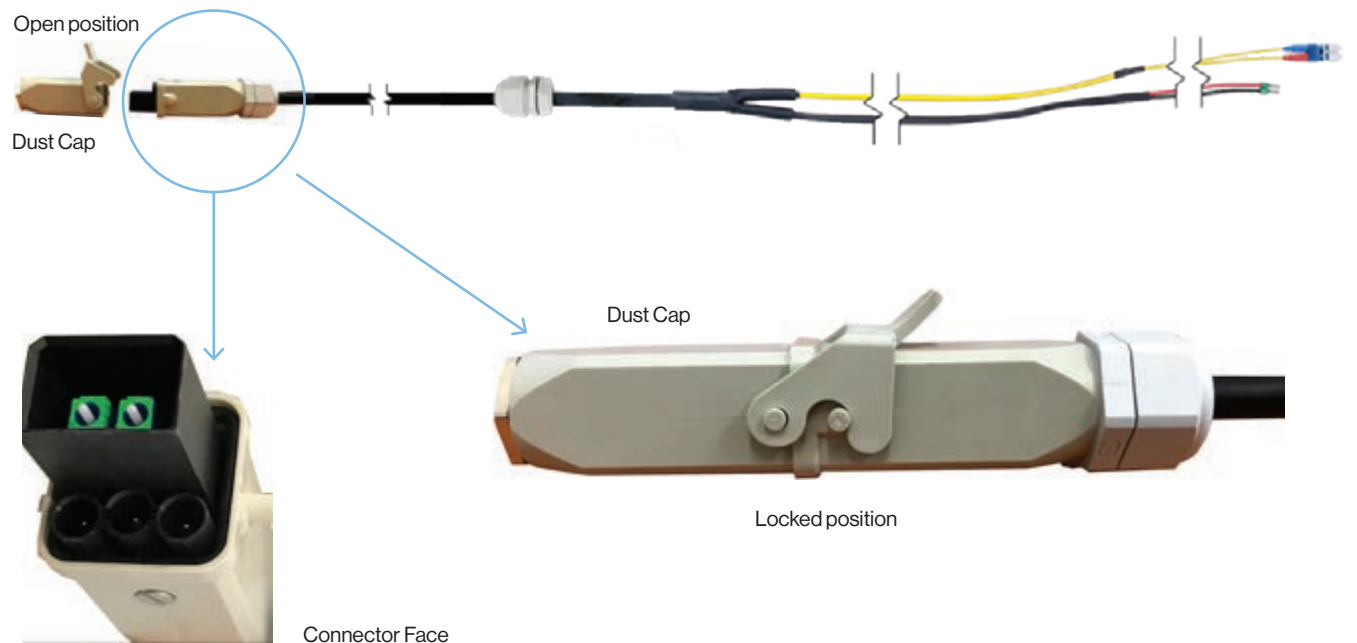

Connected Hybrid Tail and Jumper Cable

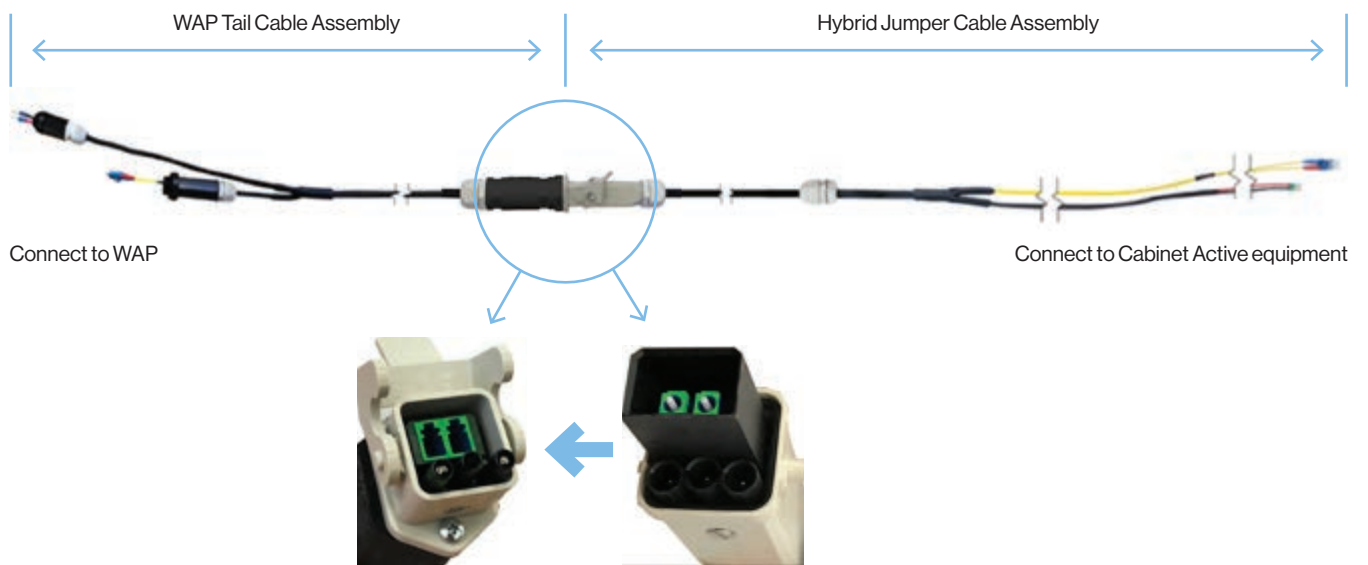

WBT Solutions

1X24F – IPMPO to IPMPO Connectivity

Sample Link : TH-LV MSB&CP to ACC FANS AC&DB Fibre Nodes

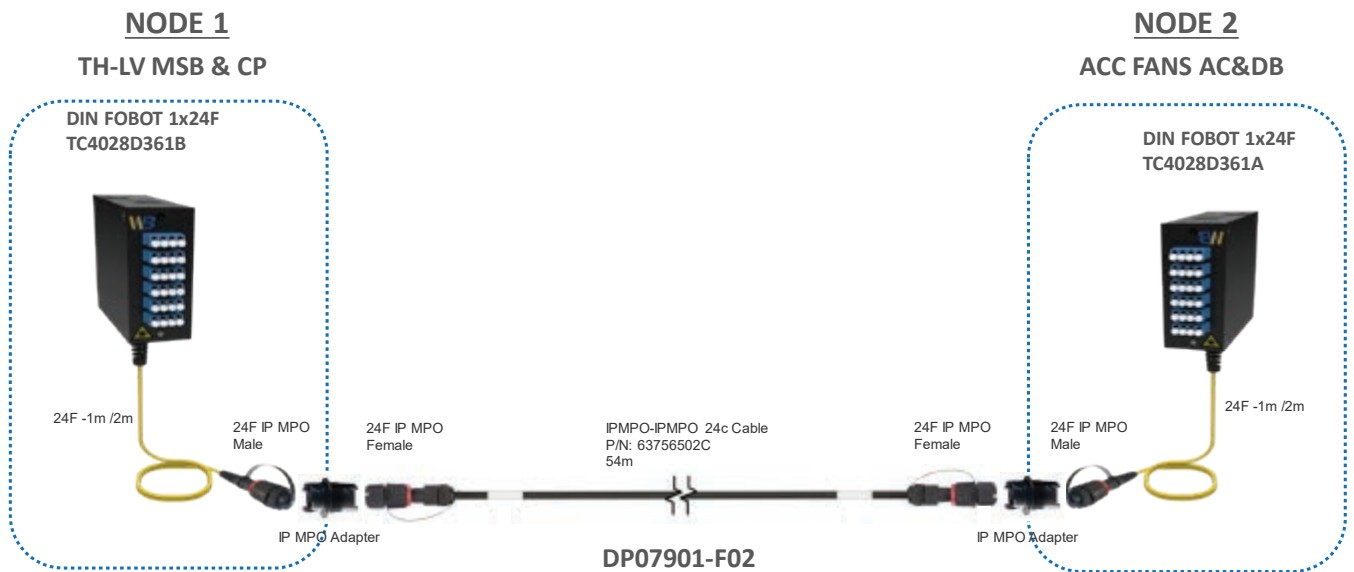

1X12F - IPMPO to IPMPO connectivity

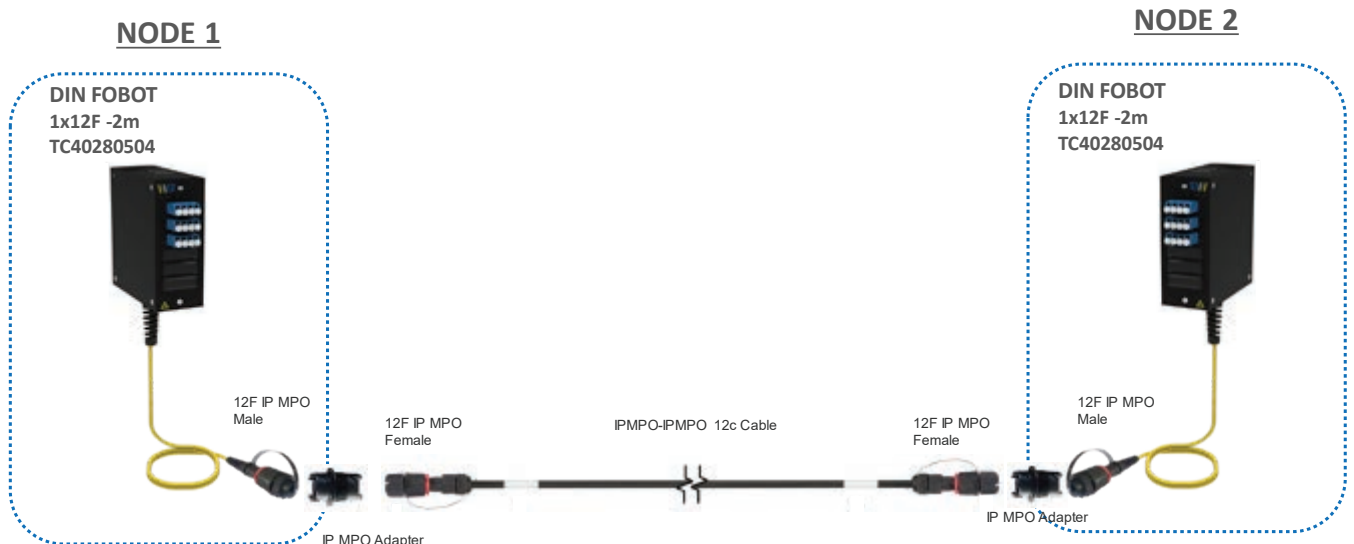

2x12F IPMPO to 2x1x12F IPMPO connectivity

Sample Link : 1A FCP to 1A TDP & 1A FCCP Fibre Nodes

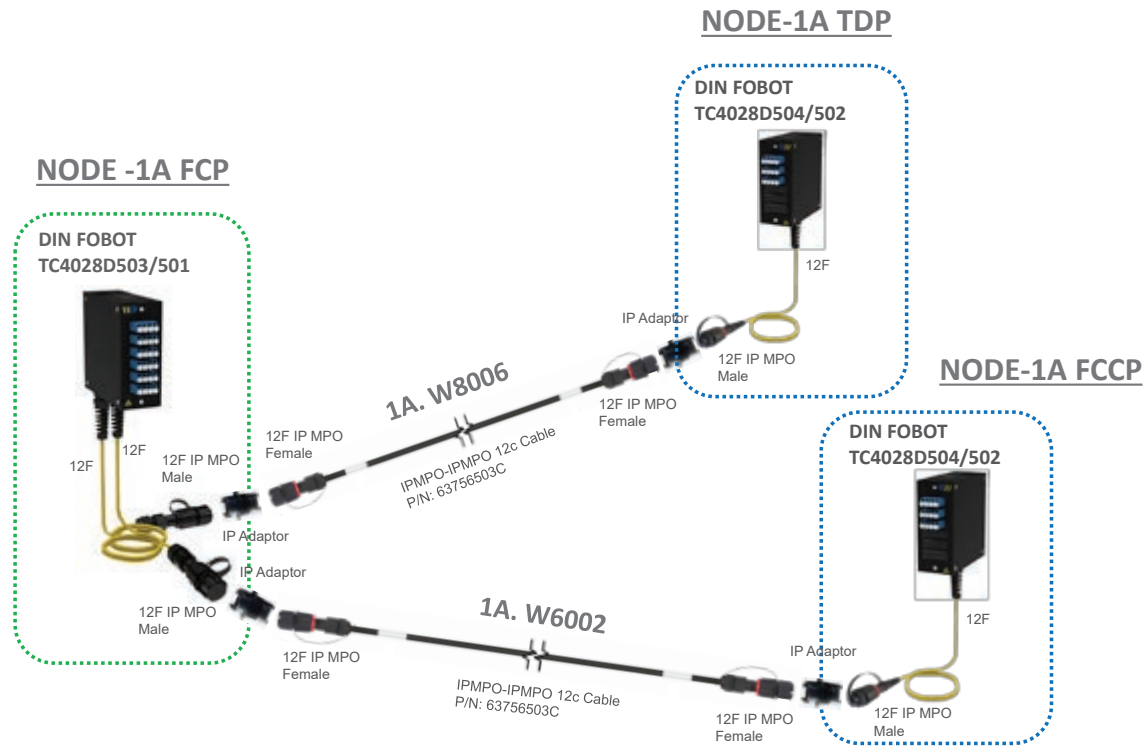

1x24F IPMPO to 1x24F IPMPO connectivity

Sample Link : TH-LV MSB&CP to Site Server Room Fibre Nodes

NODE -TH-LV MSB&CP

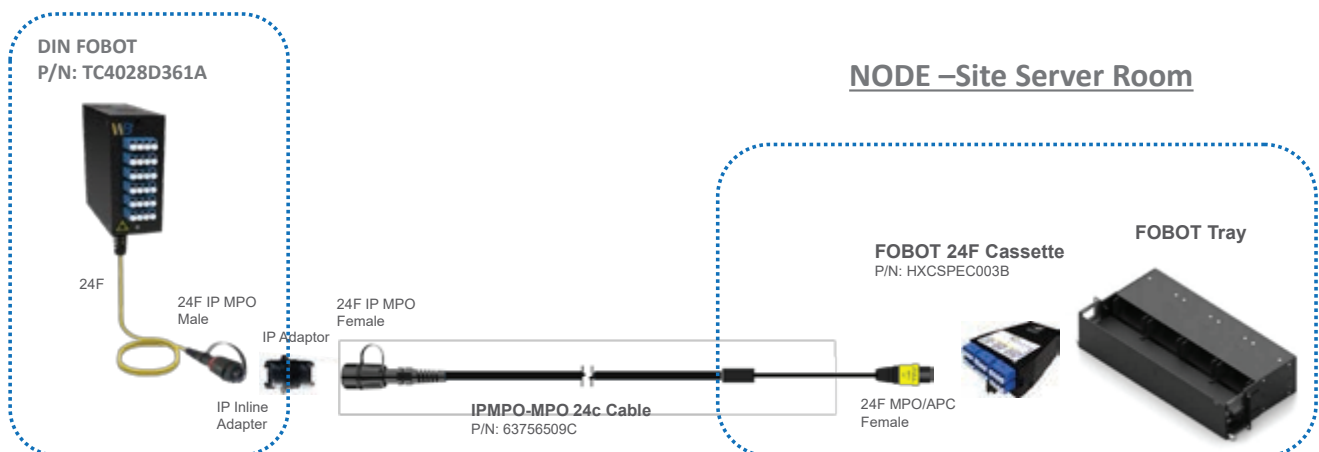

DIN FOBOTs



DIMENSIONS	WEIGHT	MATERIALS	COLOUR
50mm L x 125mm W x 125mm H	±300g	Aluminium (Body, typical) Mild Steel (Body, BHP requirement) Plastic	Black

Use/Application

This WBT DIN rail mounted enclosure is a patch-only model with 6x LC UPC Quad front panel adapters. The enclosure is supplied with pre-terminated LC UPC to MPO Ultra Low Loss Male, 24f, 2-metre tail cable assembly supported by a spring-type cable gland installed at the bottom exit hole of the enclosure.

The unit has an openable side panel for service and general access to the housed pigtailed connections. The compact design makes it perfect for limited-space installation (e.g. Equipment/Control Cabinets).

Each unit is made from durable mild steel, ensuring a very high degree of protection for working services.

Benefits & Features

- Compact, versatile design; DIN rail mounted
- Patch-only function
- 6x pre-installed LC UPC Quad front panel adapters
- Supplied with LC UPC to MPO 24-fibre tail cable
- MPO 24-F connector housed in an IP68 bayonet style male bulkhead adapter
- Openable side panel
- Pre-punched cable entry/exit holes on either top or bottom to suit various installation requirements



DIMENSIONS	WEIGHT	MATERIALS	COLOUR
50mm L x 125mm W x 125mm H	±300g	Aluminium (Body, typical) Mild Steel (Body, BHP requirement) Plastic	Black

Use/Application

This WBT DIN rail mounted enclosure is a Patch-only model with 3x LC UPC Quad front panel adapters for 12F capacity. This FOBOT enclosure is supplied with pre-terminated LC UPC to MPO Ultra Low Loss Male, 1x12F, 1 or 2 metre tail cable assembly supported by a spring-type cable gland installed at the bottom exit hole of the enclosure. This FOBOT can accommodate up to 24F capacity. Unused adapter ports are covered with the blanking plug that can be utilised for future expansion.

The unit has an openable side panel for service and general access to the housed pigtailed connections. The compact design makes it perfect for limited-space installation (e.g. Equipment/Control Cabinets).

Benefits & Features

- Compact, versatile design; DIN rail mounted
- Patch-only function
- 3x pre-installed LC UPC Quad front panel adapters
- Supplied with 1x LC UPC to MPO 12F-fibre tail cable
- MPO 12-F connector housed in an IP68 bayonet style male bulkhead adapter
- Openable side panel
- Pre-punched cable entry/exit holes on either top or bottom to suit various installed requirements.



DIMENSIONS	WEIGHT	MATERIALS	COLOUR
50mm L x 125mm W x 125mm H	±300g	Aluminium (Body, typical) Mild Steel (Body, BHP requirement) Plastic	Black

Use/Application

This WBT DIN rail mounted enclosure is a Patch-only model with 6x LC UPC Quad front panel adapters. The enclosure is supplied with pre-terminated LC UPC to MPO Ultra Low Loss Male, 2 x 1x12F, 1-metre tail cable assembly (WBT P/N 63712224C), supported by a spring-type cable gland installed at the bottom exit hole of the enclosure.

The unit has an openable side panel for service and general access to the housed pigtailed connections. The compact design makes it perfect for limited-space installation (e.g. Equipment/Control Cabinets).

Each unit is made from durable mild steel, ensuring a very high degree of protection for working services.

Benefits & Features

- Compact, versatile design; DIN rail mounted
- Patch-only function
- 6x pre-installed LC UPC Quad front panel adapters
- Supplied with two (WBT P/N 63712224C) LC UPC to MPO 1x12F-fibre tail cable
- Each MPO 12-F connector housed in an IP68 bayonet style male bulkhead adapter
- Openable side panel
- Pre-punched cable entry/exit holes on either top or bottom to suit various installation requirements

FOBOT Cassettes

FOBOT CASSETTE 24F MPO/A to 24F LC/UPC (Version A)

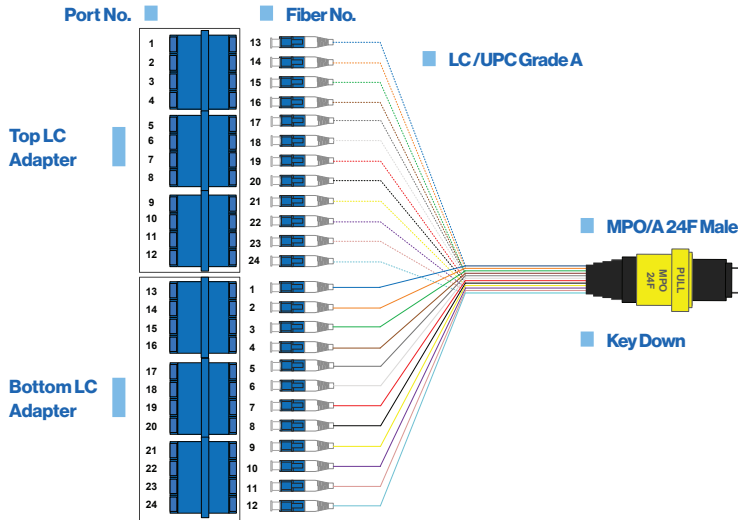

P/N: HXCSPEC003A

CASSETTE 1X24FMPO/A - LC/UPC



Cassette Faceplate

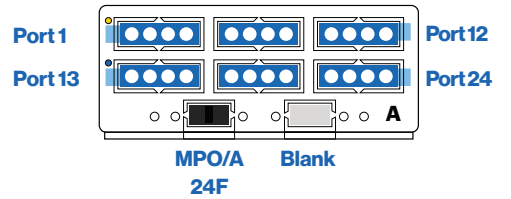

Important note :

The fibering configuration inside of this cassette are in inverse positions ; where in fiber no. 13 connect to port no.1 of the LC adapter, 14 to 2 and fiber no.1 to port 13 , 2 to 14 and so on.

FOBOT CASSETTE 24F MPO/A to 24F LC/UPC (Version B)

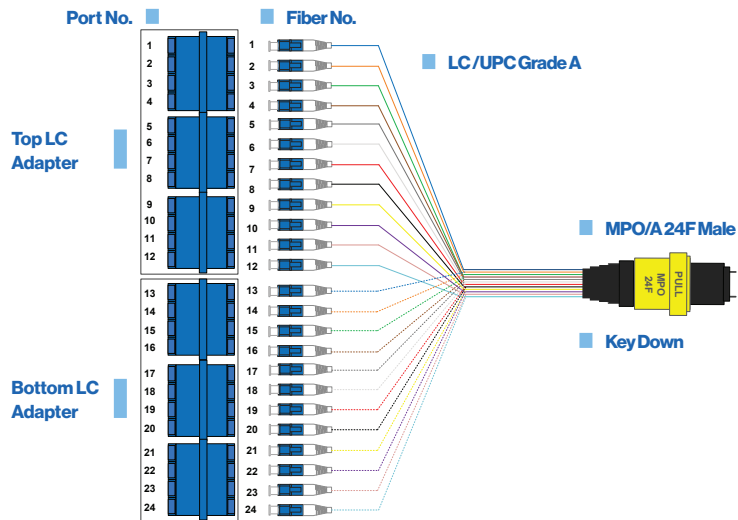

P/N: HXCPEC003B

CASSETTE 1X24FMPO/A - LC/UPC



Cassette Faceplate

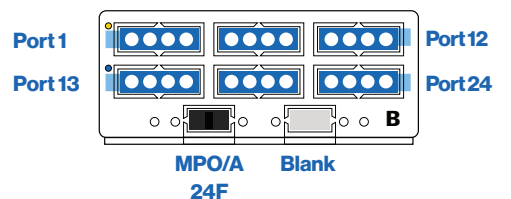

Important note :

The fibering configuration inside of this cassette version B are in straight positions i.e., port 1 to Fiber no.1 and so on.

Use with Hyperfox 1RU chassis

Pre-Terminated Fibre Cables

Pre-Terminated 24-Fibre G657A2 SM Low-Loss IP68 MPO to IP68 MPO connector

24F Core SM Outdoor Cable



Cable Cross Section



Schematic Drawing



Cable Specification

NUMBER OF FIBRES	STRENGTH MEMBER	OUTER SHEATH	CENTRAL LOOSE TUBE	WEIGHT
24-Core	Aramid yarn	PE with anti-termite additive & UV	PBT	40kg/km (w/o connectors)

Pre-Terminated 12-Fibre G657A2 SM Low-Loss IP68 MPO to IP68 MPO connector

12F Core SM Outdoor Cable



Cable Cross Section



Schematic Drawing

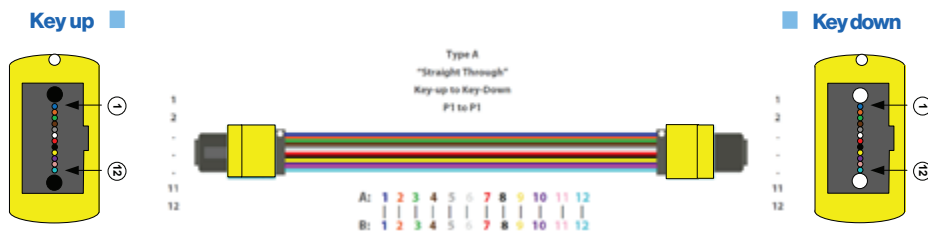

Cable Specification

NUMBER OF FIBRES	STRENGTH MEMBER	OUTER SHEATH	CENTRAL LOOSE TUBE	WEIGHT
12-Core	Aramid yarn	PE with anti-termite additive & UV	PBT	40kg/km (w/o connectors)

Pre-Terminated 24-Fibre G657A2 SM Low-Loss IP68 MPO to MPO connector

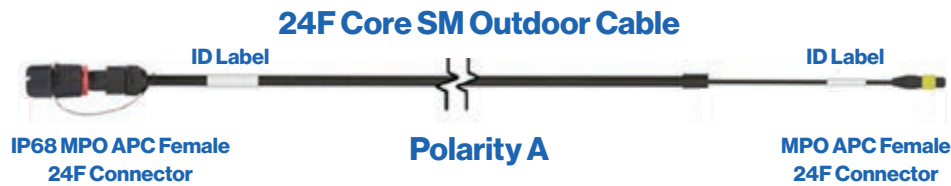

Cable Cross Section

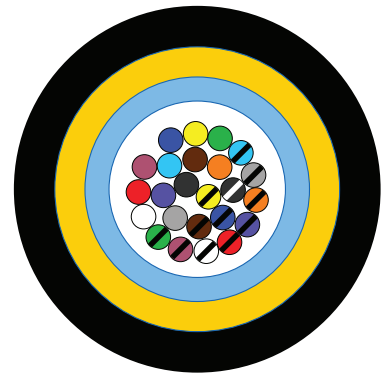

Schematic Drawing



Cable Specification

NUMBER OF FIBRES	STRENGTH MEMBER	OUTER SHEATH	CENTRAL LOOSE TUBE	WEIGHT
24-Core	Aramid yarn	Material Diameter	Material Diameter	40kg/km (w/o connectors)
		PE with anti-termite additive & UV	PBT	
		Ø7.0 ±0.3mm	Ø3.0 ±0.2mm	



“This is the only fibre solution I ever want to use in future projects – it is flexible, ruggedised, reliable, and cost-effective - a total game changer!”

– Huon Kendall, Manager Information Services at RayGen



Fight Climate Change with RayGen's Clean Sustainable Energy Solution

In a global race to fight climate change, Australian solar-storage technology company RayGen has a clean sustainable energy solution set to change the way we think of the energy transition on a global scale.

Founded by Dr. John Lasich in 2010, RayGen's vision is to accelerate the global transition to a more renewable energy alternative. The technology works by capturing the rays from the sun from a field of automatically controlled mirrors which direct the concentrated light into a central tower where PV Ultra modules convert it into electricity.

Since its early beginnings, RayGen has set itself apart from competitors, with an energy efficiency that no other electro-thermal energy storage system has been able to achieve. RayGen's unique PV ultra-technology makes cost-effective solar power-plug storage possible by co-generating electricity and heat, feeding energy from sunlight into an electro-thermal storage cycle at an energy efficiency rate of nearly 90% (one-third electricity and two-thirds heat). Then, with PV Ultra's by-product heat, an efficiency rate of 70% is achievable.

Communications services and telecommunications hardware is also required to enable this technology. The ICT infrastructure required for this project needed to be fast to deploy and suitable for harsh environments. This was achieved by utilising Warren and Brown Technologies (WBT) FOBOTs and IP rated cable and connectivity solution, providing a true plug-and-play deployment.

"All the cables and fobots were supplied from WBT, so there was no requirement for any on-site fibre termination expertise," says Huon Kendall, Manager Information Services at RayGen.

The ICT system design was done in collaboration between both parties, with the specified hardware deployed with onsite training and customer support.

"Thorough planning was needed to ensure all conduits and cable lengths were accurately captured prior to manufacture. Immediately after carefully hauling the cables through conduits, we were able to inspect and connect the cables to the fobots," says Huon.

"We had a 100% success rate (zero defects) with 23 separate cables (using 12 and 24 cores) for a combined total of 3.8km of single mode fibre connecting across 27 fobots on the site. Within an hour of hauling each cable, we had a fully tested and commissioned fibre connection ready to connect to network devices," says Huon.

Therefore, wanting an Australian manufacturer and supplier that could provide on-site technical assistance, WBT was able to support the deployment of a small project in the Victorian town of Mildura where no terminations or splicing were required.

RayGen is growing rapidly with investment from AGL, global energy majors, and the Australian Renewable Energy Agency (ARENA).

The WBT team would like to thank Huon Kendall and the team at RayGen for their dedication to our program and look forward to more opportunities ahead.

WARREN & BROWN TECHNOLOGIES PTY LTD

**108 Mitchell Street,
Maidstone, Victoria 3012**

Phone: (613) 9317 6888

Fax: (613) 9318 6091

Email: sales@wbt.com.au

Europe

WTB Europe BV

Energieweg 45,
1271 EC Huizen,
The Netherlands

Phone: +31 35 2085653

Email: htovar@wbt.biz
dkoning@wbt.biz

Philippines

Warren & Brown Fiber Systems Corporation

BDG Building 2, Block 1, Lot 1,
Solid Street, LIIP, Mamplasan,
Binan 4024, Laguna,
Philippines

Phone: +63 2 584 4617
+63 2 584 4510

Fax: +63 49 508 0011

Email: deoperff@
warrenandbrown.com.au

Vietnam

Warren & Brown Technologies Pty Ltd

R.02-11, 2nd Floor, D2 Building,
Mandarin Garden, Hoang
Minh Giam Str., Cau Giay
District, Hanoi 10000, Vietnam

Phone: +84 4 6664 3388

Fax: +84 4 6664 3888

Email: wbtvn@
warrenandbrown.com.au

New Zealand

AC-WB Technologies

7 Old Wairoa Road, Papakura,
Auckland, New Zealand

Phone: +64 9 302 2668

Fax: +64 9 302 2678

Email: sales@
actechnologies.co.nz

New South Wales

JCS-WB Technologies Pty Ltd

Unit 2, 2 Holker Street,
Newington, NSW 2127

Phone: +61 2 8878 6600

Fax: +61 2 9808 2622

Email: sales@jcs-wbt.com.au





Kyle Lancaster

 +61 480 399 917

 kyle@fatcomms.io

Nathan Smith

 +61 433 814 100

 nathan@fatcomms.io

 office@fatcomms.io

 Melbourne, Victoria, Australia
Geelong, Victoria, Australia

ABN

41 672 509 394

Insurance

Public and Products Liability
Insurance \$20M. Professional
Indemnity Insurance \$5M
Workcover Insurance

FATCOMMS.IO

