



HARBIL 5G High Speed Paint Mixer with 8-Minute Timer

End User Guide

Part No: 24018
Rev. I 08.16





Your

customers have a vision,
you want to make it happen, and

Fluid Management can give you the answer.

Fluid Management is a global leader in dispensing
and mixing equipment used in the paint industry, as

well as, specialized equipment for the food and beverage,

chemical, health and beauty, and home improvement industries.

Located in the suburbs of Chicago, Illinois, Fluid Management is

a United States owned and operated company with historical roots

to the paint industry dating back to 1927. In 1996, IDEX Corporation

purchased Fluid Management giving the organization the financial

wherewithal and global footprint of a large organization while still maintaining

its deep values and history.

As industry leaders, Fluid Management provides trend-setting creativity in the
design, products, and services it offers. United with FMDirect, our nationwide

service team, we provide after-sales support around the clock—when you need

them. Being factory-direct employees, FMDirect technicians are experts on Fluid

Management equipment and understand customer needs from start to finish.

The combination of leading edge technology, excellent service and support, and
a company prepared for the future's ever-changing business environment makes

Fluid Management an ideal partner to assist in providing solutions to your business

needs. Thank you for putting your trust in Fluid Management products and making

us part of your customer's vision.



©2014 Fluid Management as published work all rights reserved.

Under the copyright laws, this material may not be copied, in whole or in part, without the written consent of Fluid Management.

Your rights to the software are governed by the accompanying software license agreement.

Use of Fluid Management trademarks, service marks, or logos for commercial purposes without the prior written consent of Fluid Management may constitute trademark infringement and unfair competition in violation of federal and state laws. Fluid Management, FMDirect, ColorPro, DVX, Harbil, Blendorama, Accutinter, Duraflo, Fast & Fluid Management, GyroDispenser, Infina, MicroTint, TintMaster, V1, and VR1 are trademarks of Fluid Management, registered in the U.S. and/or other countries.



Every effort has been made to ensure that the information in this guide is accurate. Fluid Management is not responsible for printing or clerical errors.

Fluid Management

1023 Wheeling Road
Wheeling, Illinois 60090-5776 USA
800-462-2466
<http://www.fluidman.com>

Published in the United States.

Mention of third-party products is for informational purposes only and constitutes neither an endorsement nor a recommendation. Fluid Management assumes no responsibility with regard to the performance or use of these products.

Contents

Safety Information

- 4 Mixer Warning Labels
- 5 Safety Notice Information

Introduction

- 6 Product Descriptions
- 7 Equipment Maintenance Log
- 8 Spare Parts Order

Unpacking Directions

- 9 Inspect the Crate for Damage
- 9 Unpacking and Setup

Electrical Conditions

- 10 Grounding
- 10 Danger

Aligning and Leveling Mixer

- 11 Aligning the Struts
- 11 Leveling
- 12 Remove Shipping Inserts

Getting to Know Your Paint Mixer

- 13 General Locations
- 14 Control Panel
- 14 Revisable Door

Important Information

- 15 Warnings
- 15 Cautions

Basic Operation

- 16 Basic Operation Procedure

Operational Test

- 19 Operational Test Procedure

Maintenance Procedures

- 20 General Lubrication
- 21 Super-Struts Lubrication

Troubleshooting

- 22 Troubleshooting Tables

Servicing and Repair

- 26 General Information
- 26 Safety Procedure

Opening Mixer

- 27 Remove the Exterior Panels

Removing Shake Frame

- 28 Removing Shake Frame Procedure
- 30 Remove the Counterweights

Testing Shake Motor

- 32 Testing Shake Motor Procedure

Changing Shake Motor

- 33 Changing Shake Motor Procedure

Changing the V-Belt

- 34 Changing the V-Belt Procedure

Removing Circuit Board

- 35 Removing Circuit Board Procedure

Installing Rubber Pads

- 36 Installing Rubber Pads Procedure

Replacing/Adjusting DC Motor

- 38 DC Clamping Motor Replacement/Adjustment

Adjusting Clamping Force

- 39 Clamping Force Adjustment Procedure

Reversing Door

- 42 Reversing Door Procedure

Replacing Super-Struts

- 44 Removing the External Panels
- 44 Removing the Super-Struts
- 47 Installing the Super-Struts

Replacing Crankshaft

- 50 Access the Crankshaft
- 50 Remove the Crankshaft
- 51 Install New Crankshaft

Reassembling Mixer

- 53 Reassembling Mixer Procedure
- 54 Test Procedure

Parts Section

- 55 Sheet and Metal Outer Frame
- 59 Control Box Assembly
- 61 Inner Frame
- 63 Shake Frame
- 65 Clamping Motor Assembly
- 69 Top Plate Assembly
- 70 Crankshaft Assembly

Warranty

- 76 Paint Equipment Limited Warranty

Safety Information

Safety Information

Mixer Warning Labels

You should become familiar with important warning labels which are affixed to the mixer, as well as the symbols which appear throughout this manual. These warnings have been included to help you safely perform your job.

Please read all warning labels that are on the mixer. Keep them clean so they are easy to read. If the warning labels become damaged or unreadable, new labels can be purchased from Fluid Management. See the parts list in the back of the manual for ordering information.

Safety Notice Information

The two main safety notices used in this manual are Warning and Caution. Notices in this manual will look like the example below.

Warning Notice



WARNING

ELECTRICAL HAZARD

Do not operate the mixer with the door open. Disconnect power before servicing.

A **Warning** notice tells you about a hazard that could cause serious injury to you or extensive damage to the mixer. This information is placed at the beginning of the manual to emphasize the importance of safety to your well being.

When you see a **Warning** notice in this manual, read it carefully. Before continuing with the operation of the mixer, take all necessary precautions to avoid potential injury.

Caution Notice



CAUTION

ELECTRICAL HAZARD

All electrical components must be kept dry. Never place containers of liquid on or near the control box.

A **Caution** notice tells you about a danger that could cause injury to you or minor damage to the mixer. When you see a Caution notice in this manual, read it carefully and be sure you understand it before continuing.

Safety Information

Information Notice

Note: If the cabinet vibrates, loosen the locking nuts on the right front leveling foot and slightly adjust the length.

An **Information** notice gives details that will assist you in efficiently using the mixer. When you see an Information notice in this manual, know that it is there to save you time and energy.

Compliance Information

See the affixed labeling on the machine for safety and regulatory compliance information. ETL Listed, conforms to UL STD 1450. Certified to CAN/CSA STD C22.2 No.68 (120 V model only).

Introduction

Introduction

The Harbil 5G High Speed Paint Mixer is a versatile, automatic mixer designed with concern for safety, reliability and ease of use. Its features include:

- Heavy-duty, high-capacity components and a durable finish for long wear.
- Vibration-free mixing for blending and conditioning paint.
- Versatile mixing times from 30 seconds to 3 minutes
- Handles pint, quart, gallon, and 5-gallon containers.

Important safety features are:

- Automatic shut off if the door is opened during the shaking operation.
- Fully visible red STOP switch for emergency shut off.

Product Description

Specifications

Height	45.5" (115.6 cm)
Width	28" (71.0 cm)
Depth	28" (71.0 cm)
Weight	470 lb (213.2 kg)

Contain Capacity

Maximum height	17.5" (44.5 cm.)
Minimum height	0.5" (1.3 cm)
Diameter	13.5" (34.3 cm)

Typical Electrical Supply

See name plate for specific information.

120 V \pm 10%, 60 Hz, 11.8 A

220 V \pm 10%, 50 Hz, 6.0 A

Introduction

EQUIPMENT MAINTENANCE LOG

RECORD MODEL NUMBER HERE:

RECORD SERIAL NUMBER HERE:

SERVICE DATE	DESCRIPTION & PARTS REPLACED <small>(AFTER (IN THE) (WARRANTY) (PERIOD))</small>	SERVICED BY

Unpacking Directions

Inspect the Crate for Damage

IMPORTANT



If any damage is found, notify the carrier at once and arrange for inspection in order to claim recovery. Claims for damage must be made by the consignee (You). The carrier assumes full responsibility upon acceptance of shipment and will not entertain any claims by the consignor (Fluid Management).

Unpacking and Setup

Refer to the Unpacking and Setup Instructions affixed to the shipping carton in a mailing pouch.

Electrical Connections

Electrical Connections



CAUTION

The unit must be plugged into a dedicated electrical line with no other equipment using the same circuit. **DO NOT** use an adapter or extension cord with this product.



WARNING

Improper use of the grounding plug can result in a risk of electric shock.

Grounding

This product must be grounded. In the event of an electrical short circuit, grounding reduces the risk of electrical shock by providing an escape for the electric current. This product is equipped with a cord that has a grounding wire and an appropriate grounding plug. The plug must be inserted into an outlet that is properly installed and grounded in accordance with all local codes and ordinances.



WARNING

Check with a qualified electrician or service person if grounding instructions are not completely understood or if in doubt as to whether product is properly grounded.

Danger

Improper installation of the grounding plug can result in a risk of electric shock. If repair or replacement of the cord or plug is necessary, do not connect the grounding wire to either flat blade terminal. The insulation wire with green or green and yellow stripes on the outer surface is the grounding wire. Check with a qualified electrician if the grounding instructions are not completely understood, or if in doubt about whether the product is properly grounded. **DO NOT** modify the plug provided. If it will not fit into the outlet, have the proper outlet installed by a qualified electrician.

Aligning and Leveling Mixer

Aligning and Leveling Mixer

Aligning the Struts

1. Make sure that the power is removed from the mixer.
2. Remove the top cover of the unit. Save the screws.
3. Check the inner frame and struts by grasping the frame at the top.

Vigorously rock the frame back and forth to see that all struts move freely on their supports. No kinking in the springs should occur at the bottom of the struts. The shake frame will return to the center position and appear level when it comes to rest.

4. If one or more of the struts is not seated properly, it (they) can be realigned as follows:
 - Remove the upper rear cabinet (sheet metal covering). See Figure 5, “Removing the Mixer Covers” on page 27.
 - Raise the inner frame closest to the unseated strut. The frame should be high enough for the strut pin to clear the strut body.
 - Carefully lower the frame while guiding the pin into the strut body. Take care not to raise the frame so high that the other struts become unseated.
 - Repeat this procedure for each misaligned strut.
5. Move the mixer to its permanent, leveled area. Leave ample room around the paint mixer to facilitate maintenance and safe operation.

Leveling

Although the mixer is leveled by the manufacturer, variations in floor surfaces may necessitate further adjustment.



Improper leveling may cause severe damage to the paint mixer when in mixing operation.

1. Level the mixer by adjusting the 4 feet as necessary.
2. Lock the feet into place by tightening the lock nut to the frame insert.

Aligning and Leveling Mixer

Remove Shipping Inserts

After you have plugged the mixer into a dedicated power line and leveled it, inspect to be sure that you have removed the shipping materials inside the mixer.

1. Make sure the front door of the paint mixer is closed. **A safety switch prevents the operation of the paint mixer while the door is open.**
2. Apply power to the paint mixer by placing the POWER switch in the ON position.
3. Turn the button labeled EMERGENCY STOP clockwise until the button pops out to the ON position. **If the button does not turn, then it is already in the ON position. To stop or turn off the paint mixer, push the button to the OFF position.**
4. Push the UP button. Wait several seconds until the top plate raises high enough for you to remove the shipping inserts.
5. Open the front door of the paint mixer. Remove the shipping inserts and the wooden disc insert. **If there is not enough room to remove the inserts, then push the UP button again.**
6. Be sure that you save the plywood and the foam rubber discs. These will be used with 5-gallon pails.
7. Before performing an operational test, read the following information ***Getting To Know Your Mixer.***



Getting to Know Your Paint Mixer

Getting to Know Your Paint Mixer

General Locations

- CONTROL PANEL – All controls are in one location.
- DOOR SAFETY SWITCH – The Door must be closed continuously to operate the paint mixer.
- WARNING STICKERS – Read these important messages for YOUR safety.
- ADJUSTABLE FEET – The leveling feet adjust in order to level the mixer.

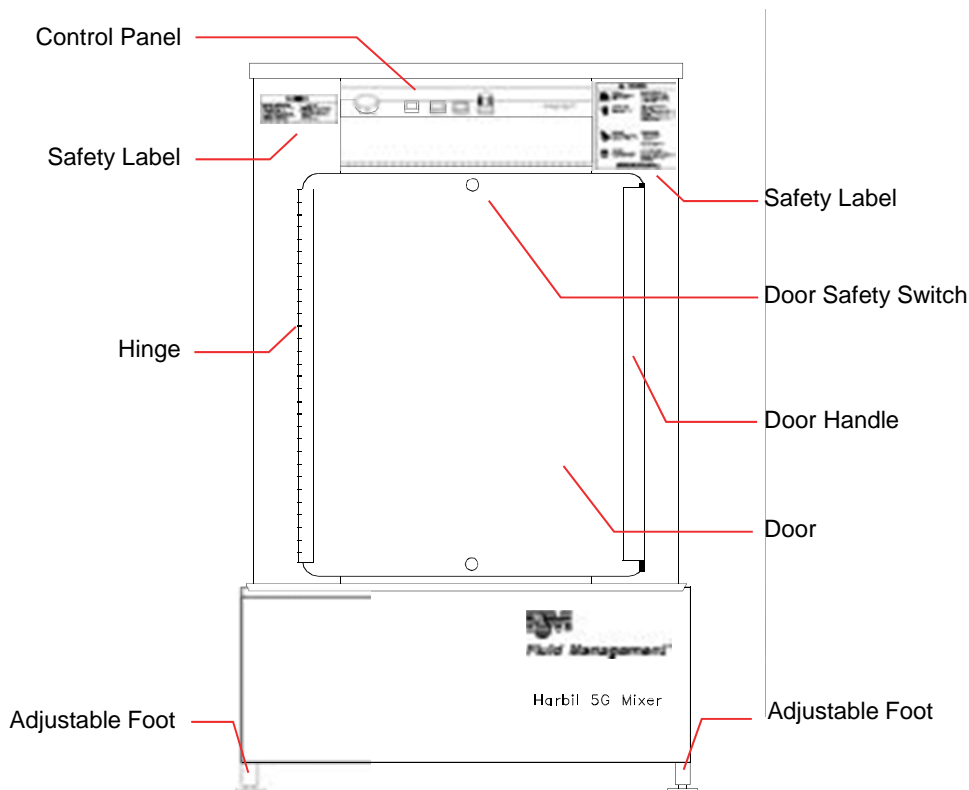

Figure 1. General Locations

Getting to Know Your Paint Mixer

Control Panel

- EMERGENCY STOP button for quickly stopping the mixer.
- POWER rocker switch for applying power to the machine.
- UP button for raising the top pressure plate.
- START button for activating the mixer.
- TIMER for setting the desired mix time from 30 seconds to 3 minutes.



Note

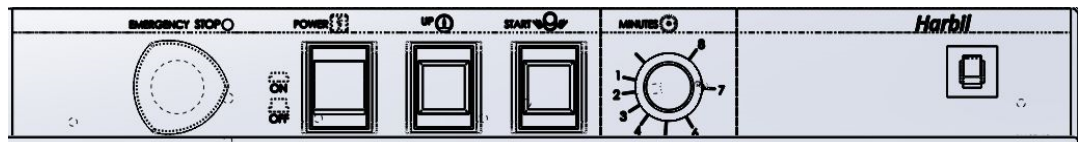

Figure 2. Control Panel

Reversible Door

The door on the mixer can be easily reversed using a slotted screwdriver. Instructions for reversing the door are found in the maintenance section of this documentation.

Getting to Know Your Paint Mixer

14 | Harbil 5G Mixer



Fluid Management Customer Service 1.800.462.2466

Important Information

Before operating the mixer, carefully read the following important information.

Important Information

Warnings

- Verify that your paint mixer is properly levelled. Improper leveling may cause severe damage to the machine during the mixing operation.
- Always shut off the master POWER switch and unplug the mixer from the AC power outlet before servicing the paint mixer.
- THIS MACHINE IS NOT EXPLOSION-PROOF AND MUST NOT BE USED IN A FLAMMABLE ATMOSPHERE.

Cautions

- Do not run the paint mixer without a container in place.
- Do not mix more than one full case (four 1-gallon cans) of paint at one time. The maximum weight limit is 80 pounds for paint and 60 pounds for stucco mixture. See BASIC OPERATION, Figure 3, "Gallon Can Placement" on page 16.
- On 5-gallon metal containers, use the flake-board disc for recessed bottoms that do not have a center support. Use the discs for recessed tops. See BASIC OPERATION, Figure 4, "5-Gallon Container Cut-Away View" on page 17.
- On 5-gallon plastic containers, use the foam discs for the recessed tops around the bung hole. **Do not use the flake board disc on plastic containers.**

Basic Operation

Basic Operation

Open the door. If you need to raise the top plate to accommodate the container to be mixed, turn on the POWER switch and push the UP button. Wait a few seconds until the UP light goes out. This will raise the top plate about two inches. Repeat if necessary.



To quickly stop the machine, push the EMERGENCY STOP button. If you open the door during the operation, the paint mixer will stop.

Note

1. After opening the front door, place the container(s) near the center of the table. The diagram below illustrates the proper gallon can placement.

Cans must be removed from cardboard case before mixing.

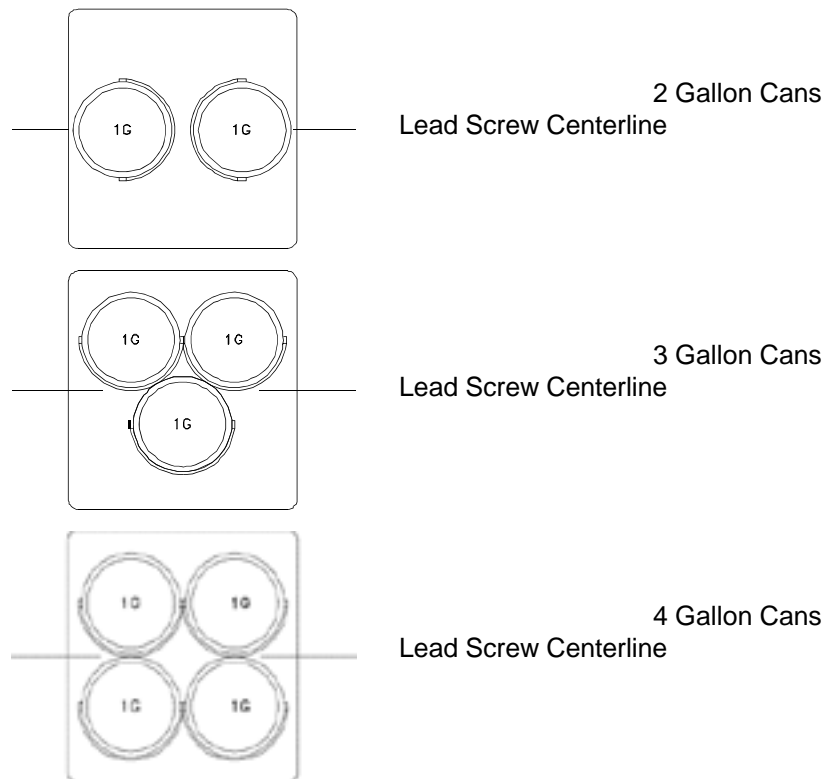

Figure 3. Gallon Can Placement

Basic Operation

- When using 5-gallon plastic or metal containers with recessed lids, place the foam disc on top of the container even with the rim.

Note: Both thick and thin discs come with the mixers. Foam discs eliminate flexing of the container. On metal containers with recessed bottoms and no center support, place the flake board disc underneath the container.

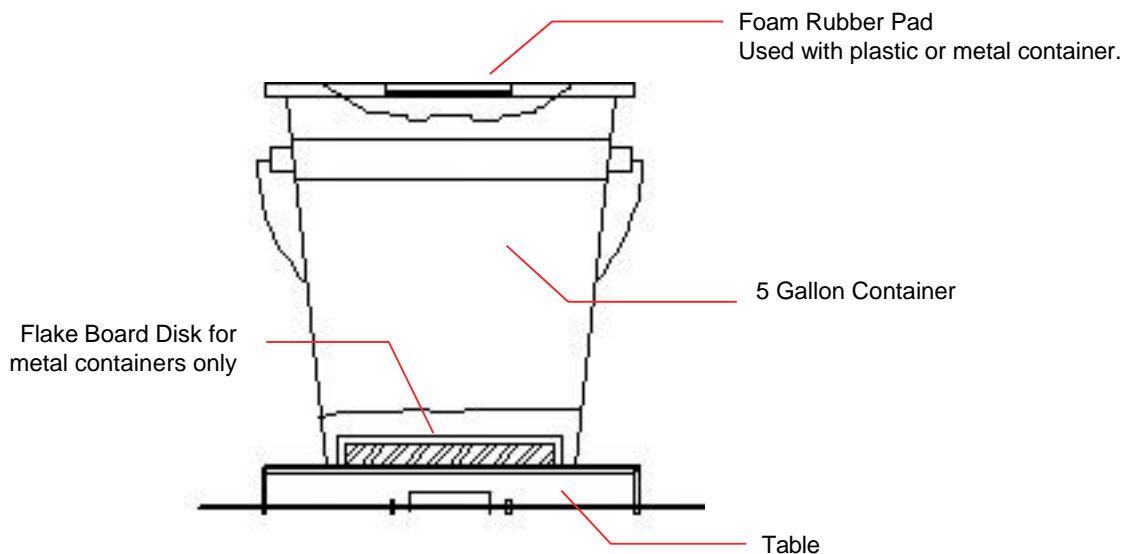

Figure 4. 5-Gallon Container Cut-Away View

- Close the door firmly. **The paint mixer will not operate with the door open.**
- Set the timer on the control panel to the desired shaking time.
- Apply power to the mixer by pressing the POWER rocker switch to the ON position and turning the EMERGENCY STOP button clockwise until it pops out to the ON position. If the button does not turn, then it is already in the ON position. **To stop the paint mixer, depress the EMERGENCY STOP button.**

Basic Operation

6. Push the START button. The paint mixer will go through the following sequence:
 - The paint mixer will automatically move the top plate down and hold the container in place.
 - The paint mixer will shake the container for the set amount of time.
 - The paint mixer will raise the top plate about 2 inches. Allow a few seconds for the top plate to raise.
7. Remove the paint container when the mixer is completely stopped.

Operational Test

Operational Test

Operational Test Procedure

1. Plug in the mixer.
2. Using two one-gallon containers followed by a five-gallon container, perform these steps:
 - With the one-gallon containers in position on the table, set the TIMER to its minimum value.
 - Twist the EMERGENCY STOP to release it.
 - Depress the POWER switch.
 - With one hand on the EMERGENCY STOP, depress the START switch. The unit should cycle automatically—clamping down and starting the shake cycle with a smooth, vibration-free movement.
3. If vibrations are noticed, immediately press down the EMERGENCY STOP switch.
 - *Mild vibrations* may occur because the unit is not properly leveled. Try slipping a piece of paper under each of the four (4) adjustable feet. If the paper easily slides under a foot (feet), then the mixer is not solidly contacting the floor. Level as necessary.
 - *Severe or persistent vibrations* may be caused by a variety of problems. Check to make sure that the struts are moving freely. If they are, then contact a qualified service technician or Customer Service at Fluid Management for assistance before continuing to operate the mixer.
4. Repeat the above steps using a 5-gallon container.
5. When the unit is operating smoothly, replace and secure the top cover and upper rear cabinet with the screws.
6. Your high speed paint mixer is now ready for operation. Please read the next two sections to familiarize yourself with the machine and how to operate it safely.

Maintenance Procedures

Maintenance Procedures

General Lubrication

To ensure safe, dependable operation of the paint mixer, follow the maintenance schedule detailed below.

WEEKLY

Lubricate the following items with SAE 20 oil:

- Top pressure plate nut (accessed through the right and left side doors)
- Threaded lead screw (accessed through the front door)

EVERY 3 MONTHS

Lubricate the Super-Struts with SAE 20 oil:

- Apply oil to the Super-Strut pins so that the oil will flow down the bushing.
- Lubricate the struts on the both sides of the mixer.

EVERY 6 MONTHS

Grease flange bearings.



Troubleshooting

Troubleshooting

Using the chart below, locate the problem in the first column, then select the probable cause to check and action to take from the next two columns. The problems are arranged from the simplest to the most complex.

Where appropriate, refer to the Servicing and Repair section to correct the problem.

PROBLEM	CHECK	ACTION
The paint mixer does not start.	<ul style="list-style-type: none"> ✓ if mixer attached to receptacle. ✓ receptacle for voltage. ✓ if front door is not closed. ✓ POWER switch is in the ON position and operating properly. The EMERGENCY STOP button should not be depressed. ✓ 6.3 amp fuse. ✓ 5 amp Slow-Blow fuse. ✓ PCB connector. ✓ may be a problem with printed circuit board. 	<ul style="list-style-type: none"> • Connect to power source. • Contact electrician. • Close the front door. • Turn on POWER switch. Put the EMERGENCY STOP button in the ON position. • Replace fuse. • Replace fuse. • Reestablish PCB connector. • Call Customer Service. • Replace printed circuit board.
The top plate does not move in a downward direction.	<ul style="list-style-type: none"> ✓ loose/broken wire in the DC motor cable. ✓ START switch mechanism on the control panel for a loose connection. ✓ DC motor. ✓ may be a problem with printed circuit board. 	<ul style="list-style-type: none"> • Reconnect loose wire or replace broken wire. • Tighten connections at the START switch. • Replace START switch mechanism. • Using voltmeter, measure voltage at DC motor or call Customer Service. • Replace DC motor. • Call Customer Service. • Replace printed circuit board.



Troubleshooting

PROBLEM	CHECK	ACTION
The top plate does not move in an upward direction.	<ul style="list-style-type: none"> ✓ voltage at the DC motor. ✓ broken wire in the DC motor cabling. ✓ problem with the DC motor. ✓ problem with the UP switch mechanism on the control panel. ✓ may be a problem with printed circuit board. 	<ul style="list-style-type: none"> • Use voltage meter or contact Customer Service for assistance. • Replace broken DC motor cabling. • Contact Customer Service. • Replace DC motor. • See wiring schematic and test with voltmeter. • Replace the UP switch mechanism. • Call Customer Service. • Replace printed circuit board.
Paint mixer runs before the top plate clamps on the container.	<ul style="list-style-type: none"> ✓ binding of the top plate. ✓ may be a problem with printed circuit board. 	<ul style="list-style-type: none"> • Clean and oil lead screws. • Call Customer Service. • Replace printed circuit board.
Paint mixer will not shut off.	<ul style="list-style-type: none"> ✓ timer control on the front control panel. ✓ if relay is stuck in the closed position. ✓ bad timer. ✓ may be a problem with printed circuit board. 	<ul style="list-style-type: none"> • Replace if necessary. • Replace relay. • Replace timer. • Call Customer Service. • Replace printed circuit board.
The shake motor has voltage and hums, but it will not run.	<ul style="list-style-type: none"> ✓ low line voltage. ✓ V-belt tension. ✓ motor capacitor. ✓ shake motor. 	<ul style="list-style-type: none"> • Confirm that the mixer is on a dedicated line. • Correct tension. • Replace motor capacitor. • Replace shake motor.

Troubleshooting

PROBLEM	CHECK	ACTION
An excessive amount of vibration occurs.	<ul style="list-style-type: none"> ✓ mixer is out of balance. ✓ adjustable leg is broken or damaged. ✓ broken strut. 	<ul style="list-style-type: none"> • Level by adjusting the legs. • Replace adjustable leg. • Replace broken strut.
START light is on and nothing happens.	<ul style="list-style-type: none"> ✓ DC motor coupling set screw is loose. ✓ broken wire in the DC motor cabling. ✓ problem with the DC motor. ✓ may be a problem with printed circuit board. 	<ul style="list-style-type: none"> • Tighten the DC motor coupling set screw. • Replace DC motor cable. • Replace DC motor. • Call Customer Service. • Replace printed circuit board.
START light is on and the top plate clamps on the container, but mixer will not run.	<ul style="list-style-type: none"> ✓ make sure that the mixer is on a dedicated line. ✓ if front door closed. ✓ problem is a loose motor coupling set screw. ✓ reset button. ✓ loose or broken wire in the shake motor cabling. ✓ shake motor. 	<ul style="list-style-type: none"> • Connect to dedicated line. • Close the door. • Tighten DC motor coupling set screw. • Press blue reset button located on overload relay. • Tighten or replace wire. • Replace shake motor cabling if necessary. • Replace wire. • Contact Customer Service for assistance. • Replace the shake motor.
The mixer starts slowly and then increases to normal speed in a few seconds.	<ul style="list-style-type: none"> ✓ shake motor V-belt tension. 	<ul style="list-style-type: none"> • Adjust the shake motor V-belt tension.

Troubleshooting

PROBLEM	CHECK	ACTION
The DC motor runs, but the top plate does not move.	<ul style="list-style-type: none"> ✓ for loose set screw in one of the DC motor couplings. ✓ key and set screw on timing gears. 	<ul style="list-style-type: none"> • Tighten set screw(s). • Tighten key and set screw.
The mixer stops before completing shake cycle.	<ul style="list-style-type: none"> ✓ for broken or loose wire in the DC motor cabling. 	<ul style="list-style-type: none"> • Replace DC motor cable.
The mixer speeds up and slows down. The START light is blinking.	<ul style="list-style-type: none"> ✓ if front door is making contact with the safety switch in the control box. ✓ broken wire in DC motor cabling. 	<ul style="list-style-type: none"> • Adjust safety switch. • Replace DC motor cable.
The mixer crushes or throws cans.	<ul style="list-style-type: none"> ✓ clamping force may be out of adjustment. 	<ul style="list-style-type: none"> • Adjust clamping force as required

Servicing and Repair

Servicing and Repair

General Information

If you do not feel confident about disassembling the paint mixer or replacing a part, **DO NOT ATTEMPT THE PROCEDURE**. Should problems or questions arise, contact Customer Service at Fluid Management.

Carefully read all of the instructions before you begin. For component identification and location, refer to the Parts Section of this manual.

Safety Procedure



WARNING

ELECTRICAL HAZARD

Always shut off the POWER switch and unplug the mixer before servicing.



WARNING

Wear your safety glasses to prevent possible injury.

Opening the Mixer

Remove Exterior Panels

Opening the Mixer

1. Using a medium-size screwdriver or 1/4" nut driver, remove the sheet metal screws securing the top cover. Lift it off the mixer.

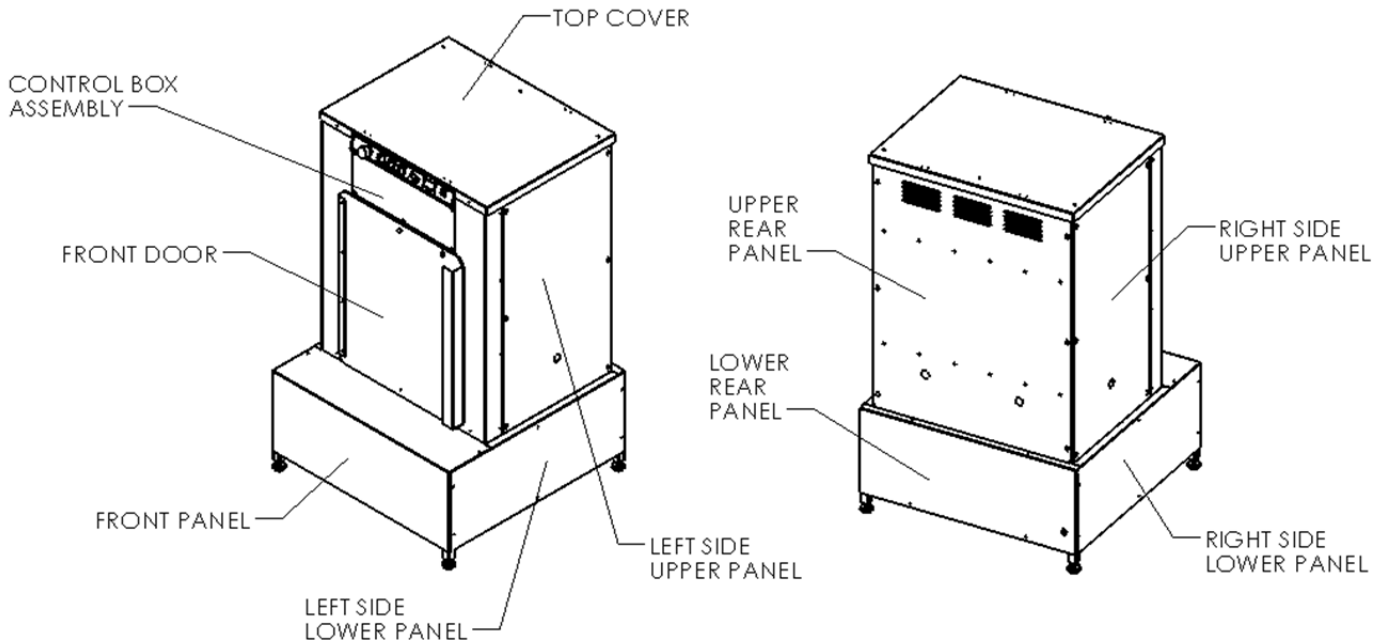

Figure 5. Removing the Mixer Covers

2. In the same manner, take off the upper rear panel and left and right upper side panels covering the sides and back, and set to the side of the work area.
3. If your machine has a 4-sided skirt, remove it now.
4. At the back of the mixer, squeeze the power supply strain relief with a pair of pliers, and pull it off the cord. Move the back panel away from the machine (the cord will still be attached).
5. Remove the right and left side panels, and the lower front panel.
6. To prevent damage, remove the mixer door by lifting the door off its pins.
7. Cut the upper wire tie wrap securing the 3 cables to the outer frame at the left side of the machine.
8. Remove the remaining front sheet metal covering. Carefully prop the front piece (two front columns with control box assembly) to the side of the machine, being careful to not damage the cords.

Removing Shake Frame

Removing Shake Frame

Some service procedures involve removing the shake frame. Read all of the following instructions. If you have any doubt about performing these procedures, please contact Customer Service at Fluid Management. For component identification and location, refer to the Parts Section of this manual.

Removing Shake Frame Procedure

1. Remove the sheet metal covers (see OPENING THE MIXER, page 27).
2. To facilitate the reassembly process, mark or prepare a drawing of the 2 wires running from the left side of the terminal block to the control box.
3. Using a small blade screwdriver, disconnect the 2 wires.
4. Pull the cable containing the 2 wires through 2 tie wraps, or snip and remove the tie wraps with side cutters.

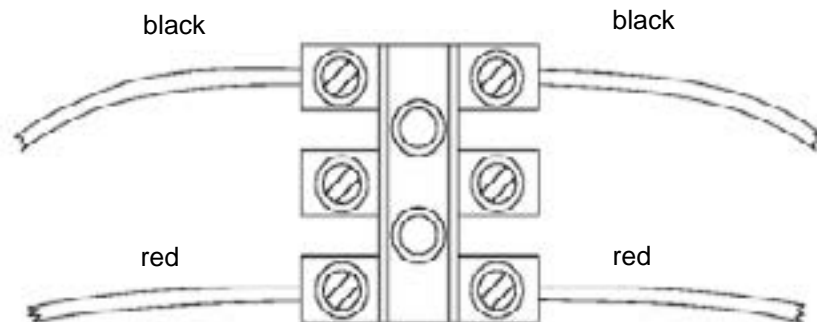

Figure 6. Disconnecting the 4 Wires at the Terminal Block

Removing Shake Frame

5. Follow the cable to the strain relief, located on the inside of the hole where the cable goes through the shake frame. Unscrew the strain relief and pull the cable through the hole into the enclosure.

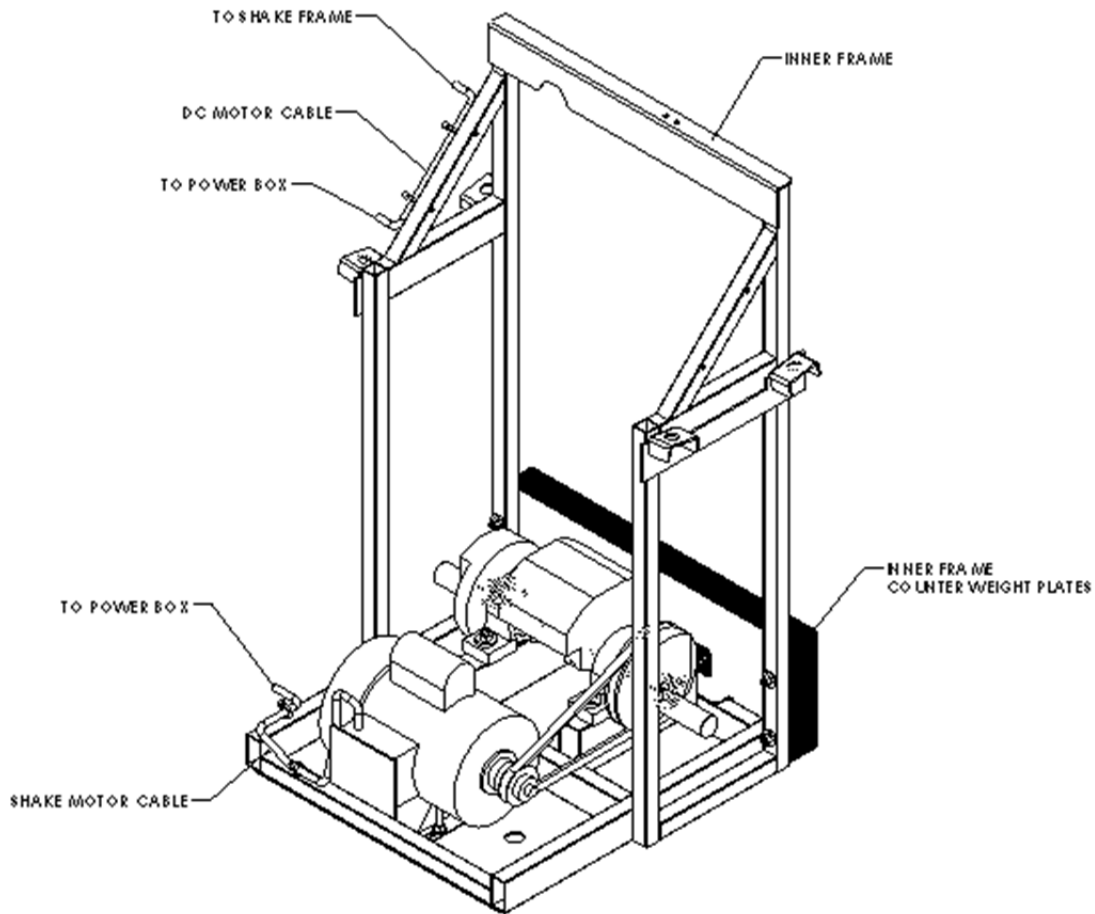

Figure 7. Removing the Shake Frame

Removing Shake Frame

Remove the Counterweights

Remove the Counterweights Procedure

1. Remove the 16 lower inner frame counterweight plates to access the nuts on the flange bearings and the rear screws and nuts on the pillow block bearings.

Note: Use two 1/2" wrenches, or a ratchet and a 1/2" wrench to remove the 4 lower nuts and screws holding the lower plates to the inner frame to allow access to the crankshaft.

2. With two 3/4" wrenches or a ratchet and a 3/4" wrench, loosen BUT DO NOT REMOVE the 4 screws securing the flange bearings to the shake frame. Remove the 4 nuts.

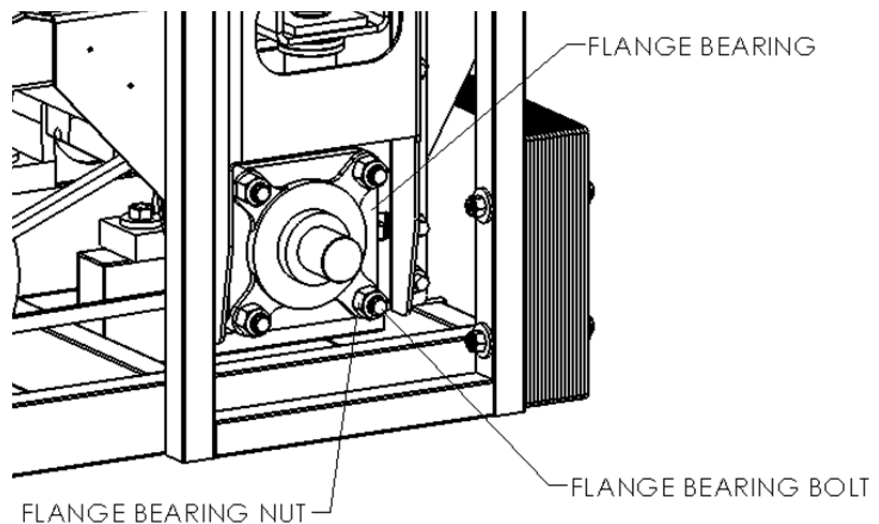

Figure 8. Flange Bearings

Removing Shake Frame

3. With a 1/8" hex wrench, loosen the 2 set screws holding the crankshaft to the flange bearings. Remove the flange bearings. If necessary, use a wheel puller to pry the flange bearing from the crankshaft.



Be careful when removing the shake frame. It may swivel or fall forward while working on the next step.

CAUTION



Be careful when lifting. The shake frame weighs over 200 pounds.

CAUTION

4. Repeat steps 2 – 3 on the other side

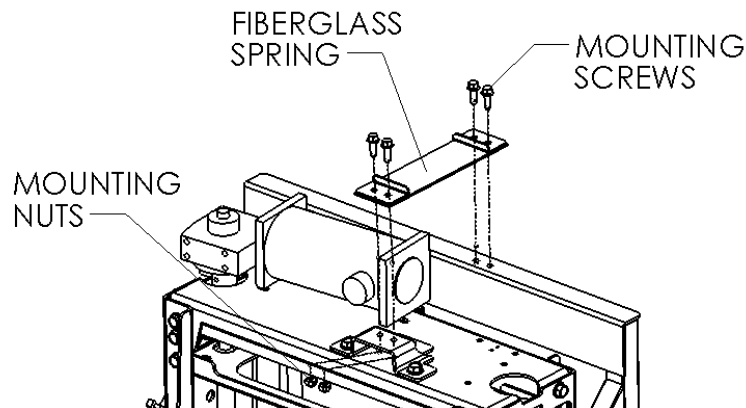

Figure 9. Nuts and Screws Holding Swivel Rods

5. Position one person at the back of the mixer to hold the shake frame. Using a 3/8" socket and 7/16" open-end wrench, remove the 2 nuts and screws holding the fiberglass spring to the inner frame.
6. With the assistance of another person, lift up and pull out the complete shake frame.

Testing Shake Motor

Testing Shake Motor

Read all of the following instructions. If you have any doubt about performing these procedures, please contact Fluid Management.

For component location and identification, refer to the Parts Section of this manual.



WARNING

ELECTRICAL HAZARD

To carry out this test you will need 120 volts which could cause electrical shock.

Testing Shake Motor Procedure

1. Place an empty pail on the table and close the door firmly. Turn on the paint mixer and push the START button. Give the paint mixer enough time to lower the top plate onto the pail.
2. Turn off the paint mixer and unplug the electrical cord.
3. Remove the lower front and right side panels.
4. Remove the motor cover.
5. Take a 3-conductor jumper cable, which has a plug at one end and stripped wires on the other end, and connect the wires to the shake motor.
6. Plug the jumper cord into a wall outlet (120 volts or appropriate voltage).
 - If the shake motor starts to run, then the cable or the relay is bad.
 - If the shake motor does not run, it has to be replaced.
7. Unplug and remove the jumper cord from the shake motor.
8. Reassemble the mixer by returning the motor cover and lower panel to their correct positions.

Changing Shake Motor

Read all of the following instructions. If you have any doubt about performing these procedures, please contact Customer Service at Fluid Management.

Turn to the Parts Section of this manual for component identification and location.

Changing Shake Motor

Changing Shake Motor Procedure

1. Unplug the electrical cord.
2. Remove lower front and right/left side panels.
3. Make a drawing of the wire to the terminal connections, then disconnect the wires from the shake motor.
4. Remove the 4 hold-down screws on the motor.
5. Remove the V-belt from the pulley on the motor.
6. Remove and replace the motor.
7. Remove the pulley from the old motor by loosening the set screw.
8. Reposition the wires on the new shake motor by following the drawing made in Step 3.
9. Reinstall the pulley on the new motor.
10. Put the V-belt on the balance groove pulley, then on the motor pulley.
11. Align the motor pulley with the groove pulley on the crankshaft.
12. Install and tighten down the 4 motor hold-down screws while keeping tension on the belt.
13. **Be sure to adjust the shake motor for proper tension on the V-belt. The deflection should be approximately 3/16" at 5 pounds of pressure.**
14. Reassemble the paint mixer by reversing these instructions.
15. With a paint container in position, perform a test run of the mixer to be sure that it is operating correctly.

Changing the V-Belt

Changing the V-Belt

Read all of the following instructions. If you have any doubt about performing these procedures, please contact Customer Service at Fluid Management.

Refer to the Parts Section for component identification and location.

Changing the V-Belt Procedure

1. Unplug the electrical cord.
2. Remove all the sheet metal covers (see OPENING THE MIXER, page 27).
3. Loosen the screws and nuts on the flange bearings.
4. Slide the shake frame away from the right side of the crankshaft.
5. Remove the flange bearing on the right side of the machine.
6. Loosen the shake motor mounting screws and slide the motor toward the crankshaft, thereby loosening the V-belt. Remove the V-belt.
7. Put the new V-belt on the balance groove pulley, then on the motor pulley.
8. Install and tighten down the 4 motor hold-down screws while keeping tension on the belt.
9. Be sure to adjust the shake motor for proper tension on the V-belt. The deflection should be approximately 3/16" at 5 pounds of pressure.
10. Reassemble the paint mixer by reversing these instructions.

Removing Circuit Board

Read all of the following instructions. If you have any doubt about performing these procedures, please contact Customer Service at Fluid Management.

Turn to the Parts Section for component identification and location.

Removing Circuit Board



WARNING

ELECTRICAL HAZARD

The mixer must be unplugged before attempting this procedure. There is a chance of electrical shock.

Removing Circuit Board Procedure

1. Unplug the electrical cord.
2. Remove the sheet metal screws on the control panel and slowly swing it down.
3. Remove the push-on type connector at the bottom of the printed circuit board.

Pull the connector with alternating left and right force away from the circuit board. It is not necessary to loosen the screws on the connector.

4. Remove the 4 nuts from the screws that attach the circuit board to the control panel.
5. Install the new board with the push-on connector.
6. Reinstall the control panel and the top cover.
7. Connect the electrical cord.

Installing Rubber Pads

Installing Rubber Pads

Read all of the following instructions. If you have any doubt about performing these procedures, please contact Customer Service at Fluid Management.

For component identification and location, consult the Parts Section of this manual.

A special rubber pad is fastened to the top plate to hold cans in place during operation. **When attaching the rubber pad to the upper plate, use P/N 4000327, Loctite Super Bonder #416 Instant Adhesive.** Follow the instructions on the adhesive for the drying time. Use protective gloves when applying the adhesive.

Installing Rubber Pads Procedure

1. Apply a non-flammable solvent to remove the old adhesive.
2. Apply the permanent adhesive to the pad. Follow the glue pattern shown in the diagram.

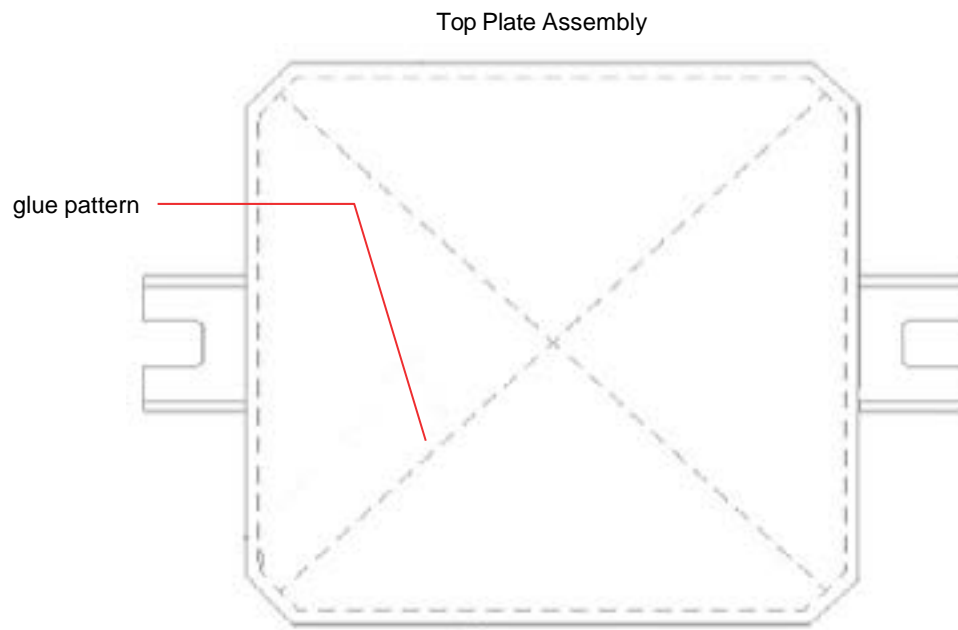

Figure 10. Glue Pattern

Installing Rubber Pads

3. Making sure the pad is positioned properly, attach the pad to the plate and hold in position for about 2 minutes.
4. Remove the backing from the tape on the replacement lower table and press into position.
5. After attaching the pads, place four 1-gallon cans on the table.
6. Turn on the mixer. Allow the top plate to lower onto the cans and Turn off the mixer before it goes into the shaking cycle.

This step is only to press the pads in place during drying of the glue.

DO NOT ALLOW THE MIXER TO SHAKE THE CANS OF PAINT.

7. Unplug the electrical cord as a safety precaution.
8. Allow the adhesive to dry overnight.
9. After the adhesive has dried, open the mixer, remove the cans and test as appropriate.

At this point, the mixer should be ready for normal operation.

Replacing / Adjusting DC Motor

Replacing / Adjusting DC Motor

The DC motor needs adjusting if it is making excessive noise while the top plate is moving. Adjustments are also required when reinstalling or replacing the motor.

Read all of the following instructions. If you have any doubt about performing these procedures, please contact Customer Service at Fluid Management.

DC Clamping Motor Replacement/Adjustment

1. Make sure that the power is off.
2. Remove the top cover.
3. If you only need to readjust the DC motor, execute the following steps:
 - Loosen the 4 mounting screws that connect the DC motor to the frame.
 - Assure that the DC motor is properly aligned and fully tighten the 4 mounting screws.If you need to replace the motor, go to the next step.
4. Disconnect the red and black motor leads from the terminal block.
5. Remove the 4 screws that connect the DC motor to the shake frame.
6. Loosen the Allen set screw and remove the coupling half from the old motor and save for later use.
7. Place the coupling half onto the new motor and tighten the set screw.
8. Place the new DC motor in the shake frame while easing the coupling over the lead screw. **DO NOT STRESS THE COUPLING.**
9. Insert and tighten the 4 mounting screws.
10. Mount the DC motor coupling onto the lead screw by tightening the set screw.
11. Connect the red and black motor leads to the terminal block.
12. Replace the top cover.
13. Connect power to the mixer.
14. Execute the operational test.

Adjusting Clamping Force

Clamping Force Adjustment

The clamping force needs adjusting if cans are being crushed or thrown from the shake frame. Adjustments may also be required after changing the control board or other components in the shake mechanism. The clamping force is specified in the instructions (P/N 24040) that come with the replacement board. The adjustment kit (P/N 24041) also comes with the same instructions.

Read all of the following instructions. If you have any doubt about performing these procedures, please contact Customer Service at Fluid Management.

Refer to the Parts Section for component identification and location.

The optimum clamping force is specified in the instructions (P/N 24040) shipped with the board. This process should be used to adjust the clamping force to a range within that target. The range is expressed in terms of an “upper limit” and a “lower” limit. Both the positioning spacer (P/N 24069) and the gauge (P/N 24124) are required in executing this process.

Clamping Force Adjustment Procedure

1. Unplug the power cord from the electrical outlet.
2. Remove the 2 screws at the top of the control box and open, exposing the control circuit board.

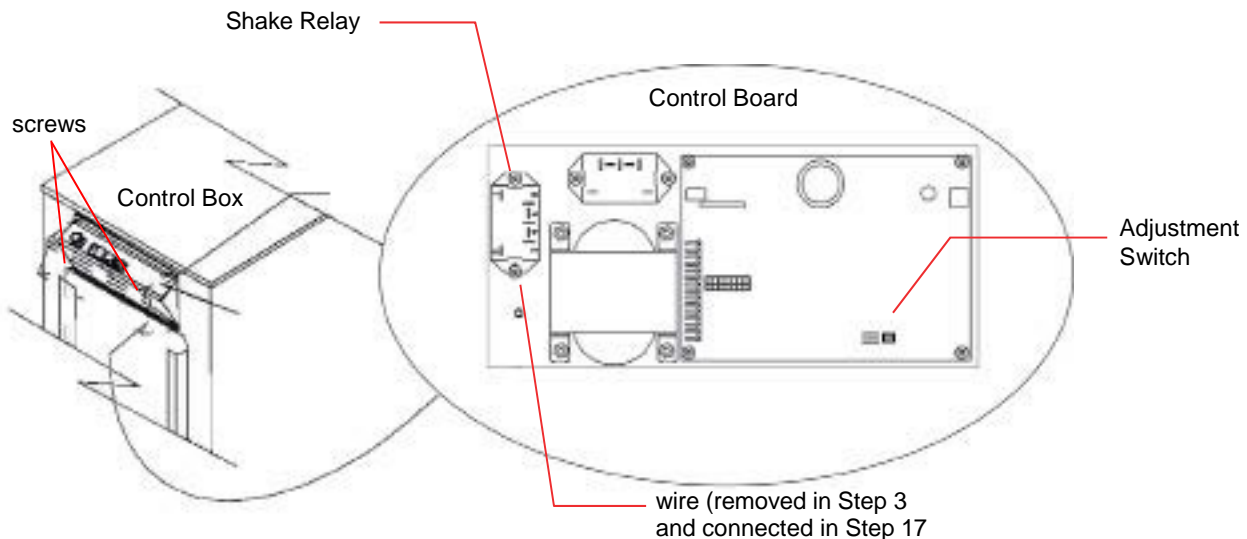

Figure 11. Control Board Location

Adjusting Clamping Force

3. Remove the wire from the upper left terminal of the shake relay.
4. On the control board, set the adjustment switch to position number 2.
5. Plug the power cord back into the electrical outlet.
6. Assure that the E-Stop button is released and press the power ON switch.
7. Press the UP button on the control box.
8. Open the door and place the positioning spacer (P/N 24096) and gauge (P/N 24124) on the bottom plate against the back lip as shown.

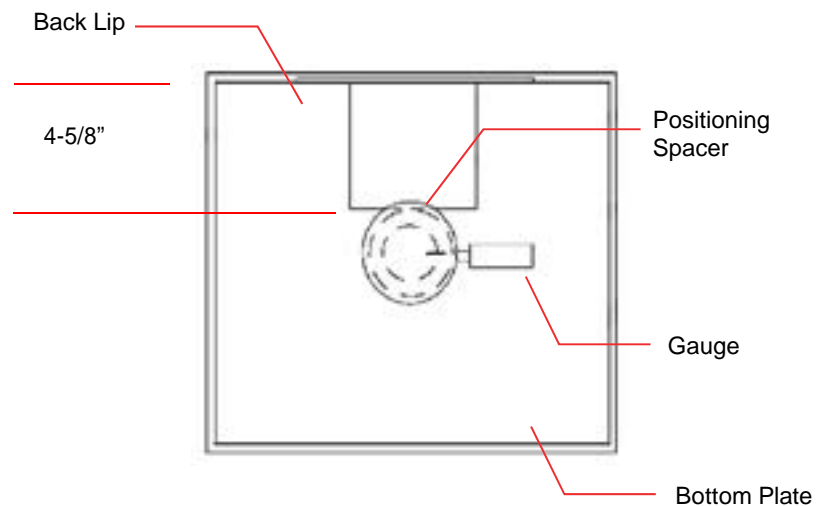

Figure 12. Gauge Position

Note: Position is critical. Use the positioning spacer. Be sure the gauge is centered and 4-5/8" from the back lip.

9. Press the START button. The top plate will clamp the gauge without going into the shaking cycle.



If wire was not removed in step #3, the mixer will shake, possibly causing damage or injury.

Adjusting Clamping Force

10. After clamping, read and record the force on the gauge.
11. Place the power switch in the OFF position, wait about 5 seconds and return it to the ON position.
12. Press the UP button.
13. If the force is at the lower limit or less, change the adjustment switch to the next lowest number and go to step #9.

Note: If the force is at the “upper limit” or greater, change the adjustment switch to the next highest number and go to step #9. If the force falls within the target, go to the next step.
14. Press the power OFF switch.
15. Remove the gauge and spacer.
16. Unplug the power cord from the electrical outlet.
17. Place the wire back on the upper left terminal on the shake relay.
18. Close the control box and insert the screws.
19. Plug the power cord into the electrical outlet.

At this point, the mixer is ready for normal operation.

Reversing Door

Reversing Door

The front door can be reversed to accommodate any space plan. Some layouts lend themselves to a front door that opens with the handle on the left. Others require that the door open in the reverse of this. The mixer is shipped with the door handle on the right side.

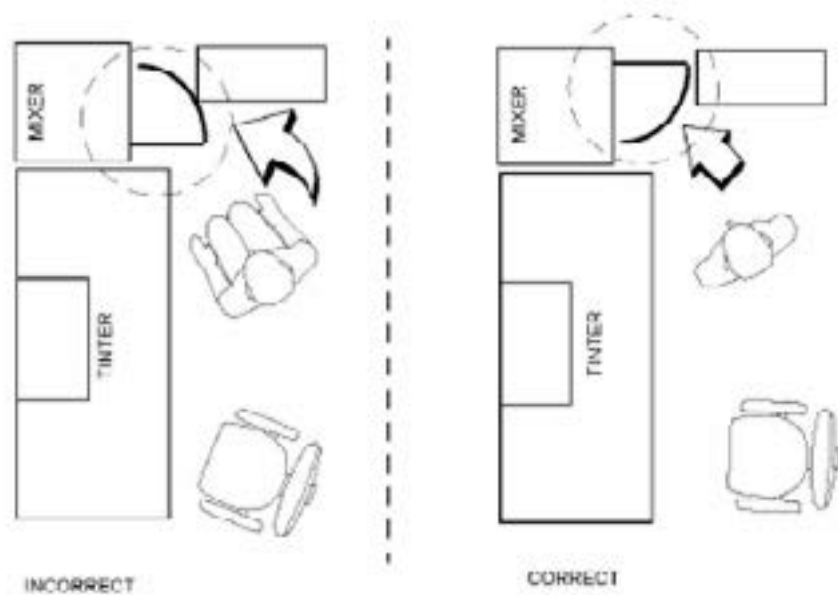

Figure 13. Floor Plans

The following steps represent the process by which the front door is reversed.

Reversing Door Procedure

1. Unplug the power cord from the electrical outlet.
2. Open the door.
3. Using two 3/8" wrenches, relocate the stud at the top of the door to the hole at the bottom of the door.

Note: If the stud is not relocated properly, the mixer will not operate.

Reversing Door

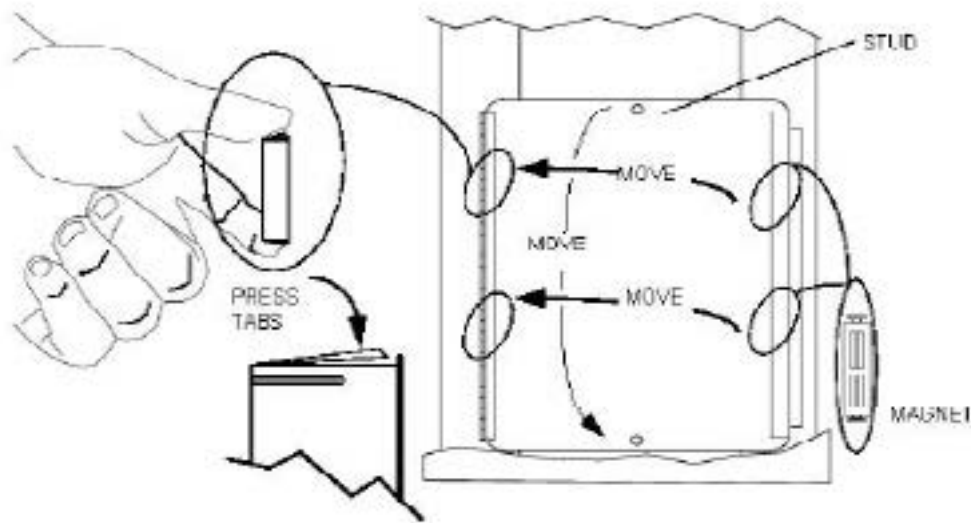

Figure 14. Reversing Door

4. Using a slotted screw driver, remove the 4 screws that mount the door to the mixer. Save for later use.
5. Reach behind the door post and remove the 2 magnets by pressing the tabs.
6. Insert these magnets in the slots on the opposite door post.
7. Position the door with the stud at the top and mount on the door post using the screws that were removed earlier.
8. Close the door.
9. It may be necessary to adjust the safety switch at the top of the door near the stud. You should hear a clicking sound as the door is opened and closed. Side- to-side adjustments are done with a slotted screw driver.

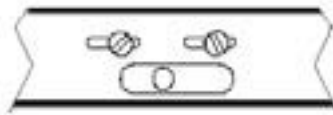

Figure 15. Safety Switch Adjustment

Replacing Super-Struts

Replacing Super-Struts

Read all the directions carefully. If you do not feel comfortable disassembling the mixer or replacing a part, do not attempt the procedure. Refer to the Parts Section for component identification and location.

Removing the External Panels

1. Unplug the electrical cord.
2. Remove the top cover and lift it off the mixer.
3. Remove the upper rear cabinet (3-sided piece), front cover, and right and left side panels (see Figure 5, "Removing the Mixer Covers" page 27).
4. Set the covers to the side of the work area.

Removing the Super-Struts

1. Locate the 4 Super-Struts to be replaced. **You will be replacing the struts on one side at a time.**

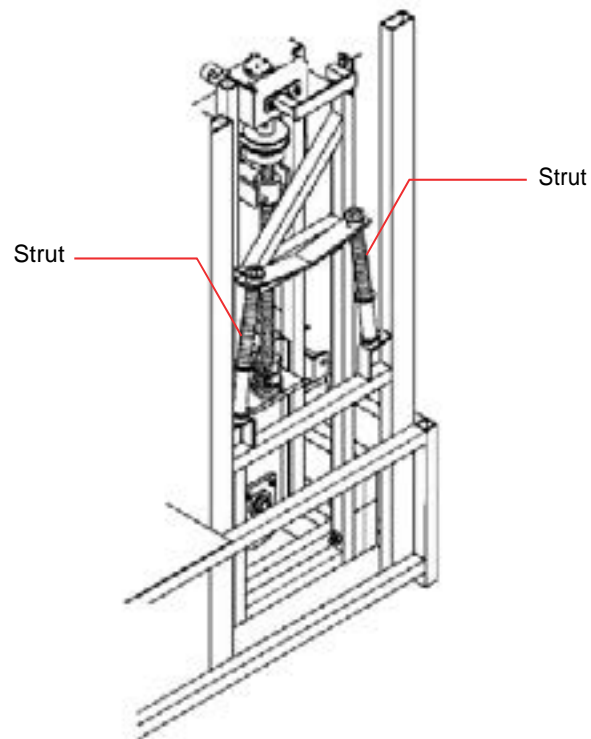

Figure 16. Locating the Struts

Replacing Super-Struts

2. Locate the hole in the strut pin. Insert the end of the 1/8" hex key into the hole to prevent the pin from rotating while loosening the bolt. If no hole is observed, grasp the pin with vice grips and loosen the nut.

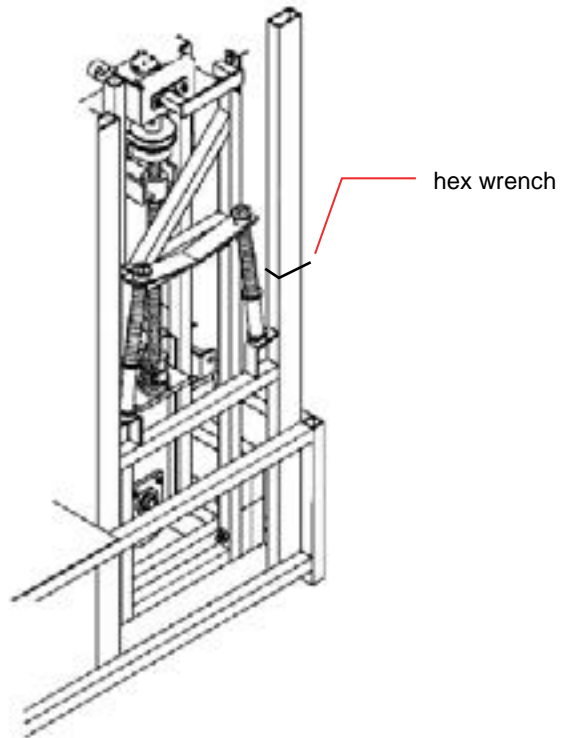

Figure 17. Keeping the Strut Pin from Rotating

3. Beginning on the right side, use a box end or adjustable wrench to remove the top nuts, washers, and rubber grommets on both struts. Remove the hex wrench from the hole in the strut pin.

Replacing Super-Struts

- Using the 2" x 4' wooden board for leverage, lift the shake frame in the center until the 2 strut pins are raised high enough to clear the strut bodies.

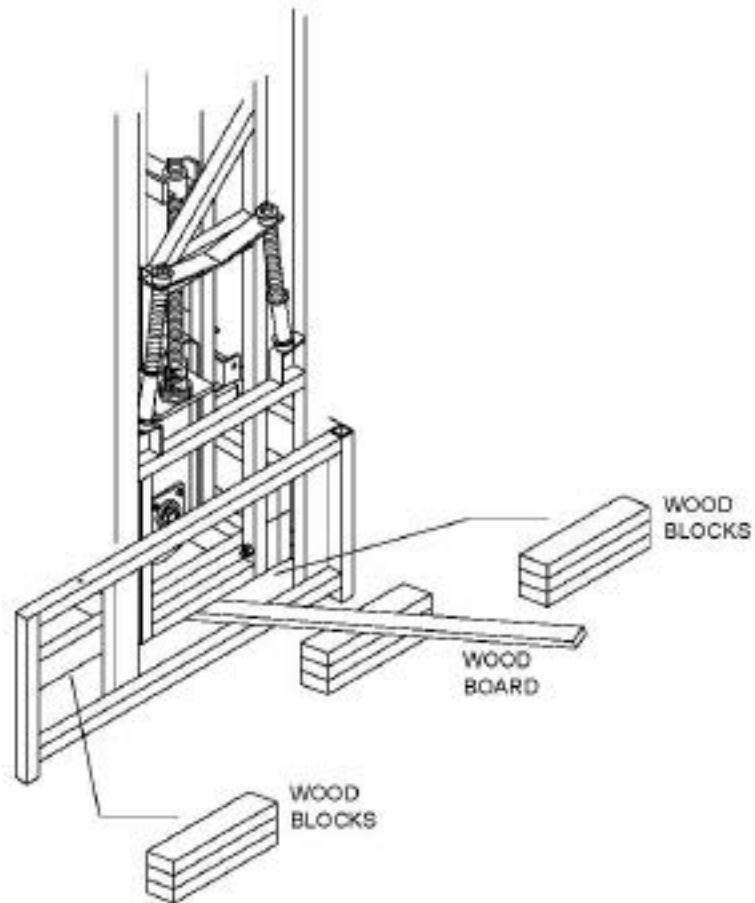

Figure 18. Lifting the Inner Frame

- Have a second person place three 2" x 4" blocks under the front and rear inner frame for support as shown below.
- Remove both strut pins, bodies, and springs from the frame.

Replacing Super-Struts

Installing the Super-Struts

Refer to the Super-Strut assembly drawing for parts locations.

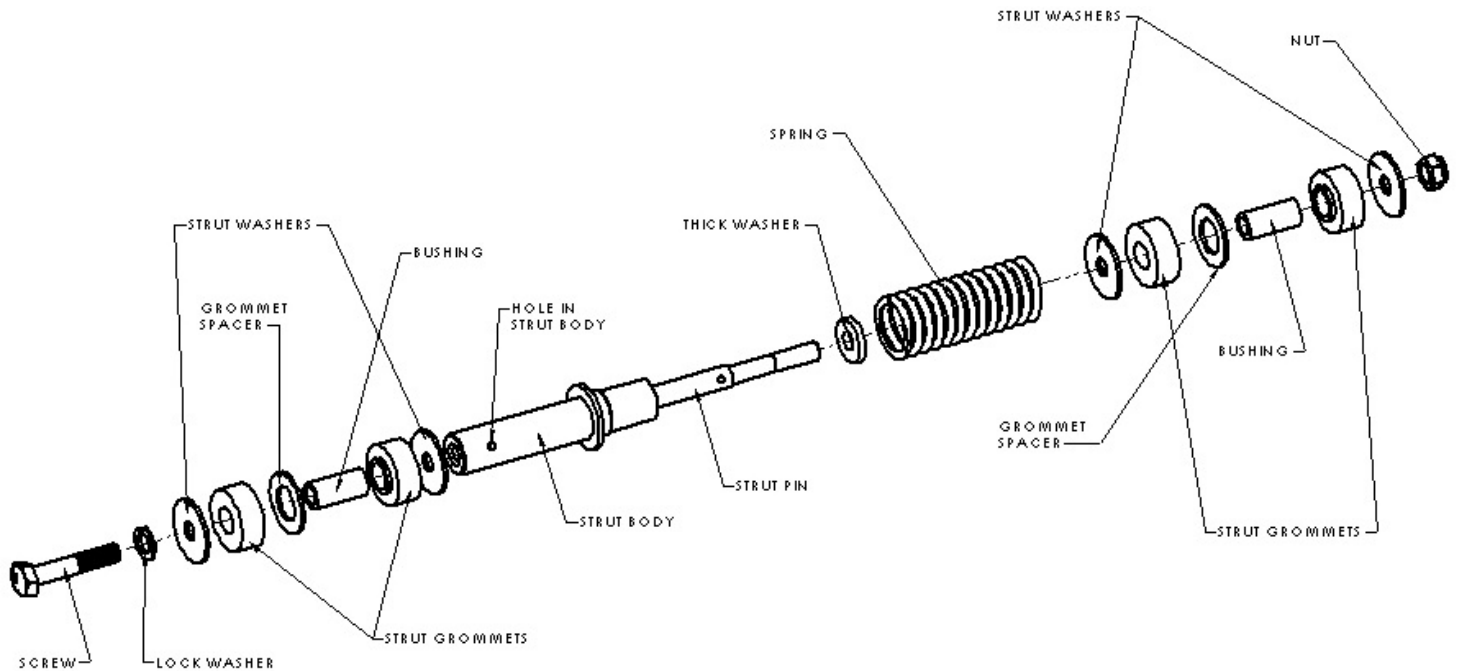

Figure 19. Super-Strut Assembly

1. Beginning with the REAR strut install the new strut body, washers, rubber grommets, bushings, grommet spacers, and bottom screw on the outer frame.

Note: When installing the rubber grommets, the two shouldered ends must face each other with the mounting bracket and grommet spacer between them as shown in Figure 20, "Replacing the Front Strut" on page 49.

2. Hand tighten until snug.

Replacing Super-Struts

3. Repeat Step 1 for the FRONT strut. Install the new strut pins, washers, rubber grommets, and top nuts on the inner frame as shown in the figure below. Hand tighten until snug.

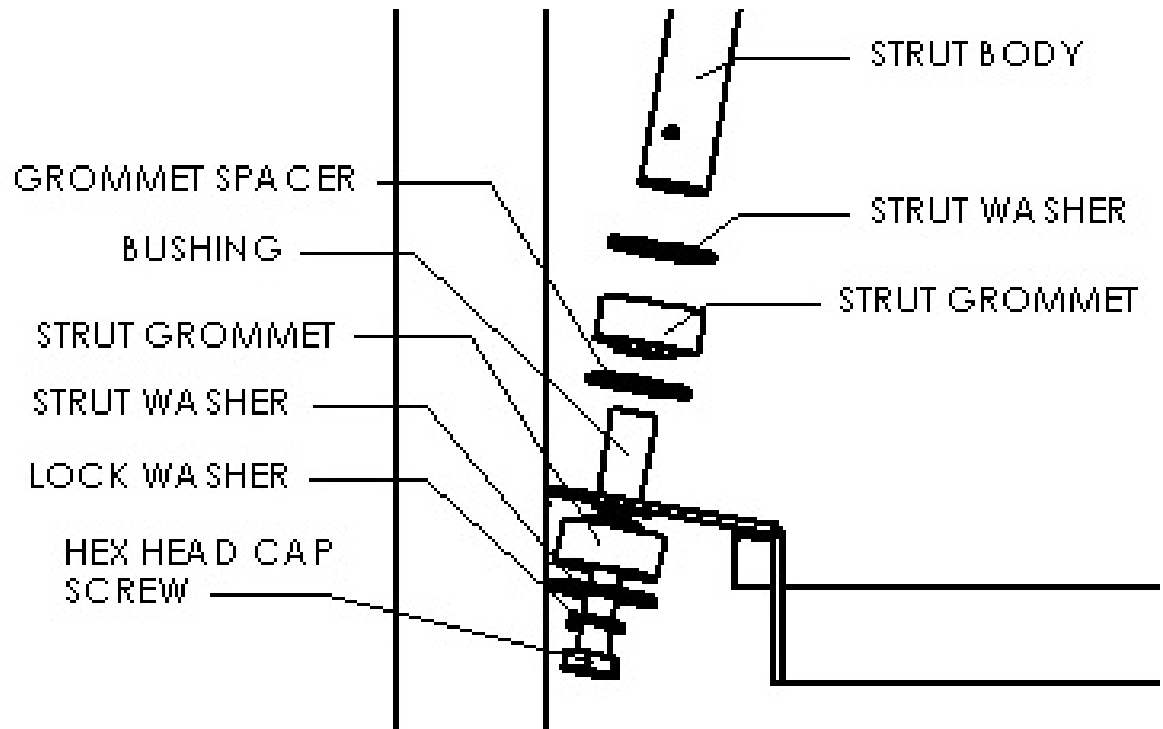

Figure 20. Replacing the Front Strut

4. Using the 2" x 4' board, lift the inner frame and install both springs on the strut bodies, then remove the blocks from under the inner frame.
5. Lift the inner frame again with the 2" x 4' board as a lever. This will allow you to align and insert the strut pins into the strut bodies.

Note: Use care when installing the pins in order to prevent damage to the inner bushing.

Replacing Super-Struts

6. Make sure that the springs are centered. Push with your thumb to click them into place.

Strut Pin

Strut Grommet

Figure 21. Replacing the Strut Shafts

7. Beginning with the FRONT strut, tighten the top nut to 37 Ft-lbs of torque.
8. Tighten the BOTTOM screw to 37 Ft-lbs of torque.
9. Moving to the REAR strut, tighten the TOP nut to 37 Ft-lbs of torque.