

HIGH POWER RADIO FREQUENCY WEAPONS:  
A POTENTIAL COUNTER TO U.S. STEALTH AND CRUISE  
MISSILE TECHNOLOGY

by

John A. Brunderman, Lieutenant Colonel, USAF

Center for Strategy and Technology

Air War College

Air University

Maxwell Air Force Base, Alabama

December 1999

Distribution A: Approved for public release; distribution is unlimited

## **Disclaimer**

The views expressed in this publication are those of the author and do not reflect the official policy or position of the United States Government, Department of Defense, or the Air War College Center for Strategy and Technology.

## *Contents*

	<i>Page</i>
DISCLAIMER .....	ii
ILLUSTRATIONS .....	iv
TABLES .....	v
ABSTRACT .....	vi
INTRODUCTION – A SCENARIO .....	1
TERMINOLOGY .....	5
BACKGROUND .....	7
CAPABILITIES .....	10
Beam Propagation .....	10
Microwave Effects .....	11
Target Susceptibility .....	13
Area Coverage .....	16
Insensitivity to Weather .....	16
Reduced Life Cycle Costs .....	17
CONSTRAINTS .....	19
Range .....	19
Fratricide .....	19
Targeting and Survivability .....	21
PROLIFERATION CONCERN .....	22
RF WEAPONS IN AN AIR DEFENSE ROLE .....	25
PROTECTIVE MEASURES .....	28
RECOMMENDATIONS .....	30
BIBLIOGRAPHY .....	34

## *Illustrations*

	<i>Page</i>
Figure 1: Example of an Antenna Pattern .....	21
Figure 2: Diagram of Former Soviet Union's Antiaircraft Microwave Weapon System .....	23
Figure 3: Effect vs Range for Multiple Targets .....	31
Figure 4: Effect vs Range for Multiple Devices .....	31

## *Tables*

	<i>Page</i>
Table 1: Possible RF/Microwave Protective Techniques .....	29

## *Abstract*

The emergent technology of high power radio frequency in a directed energy role has huge potential for military use, in both offensive and defensive roles. There are many applications for this type of technology, from minesweeping to anti-aircraft artillery to unmanned combat aerial vehicles. Given the current U.S. dominance in precision attack and air combat capability, new technologies might serve to challenge this advantage if an enemy can exploit them. This paper examines the question of whether U.S. tactics or strategy will have to change with these systems in the hands of an adversary, assuming they were used in an integrated air defense role to counter U.S. high-tech deep-strike capability. Specifically, could high power microwave systems become an effective defense against our standoff cruise missile and stealth technology and if so, could an adversary develop and deploy them without our knowledge in order to catch us unaware? Based on the findings, the conclusion recommends several avenues that the Air Force should pursue to prepare for these future weapons.

## **Chapter 1**

### **Introduction – A Scenario**

The news agencies had been covering the diplomatic negotiations for days. The ultimatum had passed hours before and everyone knew that air strikes were inevitable. Although the networks did not know the exact timing, they had placed daring reporters in country to capture the spectacular effects expected of U.S. precision weaponry. They had even contracted for satellite imagery from the numerous commercial systems available. The whole world sat on the edge of their seats to see how this would turn out.

Everything was planned perfectly. The simultaneous attack of communication nodes, command structures and the Integrated Air Defense System (IADS) with U.S. deep-strike precision cruise missiles and stealth bombers would set the stage for all that would come after. The enemy would either capitulate or suffer the piecemeal dismantlement of his entire infrastructure. The first weapons should be reaching their targets just about NOW...

Something was seriously wrong. CNN was reporting numerous explosions in business and residential areas of the city. The pictures of disfigured and bloodied men, women and children paraded across the screen. A CNN news crew had been killed in one of the explosions. Air Operations Center was reporting two downed B-2s. Satellite imagery was just coming in. It confirmed that scores of cruise missiles had missed their

targets and landed in civilian areas. SIGINT reports showed the IAD system still operational. The talking heads were screaming about war crimes for attacking civilian population centers. You call off the second wave of manned bombers. You wonder what you missed when your Aide informs you that the White House is on the phone.

The above scenario is a nightmare for any American commander. In a world of instant communications, even small tactical events can often take on strategic significance. Recent trends toward political aversion to the realities of combat, in particular the sensitivity toward casualties, are placing incredible constraints on the military commander and giving our adversaries leverage to use against the United States. In the Gulf War, the destruction of an underground command and control bunker that was also being used as an air raid shelter by the civilian populous sparked an outcry in the West and a change in coalition targeting. In Kosovo, after the accidental bombing of the Chinese embassy, the alliance imposed a moratorium on bombing in Belgrade.<sup>1</sup> As of this writing, the incident is still causing problems in U.S./China relations. When an F-117 pilot was shot down over Serbia, almost the entire Kosovo air effort was diverted into search and rescue operations until he was picked up. Should an adversary ever devise the means to significantly increase our own casualty rates or even precipitate our killing of their civilians, intentionally or not, they have a good chance of altering the course of the war, especially in small scale conflicts where U.S. national survival is not at stake. High power radio frequency weapons are a new technology on the horizon that might provide just such a means.

The scientific and military communities have known of the potentially damaging effects of radio frequency (RF) energy on electronics since the advent of radar. During



the Vietnam War, in July 1967, investigators determined that the energy from the USS Forrestal's main radar caused a devastating explosion when it penetrated faulty shielding in an air-to-air missile loaded on an F-4 fighter aircraft. The resulting damage ultimately cost the lives of 134 sailors and took seven months to repair.<sup>2</sup> Even after this affair, the U.S. put little effort into exploring this phenomenon for military use, except in basic research. The Soviet Union, however, had been seriously pursuing RF weapons research starting as early as 1949 and continued to do so. It was not until after President Reagan's announcement of his Strategic Defense Initiative (SDI) in March of 1983, coming on the heels of significant Soviet advancement in RF/microwave weapon technology in the late seventies, that the U.S. began its own push in this area.<sup>3</sup> Since then, advances in high power RF/microwave (HPM) generation capability have been coming regularly. The United States is currently developing operational systems in an attempt to capitalize on these discoveries. The former states of the Soviet Union, particularly Russia and Ukraine, have continuing programs in this area and are freely sharing their knowledge with those who can pay for it. Reports indicate that France, Germany, China, India and even Pakistan have invested in RF technology from the former Soviet Union. There are many applications for this type of technology, from minesweeping to artillery, to unmanned combat attack vehicles. The question before us is whether military tactics or strategy must change with these systems in the hands of an adversary. Of particular interest is whether an adversary could use high power RF/microwave technology in an integrated air defense role to counter U.S. high-tech deep-strike capability. Specifically, could high power RF/microwave systems become an effective defense against our standoff cruise missile and stealth technology and if so, could an adversary develop and

deploy them without our knowledge in order to catch us unaware? Finally, are there any preventative measures the U.S. should take to ensure that future commanders would never be faced with the scenario described above?

#### **Notes**

<sup>1</sup> Dana Priest, Washington Post, September 20, 1999, p 1.

<sup>2</sup> U.S. Congress. Joint Economic Committee Hearing: *Economic Espionage, Technology Transfers and National Security*. Opening Statement of Lieutenant General Robert L. Schweitzer, USA (Ret) to the Joint Economic Committee of the One Hundred Fifth Congress (June 17, 1997, ISBN 0-16-055880-9)

<sup>3</sup> Jeff Hecht, *Beam Weapons: The Next Arms Race* (Plenum Press: New York and London, 1984), p.1.

## Chapter 2

### Terminology

For the purposes of this paper, the technical details of high power microwave technology add little value, but it is important to understand some of the terminology, the basic concepts and how we got to where we are today. Once this framework is set, a discussion of the capabilities and constraints of microwave weapons and how one might use them in an integrated air defense system can proceed.

Microwave weapons fall into a category of directed energy weapons commonly referred to as high power Radio Frequency (RF) devices. Although the RF portion of the electromagnetic spectrum extends from below 3 kilohertz (KHz) to above 300 gigahertz (GHz), high power weapon research is generally limited from between 100 MHz to 35 GHz.<sup>4</sup> This is because moisture in the atmosphere has very little affect on a signal in this frequency range and is why most communication, navigation and radar devices operate there.<sup>5</sup>

The literature categorizes RF weapons according to the type of beams they produce, either wideband or narrowband, and often refers to the whole group under the heading of microwave weapons. Wideband devices generally operate in the lower frequency ranges (10 MHz to 1 GHz) and produce very short pulses (1 to 100 nanoseconds) with wide bandwidths (50% to 100% of the center frequency).<sup>6</sup> These

types of devices are called Ultra-Wideband (UWB) weapons. Narrowband devices generate longer pulses (1 microsecond) and produce RF radiation at a single frequency (between 1-35 GHz), with a very small bandwidth (nominally 1% of the frequency).<sup>7</sup> Narrowband devices are called High Power Microwave (HPM) weapons, although HPM is sometimes used to describe all microwave weapon technology.

The parameters used to characterize these systems include frequency, energy, average power, peak power, fluence, bandwidth, pulse width, dwell time and numerous others. Microwave designs can produce continuous or pulsed beams from single-shot or multi-shot systems. Understanding these highly technical concepts and their interdependence is necessary for the engineer, but for the operator, they tend to obfuscate the real issue of a weapon's viability on the battlefield. In general, for an integrated air defense, the best weapons are high frequency, wide bandwidth, pulsed power, multi-shot systems with narrow beam widths to better focus their energy on a distant target. Ultimately, a weapon's range, lethality and rapidity of fire are what matter to the war fighter and will determine how it is employed.

#### Notes

<sup>4</sup> David M. Sowders, Capt, USAF, et.al., *High Power Microwave (HPM) and Ultrawideband (UWB): A Primer on High Power RF*, PL-TR-95-1111, Special Report, Phillips Laboratory, March 1996. p 14.

<sup>5</sup> William J. McCarthy, Captain, USN. *Directed Energy and Fleet Defense: Implications for naval Warfare*. (Maxwell AFB, AL: Center for Strategy and Technology, Occasional Paper No. 10, Forthcoming). p.25.

<sup>6</sup> David M. Sowders. p 3.

<sup>7</sup> David M. Sowders. p 3.

## Chapter 3

### Background

Serious U.S. research into the effects of intense RF energy on electronic components began with the discovery of the electro-magnetic pulse (EMP) phenomenon associated with the detonation of a nuclear weapon. On July 8, 1962, after the U.S. tested a hydrogen bomb in the skies above a remote Pacific island, scientists were surprised to find effects as far away as the Hawaiian Islands, over 1000 miles distant. When the blast went off, 300 street lamps suddenly extinguished, many burglar alarms sounded and a large number of power supply systems failed when their safety switches tripped.<sup>8</sup> It took C.L. Longmire a year to develop the theoretical analysis to even explain what happened. In essence, a nuclear blast releases a pulse of energy across the low radio frequency bands (below 1 GHz) that produce transient voltages in electrical equipment, which often causes the electrical circuits to overload.<sup>9</sup> Nuclear physicist Edward Teller predicted in 1978, “If an eight-megaton hydrogen bomb were exploded at 500 kilometers above the middle of the United States, at least half of the country’s computers and electronic equipment would stop working.”<sup>10</sup> Both the United States and the Soviet Union devoted considerable effort into categorizing the effects of EMP on various systems. In the process, scientists developed high power radio frequency generators to simulate EMP so

they could test their systems without exploding a nuclear bomb. As time went by, investigation proceeded into the higher microwave frequencies.

The former Soviet Union was the first to begin research on applying high power RF/microwave technology to a weapon. In 1979, they achieved a breakthrough in manufacturing an experimental gigawatt-level microwave emission triode, a device critical to controlling the extremely high power levels needed in microwave beam technology. In 1983, they did it again by producing a 100-megawatt millimeter wave band transmitting tube. This was the first tube manufactured that could produce enough beam level power for microwave weapons experiments.<sup>11</sup> Before their collapse, the Soviet Union had a large and diverse RF weapons program and remnants of this work continue today within former Soviet Union countries.

The United States did not really begin microwave weapons research in earnest until the early eighties. Since then, scientists working with the High Power Microwave Division of the Air Force Research Laboratory (AFRL) at Kirtland AFB have made tremendous technical advances in plasma physics, energy storage and fast switching devices, all essential technologies for high power RF/microwave weapons development. They have also stepped up efforts to characterize the effects of RF energy in U.S. and foreign systems in order to improve understanding of both target vulnerabilities and protection measures. In fact, the technology has now matured to the point that several U.S. operational commands are pursuing weapon demonstration programs using high power microwave devices. The USAF Scientific Advisory Board predicted that high power microwave weapons would be a well-established technology by the year 2015.<sup>12</sup> They should make for an interesting world!

### Notes

<sup>8</sup> Zhu Zhihao. Trends of Microwave Weapon Development. (National Air Intelligence Center: Translated by Edward A. Suter, NAIC-ID(RS)T-0632-95, 4 January 1996), p. 1.

<sup>9</sup> E. Van Keuren and Dr. J. Knighten. *Implications of the High-Power Microwave Weapon Threat in Electronic System Design*. IEEE International Symposium on Electromagnetic Compatibility (1991: Cherry Hill, NJ, August 12-16, 1991), p. 370.

<sup>10</sup> Edward Teller. "Special Issue on EMP," IEEE Trans. A-P. January 1978.

<sup>11</sup> Zhu Zhihao. p. 7.

<sup>12</sup> USAF Scientific Advisory Board, *New World Vistas: Air and Space Power for the 21<sup>st</sup> Century*, Directed Energy Volume (Washington, DC: USAF Scientific Advisory Board, September 1996), p. 60.

## Chapter 4

### Capabilities

Few weapon systems have ever *revolutionized* the way war is conducted. For every offense, there is a defense and visa versa. This does not mean, however, that new weapon systems will not *affect* the way war is conducted. If high power microwave systems live up to their expectations, they certainly have the potential to change the way wars are fought. The following paragraphs describe both the benefits and limitations of this new technology.

#### Beam Propagation

A fundamental principle of any energy weapon is that as the distance from the weapon increases, the energy reaching the target decreases. Normal omni-directional antennae, like those used in radio and television, produce steady-state electromagnetic fields that attenuate energy in all directions at a rate proportional to the inverse of the square of the distance from the source ( $1/D^2$ ). Such attenuation is too restrictive for beam weapons. Fortunately, scientists discovered that different antenna designs could produce special electromagnetic fields that allow energy to propagate in some directions with less attenuation than in steady-state fields. These fields, called transient-state fields, allow energy to propagate in a beam at a rate of  $1/D^\alpha$ , where  $0 < \alpha < 2$ . Transient-state fields,



therefore, provide microwave weapons with the ability to direct the beam while simultaneously capitalizing on the lower attenuation to extend the range.<sup>13</sup>

## **Microwave Effects**

High power RF/microwave energy can affect anything that responds to electromagnetically induced voltages and currents, which includes electronics, materials and personnel. Two mechanisms are at work within objects caught in a high power microwave beam, molecular heating and electrical stimulation.

Molecular heating occurs when powerful sinusoidal waves, produced by narrow band microwave devices, cause the molecules of a material to rub together at the frequency of the microwave field.<sup>14</sup> The effect is the same as that found in a standard microwave oven. Materials containing liquid or carbon molecules are quite susceptible to this kind of radiation. The idea is that an extremely high power microwave signal directed at a distant target could potentially raise the temperature of fuel above its flash point, prematurely explode the warhead, heat the composite structures to point of failure, or kill the occupants outright by boiling their brains. The power required to do this, however, is quite large and would require a significant dwell time on target.

A more efficient mechanism for attack is electrical stimulation. The power levels required to induce transient voltages and currents in electrical devices are much smaller than for molecular heating. This allows for much longer engagement ranges and much shorter dwell times when attacking targets with electrical components. Under electrical stimulation, microwave energy, narrow or wide band, couples with any electrically conductive material in the beam to stimulate electron flow in the material, thereby producing transient currents and voltages. Electrically conductive materials in the target

act like little antennae to the high power microwaves in the same way a normal antenna picks up low power radio waves. Transient currents interfere with the normal operation of electrical components, inducing spurious signals that confuse the system or even damage sensitive components. At sufficiently high power levels, these currents can actually produce electrical arcing or sparks across conductors. Inadvertently leaving a metal “twist-tie” or aluminum foil on a package placed in a common microwave oven can present impressive evidence of this phenomenon. In any case, sparks are always bad for electronics and could even ignite fuel vapors or explosive warheads, as occurred on the USS Forrestal in Vietnam. When a beam enters a target, high power RF radiation bounces around inside the container, creating constructive and destructive interference that produces “hot” and “cold” spots (regions of high and low electromagnetic field strengths) within small distances of one another. These hot spots can be many times stronger than the incident field, thereby exposing components situated at these nodes to even higher field strengths.<sup>15</sup>

AFRL’s Advanced Weapons and Survivability Directorate recognizes four major categories of electronic effects that can be produced by high power RF: upset, lockup, latch-up and burnout.<sup>16</sup>

**Upset** is a temporary alteration of the electrical state of one or more nodes in such a way that they no longer function normally. Once the signal is removed, however, normal function returns with no permanent effects. Jamming is an example of this type of effect, where a sensor might lose lock because of interference.

**Lockup** produces the same effects as upset, but an electrical reset is required to regain functionality, even after the signal is removed. If a computer were to freeze after exposure to an RF signal so that it had to be rebooted, this would be an example of lockup.

**Latch-up** is an extreme form of lockup in which a node is permanently destroyed or electrical power is cut off to the node. A fuse blowing or transistors failing on a circuit board due to overloads from microwave radiation are two such examples.

**Burnout** is the physical destruction of a node where the current becomes so great that conductors actually melt. This usually occurs within smaller wires or at junction nodes where multiple wires come together and often involves electrical arcing. The damage to household electronics caused by a lightning strike is an example of burnout.

Any of these mechanisms have military utility depending on the mission. In an air defense role, lockup, latch-up and burnout can produce the desired effect of thwarting a precision attack by disrupting the guidance system of the weapon. Even upset can be useful in denying navigation signals to a precision weapon to reduce its accuracy. Against reusable platforms like aircraft, the mechanisms of latch-up or burnout are more desirable because they inflict actual damage on the target, which must be repaired if the aircraft ever makes it back to home base. This kind of damage can be especially difficult to isolate because microwave energy can affect every internal component of the system. Lengthy troubleshooting procedures are likely, which keeps the aircraft out of service longer. Finally, significant system wide damage will put a strain on the logistical capability to bring in sufficient spare parts to keep the systems in working order.

### **Target Susceptibility**

The rate and degree to which a target is affected by RF/microwave energy depends upon numerous factors of both the beam itself (range, frequency, burst rate, pulse width, etc) and the design of the target (shielding, filters, shunts, etc). These factors are extremely complicated, and the detailed discussion far beyond the scope of this

paper. Nevertheless, a basic understanding of what makes targets vulnerable to high power RF radiation is warranted.

In order for an RF signal to affect the internal workings of a target, it must first penetrate the external case. A seamless external case, made entirely of conducting metal, with no sensors, apertures or connections to the outside world, would act as a perfect “Faraday cage” and totally shield any internal components from external signals. However, most aircraft and precision weapons have sensors, flight control surfaces and other apertures that allow entry of RF radiation. RF radiation uses two mechanisms to enter a target, called front-door coupling and back-door coupling.

Front-door coupling occurs when RF energy enters the system through a sensor or antenna designed to receive this type of radiation. The radiation may be in-band or out-of-band with respect to the receiving system. In-band refers to radiation that is of the same frequency range as the antenna, meaning that the antenna actually amplifies the signal and passes the energy directly through to the internal components. In-band front-door coupling is the most efficient and destructive coupling method. Out-of-band refers to radiation outside the designed frequency range of the antenna or sensor. The system will usually attempt to filter this type of radiation, although the power levels associated with high power RF beams might still overwhelm its circuits. Narrow-band high power microwave devices are most suited to front-door coupling because all their energy can be focused into the narrow frequency range of the sensor or antenna. Ultra Wide Band microwave devices are not as effective with front-door coupling because most of their energy is contained in the out-of-band frequencies, which systems are designed to filter.

Back-door coupling encompasses every other way RF energy can penetrate a system. RF energy may enter through cracks, seams, seals, conduits, cable runs, apertures, solar cells, optical sensors, etc. Ultra-wideband (UWB) radiation is particularly effective at back-door coupling because of the wide range of wavelengths involved, from 1 mm (gigahertz frequencies) to 3 meters (megahertz frequencies), which allows them to penetrate from multiple points.<sup>17</sup>

Regardless of the method, once in, high power microwave energy can wreak havoc on electronic components, especially integrated circuits and other microelectronics found in sophisticated weapon systems. Modern semiconductor design based on Metal Oxide Semiconductor technology, on which most of our critical systems depend, is extremely vulnerable to electromagnetic pulses.<sup>18</sup> Furthermore, as electronics become more densely packed, more energy efficient and operate at higher speeds, they will become even more susceptible to high power RF/microwave radiation.<sup>19</sup>

The United States has conducted extensive research over the years to understand and minimize the effects of electro-magnetic pulse (EMP) from nuclear detonations on our systems. Unfortunately, EMP protective measures are not as effective against high power microwave (HPM) and ultra-wideband (UWB) waveforms. This is because EMP frequencies fall mostly below 1 GHz, with pulse widths in the range of 50 nanoseconds to 1 microsecond. The higher frequencies and shorter pulse times of HPM and UWB are generally inside the response time of most limiters, so RF energy passes relatively unattenuated into the system.<sup>20</sup> The principle is the same as those self-darkening glasses that adjust themselves according to the amount of light present. It takes a finite amount of time to sense the light and adjust the pigment to limit the energy passing through. If

one were exposed to a camera flash while wearing a pair of these glasses, they could not adjust fast enough to keep one's vision from developing that persistent white spot.

Another important factor that determines how RF radiation will affect a target is the incident power level at the target surface. The higher the power, the more likely it will produce damage. For air defense applications, as a target flies closer to a high power RF radiation source, the effects can be expected to become greater.

### **Area Coverage**

Microwave weapons are particularly promising as air defense weapons because they have a full volume engagement zone. Unlike a laser, which can only illuminate one target at a time, a microwave weapon can simultaneously illuminate every target within the beam's path, near or far. The energy delivered to each target is almost wholly dependent upon its range from the source. Another benefit is that microwave weapons have a wider field-of-view relative to other directed energy weapons, like lasers. Beam widths can range into the tens of degrees. The narrowest beam produced to date is about one degree. Wider beams require less precise tracking, but also reduce the power delivered to the target, since the energy spreads out over a larger area. Nevertheless, the ability to simultaneously engage multiple targets is a unique and valuable capability.

### **Insensitivity to Weather**

Another positive attribute of microwave energy is its insensitivity to weather. Lasers, which operate in the visible or infrared regions of the spectrum, are greatly affected by moisture in the atmosphere. Microwave beams, however, just like radio, television and radar signals, are mostly unaffected by clouds, rain, snow, dust and most

other atmospheric conditions. Attenuation becomes more pronounced above 10 GHz, but some visibility windows exist that allow HPM devices to operate effectively even in this region.<sup>21</sup> Having a truly all-weather weapon that engages at the speed of light will be a great addition to any nation's arsenal.

### **Reduced Life Cycle Costs**

To be truly effective, a weapon system not only must be lethal, but also supportable in the field and exist in enough numbers to provide overlapping coverage and endure attrition in actual combat. Because microwave systems have far fewer moving parts compared to typical air defense weapons, support in the field should be much easier. Also, unlike conventional air defense weapons, microwave weapons require no logistical tail to keep them stocked with missiles. Fuel is their only expendable. Their "bullets" are simply electrical energy derived from their generators, so they never have to reload. So long as the generator keeps running, a microwave weapon can fire as often and as rapidly as needed. These factors afford the potential for greatly reduced life-cycle costs, which makes RF weapons an attractive option for nations with less logistical capability than the United States.

#### **Notes**

<sup>13</sup> Zhu Zhihao. p. 3.

<sup>14</sup> U.S. Congress. Joint Economic Committee Hearing: *Radio Frequency Weapons and Proliferation: Potential Impact on the Economy*. 105<sup>th</sup> Congress, 25 February 1998. Opening Statement of Mr. David Schriener. *The Design and Fabrication of a Damage inflicting RF Weapon by 'Back Yard' Methods*. Transcript provided from internet site <http://cryptome.org/rfw-jec.htm>

<sup>15</sup> David M. Sowders. p. 75.

<sup>16</sup> David M. Sowders. p 81.

<sup>17</sup> David M. Sowders. p 4.

<sup>18</sup> U.S. Congress. Joint Economic Committee Hearing: *Radio Frequency Weapons and Proliferation: Potential Impact on the Economy*. 105<sup>th</sup> Congress, 25 February 1998. Opening Statement of Dr Ira W. Merrit. *Radio Frequency Weapons and Proliferation:*

### Notes

*Potential Impact on the Economy.* p. 12. Transcript provided from internet site <http://cryptome.org/rfw-jec.htm>

<sup>19</sup> A.E. Pevler. *Security Implications of High-Power Microwave Technology* (IEE International Symposium on Technology and Society, 1997), p. 1. Article downloaded from [http://www.infowar.com/civil\\_de/civil\\_090597a.html-ssi](http://www.infowar.com/civil_de/civil_090597a.html-ssi)

<sup>20</sup> Dr Ira W. Merrit. p. 15.

<sup>21</sup> David M. Sowders. p 17.



## **Chapter 5**

### **Constraints**

Microwave weapons are not the panacea for all our weapon woes. As with anything in the real world, there are limitations and constraints that mitigate the ideal. High power microwave devices are no exception. The technology has limitations in range, issues with fratricide against friendly forces, and targeting and survivability concerns.

#### **Range**

Range is one limiting factor in microwave weapons. Depending on the design, ranges extend anywhere from one to ten kilometers. One of the difficulties posed by using RF energy is that at sufficiently high power levels, the beam strips the electrons from the air molecules and forms plasma. The plasma then reflects and absorbs the RF energy. This phenomenon is known as “atmospheric breakdown” and ultimately limits the energy and hence the range of these kind of devices. However, research into pulsed power and pressurized waveguides shows promise in overcoming this limitation.<sup>22</sup>

#### **Fratricide**

Fratricide is probably the number one drawback in using high power RF weapon technology. From an operational standpoint, microwave devices are not very

discriminating weapons. The advantage of a full volume engagement zone as described above has its drawbacks. Radiating at an enemy will affect not only the target, but also anything else in the beam's path. Since hardening existing systems is relatively ineffective and replacing one's entire inventory with redesigned hardened systems would seem cost prohibitive (to be discussed later), it is likely that one's own systems would be as vulnerable as the intended target and often closer. This puts any friendly forces on the ground or in the air, near or far, that fall within the beam's footprint, at significant risk, thereby potentially limiting a defender's ability to position his/her own forces in the most optimal manner because of the fratricide issue. It might be possible to elevate the beam to provide overlapping coverage and keep ground forces out of harm's way, but that would introduce gaps in coverage that cruise missiles or aircraft could exploit.

Another problem is the fact that RF antennae produce side-lobes that radiate away from the direct line of fire, causing further fratricide issues. UWB devices are particularly susceptible to this phenomenon, which makes integrating with other weapons on a battlefield problematic. An example of an antenna pattern showing directionality versus gain is illustrated in Figure 1. Close inspection of the plot will show that there is a back lobe one must contend with that raises concerns over protecting the radiating equipment to prevent self immolation.

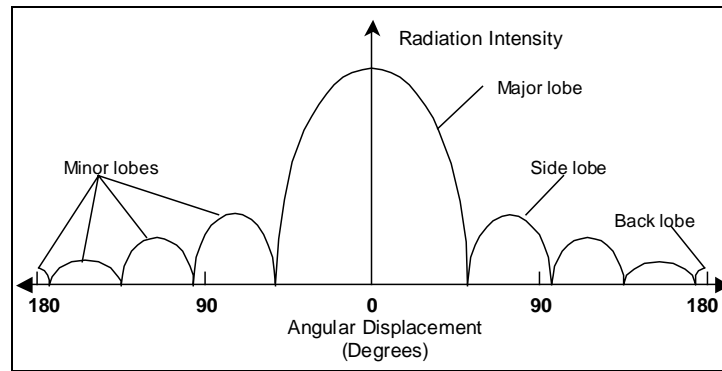

**Figure 1: Example of an Antenna Pattern <sup>23</sup>**

## Targeting and Survivability

Putting integration aside, targeting a system and surviving the response are always concerns. First, one must find the target to engage it. Advances in speed, range and stealthiness of cruise missiles and aircraft make this more difficult every year. If a system has to radiate to locate a potential target, or when it radiates to attack one, it lets the enemy know where it is. U.S. forces have proven on more than one occasion that if they can find you, they can kill you. Microwave weapons will not change this, however they just might make it more costly to do so by necessitating simultaneous attacks on multiple axes. The bottom line is that every weapon system has its weaknesses and military planners need to be prepared to exploit them.

### Notes

<sup>22</sup> David M. Sowders. p 19.

<sup>23</sup> C.A. Balanis, *Antenna Theory, Analysis, and Design* (New York: Harper & Row Publishers, p. 21, 1982.

## Chapter 6

### Proliferation concern

Given the overwhelming superiority of U.S. conventional weaponry as highlighted in the Gulf War and more recently in Kosovo, potential adversaries are looking for some way to close the gap. Microwave weaponry may provide the means. The United States has publicly embraced *precision engagement* as one of its main operational concepts in Joint Vision 2010. The goal of *precision engagement* is to provide a greater assurance of delivering the desired effect, lessen the risk to our forces, and minimize collateral damage.<sup>24</sup> To do this, the U.S. plans to depend even more heavily on standoff precision capability and low observable technologies than it does today.<sup>25</sup> As our forces pursue this technological course to increase our combat effectiveness, the U.S. might be introducing a vulnerability that can be exploited by an adversary. In essence, high power microwaves weapons might turn our strength into our “Achilles Heel”.

As mentioned before, the United States is not the only nation investing in high power directed energy weapons. The former Soviet Union was the world leader in directed energy research through the early 1980s. Following its breakup, former member states, especially Russia, have been less than bashful about sharing their expertise with other nations. In testimony before Congress in 1997, Lieutenant General Robert

Schweitzer, US Army (Ret) related from unclassified sources that Russia, Ukraine, China, the United Kingdom, Australia and France were well advanced in the field, while Germany, Sweden, South Korea, Taiwan and Israel were emerging powers.<sup>26</sup> He also postulated that pariah nations had both the incentive and the financial resources to develop or procure such weapons. More recent reports show that India, Pakistan and even Sweden are investigating RF weaponry. The threat is real whether the capability exists yet or not. In a 1998 Congressionally mandated report, the Pentagon exposed China's action in pursuing the development of directed energy laser and high power microwave weapons for the express purpose of destroying satellites, aircraft and missiles.<sup>27</sup> Zhu Zhihao, a Chinese engineer working in the field, published a detailed description of a former Soviet Union's mobile anti-aircraft microwave weapon system.<sup>28</sup>

Figure 2 is a diagram of such a system.

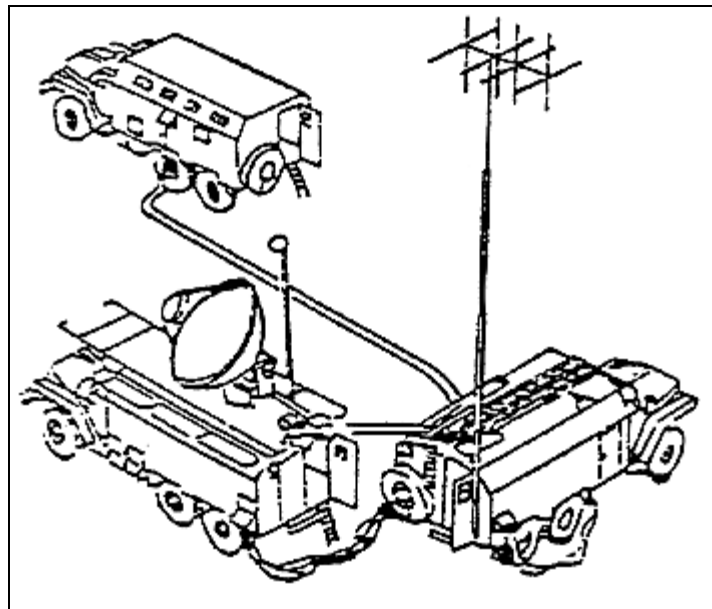

**Figure 2: Diagram of Former Soviet Union's Anti-aircraft Microwave Weapon System**

The system weighs approximately 13 tons and consists of three separated (to avoid interference) cross-country vehicles, with the generator and fuel in one, the search radar in another, and the microwave weapon in the third. Zhihao reports the weapon can radiate one-gigawatt-power microwaves with an effective range of one to ten kilometers.<sup>29</sup> Whether this could effectively disrupt U.S. precision strike capability has yet to be determined, but research is ongoing to determine U.S. vulnerabilities to these weapons.

Proliferation is of considerable concern because there are no internationally controllable components in a high power microwave system, which makes tracking them difficult. If various nations build these systems and put them on the open market for anyone to buy, the U.S. may be surprised one day to find itself facing a different kind of enemy. The one advantage the U.S. does have, however, is that its national technical means should be able to identify any country that is testing such systems, which should give it some time to plan.

#### Notes

<sup>24</sup> *Joint Vision 2010*, p. 21.

<sup>25</sup> *Joint Vision 2010*, p. 21.

<sup>26</sup> U.S. Congress. Joint Economic Committee Hearing: *Radio Frequency Weapons and Proliferation: Potential Impact on the Economy*. 105<sup>th</sup> Congress, 17 June 1997. Opening Statement of Robert L. Schweitzer, Lt Gen, US Army (Ret). *Radio Frequency Weapons and the Infrastructure*. Transcript provided from internet site <http://cryptome.org/rfw-jec.htm>

<sup>27</sup> Robert Wall. *Directed-Energy Arms Sought by China*. *Aviation Week & Space Technology*, 9 Nov 98, Vol 149, Issue 19, p. 35.

<sup>28</sup> Zhu Zhihao. p. 8.

<sup>29</sup> Zhu Zhihao. p. 8.

## Chapter 7

### RF Weapons in an Air Defense Role

Over the last decade, the United States has conducted impressive air campaigns against adversaries in the Gulf War, Bosnia and most recently Kosovo. The Air Force's first priority has always been to gain and maintain air superiority, which we have achieved through aggressive attacks on the enemy's communications and integrated air defense system (IADS). U.S. military commanders increasingly rely on cruise missile and stealth technology to accomplish this mission. Given the limited number of precision weapons and stealth platforms available, early takedown of the IADS system is essential to minimize risk to follow-on U.S. forces. In fact, the success of the entire air offensive can hinge on this opening sequence.

An enemy's potential ability to blunt America's initial onslaught using microwave weapons is particularly disturbing because of our reliance on sophisticated, precision-guided standoff weapons. The same microelectronics that allows these weapons to hit their targets with such precision are also the most likely to be adversely affected by microwave energy.<sup>30</sup> Cruise missiles might be particularly susceptible because their attack profile rarely follows a ballistic trajectory, hence any malfunction in their guidance system will force the bomb off target. Not only would the target not be destroyed, the

likelihood of collateral damage would be greatly increased, thus becoming problematic for the political leadership.

During attacks on Baghdad in the Gulf War, CNN showed waves of antiaircraft fire streaming into the sky in an attempt to catch over-flying stealth aircraft. The Iraqis consumed huge amounts of ammunition, yet the technique remained ineffective because of the pinpoint accuracy requirement of antiaircraft artillery. High power microwave devices, however, may overcome these limitations. First, they have “deep magazines” which allow them to fire continuously without fear of running out of ammunition. Second, their wide beams and longer ranges make it possible to irradiate wide swaths of the sky with microwave energy. These combine to make it much more difficult for attacking stealth aircraft to avoid the threat. If engaged, the energy-absorbing aspect of stealth technology would actually work against the aircraft, increasing the coupling effect and making it harder to disperse the energy. The resulting damage might be disastrous to stealth aircraft.

Thus, U.S. reliance on cruise missile and stealth technology in the opening salvos of an operation to reduce the surface-to-air threat and degrade command and control could become questionable--or at least much more expensive and difficult to accomplish--should high power microwave systems be widely deployed. In addition, the likely increase in U.S. and non-combatant casualties would have obvious political consequences at home. In today's political environment, with seeming expectations of little to no casualties on *either* side, this outcome would be particularly troublesome. Whether any strategic ramifications on the war effort would result, would be largely dependant on leadership in the White House and Congress at the time. In any case, the



potential of such a scenario is viable enough to start making serious preparations to counter it.

### **Notes**

<sup>30</sup> Dr Ira W. Merrit. p. 14.

## Chapter 8

### Protective Measures

With the likely proliferation of high power RF systems in the future, hardening against their effects is a prudent option. During the Cold War, the United States military put considerable effort into research programs to counter the effects of nuclear EMP. Unfortunately, with the collapse of the Soviet Union, much of the incentive for doing so collapsed also, partly because of the exuberance for the end of the Cold War and partly because of the high cost of designing and testing hardening efforts. Budget constraints, attempts to save on acquisition costs by eliminating many MIL specifications and the perception of a reduced world threat precipitated the de-emphasis of hardening procedures in weapons development throughout the 1990s. The time may well be at hand to reinvigorate the process.

Many protective techniques against high power microwaves are similar to those employed for nuclear EMP protection. However, much greater care is required to protect against microwave energy due to the higher frequencies involved, the minute openings through which they can penetrate, and the conductors and devices into which they can couple. For example, an EMP hardening technique, that employed honeycomb filters based on waveguide-beyond-cutoff principles, may actually serve to focus microwave energy into a system.<sup>31</sup> Table 1 lists possible RF/microwave protective measures.

- ❑ Shielding-Filtering
- ❑ Extreme care in eliminating very small openings
- ❑ Flexible metal cable jackets preferable to braid
- ❑ Gasketing
- ❑ Multi-layer shielding to eliminate LOS penetration
- ❑ Welded structures
- ❑ Minimization of metal fixtures and fastenings in non-metallic structures
- ❑ Use of optical communications, e.g., fiber optics
- ❑ Narrow beam antennas with minimum side lobes
- ❑ Upgraded miniature coaxial spark gaps
- ❑ Conductive foil over joints
- ❑ Internal optical connections
- ❑ Acoustic or RF power transmission

**Table 1: Possible RF/Microwave Protective Techniques<sup>32</sup>**

Given the above measures, maintainers must then exercise extreme care to prevent hardness degradation during the life cycle of the system. Even if a system was perfectly shielded in the design and fabrication phase, bending, twisting, vibration, corrosion and migration of loading materials in gaskets and elastomers could still introduce minute penetrations that might permit HPM entry. Experience and testing has shown that it is very difficult to maintain the hardness built into the original system beyond the first six months.<sup>33</sup> Nevertheless, high power RF weapons have too much destructive potential to do nothing to counter them.

#### **Notes**

<sup>31</sup> E. Van Keuren and Dr. J. Knighten. p. 371.

<sup>32</sup> E. Van Keuren and Dr. J. Knighten. p. 371.

<sup>33</sup> David M. Sowders. p 89.

## **Chapter 9**

### **Recommendations**

Given the rate at which high power radio frequency weapons are maturing and their potential adoption within the integrated air defense system of an adversary, the United States needs to look seriously into the technology, tactics and strategy necessary to counter their effects on the battlefield before faced with the prospect in a real shooting war.

To start, the United States needs to increase testing of both its current and future weapon systems to determine their actual vulnerability to high power RF. To help the military planner, metrics need to be developed that characterize microwave weapons in terms of their effect on a target at various distances. This is not a simple or inexpensive task, given the inherently destructive nature of the testing. Nevertheless, the utility of such metrics would be well worth the cost and effort to derive them. Figures 3 and 4 provide examples of the type of metrics that could be quite useful to the military planner.

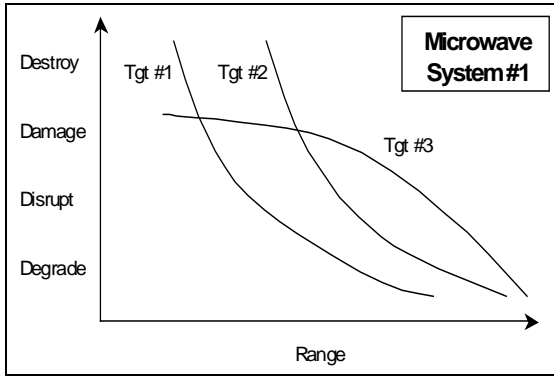

**Figure 3:** Effect vs Range for Multiple Targets

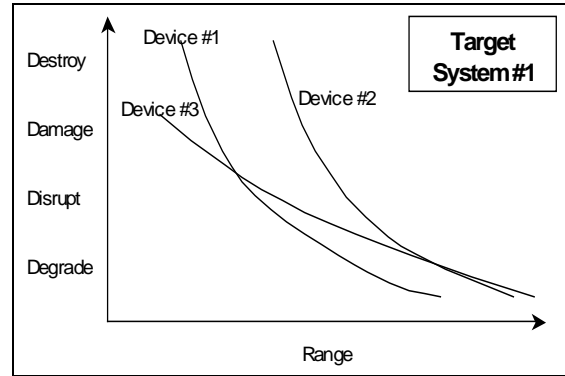

**Figure 4:** Effect vs Range for Multiple Devices

They would allow one to calculate threat rings and plan strike routes to minimize the risk to a mission, or to develop an air defense lay down to maximize lethality when using these weapons. They could also be used to determine the appropriate mix of weapons needed to overwhelm the defenses.

Next, the United States needs to increase research into hardening techniques against high power RF and, if possible, apply them to all our high value air assets. Acquisition agencies must demand high power RF hardening designs from the outset in new programs. At the very least, the Air Force needs to focus on those cruise missile and stealth platforms designed to take down the enemy's air defense system. If retro-hardening is impossible in these older systems, new munitions for this role would need to be developed. Of equal importance would be the development of a microwave-hardened RF homing missile, similar to the high speed anti-radiation missile (HARM) that takes down surface-to-air radars. This would allow special units to attack high power microwave defenses by homing in on their beams, thereby degrading enemy defenses to the point where older non-hardened system could be used.

As a final precaution to prepare for the future, operational tactics to counter high power RF weapons should be developed under the assumption that offensive weapons cannot be totally hardened against RF effects. Perhaps overwhelming the defenses using multi-axis attacks may be one method to counter this weapon. In any case, the experts can derive the most appropriate methods provided they have the information they need do so, which takes us back to testing.

The bottom line is that if high power RF weapons live up to their potential, the ability of our current generation of stealth and cruise missile weapons to accomplish high-risk missions could be significantly degraded. If left unchecked, directed energy weapons could challenge the very ability of U.S. forces to gain and maintain control of the air. Control of the air is the basic tenet of U.S. Air Force doctrine and considered the enabler for all other air missions. Without control of the air, U.S. commanders would be forced to accept appreciably higher aircraft loss rates or employ ground forces without shaping the battlefield and without the advantages of air support. In either case, the likely outcome would be higher casualty rates, lengthier conflicts and increased material costs.

Without effective counters to this technology, the proliferation of high power RF weapons throughout a given region would further complicate the political decision on when and how to get involved militarily. The current political sensitivity to even minimal U.S. casualties provides leverage that an adversary can apply to thwart U.S. strategic objectives. As military officers, we owe it to the national command authorities to mitigate this effect as much as possible.

There is still time. No one has yet to deploy an operational high power RF weapon in an integrated air defense role. With proper planning and investment, the United States will retain its immense superiority in the air, while easing the pressures on the national command authorities in their pursuit of the national security strategy.

## *Bibliography*

- AGARD Conference Proceedings 564, *High Power Microwaves (HPM)*, Sensor and Propagation Panel Symposium. Ottawa, Canada: NATO DRG Panel, 2-5 May 1994.
- American Physical Society Study Group. "Science and Technology of Directed Energy Weapons". To be published in *Reviews of Modern Physics*. April 1987.
- "Assessing Vulnerability to Radio Frequency Weapon Attack." Online Internet, 6 December 1999. Available from <http://www.ngic.ic.gov/products/cables/st/1216002aug99.html>
- "Australia Said to Have Bought Terror 'Bomb'." John Fairfax Holdings Limited 1998, 23 January 1998. On-line. Internet, 4 December 1999. Available from [http://www.info-sec.com/denial\\_012308a.html-ssi](http://www.info-sec.com/denial_012308a.html-ssi)
- "Directed Energy Warfare Susceptibility and Hardening." BAA 742. On-line. Internet, 4 December 1999. Available from <http://www.nrl.navy.mil/baa/baa742.html>
- Executive Intelligence Review. *Electromagnetic-Effect Weapons: The Technology and the Strategic Implications*. Wiesbaden, Germany. Dinges and Frick, February 1988.
- Fenstermacher, D. "Arms Race: The Next Generation." *Bulletin of the Atomic Scientists*, Vol. 47 Issue 2 (March 1991), p. 29.
- Fusion Energy Foundation, Scientific Staff. *Beam Defense: An Alternative to Nuclear Destruction*. Fallbrook, CA: Aero Publishers, Inc., 1983.
- Hecht, Jeff. *Beam Weapons: The Next Arms Race*. New York and London: Plenum Press, 1984.
- Hillaby, Bill. "Directed Energy Weapons Development and Potential." Defence Associations National Network, National Network News, Vol 4 No. 3. On-line. Internet 9 November 1999. Available from [http://www.sfu.ca/~dann/nn4-3\\_12.htm](http://www.sfu.ca/~dann/nn4-3_12.htm)
- Joint Warfighting Center. Concept for Future Joint Operations: Expanding Joint Vision 2010. May 1997.
- Kopp, Carlo. "The E-Bomb—A Weapon of Electrical Mass Destruction." Department of Computer Science, Monash University, Clayton, Australia. On-line Internet 4 December 1999. Available from [http://infowar.com/mil\\_c4i/mil\\_c4i8.html-ssi](http://infowar.com/mil_c4i/mil_c4i8.html-ssi).
- McCarthy, Captain William J., (USN). Directed Energy and Fleet Defense: Implications for Naval Warfare. Occasional Paper No 10. Maxwell AFB, AL: Center for Strategy and Technology, Air War College, September 1999. Forthcoming.
- Pevler, A. E. "Security Implications of High-Power Microwave Technology." IEE International Symposium on Technology and Society, 1997. Dallas, TX: Texas Engineering Solutions, 21 October 1999. On-line. Internet. Available from [http://www.infowar.com/civil\\_de/civil\\_090597a.html-ssi](http://www.infowar.com/civil_de/civil_090597a.html-ssi)
- Siniscalchi, Colonel Joseph. Non-Lethal Technologies, Implications for Military Strategy, Occasional Paper No 3. Maxwell AFB, AL: Center for Strategy and Technology, Air War College, March 1998.



- Sowers, Captain David M, et al. High Power Microwave (HPM) and Ultrawideband (UWB): A Primer on High Power RF. Special Report from Phillips Laboratory. Advanced Weapons and Survivability Directorate. Kirtland AFB, NM: Air Force Materiel Command, March 1996.
- Teller, Edward, "Special Issue on EMP," IEEE Trans. A-P. January 1978.
- The White House. A National Security Strategy for a New Century. October 1998.
- U.S. Congress. Joint Economic Committee Hearing: Radio Frequency Weapons and Proliferation: Potential Impact on the Economy. 105<sup>th</sup> Congress, 25 February 1998. Includes opening statements of James O'Bryon, David Schriener, Dr. Ira Merritt and Dr. Alan Kehs.
- U.S. Congress. Joint Economic Committee Hearing: Economic Espionage, Technology Transfers and National Security. Opening Statement of Lt. Gen. Robert L. Schweitzer, U.S. Army (Ret). 105<sup>th</sup> Congress, 17 June 1997.
- USAF Scientific Advisory Board. New World Vistas: Air and Space Power for the 21<sup>st</sup> Century. Directed Energy Volume. Washington, D.C.: USAF Scientific Advisory Board, September 1996.
- Van Keuren, E. and Knighten, Dr. J.. "Implications of the High Power Microwave Weapons Threat in Electronic Systems Design." IEEE International Symposium on Electromagnetic Compatibility, Hyatt Cherry Hill, Cherry Hill, New Jersey, 12-16 August, 1991.
- Van Keuren, E. and Knighten, Dr. J.. "Use of High Power Microwave Weapons." Proceedings, the Institute of Electrical and Electronics Engineers 29<sup>th</sup> Annual 1995 International Carnahan Conference on Security Technology, Sanderstead, Surrey, England, 18-20 October 1995.
- Wall, Robert. "Directed-Energy Arms Sought by China." Aviation Week and Space Technology, Vol 149, Issue 19 (9 November 1998), p. 35.
- Walling, Colonel Eileen M., (USAF). High Power Microwaves: Strategic and Operational Implications for Warfare. Occasional Paper No 11. Maxwell AFB, AL: Center for Strategy and Technology, Air War College, November 1999. Forthcoming.
- Washington Post, 20 September 1999.
- Zhihao, Zhu. Trends of Microwave Weapon Development. Translated by Edward A. Suter. WPAFB, OH: National Air Intelligence Center, 4 January 1996.