

SPECIFICATIONS

GENERAL

Aluminum framing shall be Marlin System 40 as manufactured by Marlin windows.

MATERIALS

All supporting members shall be aluminum extrusions of 6063-T5 alloy & temper with a minimum wall thickness of .094". Glazing stops shall have a minimum wall thickness of .062".

FINISH

Standard architectural Class II anodic color conforming to Aluminum Association AA-M12-C22-A34 for dark bronze or AA-M12-C22-A31 for clear anodize. (Architectural Class I and Class II anodic finishes and organic coatings available - specify).

CONSTRUCTION

Aluminum framing shall have a 1 3/4" face width and a depth of 4 1/2". The vertical and horizontal members shall be joined by screw spline or through a shear clip attached to the vertical member.

PERFORMANCE

System 40 shall be tested in accordance with AAMA 501 and meet the requirements of ASTM E 331 for water penetration, and ASTM E 330 for structural performance. Deflection of mullions shall be limited to L/175 when subjected to the project design pressure of ____ P.S.F. (Architect to specify).

GLAZING

System 40 shall accommodate 3/16" or 1/4" glazing.

INSTALLATION

Glass and framing shall be installed straight, plumb, and level without twisting and securely anchored in place. All joints between framing and the building exterior shall be sealed to provide a watertight installation.

PROTECTION AND CLEANING

The General Contractor shall provide adequate protection of the aluminum and glass surfaces from damage by grinding compound, lime, acids, cement or other contaminants. The General Contractor shall be responsible for final cleaning.

1/4 SCALE

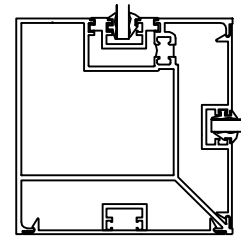
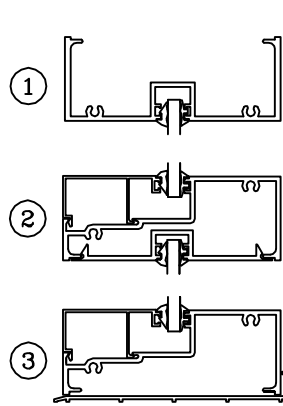
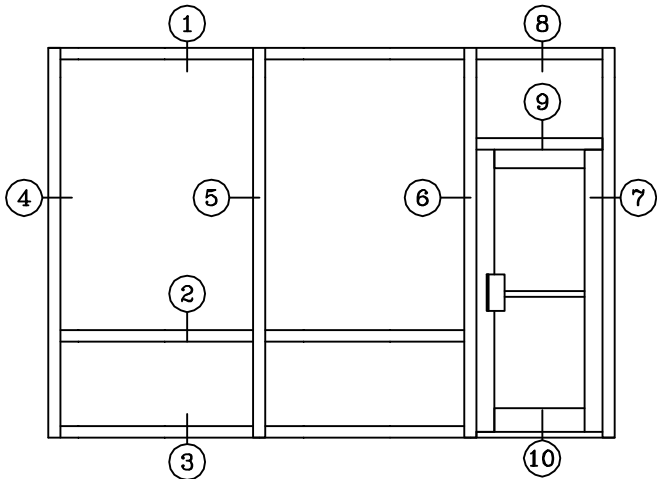

CORNER POST

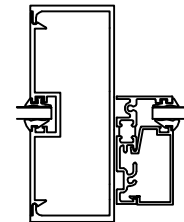

DOUBLE ACTING
TRANSOM

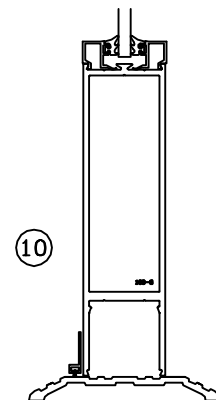
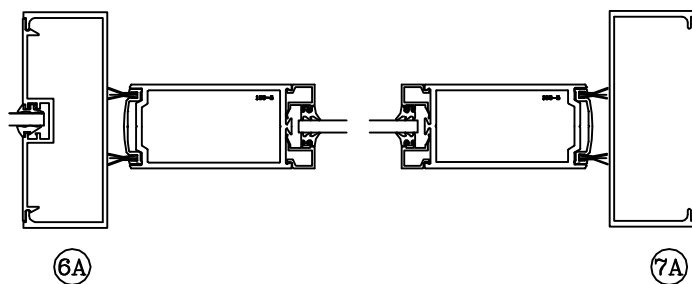
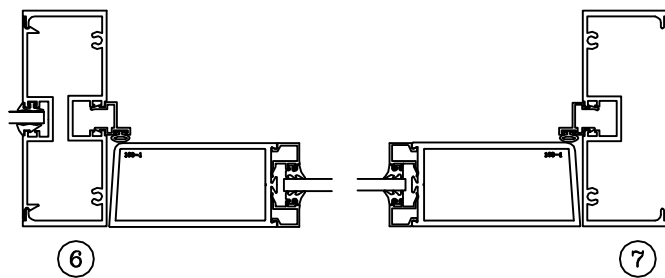
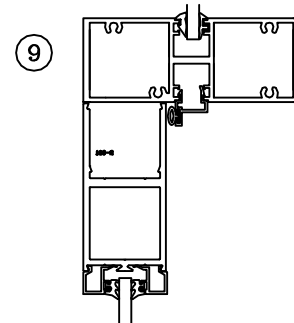
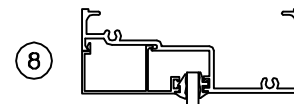
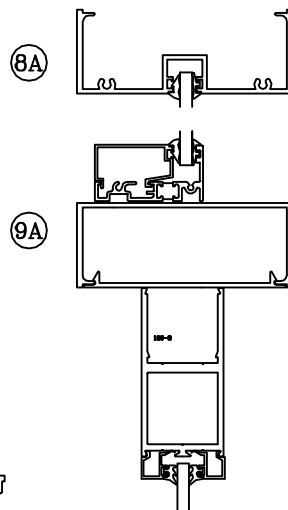
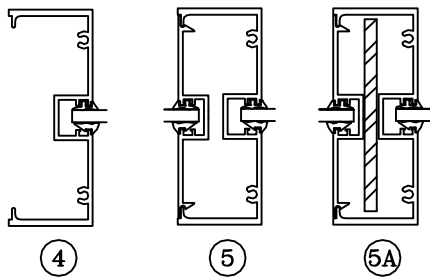

A = 15 PSF
B = 20 PSF
C = 25 PSF
D = 30 PSF

WIND LOAD CHARTS

DEFLECTION LIMITED TO L/175

I = 3.160
S = 1.404

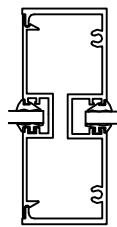
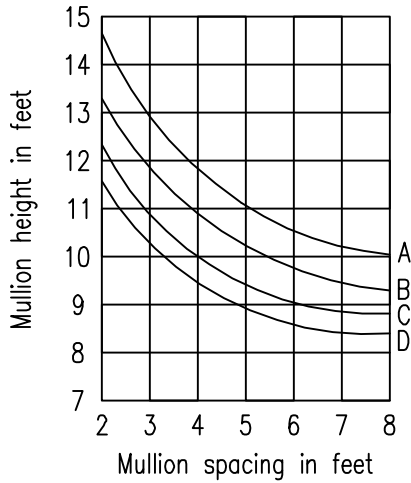

40-182
40-180

I_A = 6.068

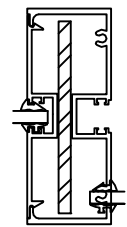
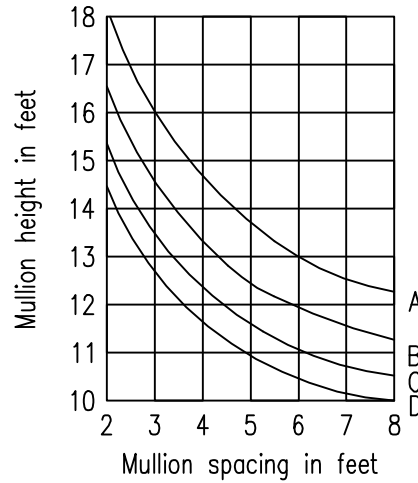

40-182
40-180

DEAD LOAD CHART

1/4 POINT LOADING (A)
1/8 POINT LOADING (B)

I = .273

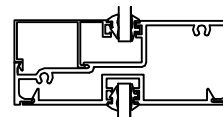
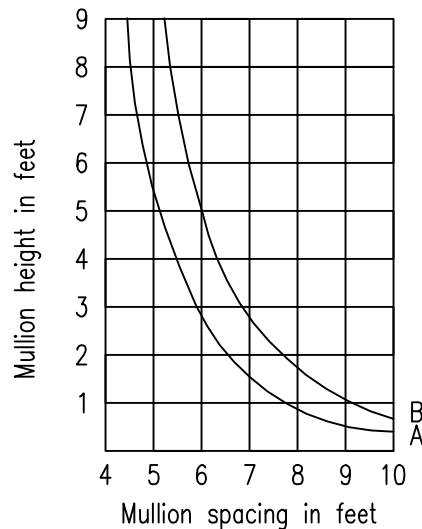

40-183
40-180
40-188

① HEAD

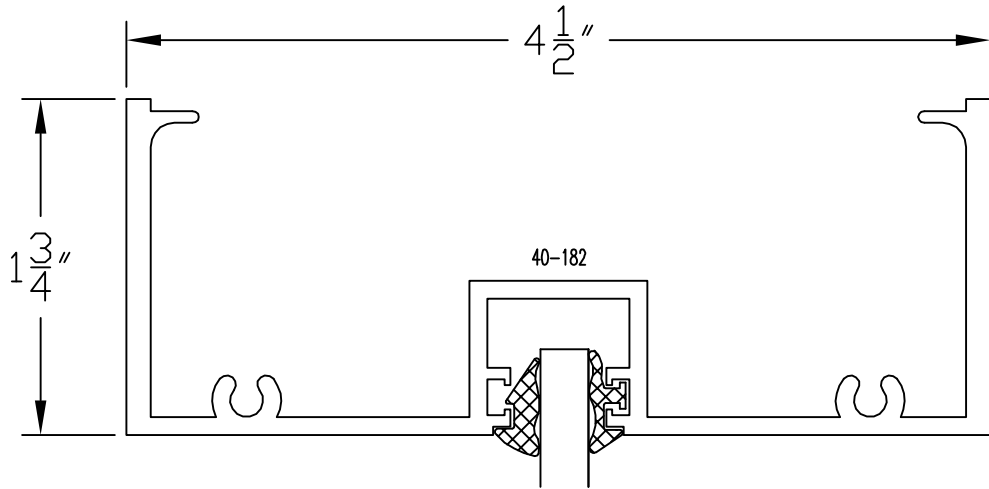

② HORIZONTAL

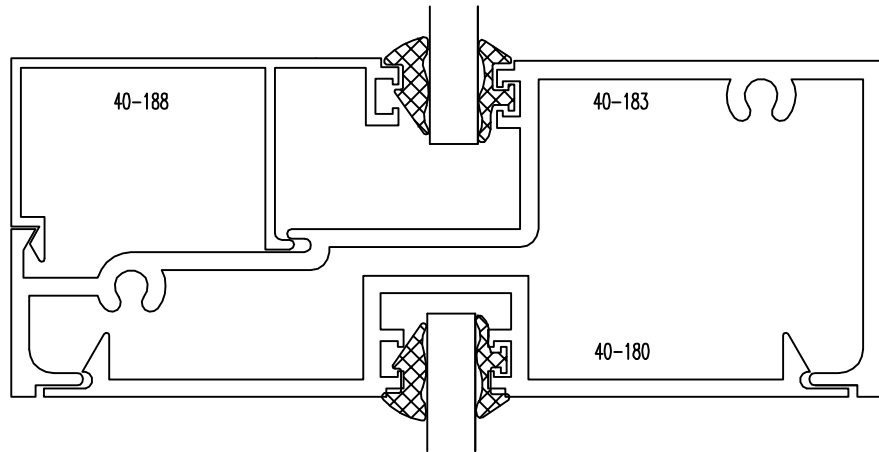

③ SILL

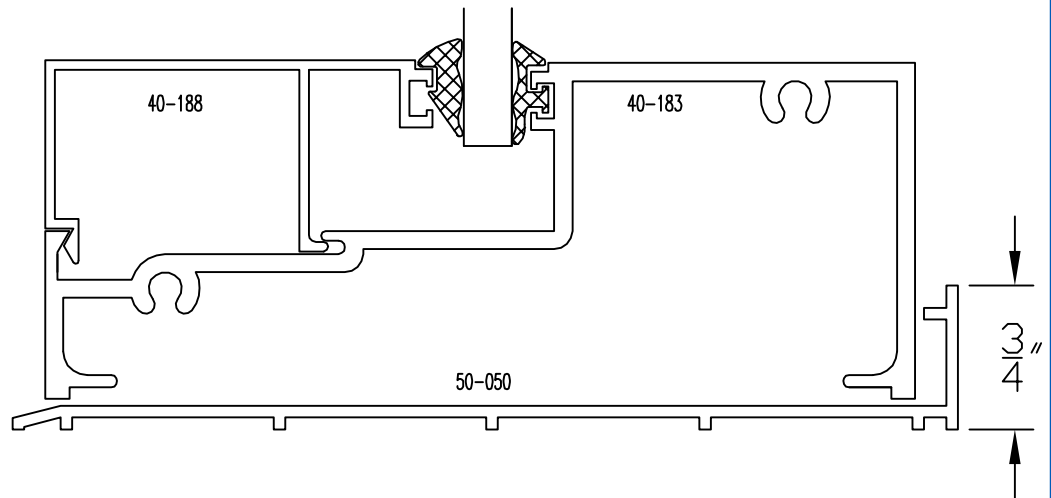

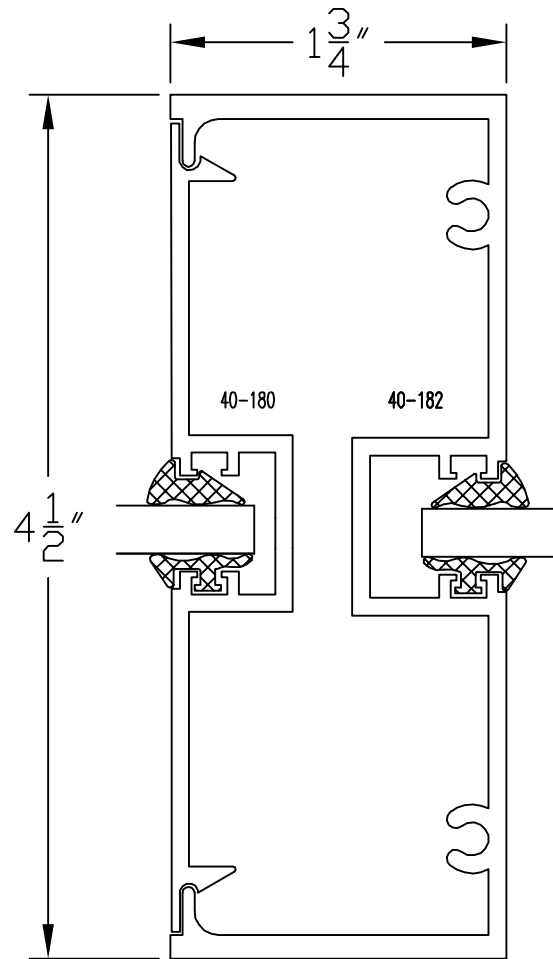

④ JAMB

⑤ MULLION

⑤A MULLION

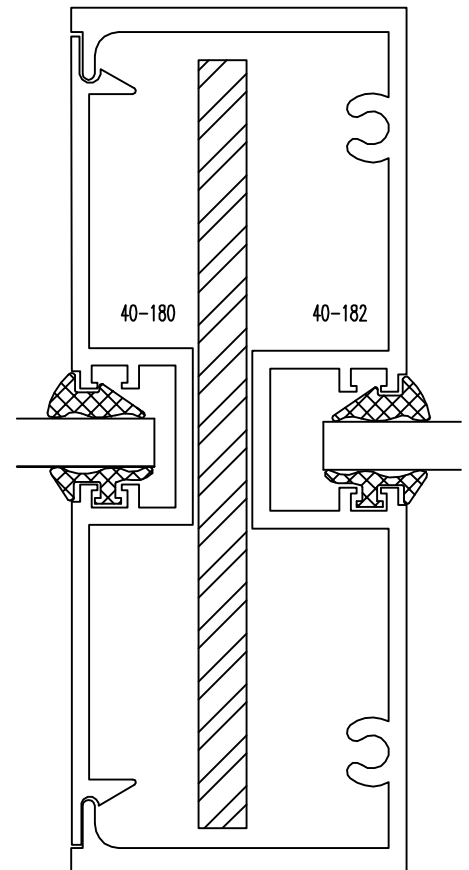
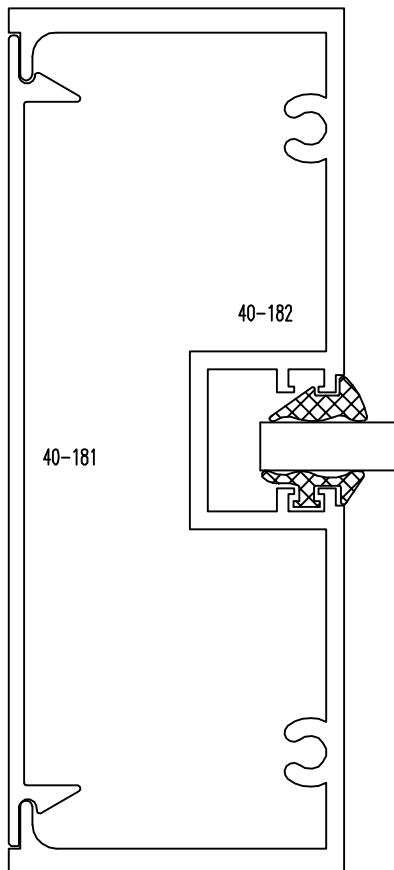

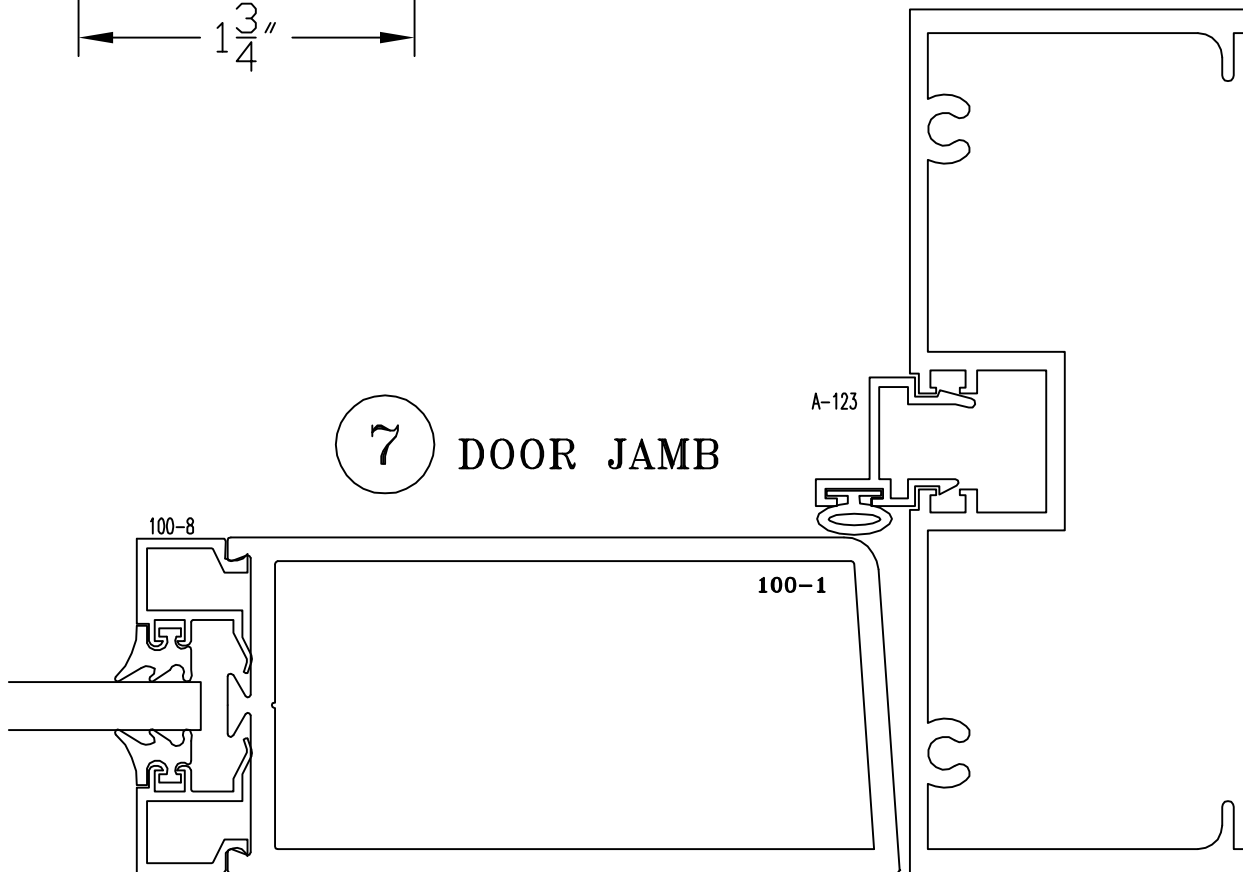
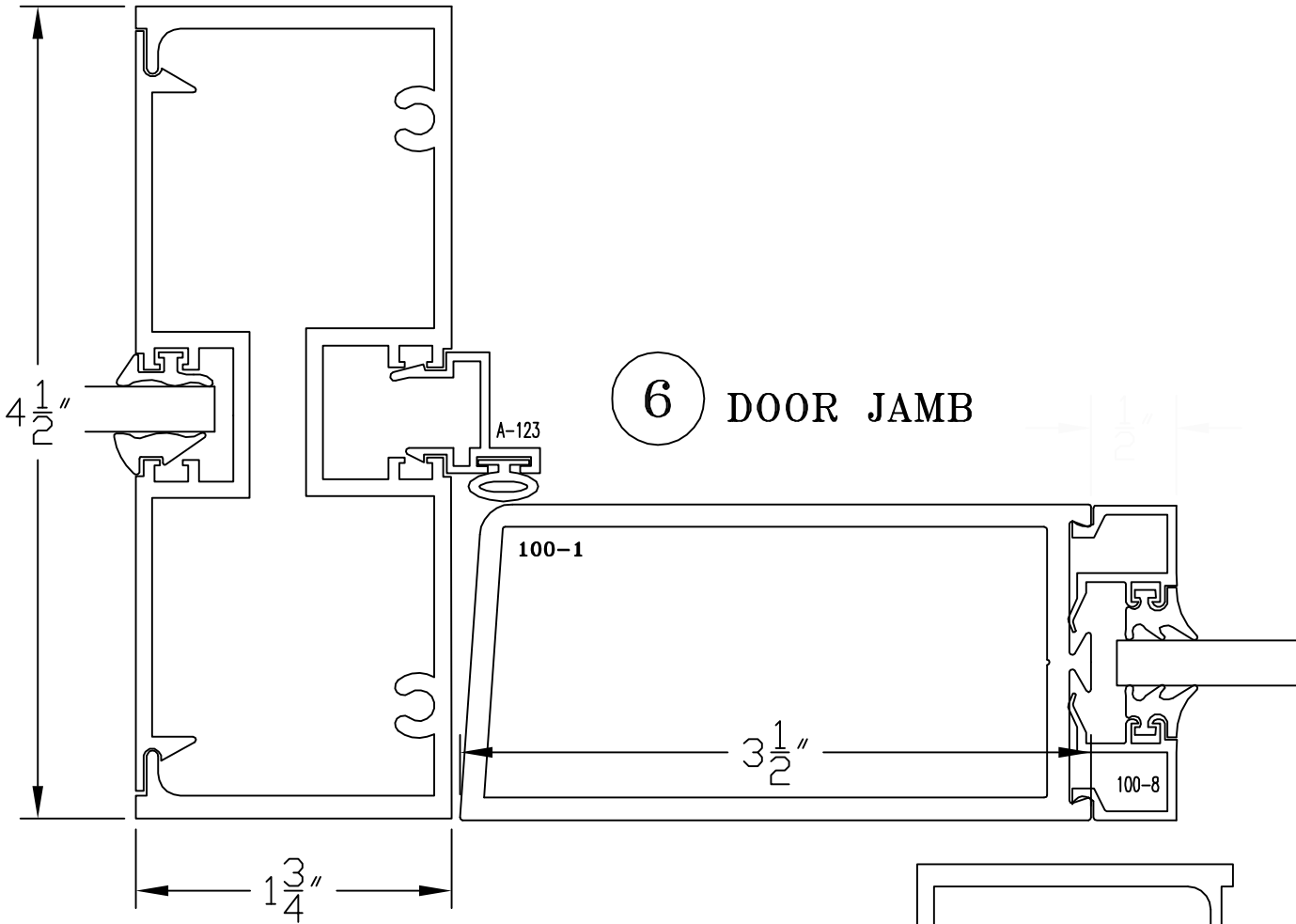

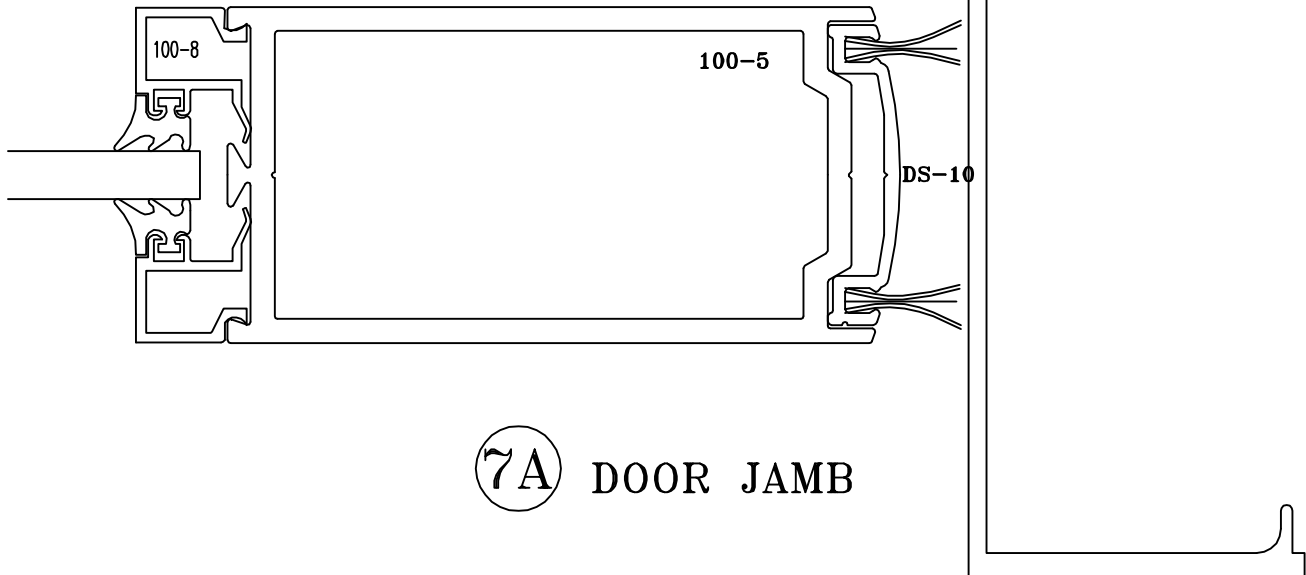
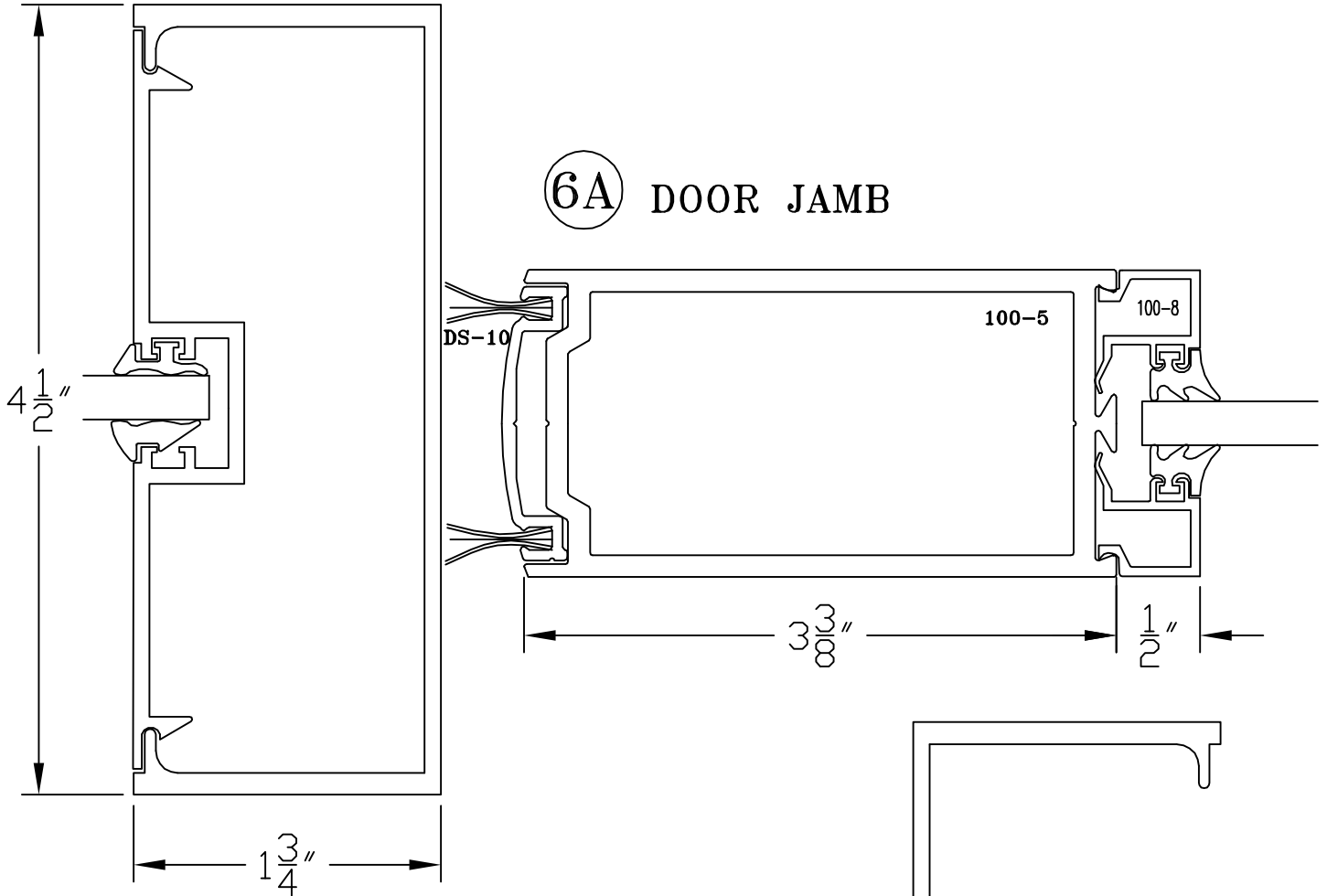

8 HEAD

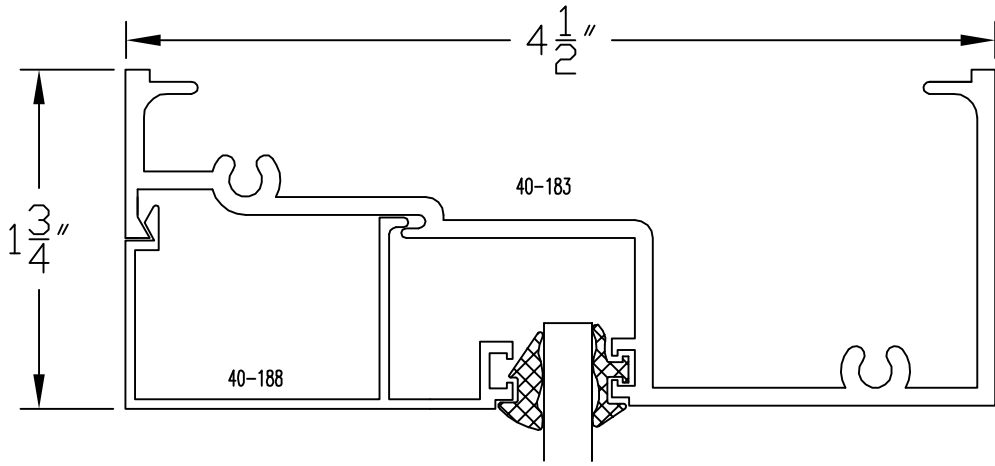

9 DOOR HEAD

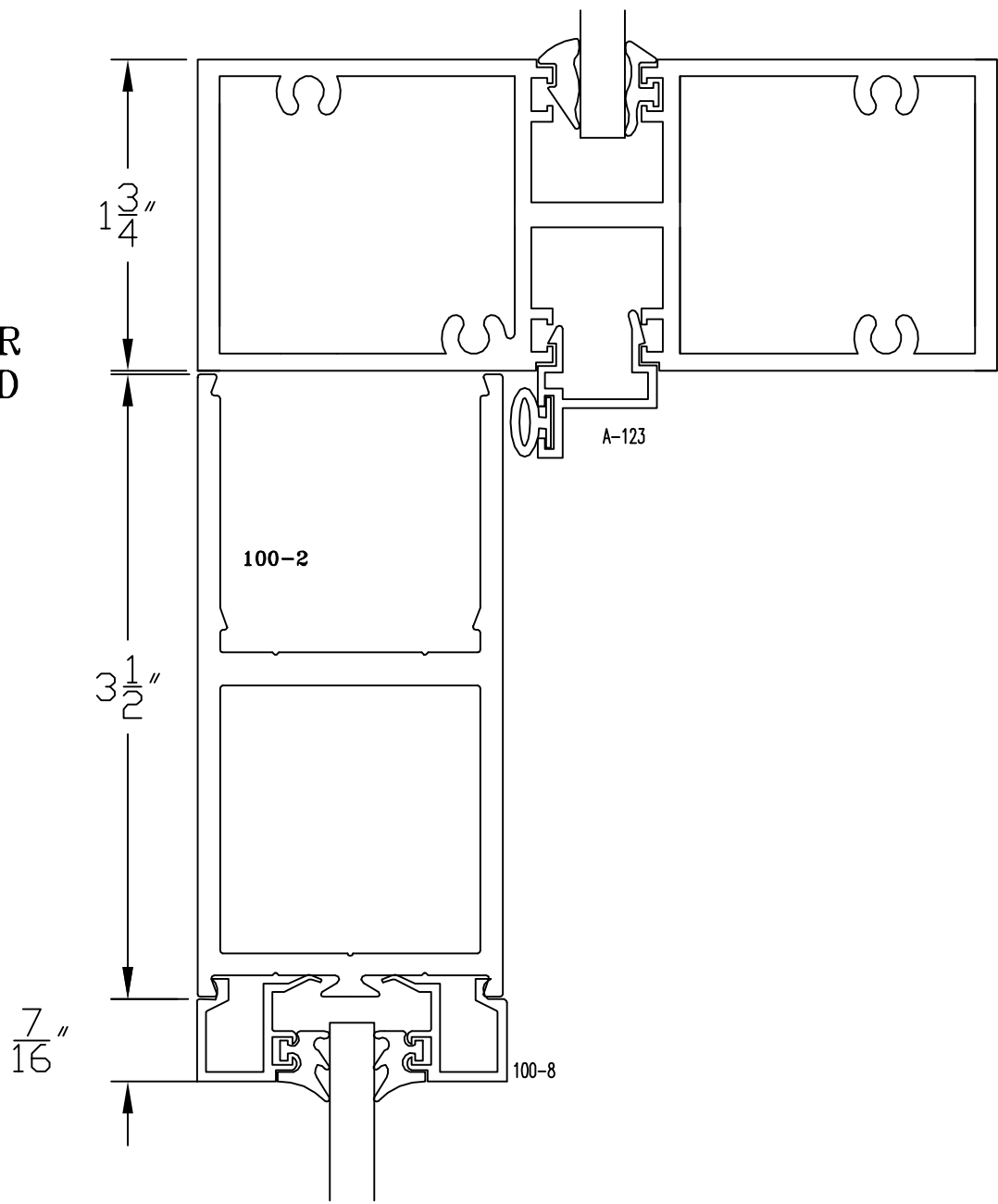

8A HEAD

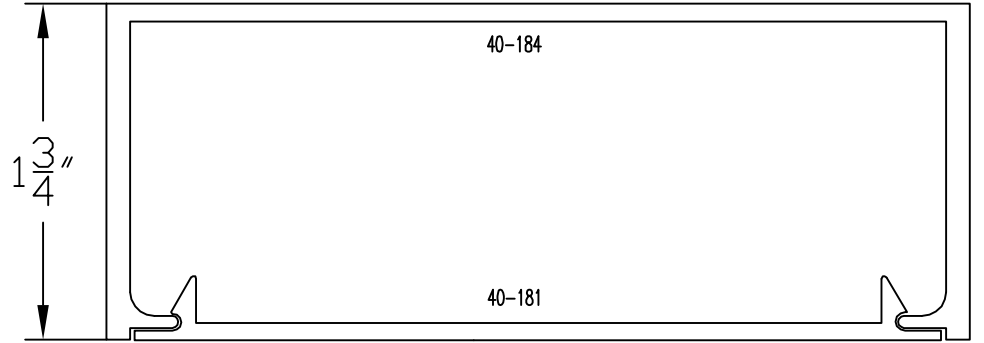
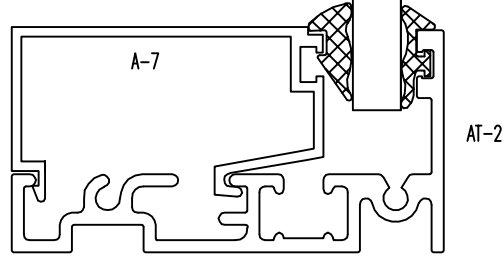
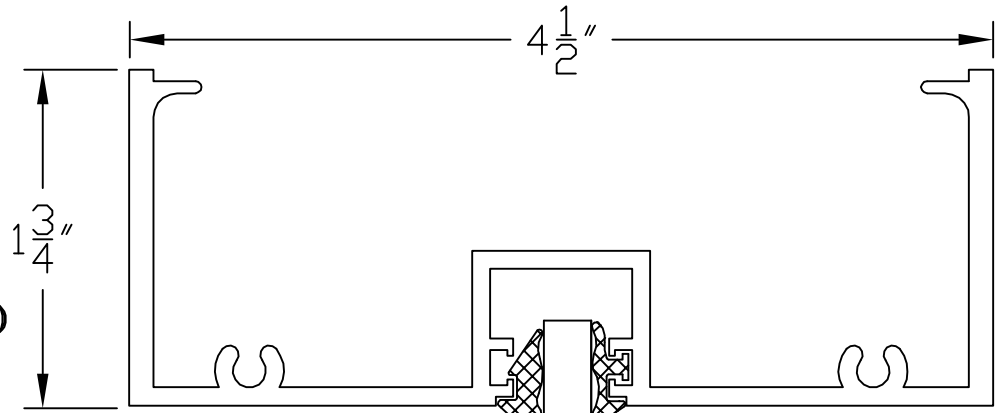

9A DOOR HEAD

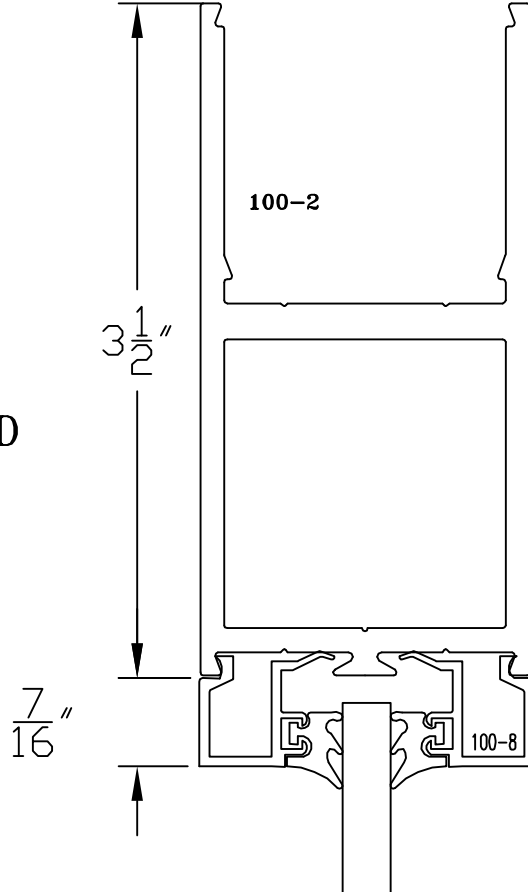

SYSTEM 40 STOREFRONT
1 3/4" x 4 1/2" FRAMING

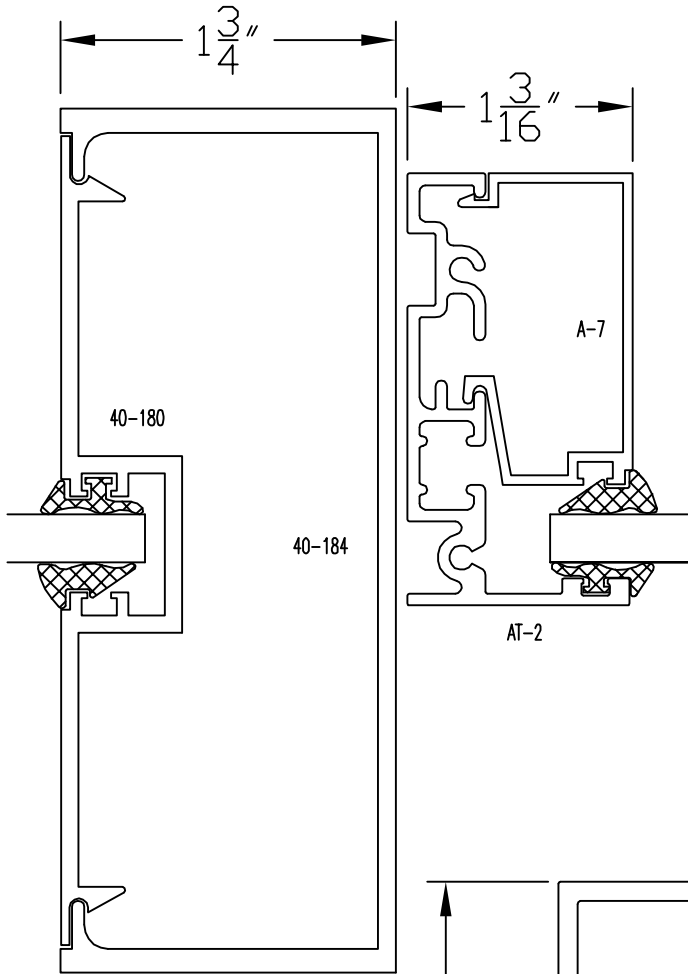

Ⓐ DOUBLE ACTING
TRANSOM

CORNER POST

