

SPECIFICATIONS

GENERAL

Aluminum framing shall be Marlin System 60 thermally improved as manufactured by Marlin windows.

MATERIALS

All framing shall be aluminum extrusions of 6063-T5 alloy & temper with a minimum wall thickness of .094". System 60 shall have a PVC thermal separator to eliminate contact between the interior and exterior sections. Glazing gaskets shall be extruded E.P.D.M. System shall accommodate vertical structural silicone butt glazing (Architect specify).

FINISH

Standard architectural Class II anodic color conforming to Aluminum Association AA-M12-C22-A34 for dark bronze or AA-M12-C22-A31 for clear anodize. (Architectural Class I and Class II anodic finishes and organic coatings available - specify).

CONSTRUCTION

Aluminum framing shall have a 2 1/2" face width and a depth of 7 3/8" or 5 3/4" - (Architect to specify) and provide for flush glazing without projecting stops. Optional low profile vent (Architect to specify) **Maximum vent 60" x 36"**.

OPTIONS

- *Incorporating standard Marlin project-out windows and all glass structural glazed vents.
- *Various beauty cap depths and profiles.
- *Fiber glass pressure plate in lieu of aluminum.
- *Steel reinforcing
- *Standard and custom sunshades.

SEISMIC

System shall be tested to withstand seismic racking without loss of integrity.

PERFORMANCE

System 60 test in accordance with AAMA 501 and meet the requirements of ASTM E 331 for water penetration, and ASTM E 330 for structural performance. Deflection of mullions shall be limited to L/175 when subjected to the project design pressure of ____ P.S.F. (Architect to specify).

System 60 NFRC Simulation test in accordance with ANSI/NFRC 100, Procedure for Determining Fenestration Product U-Factors (2014), ANSI/NFRC 200, Procedure for Determining Fenestration Product Solar Heat Gain Coefficients at Normal Incidence (2014), NFRC 500, Procedure for Determining Fenestration Product Condensation Resistance Values (2014)

GLAZING

Marlin system 60 shall accommodate 1" glazing as required. Provisions for 1/4" glazing shall be accommodated by use of an adapter.

INSTALLATION

Experienced workman in accordance with approved shop drawings shall install system 60. Glass and framing shall be installed straight, plumb, and level without twisting and securely anchored in place. All joints between framing and the building exterior shall be sealed to provide a watertight installation.

PROTECTION AND CLEANING

The General Contractor shall provide adequate protection of the aluminum and glass surfaces from damage by grinding compound, lime, acids, cement or other contaminants. The General Contractor shall be responsible for final cleaning.

1/4 SCALE

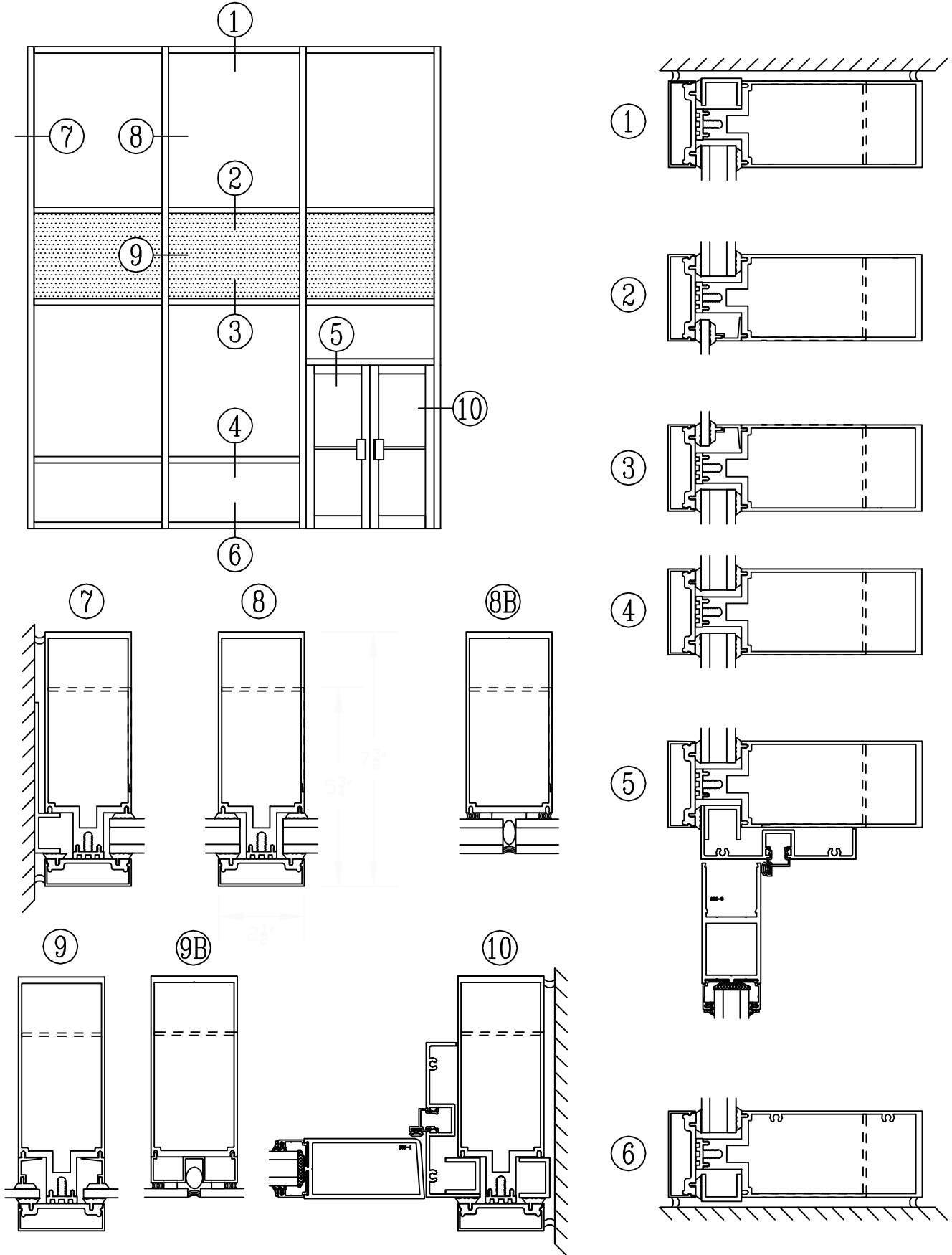

1/4 SCALE

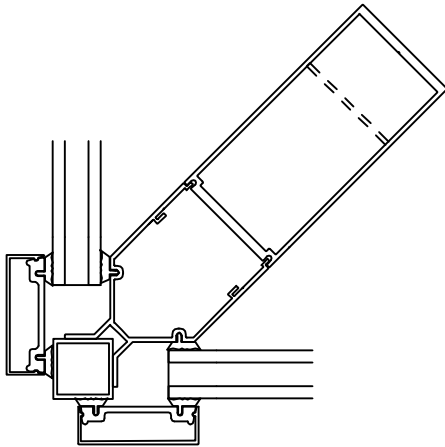

90° OUTSIDE CORNER

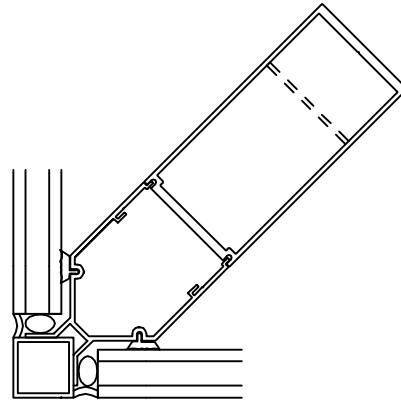

90° OUTSIDE CORNER FOR
BUTT GLAZING

HEAD
COMPENSATING CHANNEL

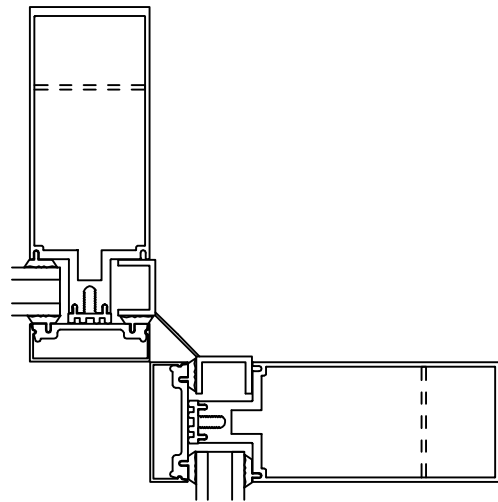
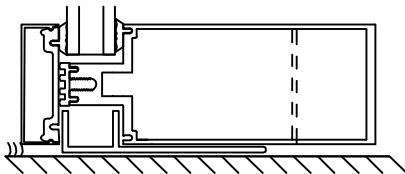
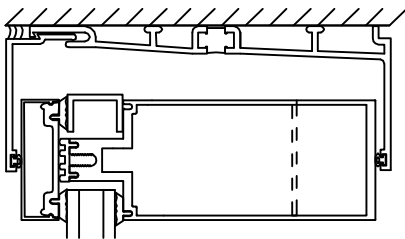

90° INSIDE CORNER

WIND LOAD CHARTS

- A = 15 PSF
- B = 20 PSF
- C = 25 PSF
- D = 30 PSF

DEFLECTION LIMITED TO L/175
16-11 MULLION (2 1/2 X 7 3/8")

I = 12.567
S = 3.711

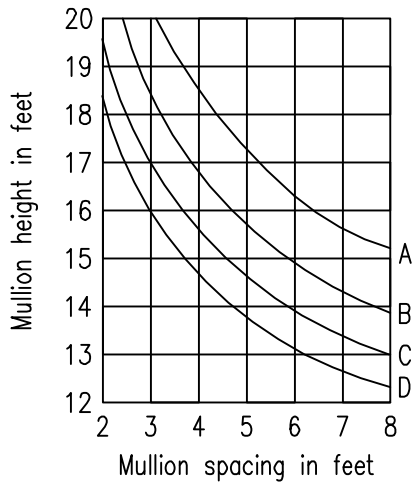

W/ 1/8" STEEL
I_A = 23.075

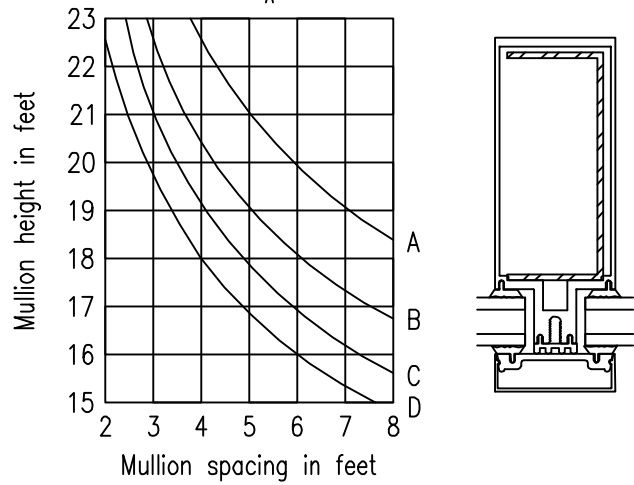

W/ 1/4" STEEL
I_A = 27.407

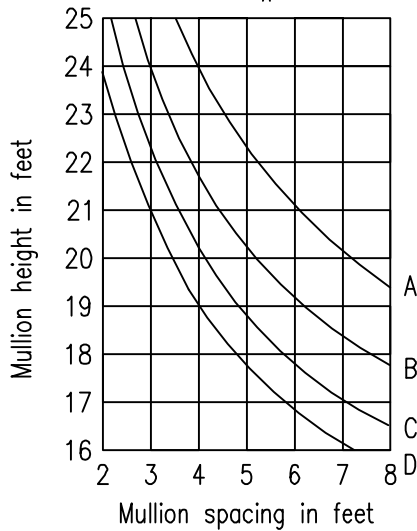

W/ 1/4 + 1/8" STEEL
I_A = 37.915

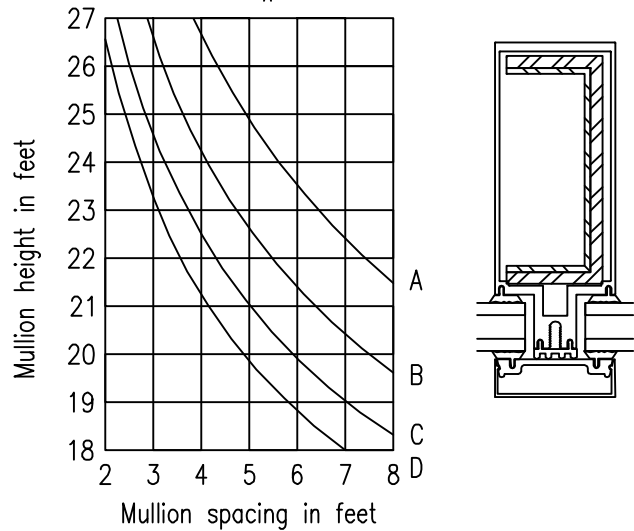

WIND LOAD CHARTS

- A = 15 PSF
- B = 20 PSF
- C = 25 PSF
- D = 30 PSF

DEFLECTION LIMITED TO L/175
16-15 BUTT GLAZE MULLION

$I = 7.839$
 $S = 2.986$

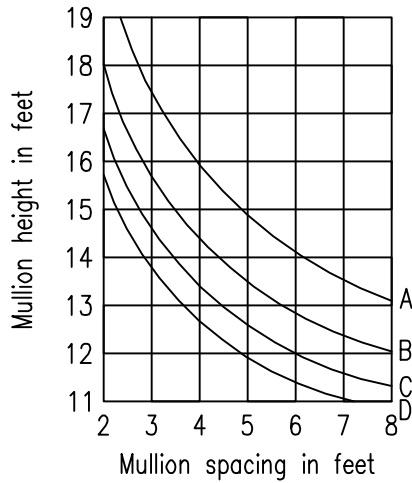

W/ 1/8" STEEL
 $I_A = 18.347$

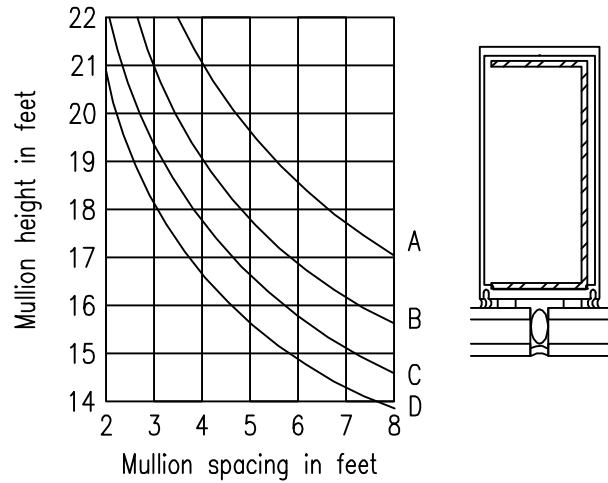

W/ 1/4" STEEL
 $I_A = 22.679$

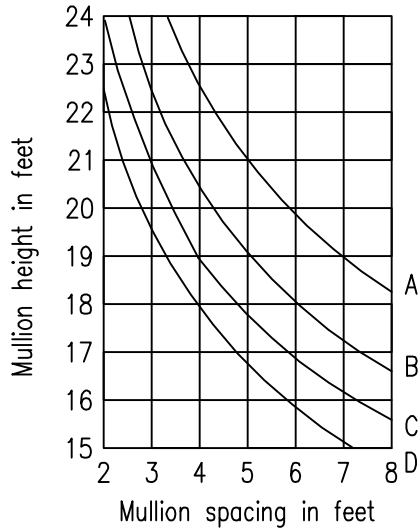

W/ 1/4 + 1/8" STEEL
 $I_A = 33.187$

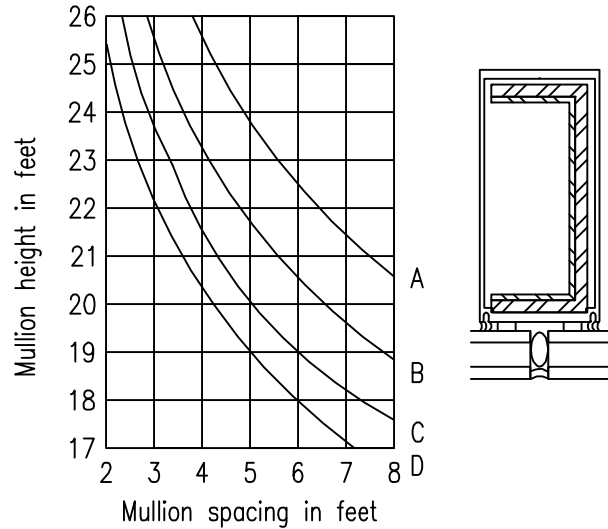

- A = 15 PSF
- B = 20 PSF
- C = 25 PSF
- D = 30 PSF

WIND LOAD CHARTS

DEFLECTION LIMITED TO $L/175$

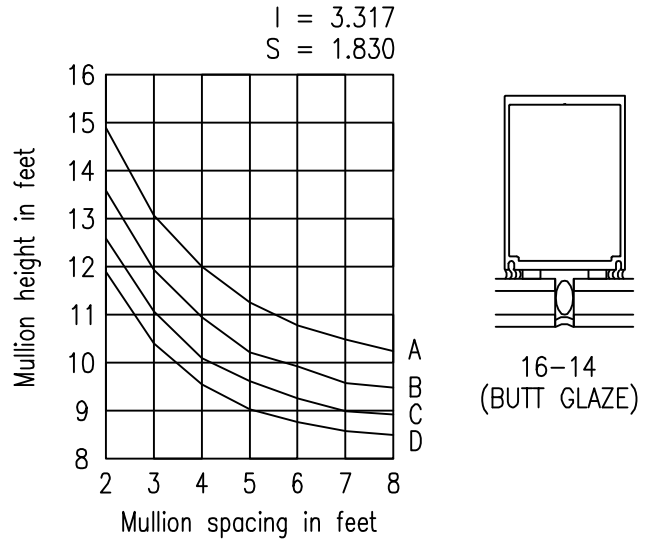
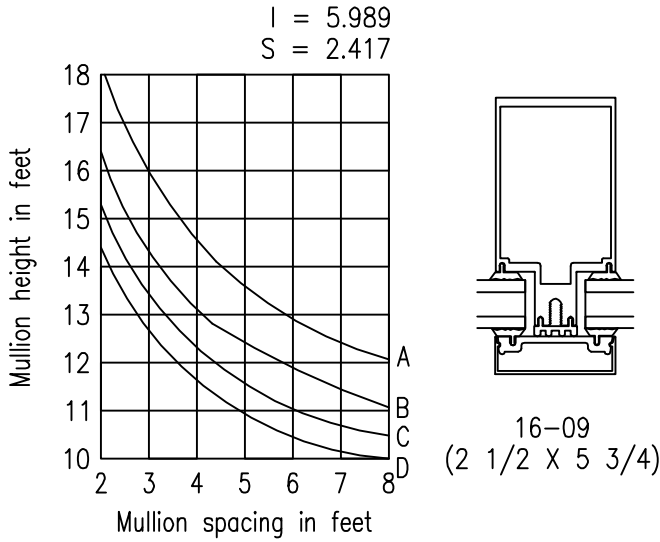

DEAD LOAD CHARTS

- $1/4$ POINT LOADING (A)
- $1/8$ POINT LOADING (B)

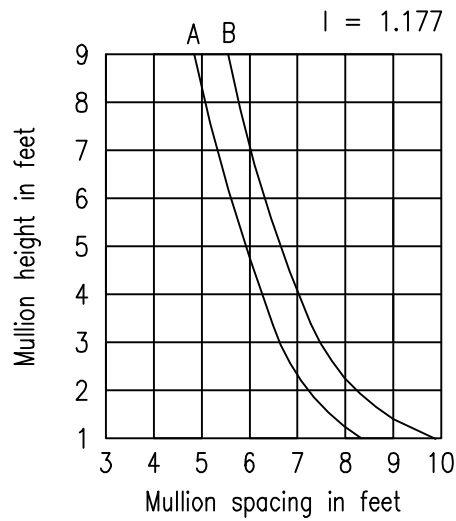
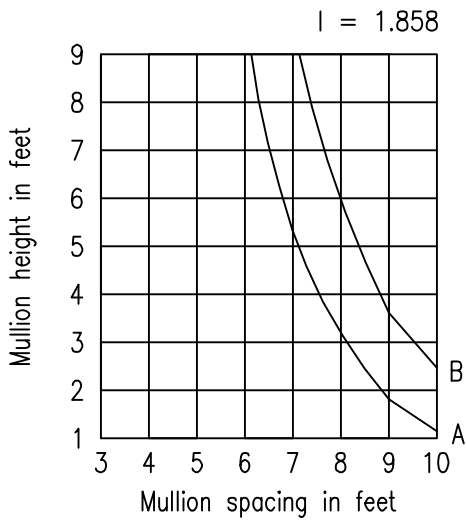

1/4 SCALE

WINDLOAD/DEADLOAD ANCHORING
FOR TWIN SPAN APPLICATIONS

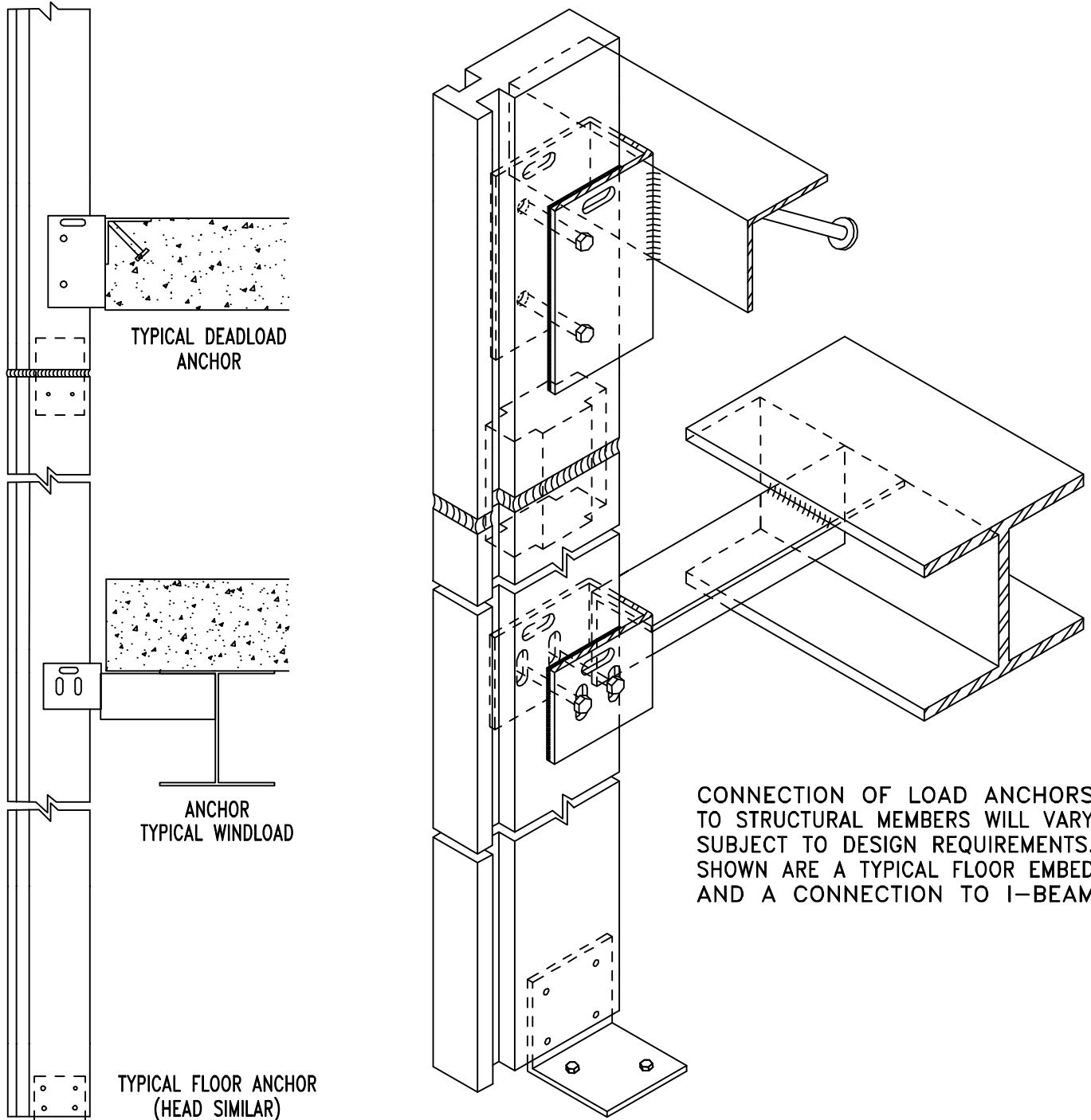

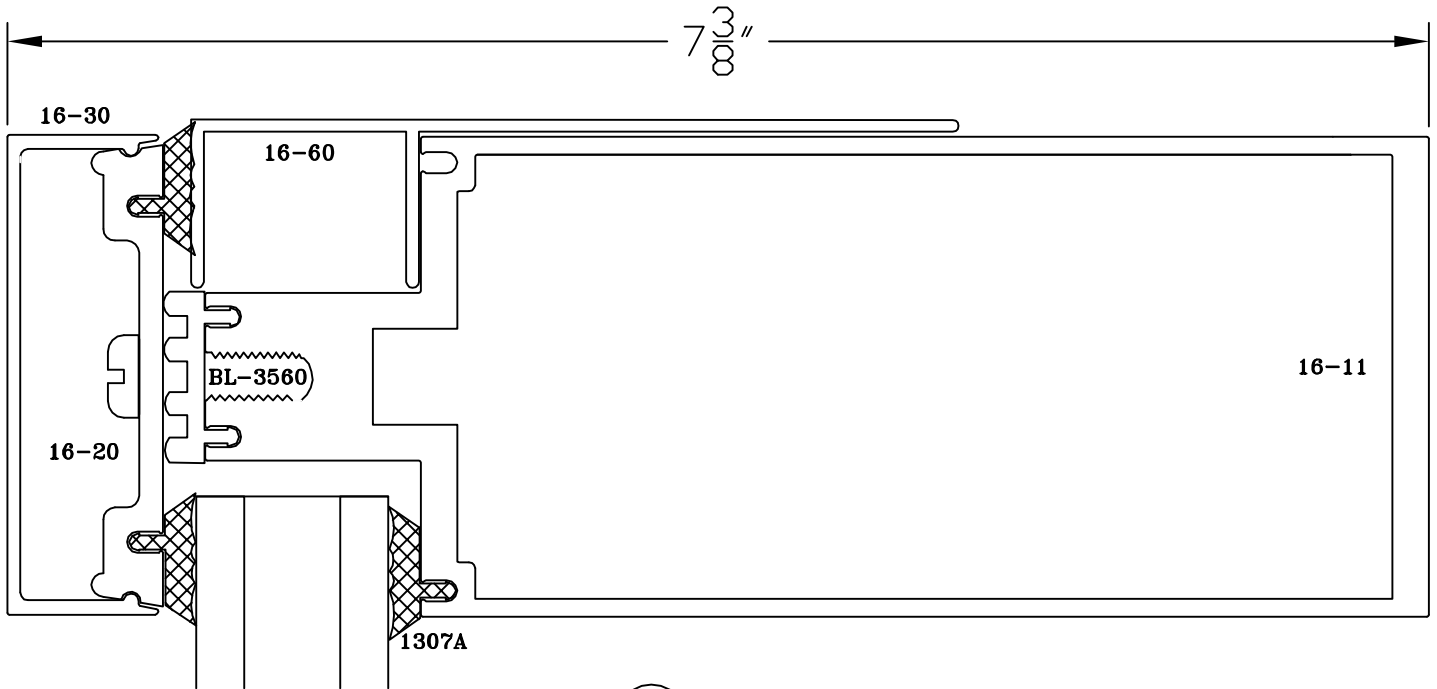

① HEAD

①A HEAD

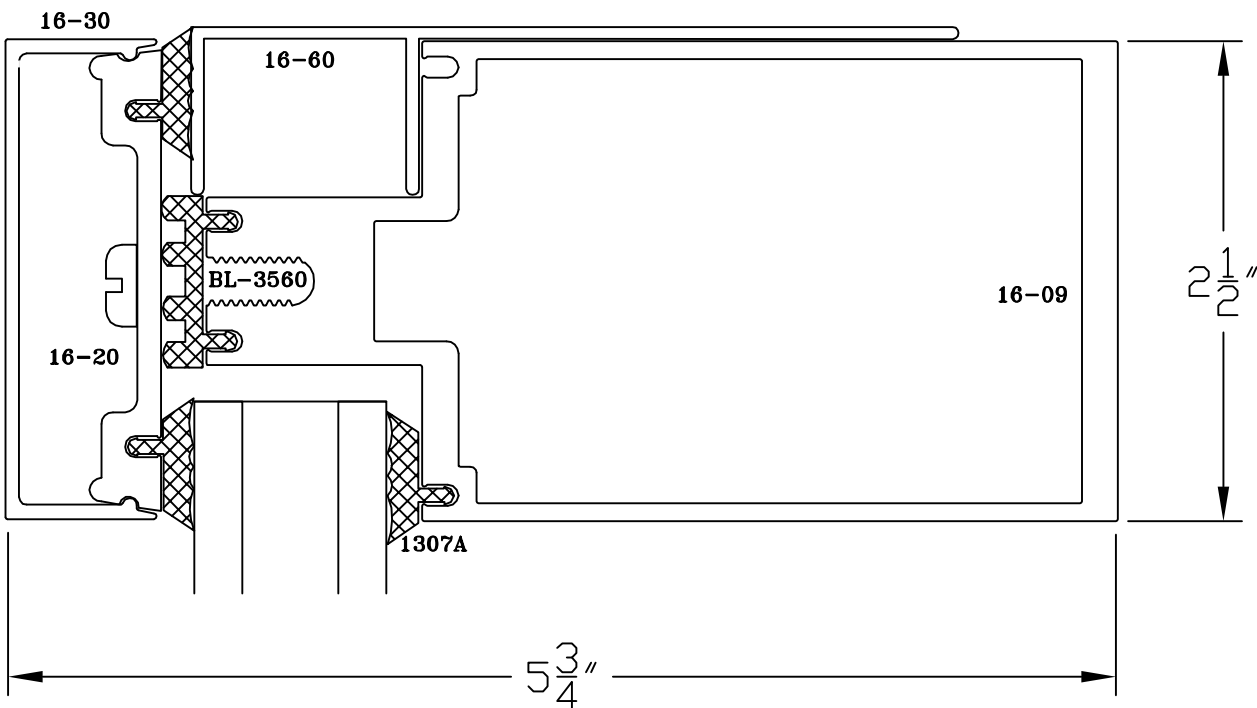

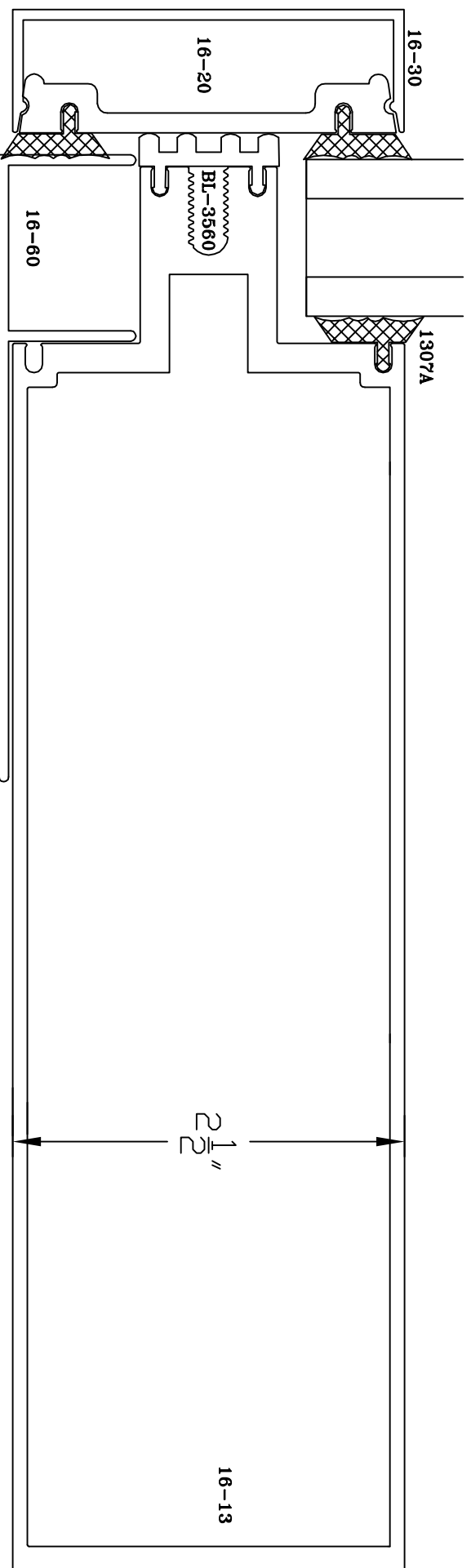
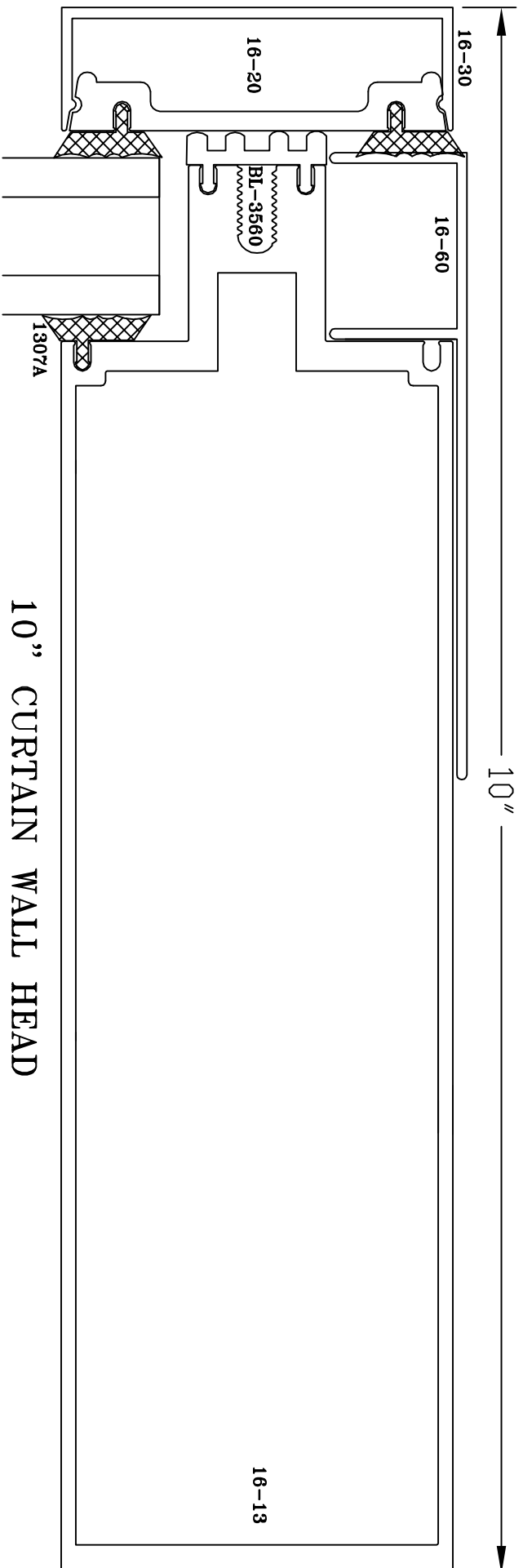

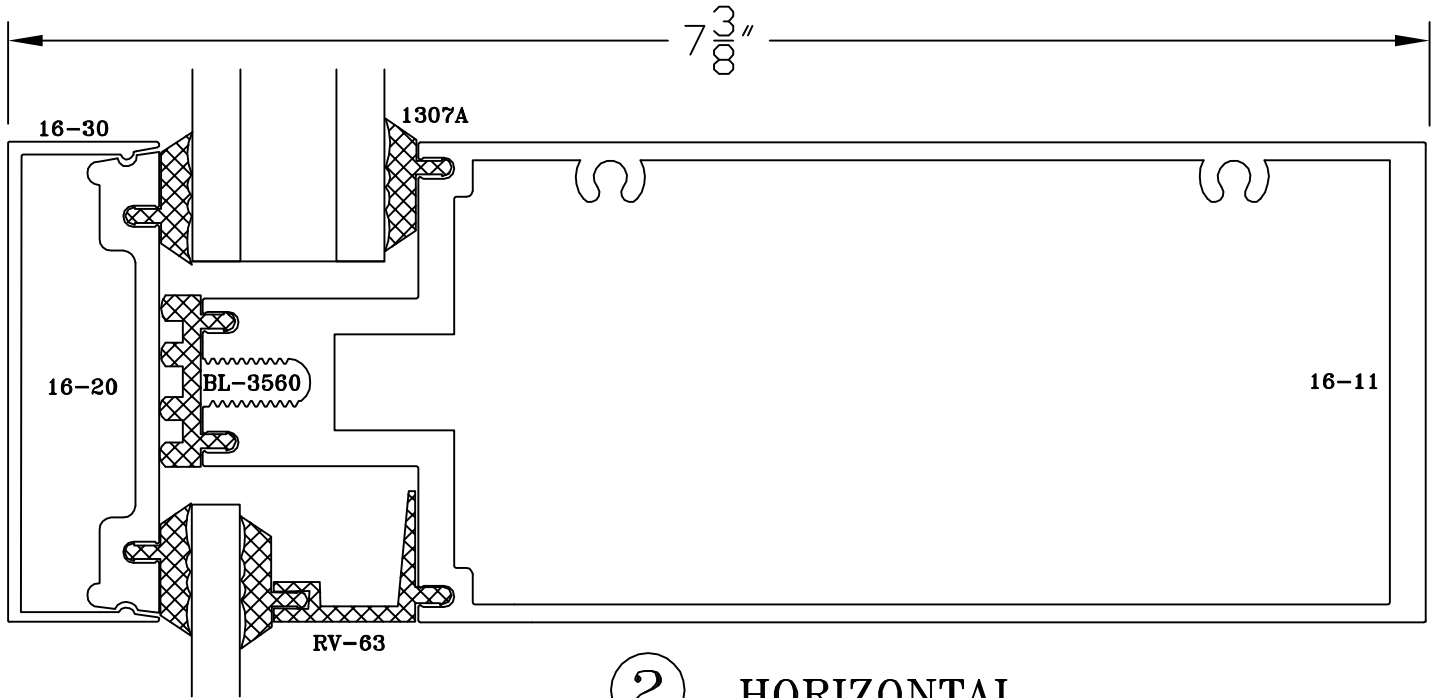

② HORIZONTAL

②A HORIZONTAL

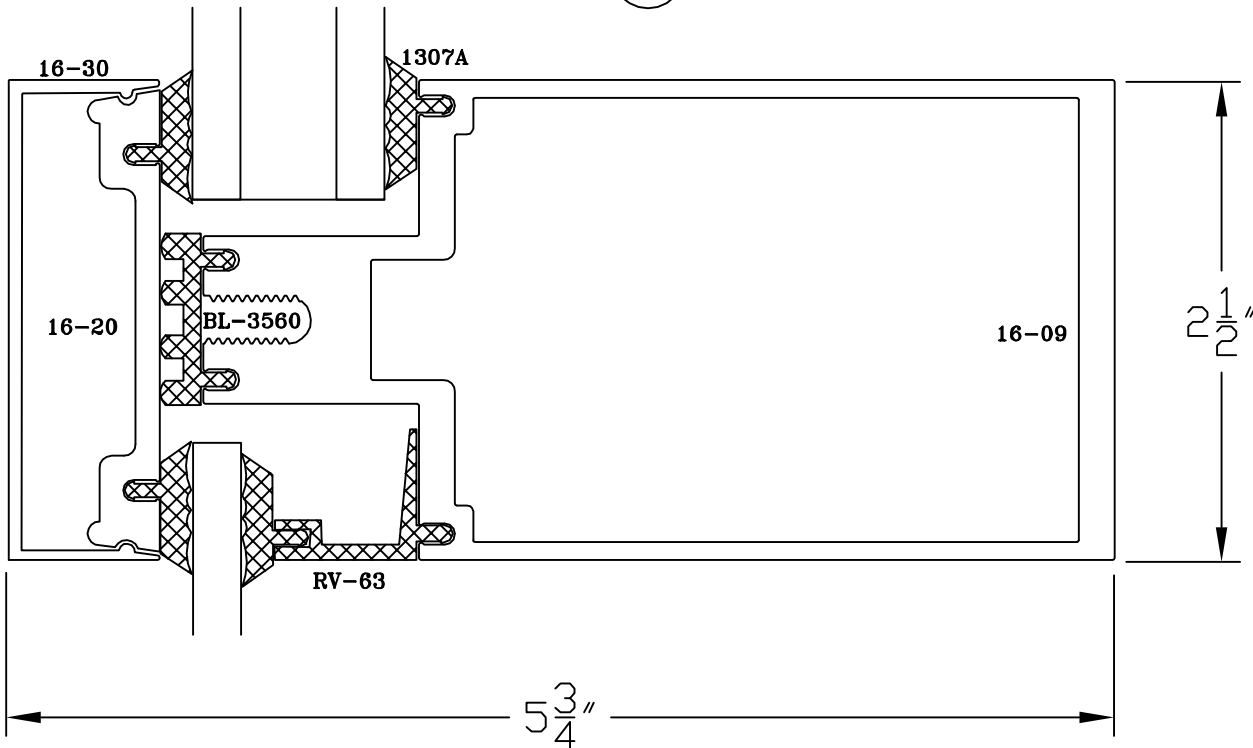

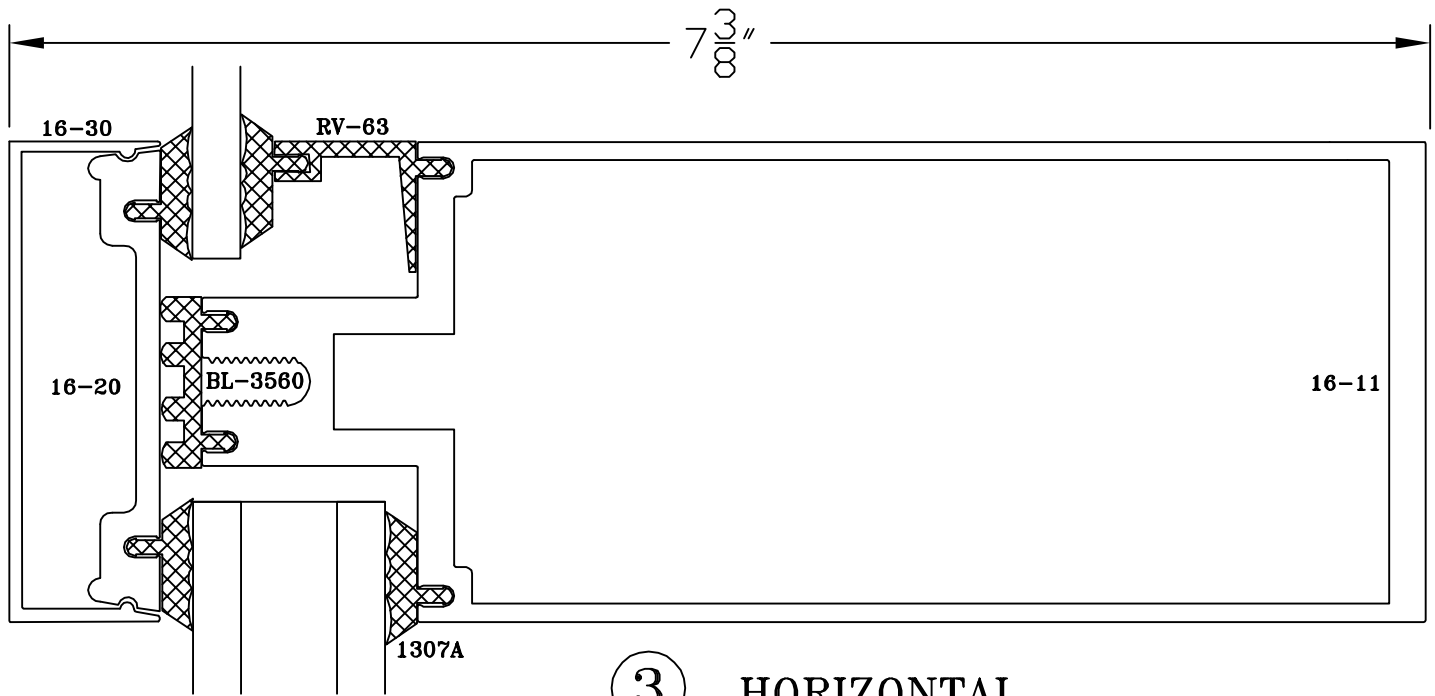

3 HORIZONTAL

3A HORIZONTAL

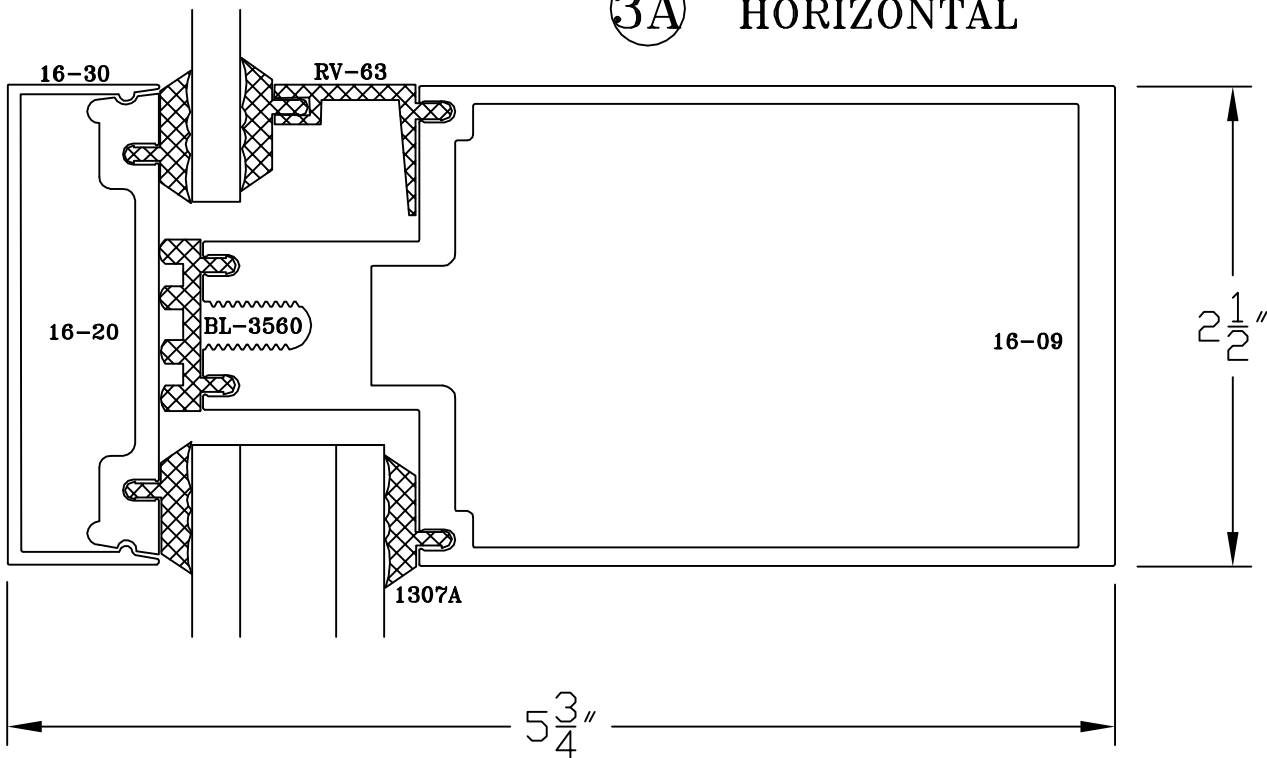

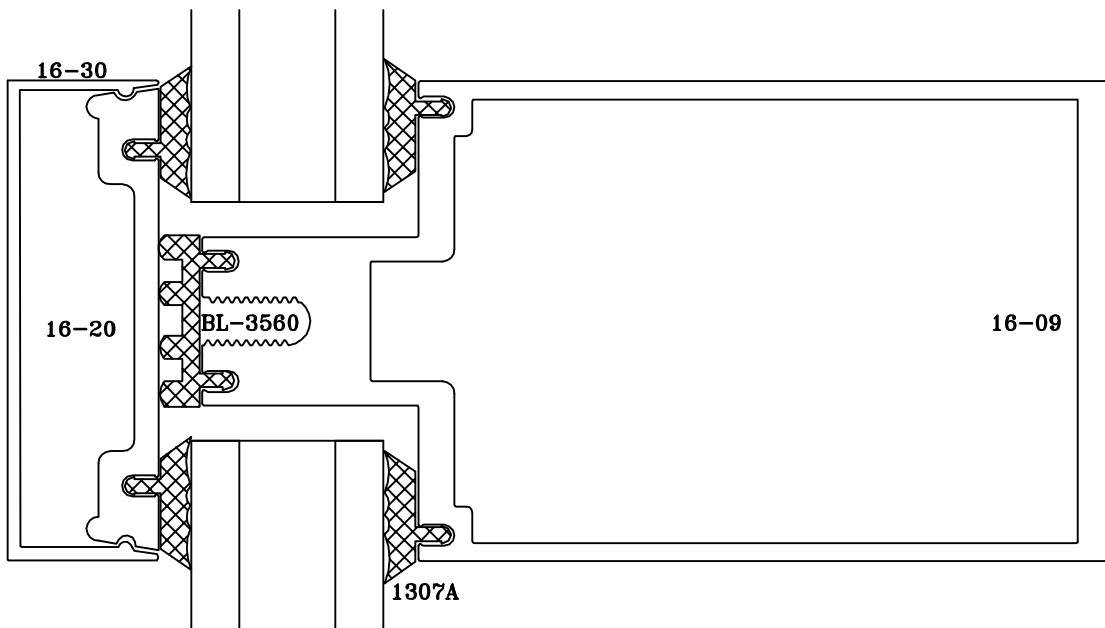
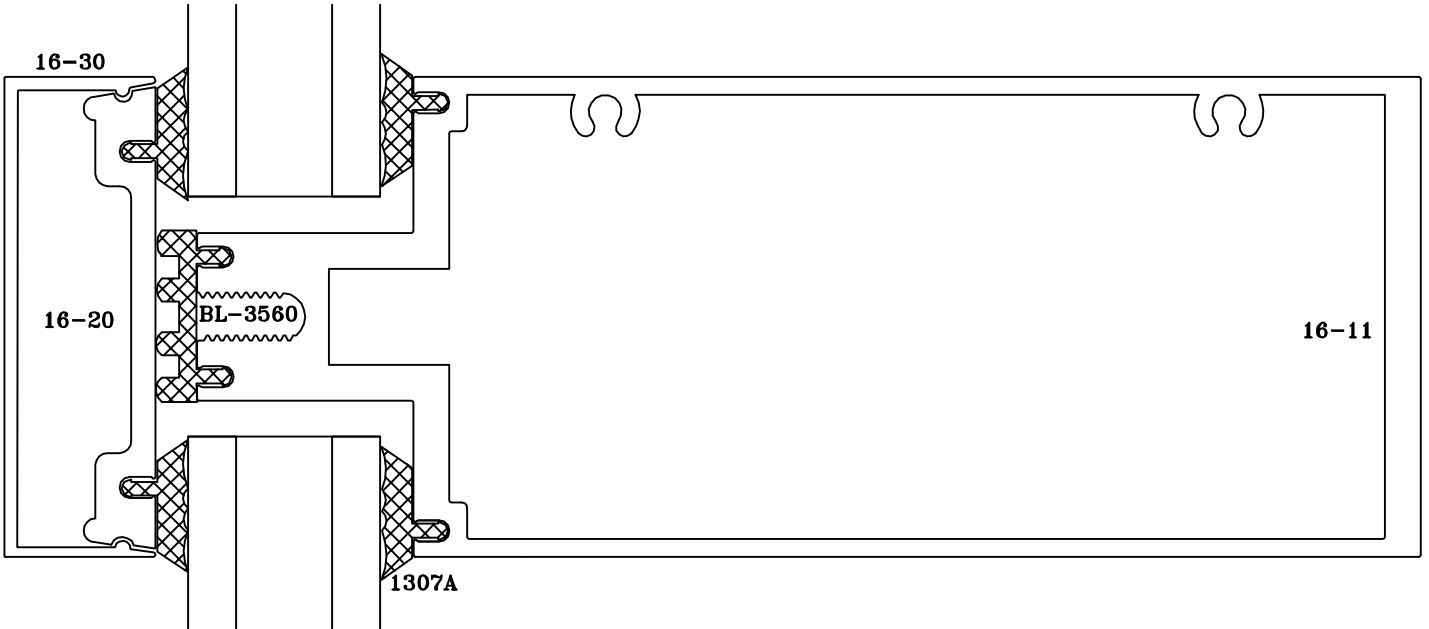

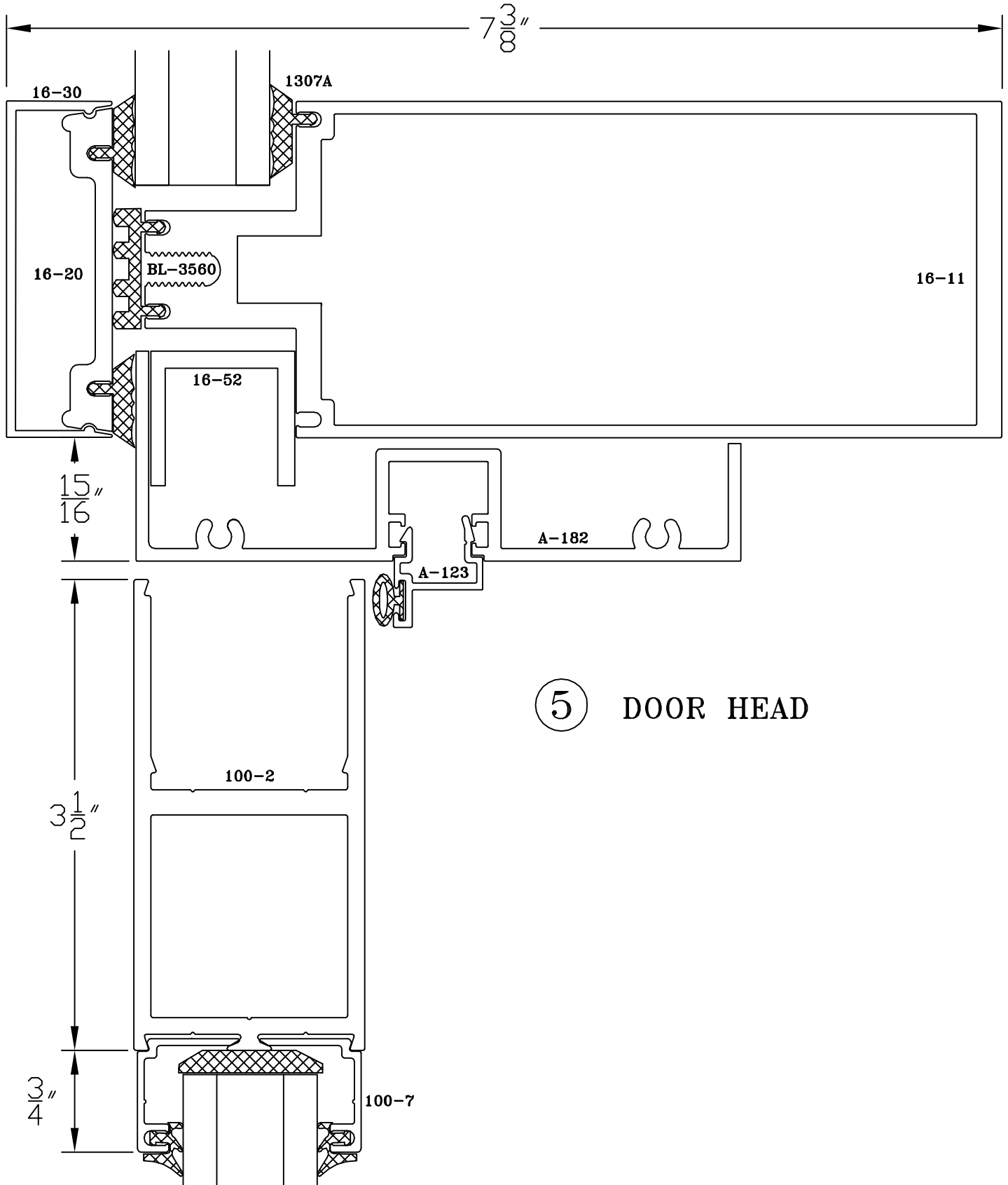

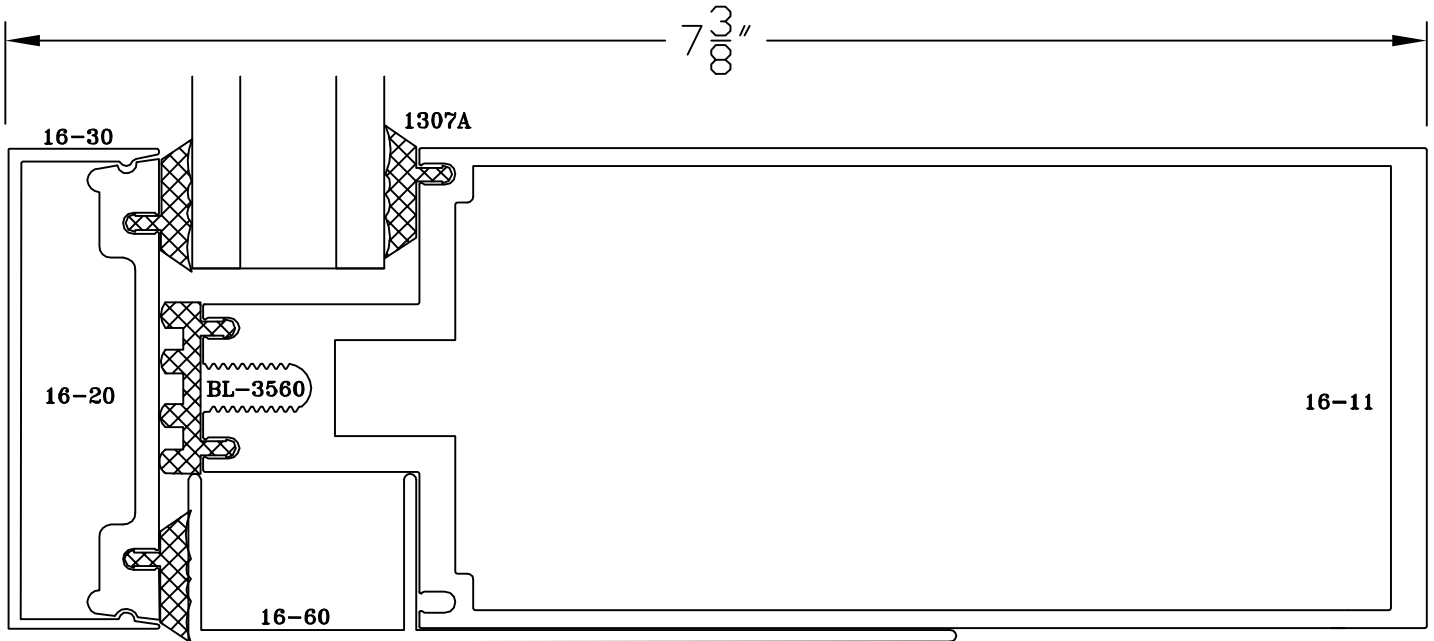

⑥ SILL

⑥A SILL

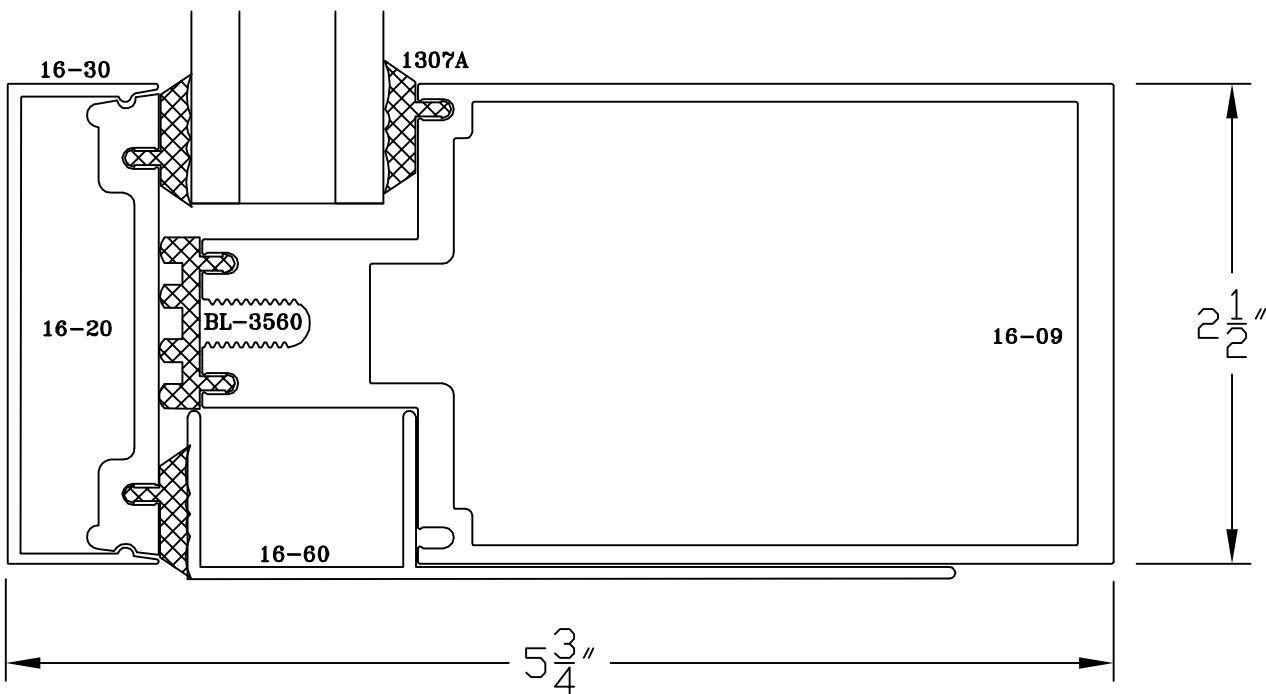

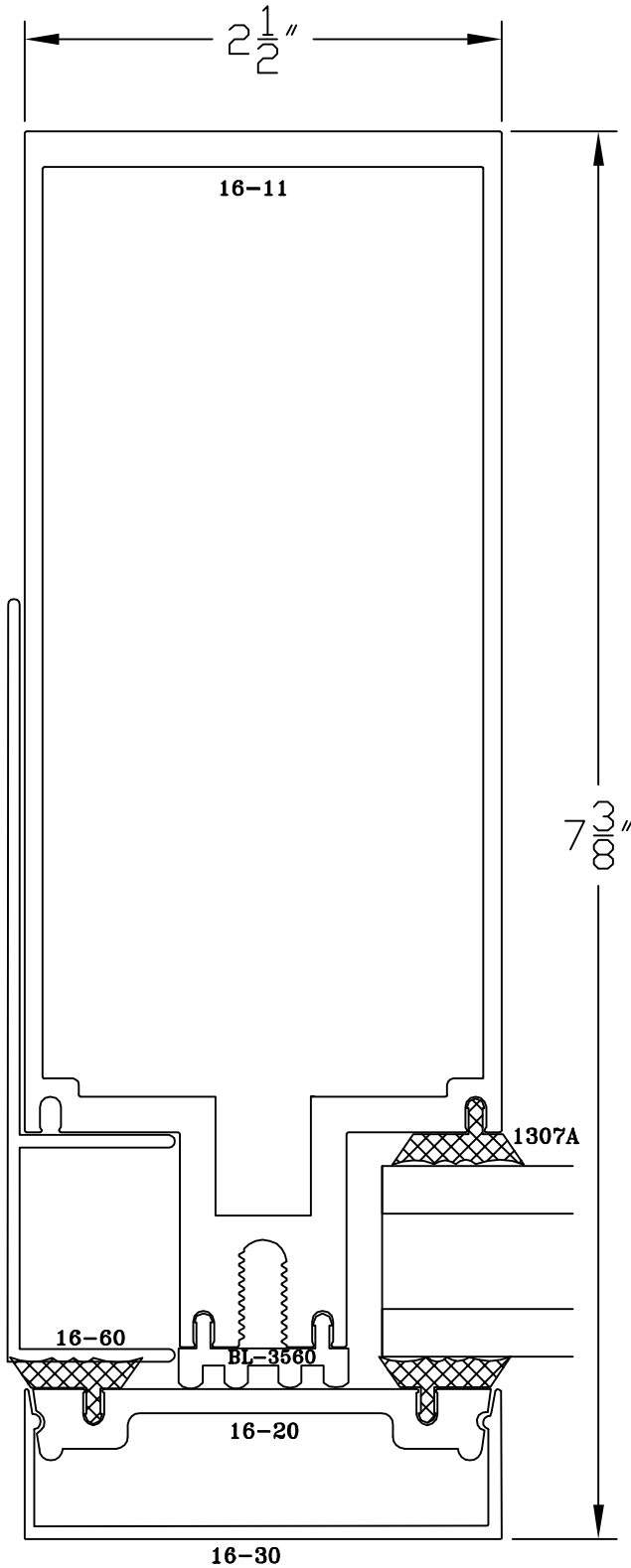

⑦ JAMB

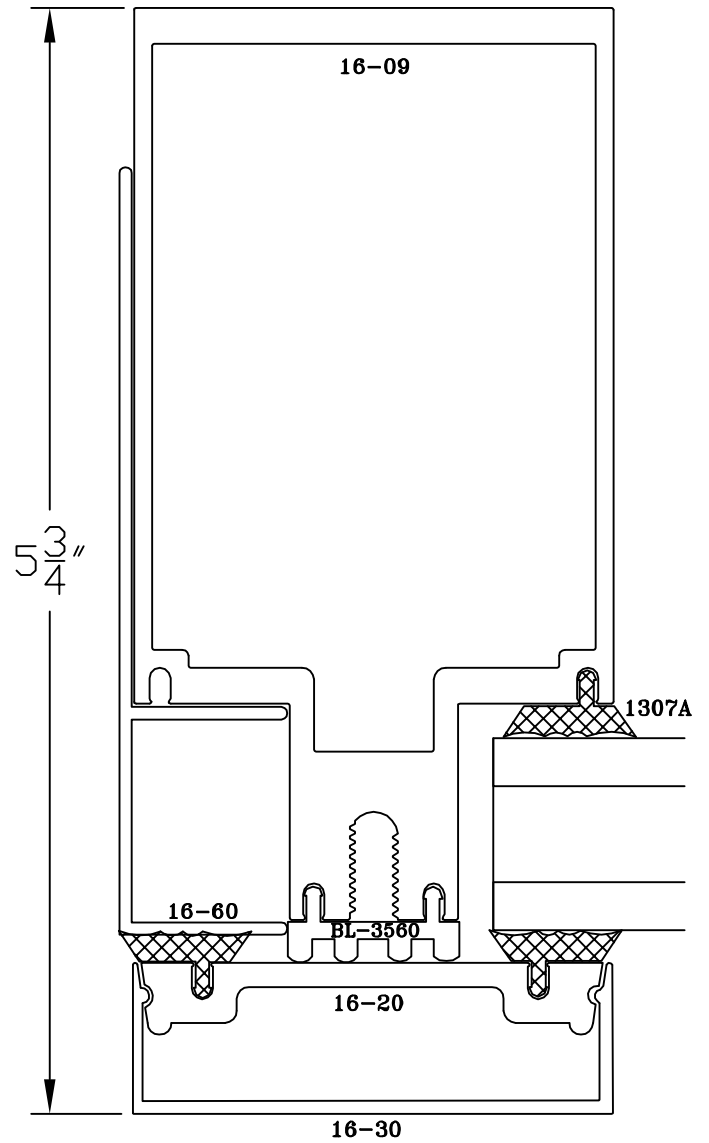

⑦A JAMB

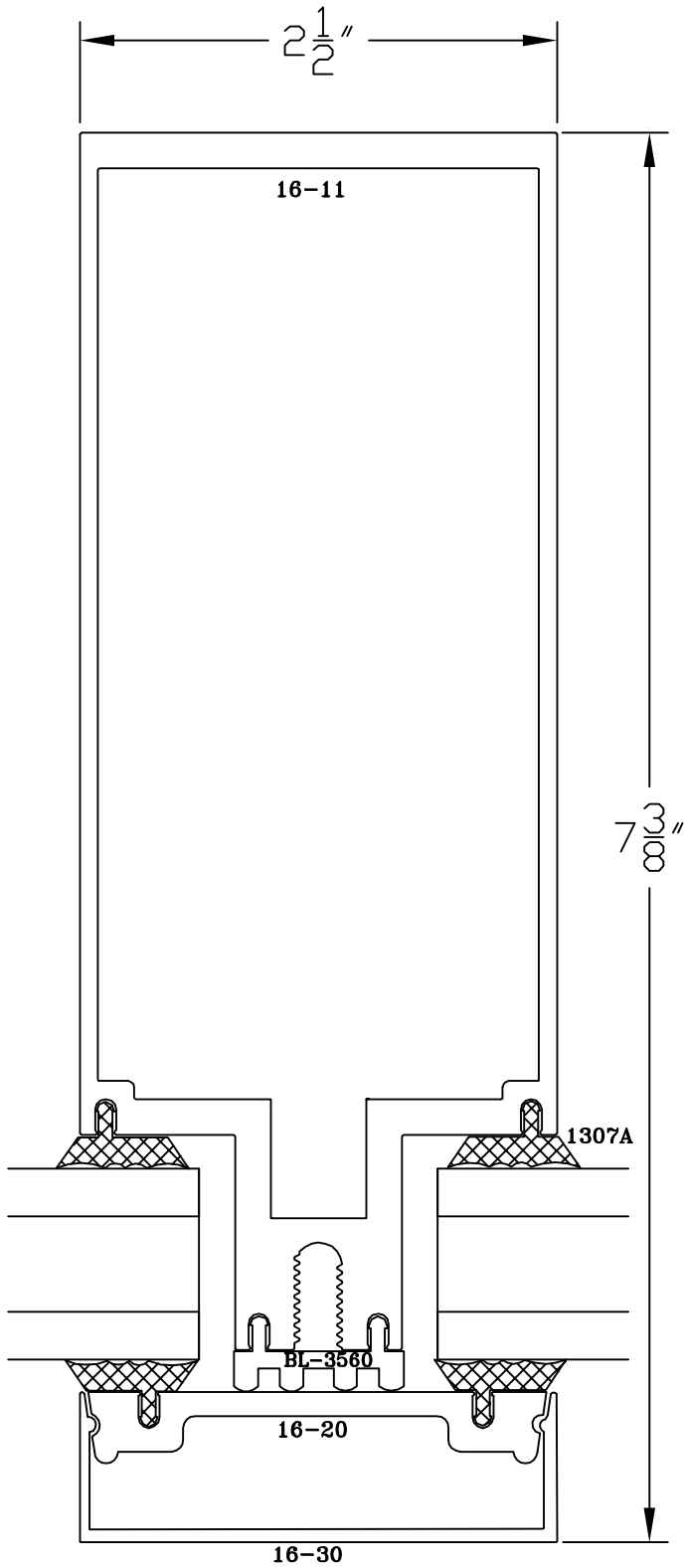

⑧ VERTICAL

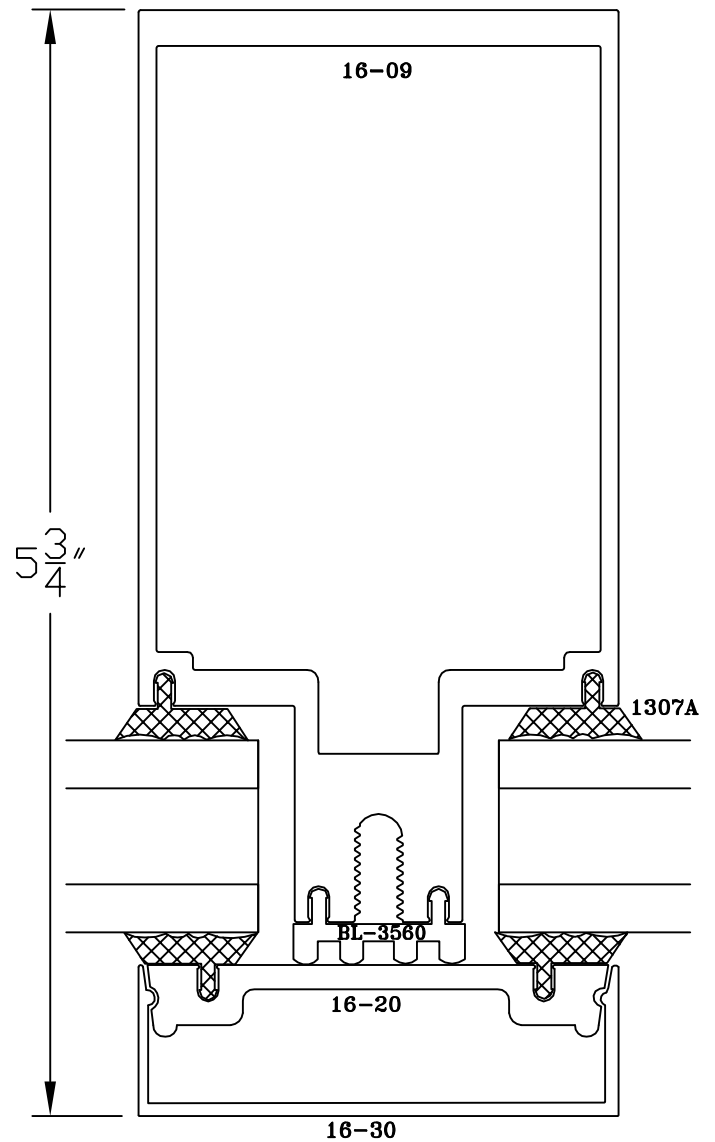

⑧A VERTICAL

MARLIN
WINDOWS, INC

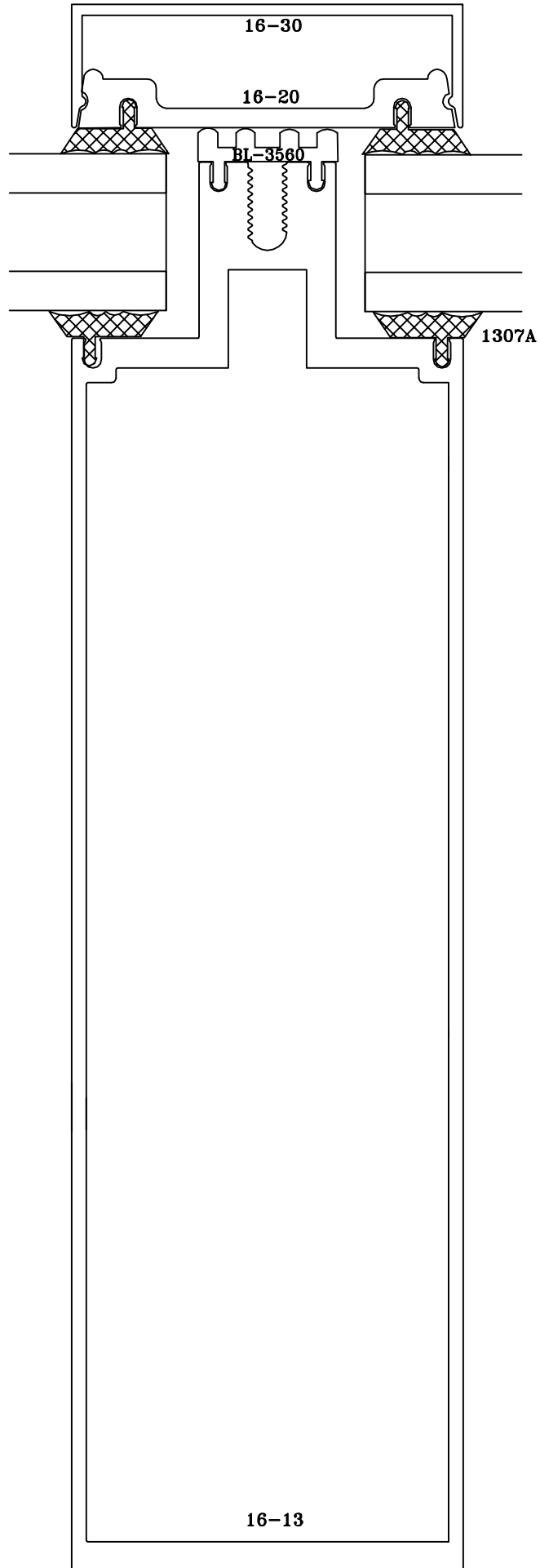

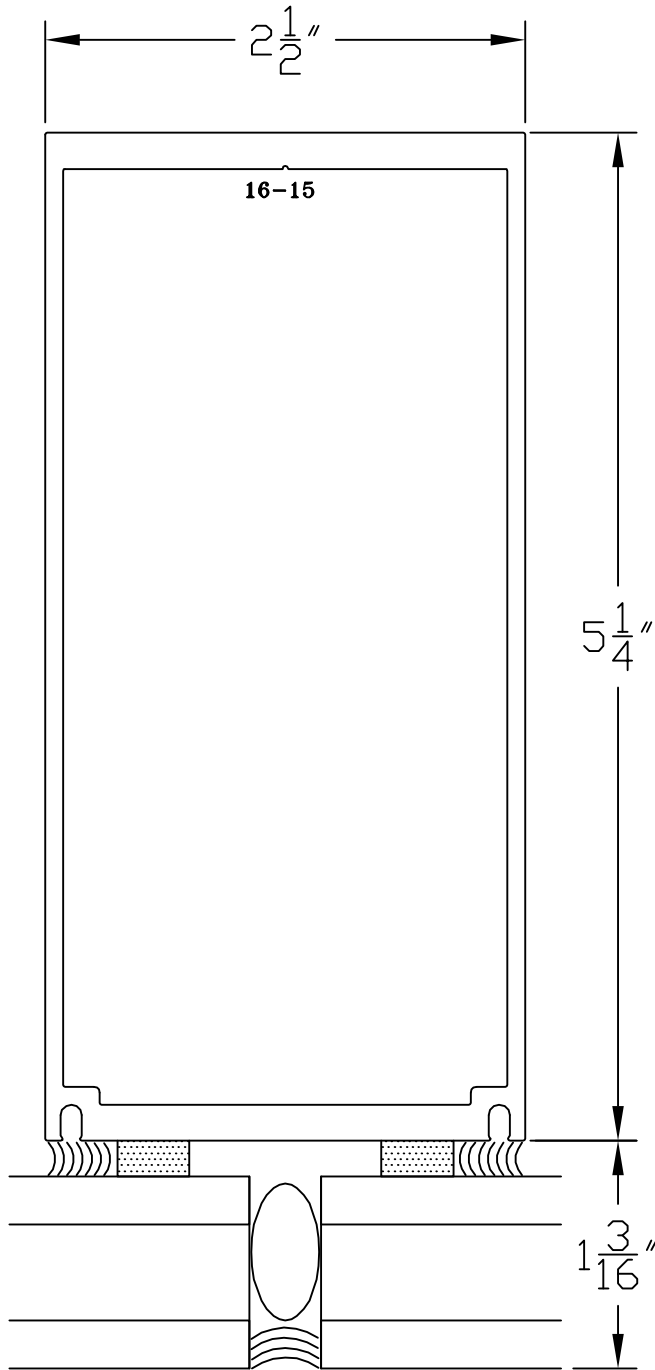

8B VERTICAL
BUTT GLAZE

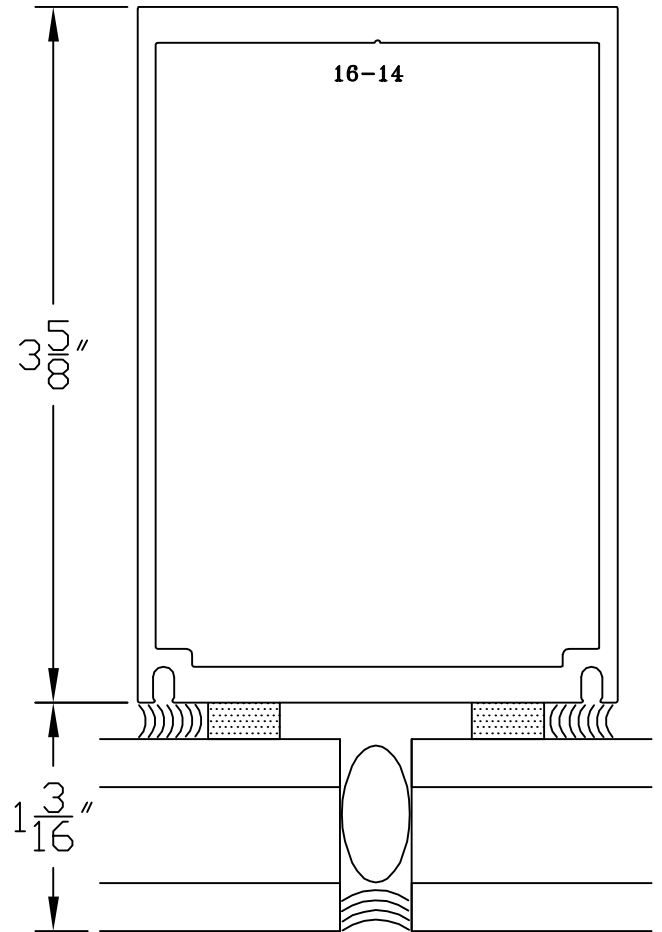

8C VERTICAL
BUTT GLAZE

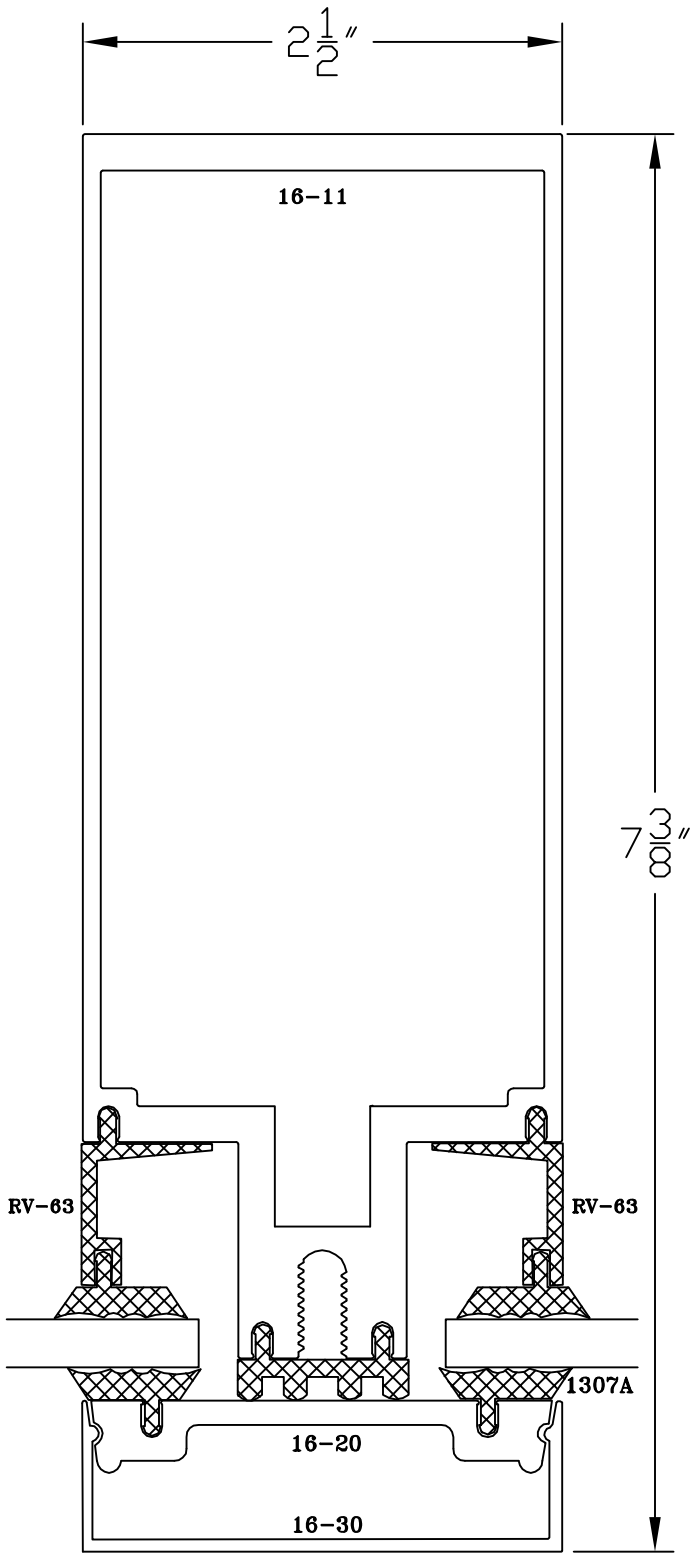

9 VERTICAL

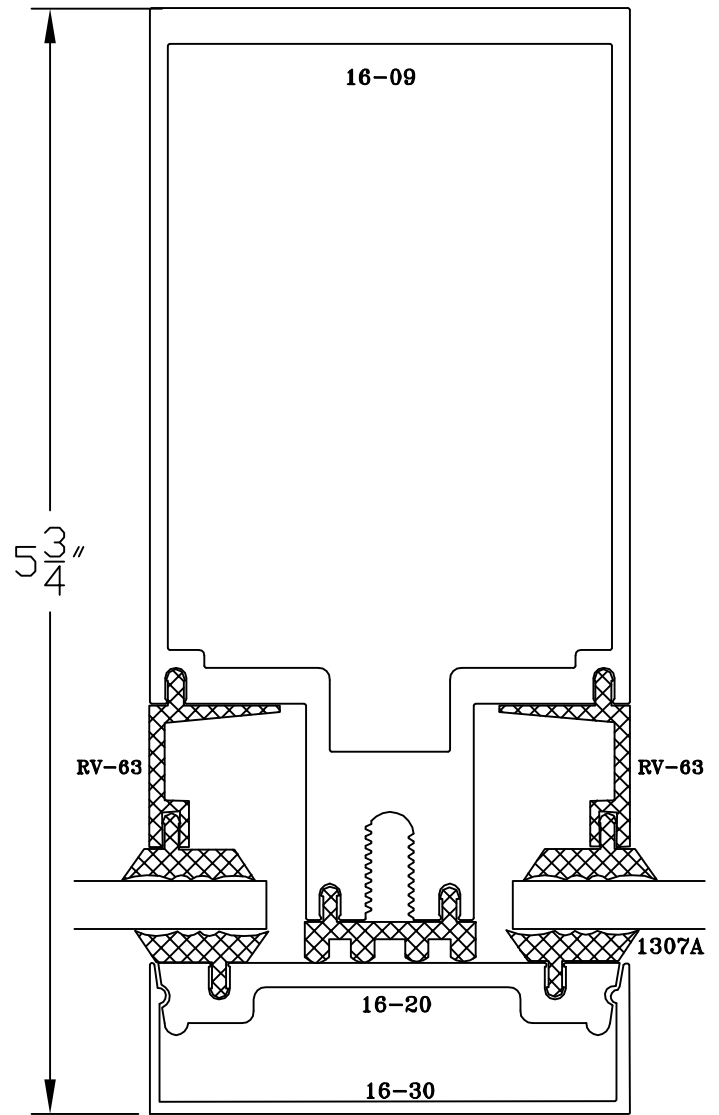

9A VERTICAL

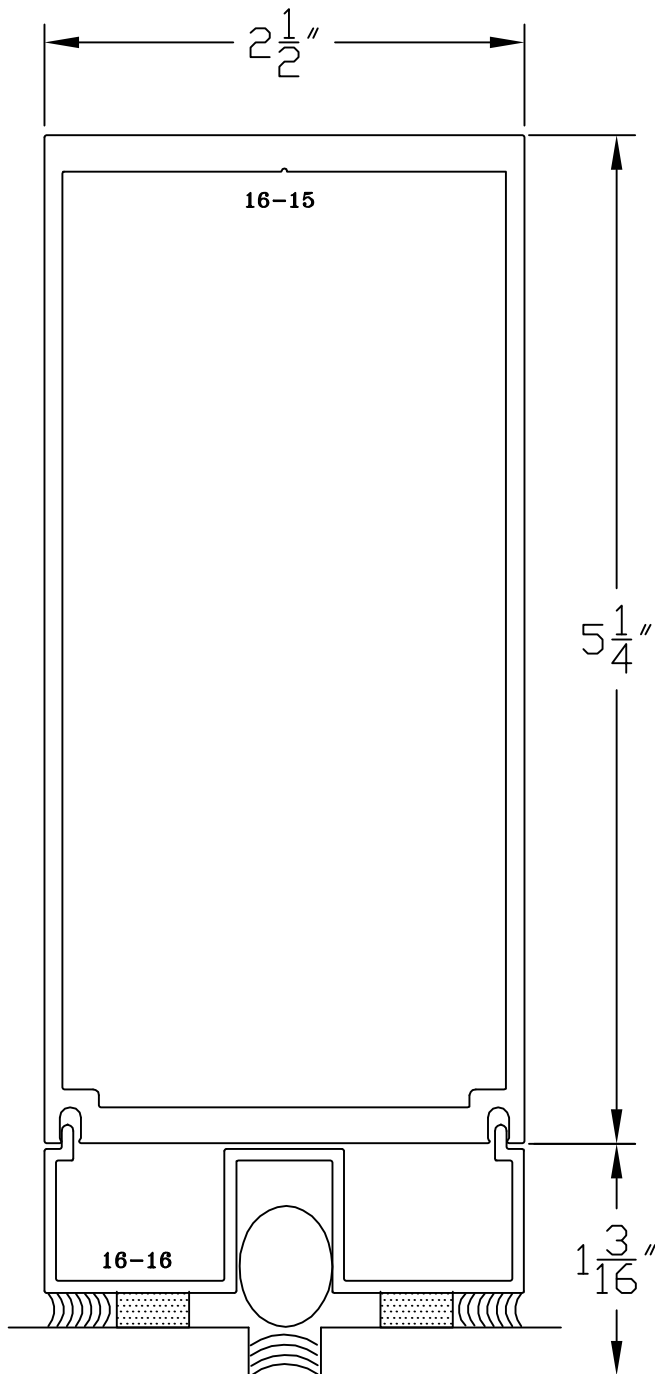

9B VERTICAL
BUTT GLAZE

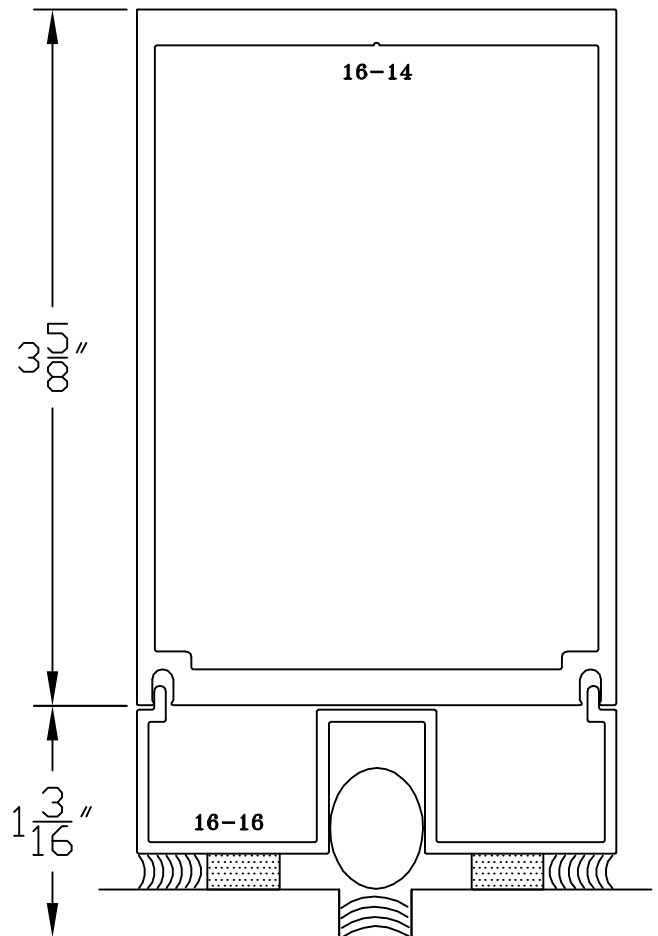

9C VERTICAL
BUTT GLAZE

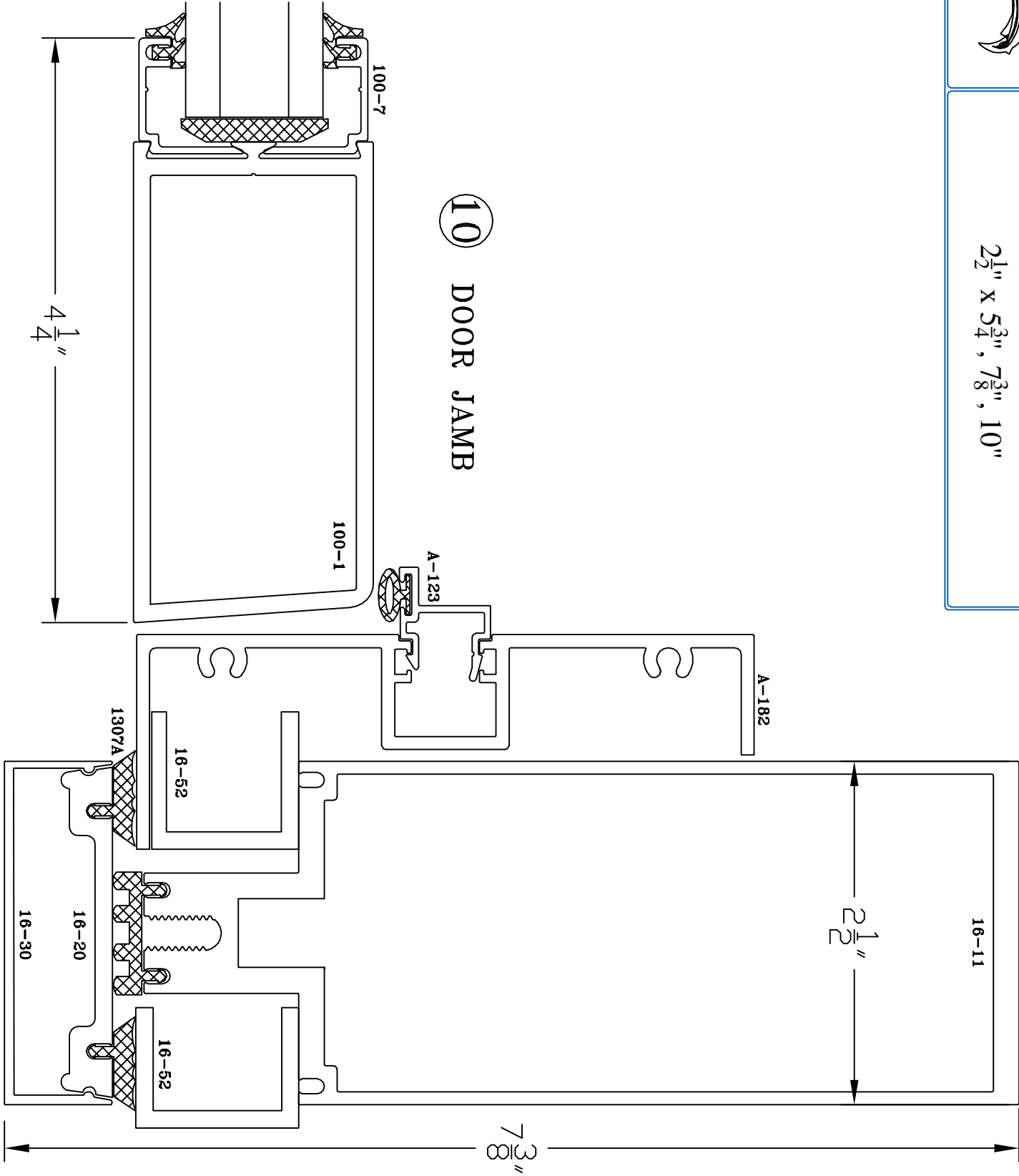

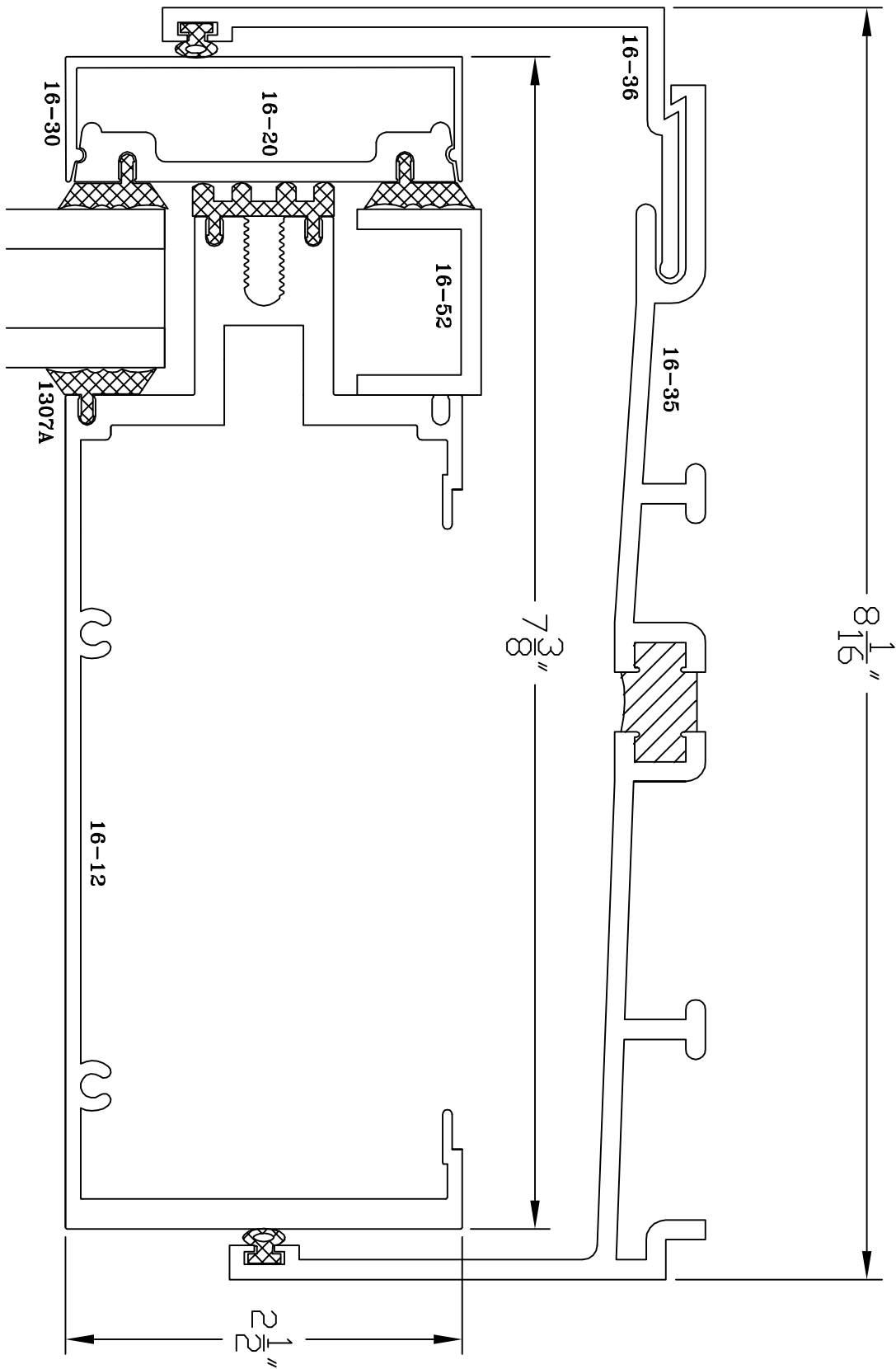

COMPENSATING
HEAD CHANNEL

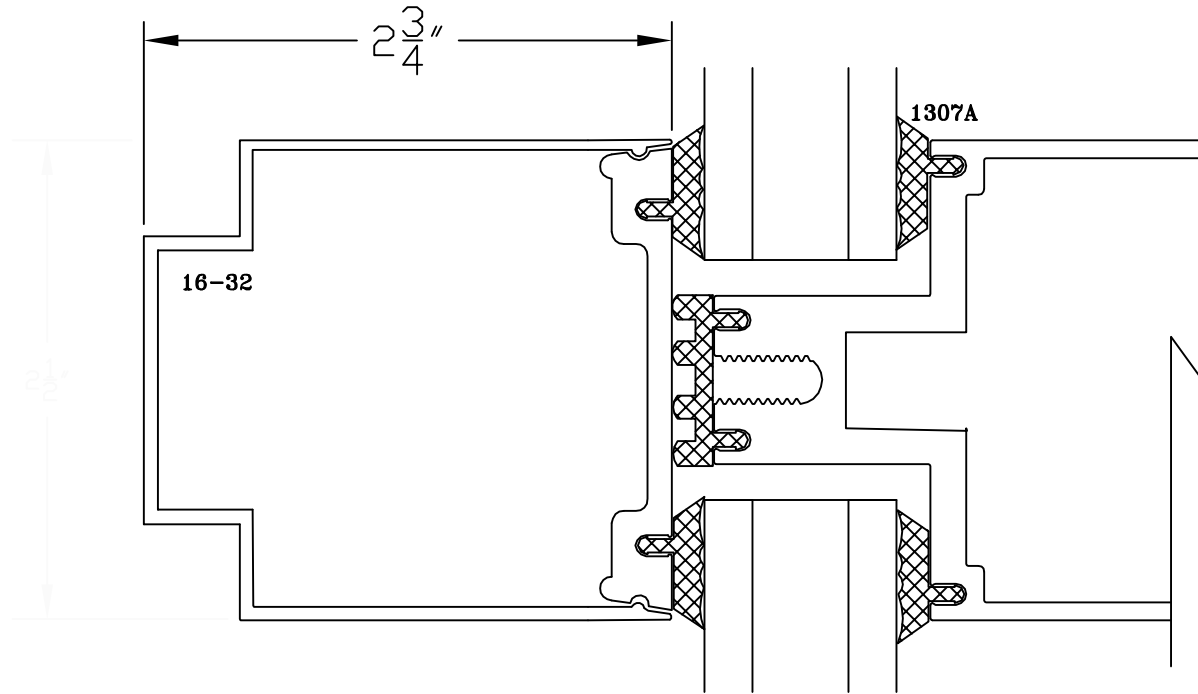

2 3/4" x 2 1/2" BEAUTY CAP

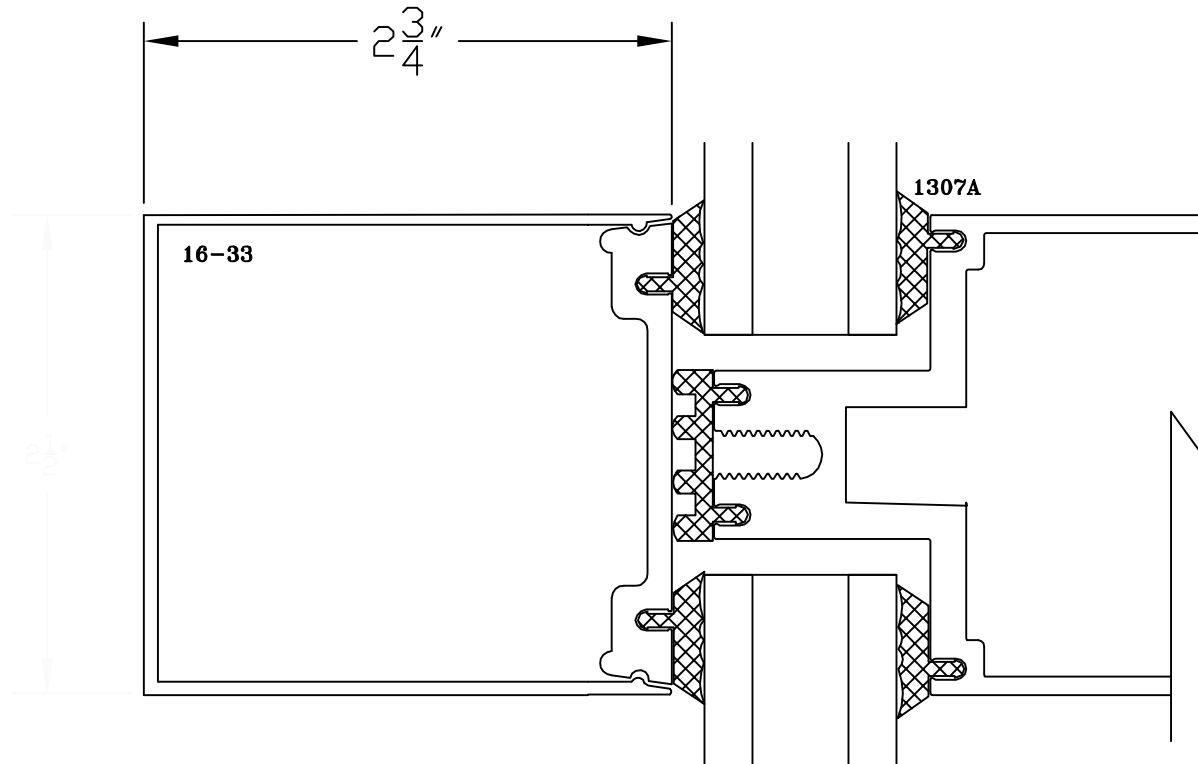

2 3/4" x 2 1/2" CAP

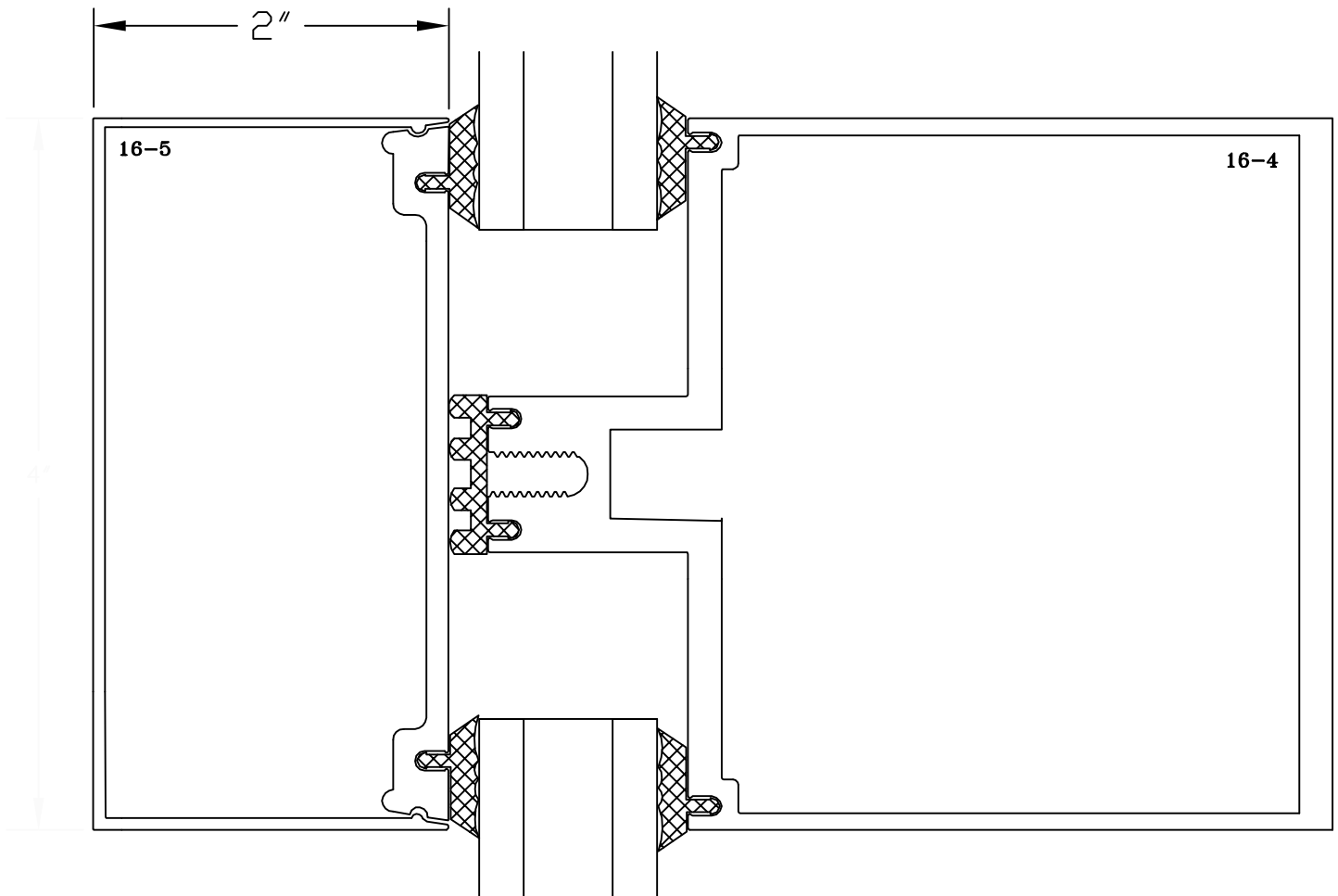

2" x 4" CAP W/4" HORIZONTAL

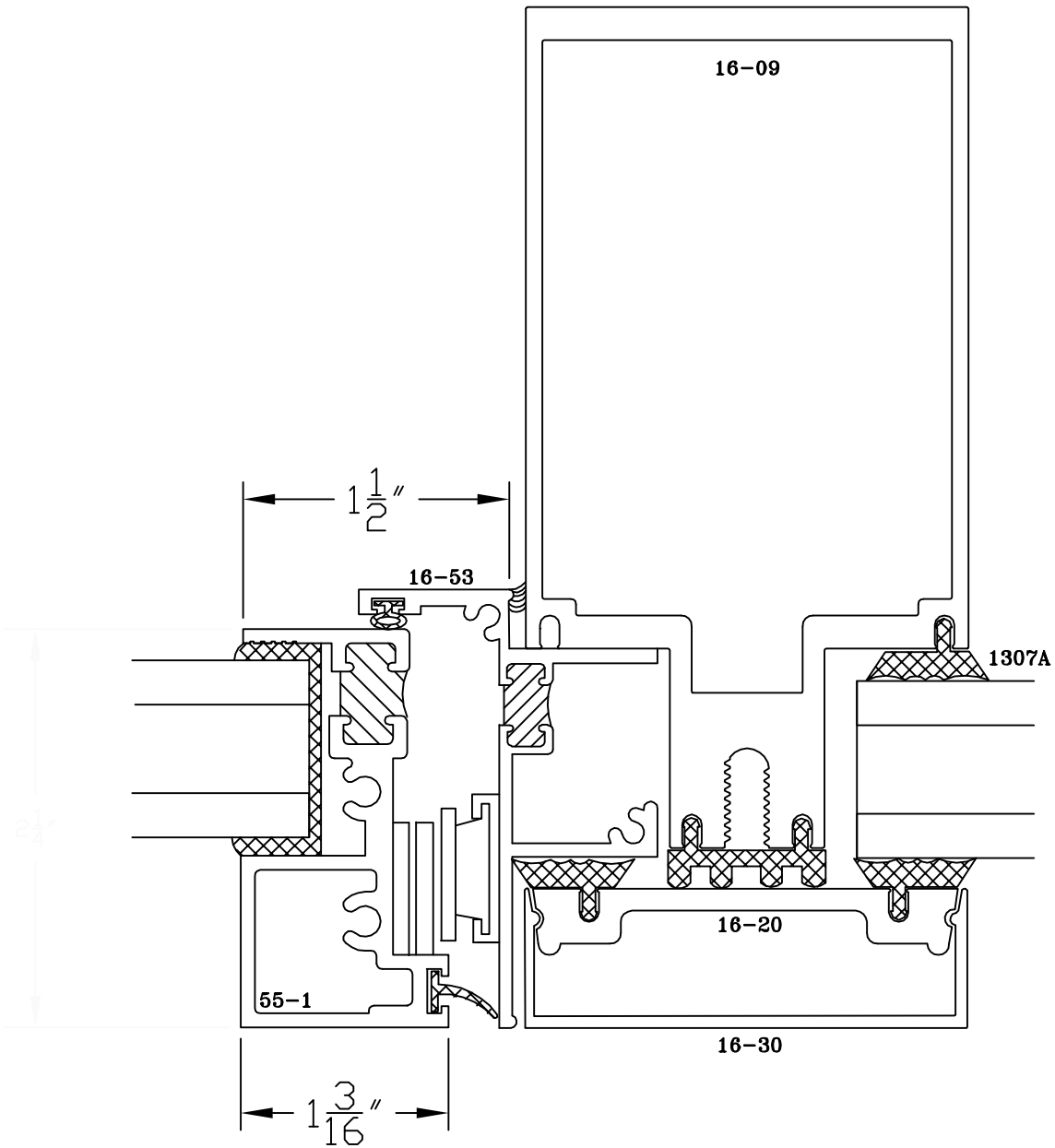

LOW PROFILE VENT

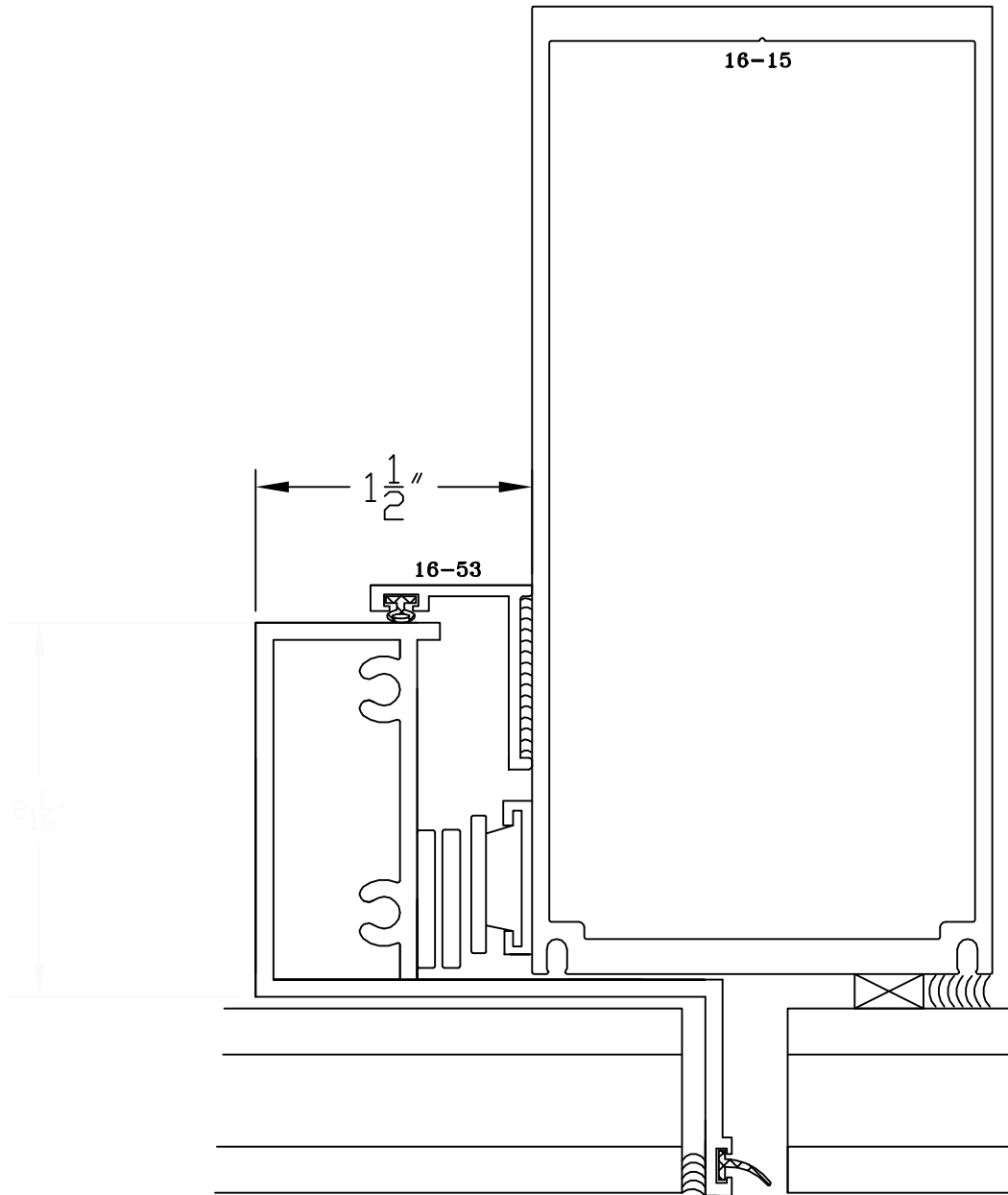

CONCEALED CURTAINWALL
VENT @ BUTT GLAZE

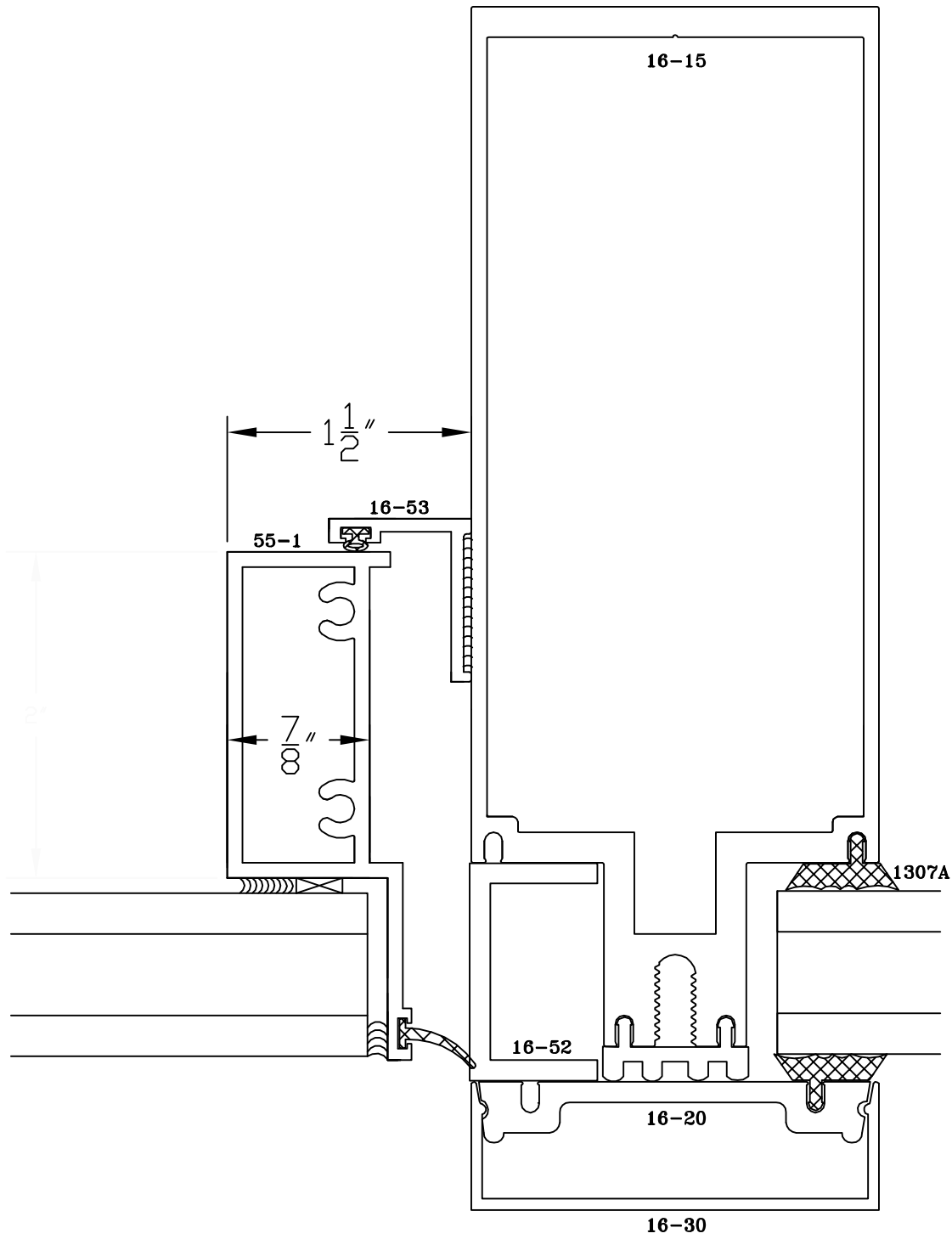

CONCEALED CURTAINWALL VENT