

## Specifications

### GENERAL

Aluminum entrance shall be Marlin series 5.0 as manufactured by Marlin windows. Frames, sidelights, and fixed windows shall be of the same manufacturer. If substitute materials are utilized, they are required to be supported by proper specifications and technical drawings no less than ten working business days prior to bid for consideration.

### MATERIALS

All door and framing shall be aluminum alloy & temper. Stiles and rails shall be 3/16" in thickness and shall be tubular in shape. All weathering shall be silicone treated polypropylene. Any exposed fasteners shall be stainless steel or aluminum.

### FINISH

Standard architectural Class II anodic color conforming to Aluminum Association AA-M12-C22-A34 for dark bronze or AA-M12-C22-A31 for clear anodize. (Architectural Class I anodic finish and organic coatings available).

### CONSTRUCTION

Aluminum stiles and rails are formed with butt joints to form tight fitting joints, secured with concealed brackets and anchored with bolts and screws and are fully welded. Doors shall have snap in stops with bulb style glazing vinyl on each side. No exposed screws shall be permitted. Adjusting mechanisms shall be located in the top rail near the lock stile. All glazing shall be flush, including the horizontal muntins and sills and held in place by E.P.D.M. glazing gaskets.

### HARDWARE

All doors shall be equipped with a maximum security hookbolt lock. Pair of doors shall be equipped with lever type flush bolts located in the top and bottom of the inactive meeting stiles. Operating hardware shall be butt hinges, offset pivots, or center pivots as supplied by the door manufacturer. Closers for butt hung and offset pivoted doors shall be door manufacturer's stand surface closer. Closers for center pivoted doors shall be door manufacturer's standard overhead concealed closers. All butt hung and offset pivoted doors shall have a Marlin pull handle and 1" diameter push bar. All center pivoted doors shall have 1" diameter push bars on both sides.

### CUSTOM HARDWARE

If hardware items are to be supplied to the door manufacturer by others, templates and physical hardware must be submitted to the door manufacturer prior to fabrication.

### GLAZING

Marlin entrances shall accommodate 1" glazing as required. Provisions for 1/4" glazing shall be accommodated by use of an adapter.

### INSTALLATION

Glass and framing shall be installed straight, plumb, and level without twisting and securely anchored in place. All joints between framing and the building exterior shall be sealed to provide a watertight installation.

### PROTECTION AND CLEANING

The General Contractor shall provide adequate protection of the aluminum and glass surface from damage by grinding compound, lime, acids, cement or other contaminants. The General Contractor shall be responsible for final cleaning.

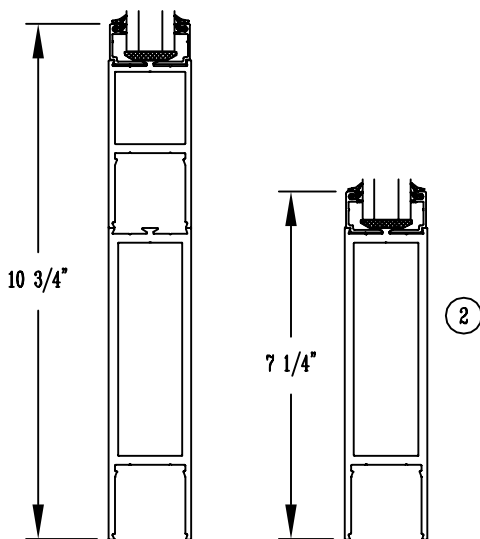
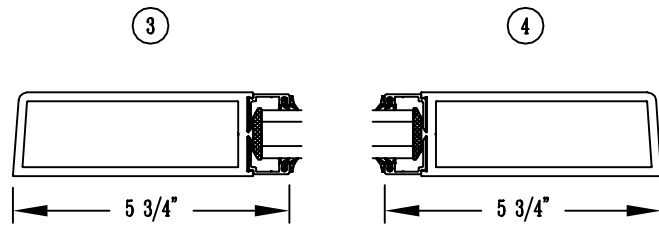
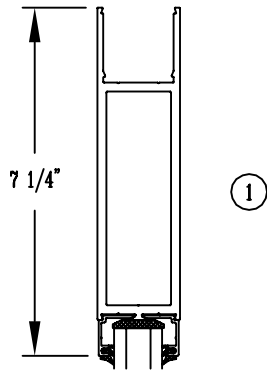
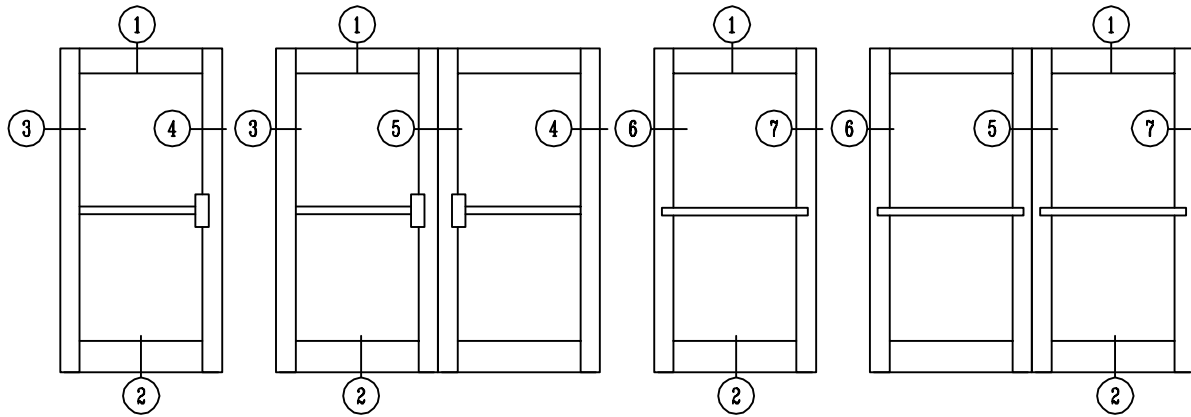

OPTIONAL

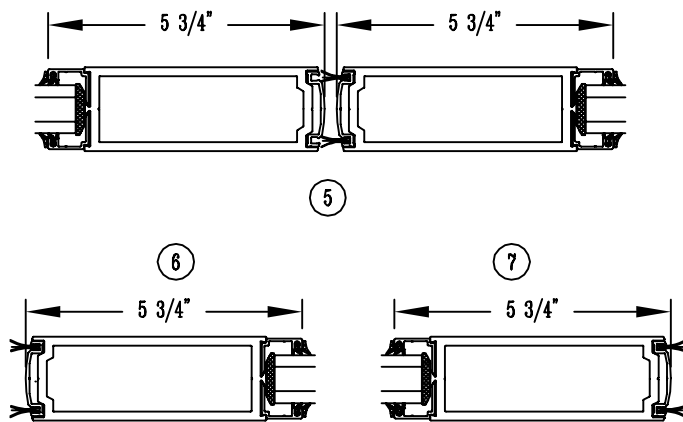

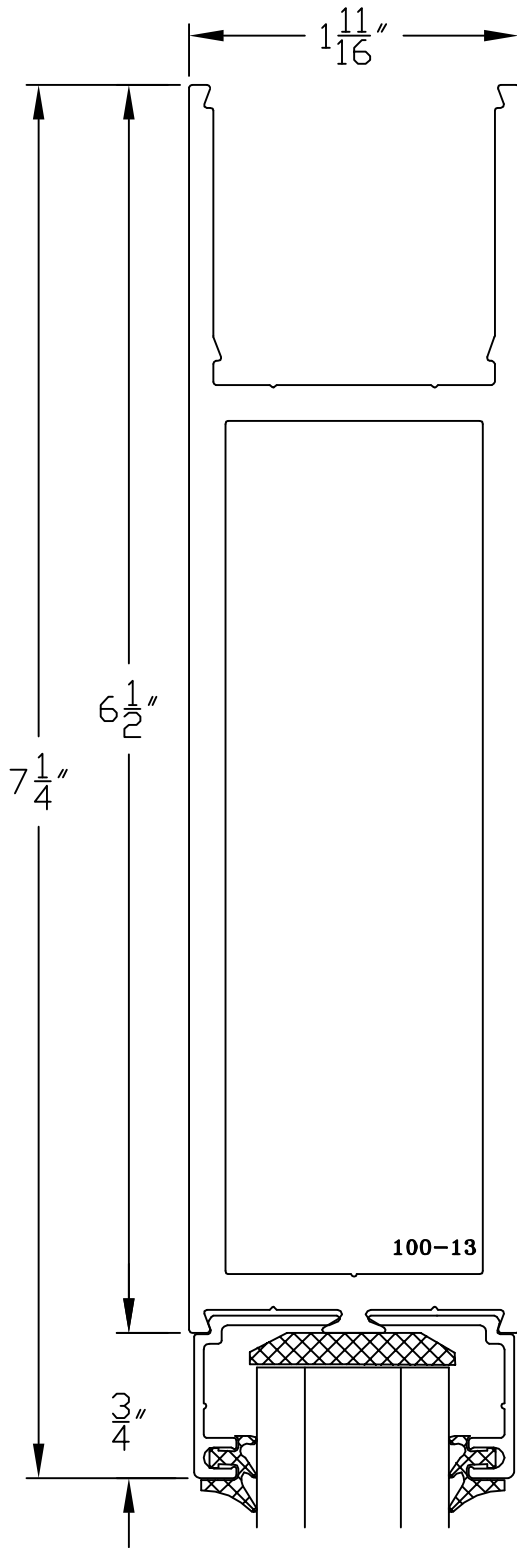

1 HEAD

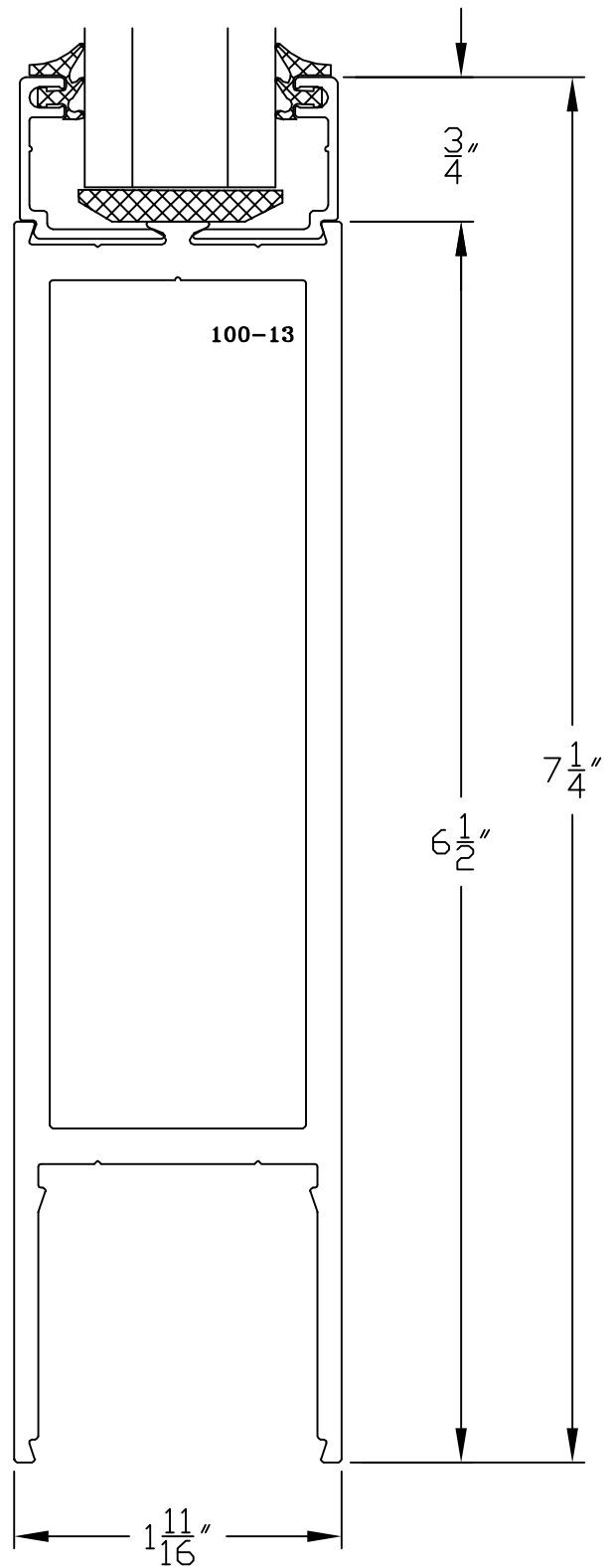

2 BOTTOM RAIL

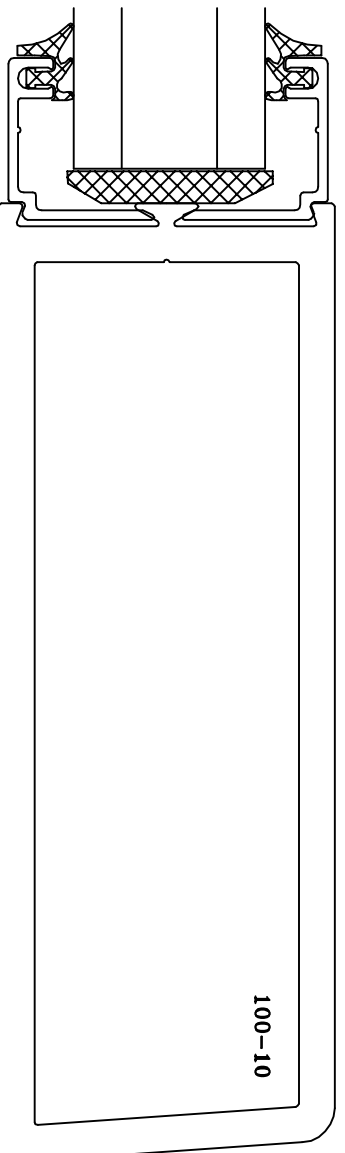
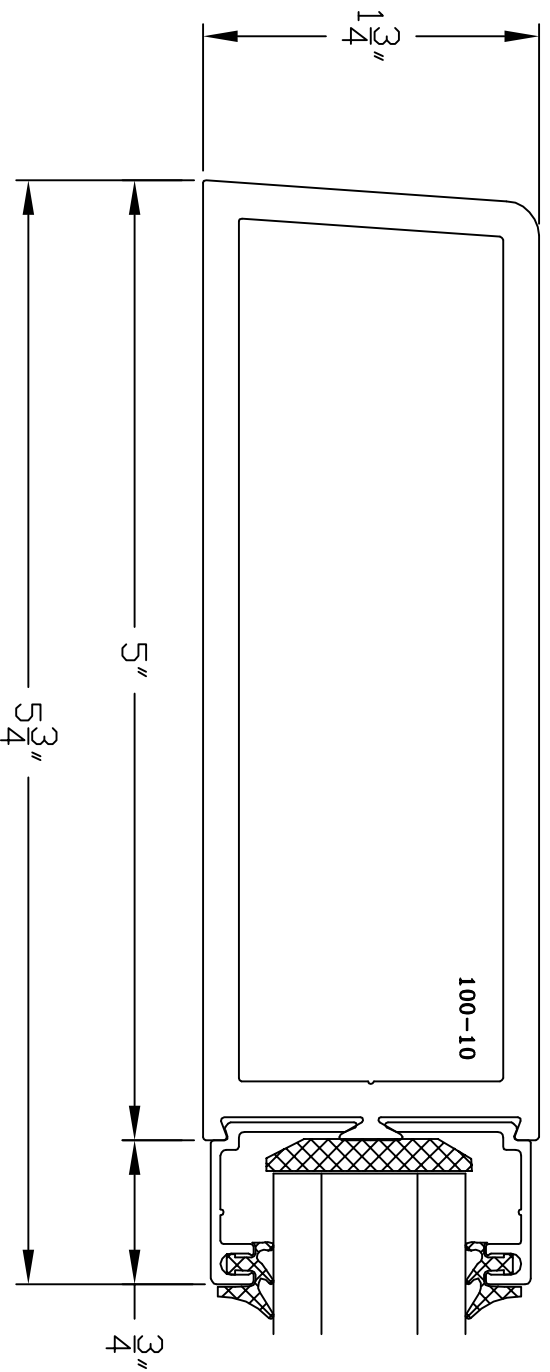

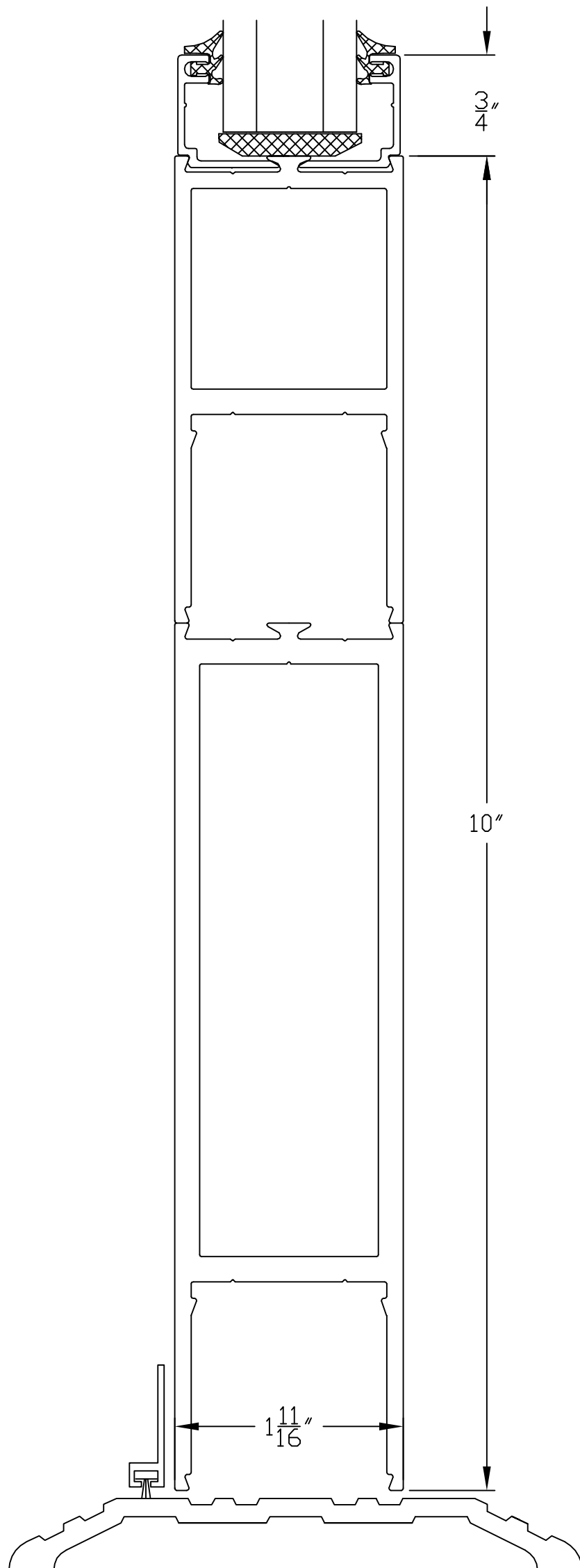

OPTIONAL 10" BOTTOM RAIL

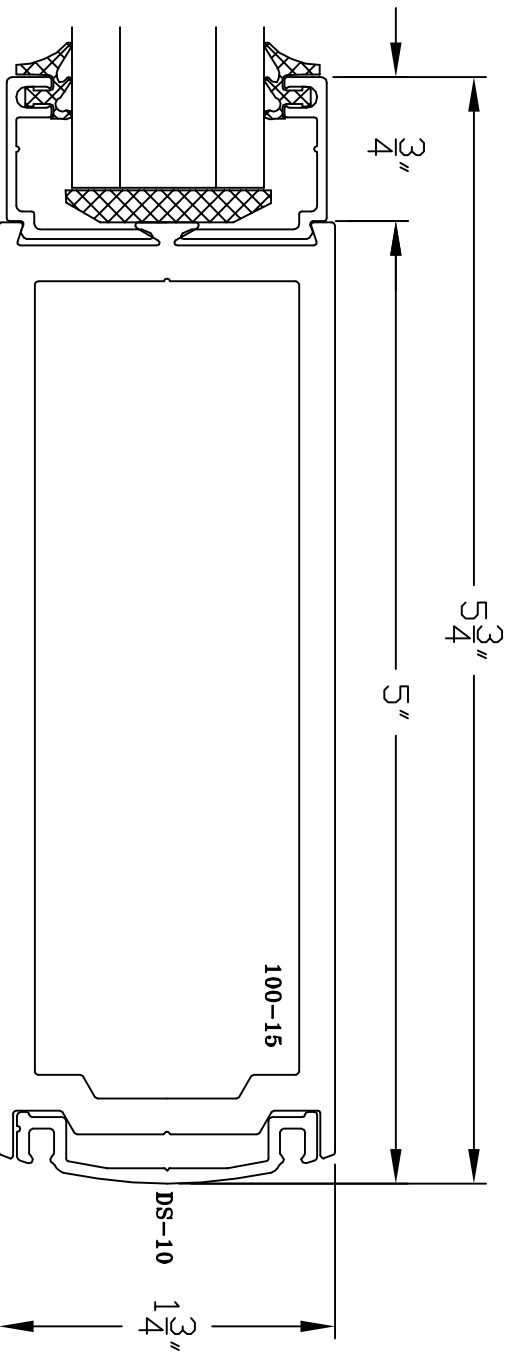

5 DOOR JAMBS

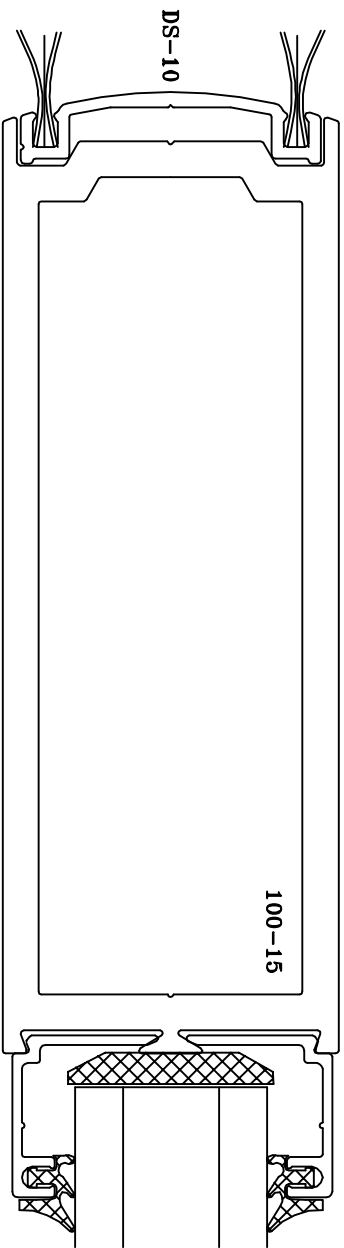

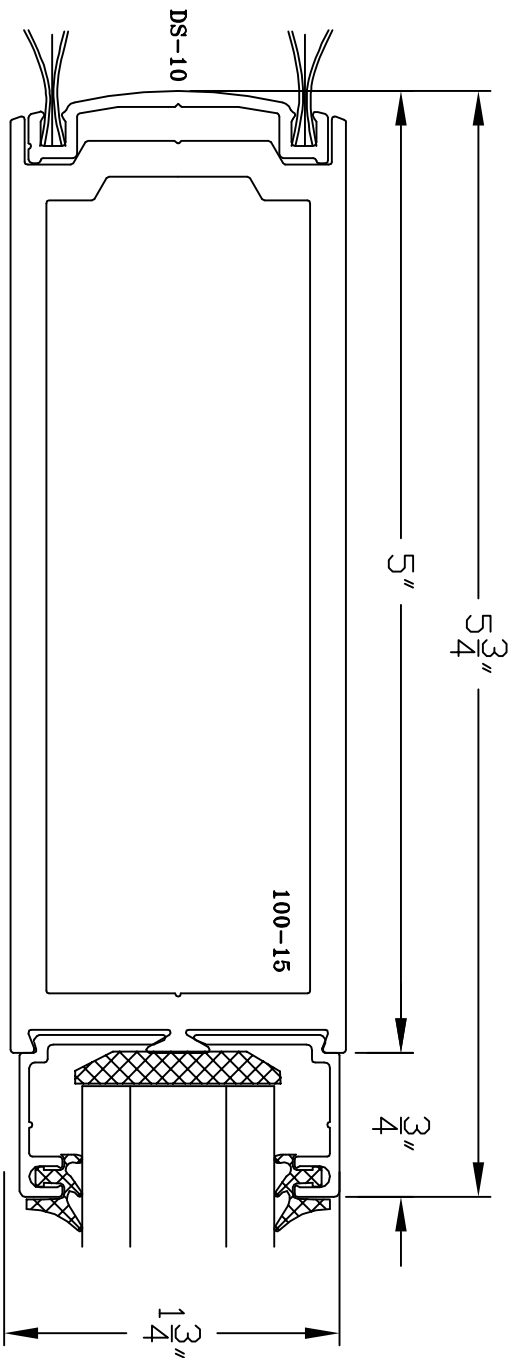

6 DOOR JAMB

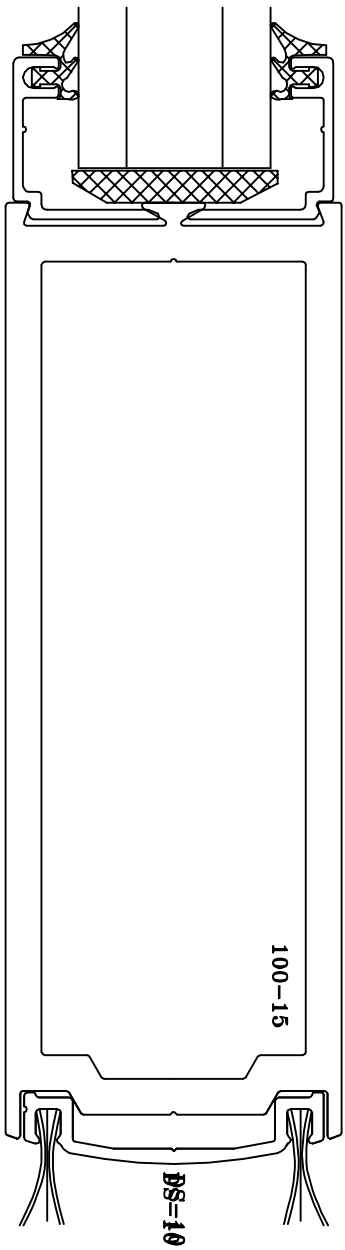

7 DOOR JAMB