

ADVERS LLC
Russia, 443068, Samara, ul. Novo-Sadovaya 106
Production
+7(846)263-07-97

Sales
Autoterm LLC
Triekatas street 4, Riga, Latvia, LV-1026
+371 20110229
E-mail: sales@autoterm-europe.com

Service
Autoterm LLC
Triekatas street 4, Riga, Latvia, LV-1026
+371 25529999
E-mail: service@autoterm-europe.com



QSTART Modem

Quick Start Guide

AT.100.00.00.001 NE



Scan the QR code to download the Autoterm Control application.

1. Purpose

The GSM-SIMCOM modem is designed for use in BINAR-5-Compact, BINAR-5S, 14TC-10, and 14TC-mini liquid pre-heaters and in PLANAR air heaters (referred to for ease as “product” or “products” throughout).

The modem is used for manual and automatic control of the product and for sending data to a phone using SMS messages.

2. Specifications

No.	Name	Characteristics
1	Voltage (V): upper limit - lower limit -	32 10
2	Operating temperature range	from -40°C to +85°C
3	Dimensions (excluding antenna and cable)	(75 x 75 x 22) MM

3. Packing

- modem (1);
- modem connection harness (2);
- antenna (3);
- quick start guide.

4. Modem Description

Figure 1 shows an external view of the modem. The following are located on the modem:

- 6-pin cable connector (1);
- antenna connector (2);
- LED's (3).

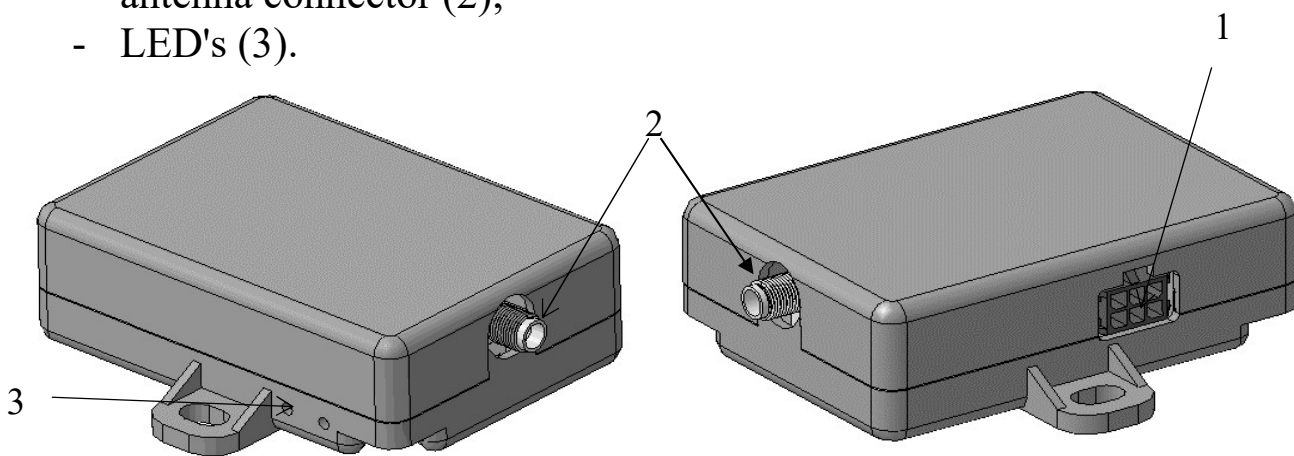

Fig.1. Modem

4.1. SIM Card Setup

First of all put new SIM card in phone, remove PIN code and delete all preset contacts from it.

Attention! SIM card has to be without voicemail. Ask your network provider to remove voicemail option from your SIM card.

To insert SIM card unscrew two screws from bottom of modem and take off top casing of modem.

Insert the SIM card in the slot as shown in Fig.2. with contacts facing down, push carefully until a click. Then it is secured in its position.

To assemble modem back, do previous steps backward.

Figure 2 shows an internal view of the modem. The following are located on the modem:

- 6-pin cable connector (1);
- antenna connector (2);
- SIM card slot (3).

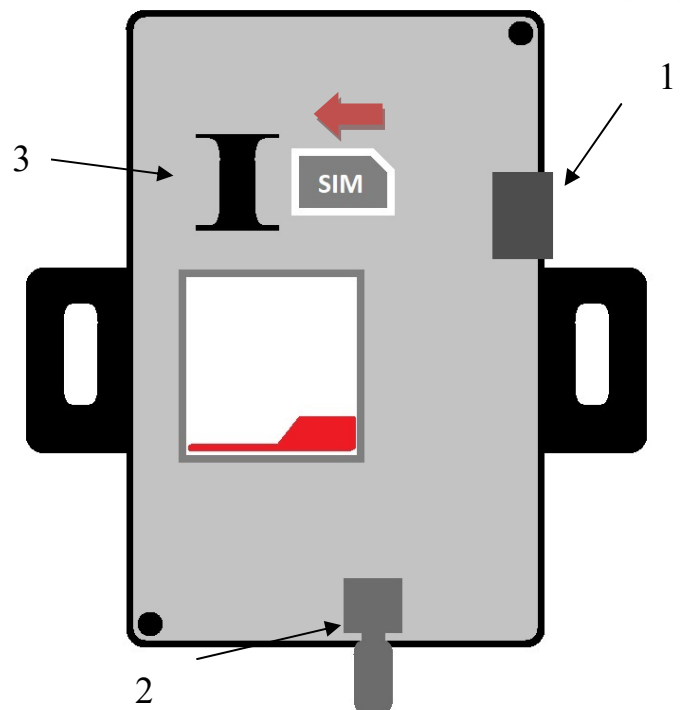

Fig. 2.To insert SIM card

4.2. Modem Connection

To set the modem up, connect the antenna, connect the harness to the modem and place the modem in a clean location. Mount the antenna in an unobstructed location (for example, on the windshield).

To connect the cable to the modem, push it in the connector until a click, so the cable connector is fixed in place.

To disconnect the cable, depress the connector latch.

To connect the modem to the product, disconnect the control panel from the product harness and connect the harness to the modem as shown in Fig.3.

After connecting the modem to the power harness (modem power supply), the LED closest to the antenna connector starts to glow. The second LED will start to blink (connection and data exchange).

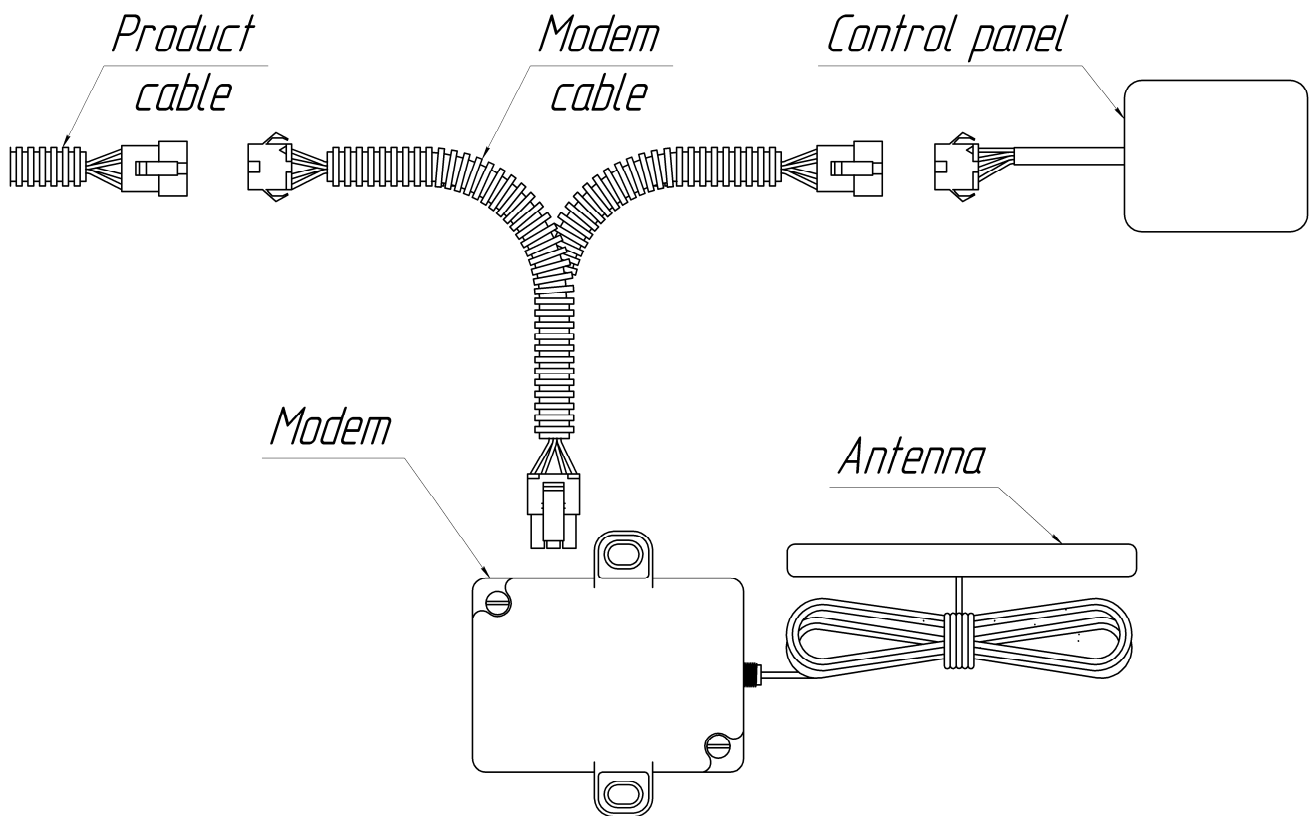

Fig. 3. Modem connection to BINAR-5-Compact, BINAR-5S, and PLANAR

4.3. Preparation of SIM Card

To control the pre-heater by means of SMS-commands, phone numbers of SIM cards from which you plan to maintain control should be added to the contacts of the modem SIM card.

Insert the SIM card in the modem and turn on the power supply. When the connection is established (the LED indicating connection to the network is blinking slowly), you can add trusted numbers.

Attention! The first phone number to add is that of the Administrator. All further actions with trusted numbers are made only from this number.

Attention! Commands must be written in lowercase.

Adding the Administrator phone number:

Adding a trusted phone number:

Example of working with trusted numbers using SMS-commands:

Direction	SMS text	Description
To modem	admin+71234567891	Adding administrator number
Modem response	Admin:+71234567891	
To modem	add+71234567892	Adding trusted number
Modem response	1. +71234567891 2. +71234567892	
To modem	add+71234567893	Adding trusted number
Modem response	1. +71234567891 2. +71234567892 3. +71234567893	
To modem	list	Viewing the list of trusted numbers
Modem response	1. +71234567891 2. +71234567892 3. +71234567893 4. +71234567894	
To modem	del2	Removing trusted number No. 2
Modem response	1. +71234567891 3. +71234567893 4. +71234567894	
To modem	signal	Shows network strength and provider
Modem response	GSM signal: 3 Provider: Orange	Scale form 1-5.

5. Controlling the Product.

Product can be controlled in three ways:

- 1) by means of a telephone call;
- 2) by means of a mobile application;
- 3) by means of SMS messages (dialed manually).

6. Controlling the Product by Means of a Telephone Call

The product can be controlled only from a trusted phone number. When you call the modem number:

- If the product is stopped, the modem will respond with three beeps and will start the product.
- If the product is running, the modem will respond with two beeps and will stop the product.

7. Controlling the Product by Means of a Mobile Application

The product can be controlled by means of an application installed on a mobile phone with Android or iOS operating system. To do this, you need to download the app Autoterm Control from Play Market or from AppStore and install it on your phone.

After installation, click the Autoterm Control application to start it.

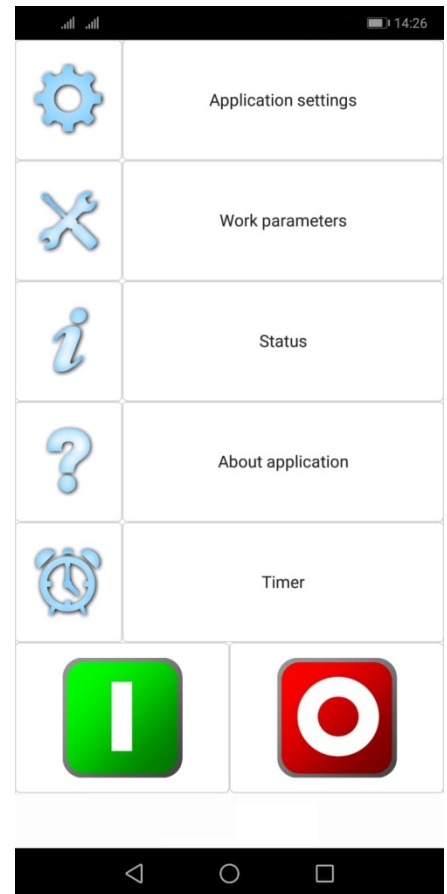

Autoterm Control settings:

- adding the product¹;
- ON/OFF SMS notifications;
- ON/OFF SMS malfunction notifications;
- confirm sending SMS;
- call notification²;
- language selection;
- about the product³.



Operation settings:

- set operation time of the pre-heater⁴;
- ON/OFF cabin heater;
- set cabin heater ON temperature;
- ON/OFF pump start-up at engine start;
- set temperature of pre-heater transition to standby mode;
- ON/OFF product control from the alarm system remote;
- ON/OFF auxiliary heater mode.



Requesting the current status of the product.



Account balance request on the modem card number.



Product start-up (if SMS notification is enabled, an SMS-message is returned confirming the start-up of the product).



Product shutdown (if SMS notification is enabled, an SMS-message is returned confirming the shutdown of the product).

- 1 – Enter the number in the following format:
(country code) (city/wireless carrier code) (phone number)

Example number: +71231234567

When adding a PLANAR heater and a 14TC pre-heater, select SIMCOM in the Modem section.

- 2 – When a voice call to the modem number is made, an SMS status notification is returned.
- 3 – Information on the serial number of the pre-heater, the software version of the electronic unit and modem software version are returned.
- 4 – Operation time can be set even when the product is running.

9. Overall Testing of Modem after Installation

After the installation and connection of the modem to the product, the modem is tested in the following manner:

- Check that the red LED is lit (closest to the antenna connector);
- Request the status of the product.

If an SMS response is returned after the request, the modem is installed correctly.

If the LED is not lit, check the wires and connectors of the modem harness.

The second LED flashes - modem with a SIM card communicates with the operator.

12. Warranty

12.1 The warranty period is 24 months from the date of sale of the product, on condition that the user complies with handling, transportation and storage requirements and as provided by the operation manual.

12.2 In the absence of the stamp of the seller organization with the date of sale the warranty period is calculated from the date of manufacture of the modem.

12.3 When a fault occurs during the warranty period due to the fault of the manufacturer, the modem is replaced by the manufacturer.

12.4 The manufacturer shall not accept claims on incompleteness of delivery or mechanical damage after the sale of the product.

12.5 This warranty does not cover defects resulting from:

- Force majeure (lightning, fire, flood, flooding, harmful voltage fluctuations, accident);
- Non-compliance with the rules of installation, operation, storage and transportation set forth in the operating instructions;
- Use of modem for other purposes.

12.6 In case the operation manual for the modem is lost, the user is deprived of the right to warranty service.

13. Full manual:

For not Smartphone or APP users you can find full manual at our homepage:

<https://autoterm-europe.com/manuals>

