

# Vi035-6A

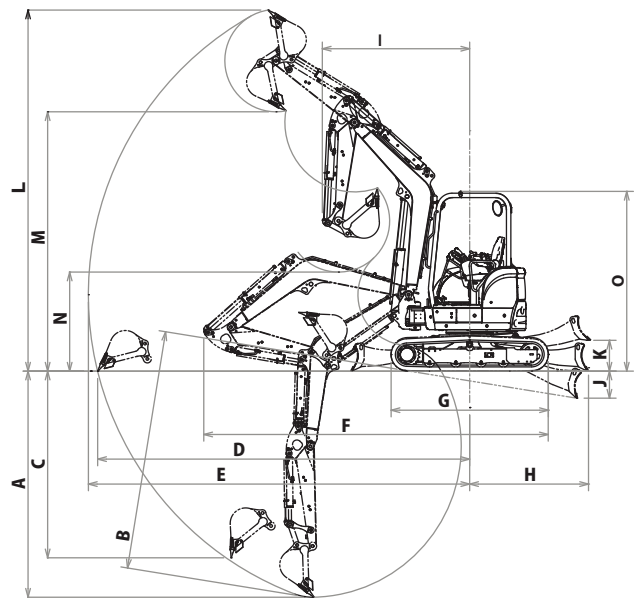

## Dimensions - Vi035-6A

<b>A</b> 10 ft. 8 in. (3,250 mm)	<b>L</b> 16 ft. 9 in. (5,110 mm)
<b>B</b> 11 ft. 3 in. (3,440 mm)	<b>M</b> 11 ft. 2 in. (3,410 mm)
<b>C</b> 7 ft. 11 in. (2,410 mm)	<b>N</b> 4 ft. 1 in. (1,240 mm)
<b>D</b> 17 ft. 3 in. (5,270 mm)	<b>O</b> 8 ft. 1 in. (2,470 mm)
<b>E</b> 17 ft. 8 in. (5,390 mm)	<b>P</b> 1 ft. (300 mm)
<b>F</b> 15 ft. 8 in. (4,770 mm)	<b>Q</b> 4 ft. 9 in. (1,440 mm)
<b>G</b> 7 ft. 1 in. (2,160 mm)	<b>R</b> 5 ft. 9 in. (1,740 mm)
<b>H</b> 5 ft. 4 in. (1,630 mm)	<b>S</b> 2.6 in. (65 mm)
<b>I</b> 7 ft. 1 in. (2,170 mm)	<b>T</b> 1 ft. 11 in. (590 mm)
<b>J</b> 1 ft. 3 in. (370 mm)	<b>U</b> 0.6 in. (15 mm)
<b>K</b> 1 ft. 5 in. (425 mm)	<b>V</b> 5 ft. 9 in. (1,740 mm)
	<b>W</b> 2 ft. 7 in. (775 mm)

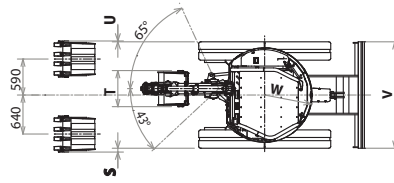
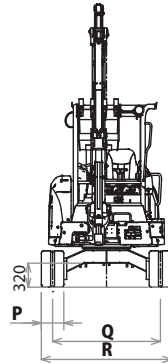

## Specifications

Model		Vi035-6A	
Type		Canopy	Cabin
<b>Operating Weight</b>	Rubber track	lbs (t)	7,905 (3.58)
	Steel track	lbs (t)	8,125 (3.68)
<b>Engine</b>	Type	Water-cooled 4-cycle diesel	
	Model	3TNV88F-ESBV	
	Rated Output	HP (kW)/rpm	24.4 (18.2) / 2,200
<b>Performance</b>	Max Digging Force, Bucket / Arm	lbs (kN)	7,216 (32.1)* / 4,586 (20.4)*
	Traveling Speed, High / Low	MPH (km / h)	2.7 (4.5) / 1.6 (2.7)
	Swing Speed	RPM	9.5
	Boom Swing Angle, (L / R)	degrees	43 / 65
<b>Ground Contact Pressure (Rubber Track)</b>		PSI (kPa)	4.80 (33.1)   4.97 (34.3)
<b>Hydraulic System</b>	Pump Capacity	GPM (L / min)	9.8 (37.0) x 2 <Variable displacement pump> 6.9 (26.2) x 1, 2.9 (10.8) x 1 <Gear pump>
	Main Relief Set Pressure	PSI (MPa)	3,205 (22.1) x 2, 3,133 (21.6) x 1
<b>Blade Dimensions</b>	Width	ft-in (mm)	5' 8" (1,740)
	Stroke, Raise / Lower from G.L.	ft-in (mm)	1' 5" (425) / 1' 3" (370)
<b>Fuel tank capacity</b>		Gals (L)	10.8 (41)

\*without quick coupler

## Standard Equipment

- Hydraulic Quick Coupler\*
- Backfill Dozer Blade
- Boom Swing Function
- Rubber Tracks
- Arm End Auxiliary Valve
- Back Mirror
- 2-way Pattern Control
- ROPS / FOPS Canopy, Cabin
- Windshield Washer
- Joystick Pilot Controls
- Arm Rests (Adjustable)
- Suspension and Reclining Seat
- Seat Belt
- Proportional Auxiliary Hydraulics Control
- Dual Speed Switch
- Auto Deceleration Switch
- Eco Mode Switch
- Engine Stop Switch
- Traveling Alarm
- Floor Mats

\*Also available without Quick Coupler.

Please note that the standard equipment may vary from this list. Consult your Yanmar dealer for confirmation.

## Hydraulic PTO

Model		Vi035-6A		
Specification	Output	PSI (MPa)	GPM (L / min)	
			2,200RPM	1,100RPM
		Combined Flow, Double Actions		3,205 (22.1)

## Lifting Capacity

LIFT POINT HEIGHT h:in (mm)	r:REACH in (mm)											
	RATED LIFT CAPACITY OVER END BLADE DOWN				RATED LIFT CAPACITY OVER END BLADE UP				RATED LIFT CAPACITY OVER SIDE BLADE UP			
	MAX	137.8(3,500)	118.1(3,000)	98.5(2,500)	MAX	137.8(3,500)	118.1(3,000)	98.5(2,500)	MAX	137.8(3,500)	118.1(3,000)	98.5(2,500)
118.1 (3,000)	1,719(780)	1,631(740)	1,609(730)		1,058(480)	1,322(600)	1,565(710)		992(450)	1,278(580)	1,565(710)	
78.7 (2,000)	1,763(800)	1,918(870)	2,138(970)	2,491(1,130)	903(410)	1,278(580)	1,653(750)	2,447(1,110)	815(370)	1,256(570)	1,543(700)	2,447(1,110)
39.4 (1,000)	1,807(820)	2,336(1,060)	2,888(1,310)	3,813(1,730)	793(360)	1,190(540)	1,521(690)	1,984(900)	749(340)	1,124(510)	1,410(640)	1,807(820)
Ground (0)	1,873(850)	2,601(1,180)	3,218(1,460)	4,012(1,820)	815(370)	1,124(510)	1,410(640)	1,873(850)	793(360)	1,058(480)	1,322(600)	1,719(780)
-39.4 (-1,000)	1,940(880)	2,403(1,090)	2,954(1,340)	3,703(1,680)	925(420)	1,080(490)	1,388(630)	1,851(840)	881(400)	1,014(460)	1,322(600)	1,675(760)
-59.1 (-1,500)	1,918(870)	2,050(930)	2,579(1,170)	3,130(1,420)	1,124(510)	1,080(490)	1,410(640)	1,851(840)	1,058(480)	1,058(480)	1,344(610)	1,675(760)
-78.7 (-2,000)	1,851(840)				1,477(670)				1,410(640)			