

# Vi035-6A

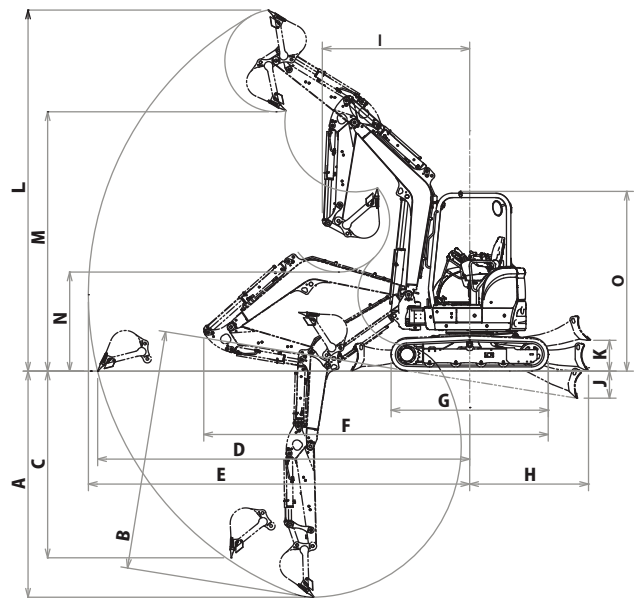

## Dimensions - Vi035-6A - Rubber Track

<b>A</b> 10 ft. 8 in. (3,250 mm)	<b>L</b> 16 ft. 9 in. (5,110 mm)
<b>B</b> 11 ft. 3 in. (3,440 mm)	<b>M</b> 11 ft. 2 in. (3,410 mm)
<b>C</b> 7 ft. 11 in. (2,410 mm)	<b>N</b> 4 ft. 1 in. (1,240 mm)
<b>D</b> 17 ft. 3 in. (5,270 mm)	<b>O</b> 8 ft. 1 in. (2,470 mm)
<b>E</b> 17 ft. 8 in. (5,390 mm)	<b>P</b> 1 ft. (300 mm)
<b>F</b> 15 ft. 8 in. (4,770 mm)	<b>Q</b> 4 ft. 9 in. (1,440 mm)
<b>G</b> 7 ft. 1 in. (2,160 mm)	<b>R</b> 5 ft. 9 in. (1,740 mm)
<b>H</b> 5 ft. 4 in. (1,630 mm)	<b>S</b> 2.6 in. (65 mm)
<b>I</b> 7 ft. 1 in. (2,170 mm)	<b>T</b> 1 ft. 11 in. (590 mm)
<b>J</b> 1 ft. 3 in. (370 mm)	<b>U</b> 0.6 in. (15 mm)
<b>K</b> 1 ft. 5 in. (425 mm)	<b>V</b> 5 ft. 9 in. (1,740 mm)
	<b>W</b> 2 ft. 7 in. (775 mm)

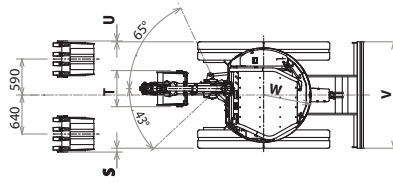
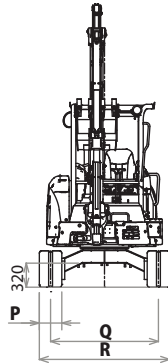

## Specifications

Model		Vi035-6A	
Type		Canopy	Cabin
<b>Operating Weight</b>	Rubber track	7905 (3585) lbs (kg)	8214 (3725) lbs (kg)
	Steel track	8125 (368) lbs (kg)	8434 (3825) lbs (kg)
<b>Engine</b>	Type	Water-cooled 4-cycle diesel	
	Model	3TNV88F-ESBV	
	Rated Output	24.4 (18.2) / 2200 HP (kW)/rpm	
<b>Performance</b>	Max Digging Force, Bucket / Arm	w/ QC - 5643 (25.1); w/o QC - 7216 (32.1) lbs (kN)	
	Traveling Speed, High / Low	2.7 (4.5) / 1.6 (2.7) MPH (km / h)	
	Swing Speed	9.5 RPM	
	Boom Swing Angle, (L / R)	43 / 65 degrees	
<b>Ground Contact Pressure (Rubber Track)</b>	PSI (kPa)	4.80 (33.1)	4.97 (34.3)
<b>Hydraulic System</b>	Pump Capacity	9.8 (37.0)x2 <Variable displacement pump>	
	Main Relief Set Pressure	6.9 (26.2)x1, 2.9 (10.8)x1 <Gear pump>	
<b>Blade Dimensions</b>	Width	5' 8" (1740) ft-in (mm)	
	Stroke, Raise / Lower from G.L.	1' 5" (425) / 1' 3" (370) ft-in (mm)	
<b>Fuel tank capacity</b>	Gals (L)	10.8 (41)	

## Standard Equipment

- Hydraulic Quick Coupler\*
- Backfill Dozer Blade
- Boom Swing Function
- Rubber Track / Steel Track
- Auxiliary Valve and Plumbing
- Back Mirror
- 2-way Control Pattern Change
- ROPS / OPG Canopy, Cabin
- Windshield Washer
- Joystick Pilot Controls
- Arm Rests (Adjustable)
- Suspension and Reclining Seat
- Seat Belt
- Proportional Auxiliary Hydraulics Control
- Travel Automatic
- Dual Speed Switch
- Auto Deceleration Switch
- Eco Mode Switch
- Engine Stop Switch
- Traveling Alarm
- Floor Mats

\*Also available without Quick Coupler.

Please note that the standard equipment may vary from this list. Consult your Yanmar dealer for confirmation.

## Hydraulic PTO

Model	Vi035-6A		
	Output	PSI (MPa)	GPM (L / min)
			2200RPM
<b>Combined Flow, Double Actions</b>	3205 (22.1)	16.7 (63.2)	8.35 (31.6)

## Lifting Capacity

LIFT POINT HEIGHT h:in (mm)	r:REACH in (mm)											
	RATED LIFT CAPACITY OVER END BLADE DOWN				RATED LIFT CAPACITY OVER END BLADE UP				RATED LIFT CAPACITY OVER SIDE BLADE UP			
	MAX	137.8(3500)	118.1(3000)	98.5(2500)	MAX	137.8(3500)	118.1(3000)	98.5(2500)	MAX	137.8(3500)	118.1(3000)	98.5(2500)
118.1 (3000)	*1719(780)	*1631(740)	*1609(730)		1058(480)	1322(600)	*1565(710)		992(450)	1278(580)	*1565(710)	
78.7 (2000)	*1763(800)	*1918(870)	*2138(970)	*2491(1130)	903(410)	1278(580)	1653(750)	*2447(1110)	815(370)	1256(570)	1543(700)	*2447(1110)
39.4 (1000)	*1807(820)	*2336(1060)	*2888(1310)	*3813(1730)	793(360)	1190(540)	1521(690)	1984(900)	749(340)	1124(510)	1410(640)	1807(820)
Ground (0)	*1873(850)	*2601(1180)	*3218(1460)	*4012(1820)	815(370)	1124(510)	1410(640)	1873(850)	793(360)	1058(480)	1322(600)	1719(780)
-39.4 (-1000)	*1940(880)	*2403(1090)	*2954(1340)	*3703(1680)	925(420)	1080(490)	1388(630)	1851(840)	881(400)	1014(460)	1322(600)	1675(760)
-59.1 (-1500)	*1918(870)	*2050(930)	*2579(1170)	*3130(1420)	1124(510)	1080(490)	1410(640)	1851(840)	1058(480)	1058(480)	1344(610)	1675(760)
-78.7 (-2000)	*1851(840)				1477(670)				1410(640)			

o : h m i m u m l o d s m r k d i h n s r r i s k (\*) r l i m i d b h r o s h d r u l i l i n g i r h r h b i s s i l d d ( i n g o ) i .