

TS-324
Roof System
Seaming
Guide

SCHULTE BUILDING SYSTEMS
Headquarters/Texas Plant
17600 Badtke Road
Hockley, Texas 77447
7.844.258.BLDG Toll Free
Phone: 281.304.6111
Fax: 281.304.6113

Hueytown, Alabama Plant
3387 Davey Allison Blvd.
PO Box 3160
Hueytown, AL 35023
1.877.887.4247 Toll Free
Phone: 205.744.1561
Fax: 205.744.1562



INDEX

1.0 GENERAL	1	8.0 BEFORE OPERATING THE MOTOR SEAMING MACHINE	
2.0 SEAM TYPES		8.1 Seaming Machine Nomenclature	13
2.1 General	3	8.2 Check Seaming Rolls	13
2.2 RollLok™ Seam	3	8.3 Check Locking Pressure	14
2.3 TripleLok™ Seam	3	8.4 Clean the Seams	14
2.4 QuadLok™ Seam	3	8.5 Starting Seams	14
3.0 IMPORTANCE OF SEAMING		9.1 MOTOR SEAMING MACHINE OPERATION	
3.1 Roof Performance	4	9.1 Machine Orientation to Seam	15
3.2 When to Seam	4	9.2 Machine Position on Roof Panel	15
3.3 Temporary Seaming	4	9.3 Locking the Machine to the Seam	16
4.0 SEAMING EQUIPMENT		9.4 Running the Machine	17
4.1 Specialized Seaming Tools	5	9.5 Stopping the Machine	17
4.2 Seaming Tool Source	5	9.6 Un-locking the Machine	17
4.3 Seaming Kit	5	9.7 Checking the Finished Seam	17
4.4 Receiving and Shipping	6	10.0 MOTOR SEAMING MACHINE MAINTENANCE	
4.5 Handling and Storage	6	10.1 General	18
4.6 Insurance	6	10.2 Seaming Rolls	18
5.0 ELECTRICAL REQUIREMENTS		10.3 Lubrication	18
5.1 Motor Seaming Machine	7	10.4 Cooling Vents	18
5.2 Electrical Service and Cords	7	11.0 RollLok™ SEAMING	
5.3 Electrical Safety	7	11.1 Manual Seaming	19
5.4 Cord Clearance	7	11.2 Finish Seam Detail	19
6.0 CHECK PANEL ASSEMBLY		12.0 TripleLok™ SEAMING	
6.1 Sidelap Fit-up	8	12.1 Manual Seaming	20
6.2 Clip Alignment	8	12.2 Motor Seaming	20
6.3 Seam Damage	8	12.3 Finished Seam Detail	20
7.0 MANUAL SEAMING TOOL OPERATION		13.0 QuadLok™ SEAMING	
7.1 Manual Seaming Tool Nomenclature	9	13.1 Prior Seaming	21
7.2 Assemble Seaming Tool	9	13.2 Motor Seaming	21
7.3 Tool Orientation to Seam	9	13.3 Finished Seam Detail	21
7.4 Forming the Seam	10		
7.5 Tool Position at End of Roof Panel	11		
7.6 Tool Position at Roof Panel Endlap	11		
7.7 Tool Position at Panel Clips	12		
7.8 Checking the Finished Seam	12		

1.0 GENERAL

The seaming guide is provided to Schulte Building Systems' customers and erectors as the recommended procedures for the correct seaming of the TS-324™ Standing Seam Roof System.

This guide is intended to be used with the TS-324™ Standing Seam Roof System Installation Guide and the project's erection drawings.

The erection drawings govern the specific seam requirements. In case of conflict between this installation guide and the erection drawings, the erection drawings will have precedence.

The customer is responsible for proper seaming of the roof in accordance with the erection drawings and this seaming guide, and in accordance with good engineering and construction practices.

The customer must take the responsibility for selecting a competent erector, insist that the work be performed by

qualified and experienced standing seam metal roof installers, insist that the erector take time to study and understand this guide, then assure that the erector correctly follows the guide's instructions.

Schulte Building Systems does not guarantee and is not liable for the quality of erection and is not responsible for building defects that may be attributed to improper erection or the negligence of other parties.

Clarification concerning the TS-324™ roof installation and seaming should be directed to the SBS Customer Service Manager.

SCHULTE BUILDING SYSTEMS

17600 Badtke Road
Hockley, Texas 77447
Phone: 281.304.6111
Fax: 281.304.6113

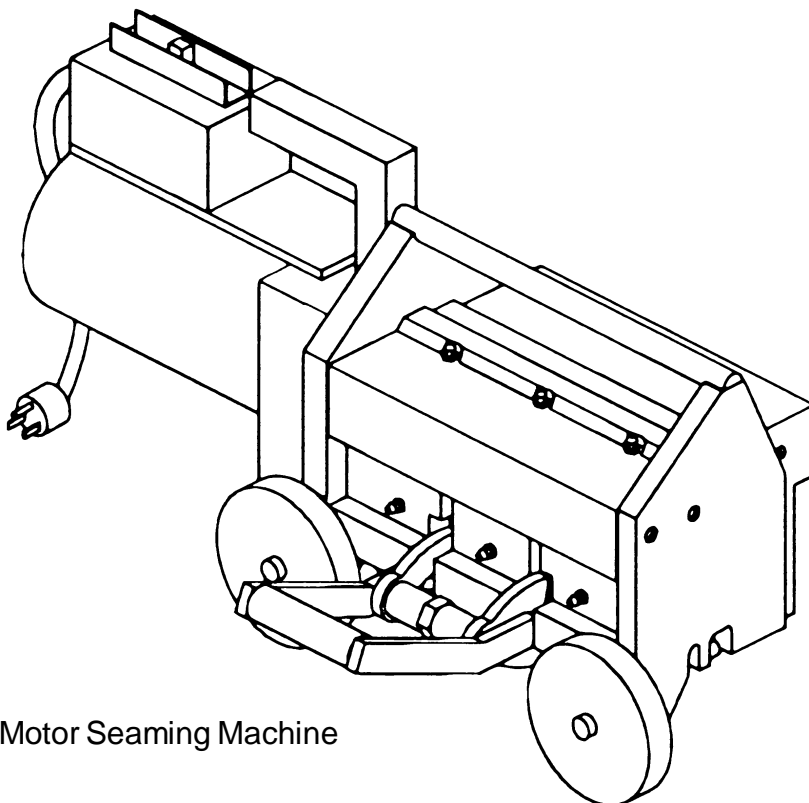

Motor Seaming Machine

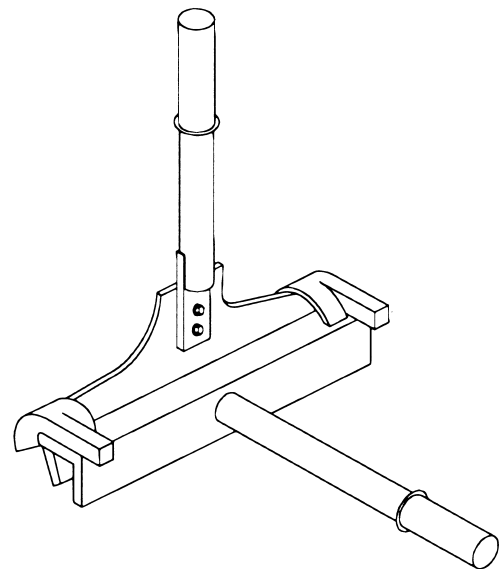

Manual Seaming Tool

2.0 SEAM TYPES

2.1 General

The TS-324™ Standing Seam Roof System has three seam type options. The project's design and roof performance requirements govern which seam type is required.

Different seam types may be required on specific areas of the roof. In all cases, refer to the erection drawings to determine the required seam type and location.

2.2 RollLok™ Seam

The RollLok Seam requires seaming the roof panels with the manual seaming tool only at the panel clips, at the eave and ridge ends of the roof panel, and at the endlaps.

The motor seaming machine is not required for RollLok seaming.

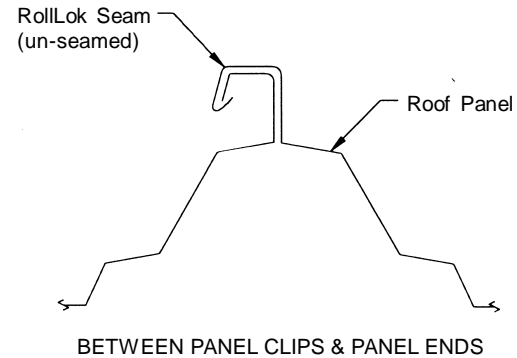
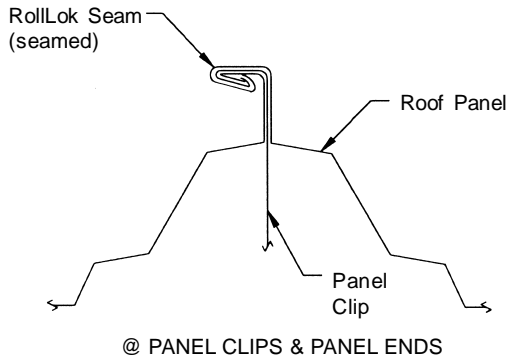

2.3 TripleLok™ Seam

The TripleLok Seam requires seaming the roof panel with the manual seaming tool at the starting eave or ridge end of the roof panel and at the endlaps. Then seaming the full length of the roof panels with the motor seaming machine.

The motor seaming machine must be fitted with the TripleLok seaming rolls.

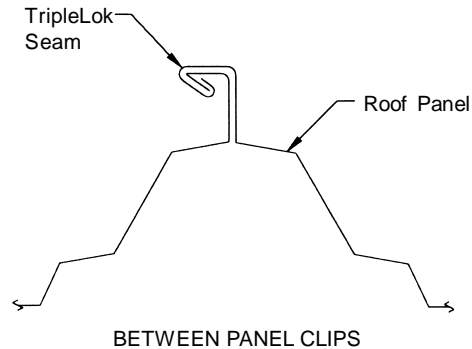
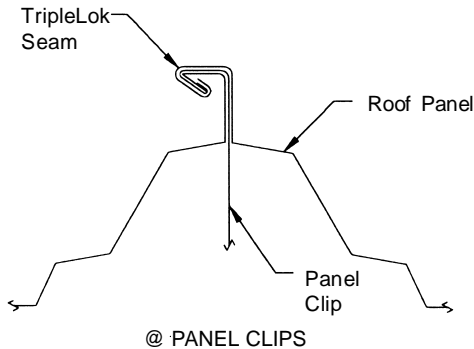

2.4 QuadLok™ Seam

The QuadLok Seam requires that the roof panels be previously TripleLok seamed. Then re-seaming specified areas of the roof with the motor seaming machine.

The motor seaming machine must be fitted with the QuadLok seaming rolls.

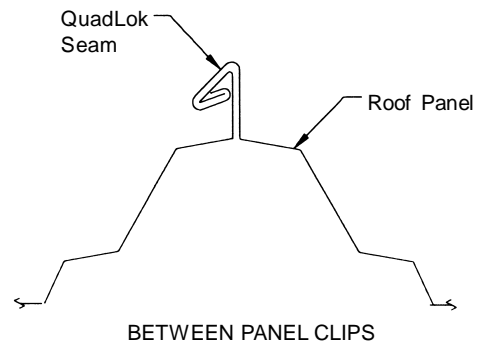
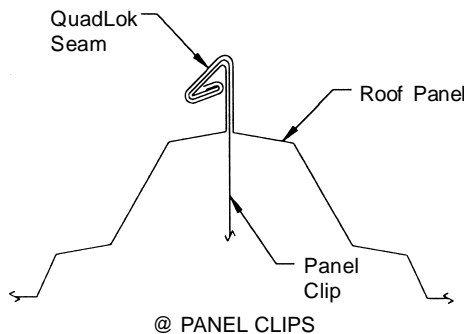

3.0 IMPORTANCE OF SEAMING

3.1 Roof Performance

The roof panels must be correctly seamed before the roof system can provide its designed wind load and weather resistance capability. This means that an un-seamed roof is subject to wind load failure and/or weather resistance failure.

3.2 When to Seam

Whenever possible, the installed roof panels should be seamed at the finish of each days work. If high wind or rain/snow conditions are imminent, the installed roof panels must be seamed before such conditions occur.

3.3 Temporary Seaming

On roofs requiring TripleLok and QuadLok seams, it may not always be practical or feasible to motor seam the roof panels until after the roof installation is completed. Motor seamed roof panels are difficult to reposition or replace and seaming machines may not always be available during the entire roof installation period.

In such cases, it may be desirable to temporarily RollLok seam the roof panels with the manual seaming tool, then later complete the seaming with the motor seaming machine.

Important: Temporary RollLok seaming must be approved by the project's designer.

4.0 SEAMING EQUIPMENT

4.1 Specialized Seaming Tools

The seaming of the TS-324™ roof panels require special seaming tools which are available only from the Schulte Building Systems.

Caution: The use of other seaming equipment may result in faulty and/or damaged seams and may invalidate the roof system's material and performance warranties.

4.2 Seaming Tool Source

The seaming tools are provided by Schulte Building Systems in accordance to the terms and conditions of the rental or purchase contract. Contact the Schulte Building Systems Customer Service Department to arrange the scheduling, delivery and return of the seaming tools.

4.3 Seaming Kit

The seaming equipment will normally be provided as a seaming kit. The seaming kit will consist of the following:

- a. Seaming Kit Chest (contains and protects the seaming tools during shipment and storage).
- b. Motor Seaming Machine (provided only for TripleLok or QuadLok seaming)
- c. Return shipping documents

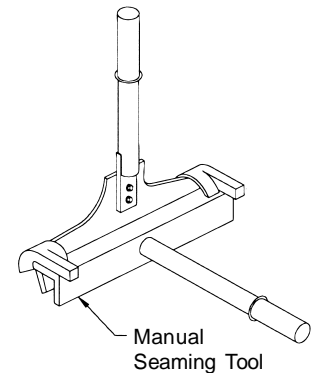
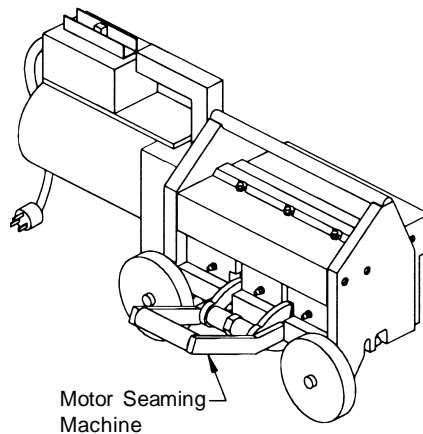
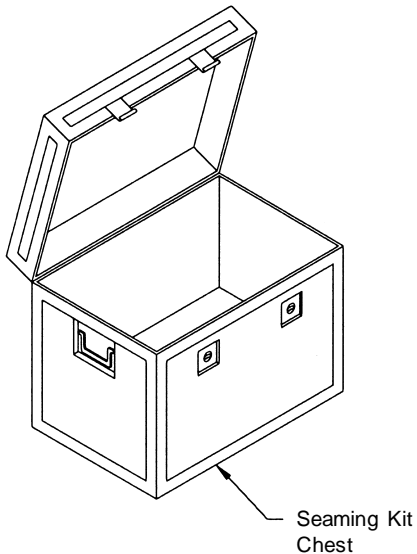

4.0 SEAMING EQUIPMENT (Cont'd.)

4.4 Receiving and Shipping

Upon receipt of the seaming kit, and before signing the shipping receipt, check and verify that the seaming kit is received in good condition without damage or loss of contents.

If there is damage or loss of contents, immediately file the claim with the shipper and notify Schulte Building Systems for replacement instructions.

Upon completion of the roof seaming, promptly return the seaming kit to Schulte Building Systems in accordance with the instructions on the return shipping documents. The return shipping documents are provided in the seaming kit.

4.5 Handling and Storage

Provide safe and secure handling of the seaming tools when in use.

The motor seaming machine weighs 65 lbs. and can cause severe damage and injury if it falls.

The machine may be too heavy to safely carry up a ladder. Always hoist the machine onto the roof with proper lifting equipment or with a proper sized rope tied or hooked securely to the machine's front lifting handle.

When starting and finishing the seaming machine at the edges of the roof, the operator must be securely positioned so that he can safely lift the seaming machine on and off of the seam.

Caution: When running the machine in the downslope direction, the seaming machine will have greater downhill inertia and coasting distance.

When not locked to the seam, the motor seaming machine can freely roll on its wheels. Always secure the machine to prevent its rolling or sliding off the roof.

When the seaming tools are not in use, they must be stored in the seaming kit chest and the chest secured in a safe and dry area. The seaming tools must be cleaned and dried before storing.

4.6 Insurance

The TS-324™ Roof System seaming tools are custom built, specialized equipment and are costly to replace. Provide adequate insurance coverage on the seaming tools while they are in your possession and use.

5.0 ELECTRICAL REQUIREMENTS

5.1 Motor Seaming Machine

The seaming machine motor requires a minimum electrical power supply of 20 amp @ 120 Volt @ 60 hz AC.

5.2 Electrical Service and Cords

The electrical service and the electrical cords to the seaming machine must be of sufficient capacity to provide the full 20 amp @ 120 Volts **at the seaming machine**. If other tools or equipment are being used on the same service, the service and cord capacity must be increased accordingly.

Caution: Low voltage due to insufficient service capacity, insufficient cord size or excessive cord length will cause overheating and burnout of the seaming machine's motor.

5.3 Electrical Safety

Check that the power cords are fitted with the correct plug for safe and secure electrical connection to the seaming machine. Check that the power cords are properly grounded and that the service has a ground fault circuit breaker.

5.4 Cord Clearance

Check that the electrical cord is of sufficient length to extend the full length of the area to be seamed without stress on the cord or its connections. Check that the path for the cord is clear and that the cord is clear of snagging on panel edges or entanglement into the seaming machine rolls.

6.0 CHECK PANEL ASSEMBLY

6.1 Sidelap Fit-up

Before seaming, inspect the full length of each roof panel sidelap. Check that the male and female are fully nested and the lip at the panel's male edge is enclosed by the hook of the adjacent panel's female edge.

Any conditions where the male and female are not fully nested or the male lip is not positioned inside of the female hook must be corrected before attempting to seam the roof panels.

Caution: Faulty seaming may occur where the male lip is not enclosed by the female hook and when the male and female are not fully nested. Such faulty seaming can result in seaming difficulty and objectionable seam appearance. In severe cases reduction in roof performance specifications..

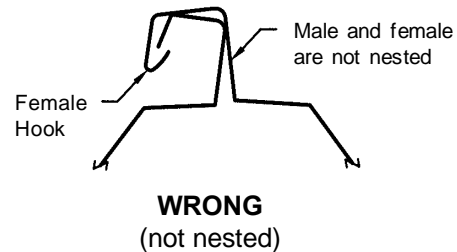
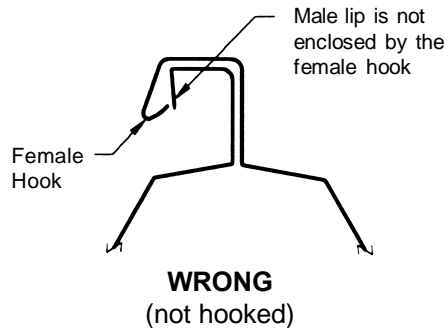
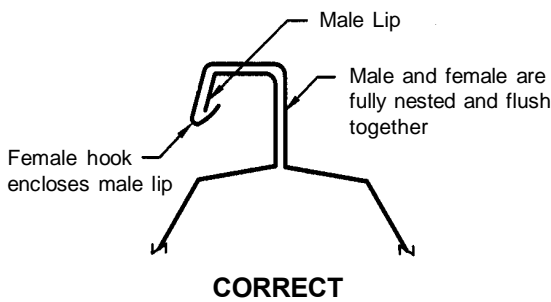

6.2 Clip Alignment

Before seaming, check that each roof panel clip is properly seated in the roof panel sidelap assembly. Any displaced clips must be corrected before attempting to seam the roof panels.

Caution: Misaligned panel clips can cause faulty seaming and objectionable seam appearance.

6.3 Seam Damage

Before seaming, check that the male and female edges are not kinked or otherwise distorted. Any such distortions must be corrected before attempting to seam the roof panels.

7.0 MANUAL SEAMING TOOL OPERATION

7.1 Manual Seaming Tool Nomenclature

The following detail identifies the operational parts of the manual seaming tool.

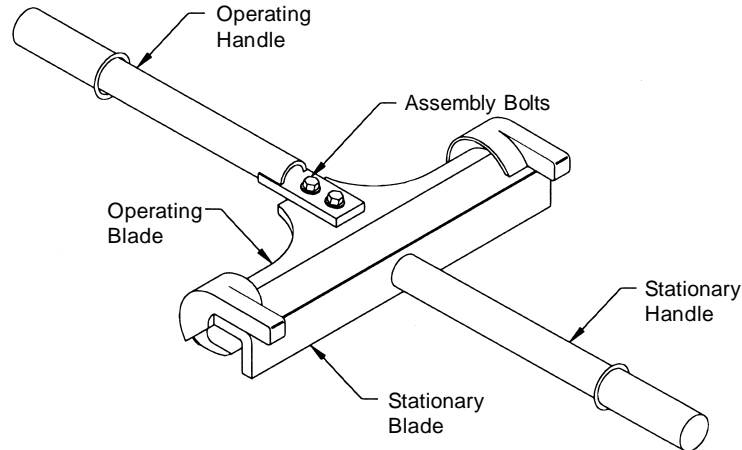

7.2 Assemble Seaming Tool

When received, the manual seaming tool may be disassembled. Assemble the handle to the tool body and secure with the provided bolts.

7.3 Tool Orientation to Seam

Orient the tool to fit correctly onto the roof panel seam as shown. The stationary handle must be in the horizontal position and the operating handle must be rotated up to the open position.

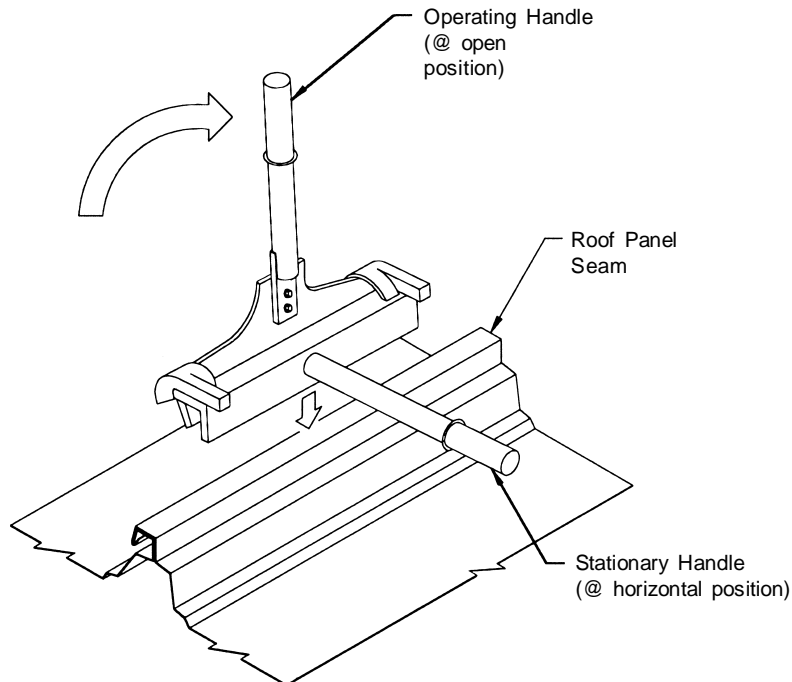

7.0 MANUAL SEAMING TOOL OPERATION (Cont'd.)

7.4 Forming the Seam

When the tool is correctly positioned on the panel, push the stationary blade down solidly against the top of the seam.

While holding the stationary handle in the horizontal position, rotate the operating handle down to the horizontal position. This will form the seam.

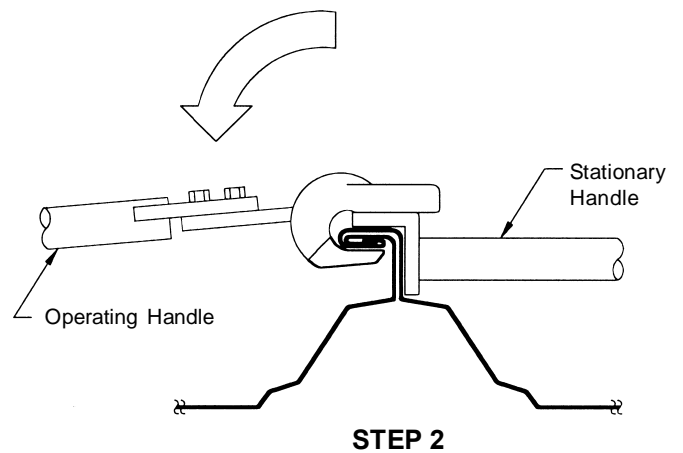
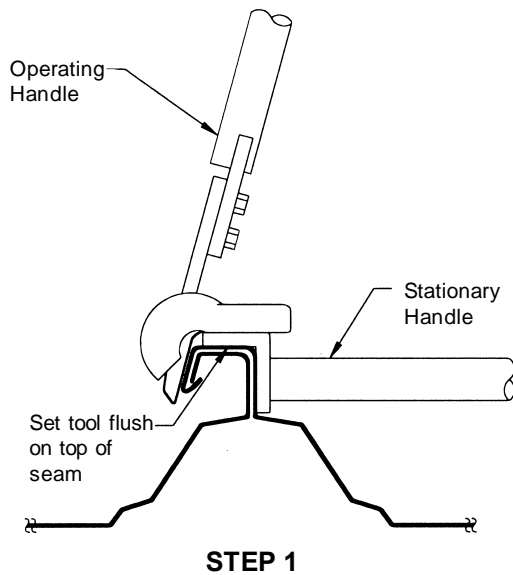
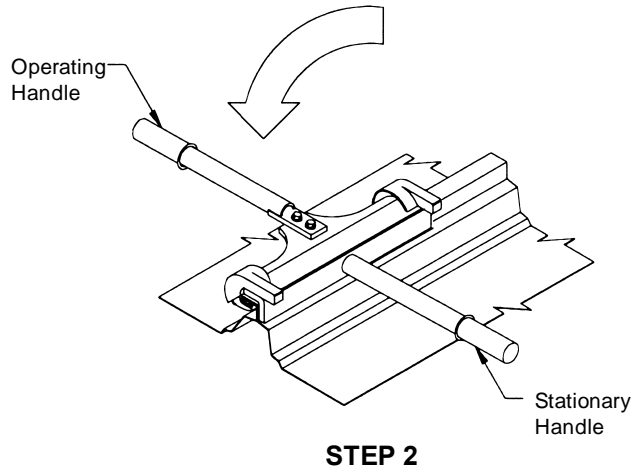
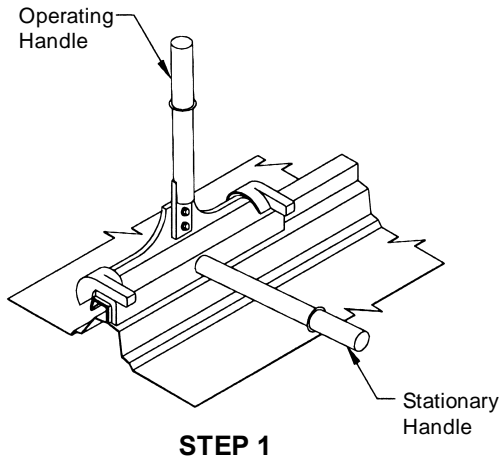

7.0 MANUAL SEAMING TOOL OPERATION (Cont'd.)

7.5 Tool Position at End of Roof Panel

When seaming at the eave or ridge end of the roof panel, the seaming must be done in two steps.

For the second step, position the end of the seaming tool flush with the end of the roof panel and seam that area.

For the first step, position the end of the seaming tool at 6" from the end of the roof panel and seam that area.

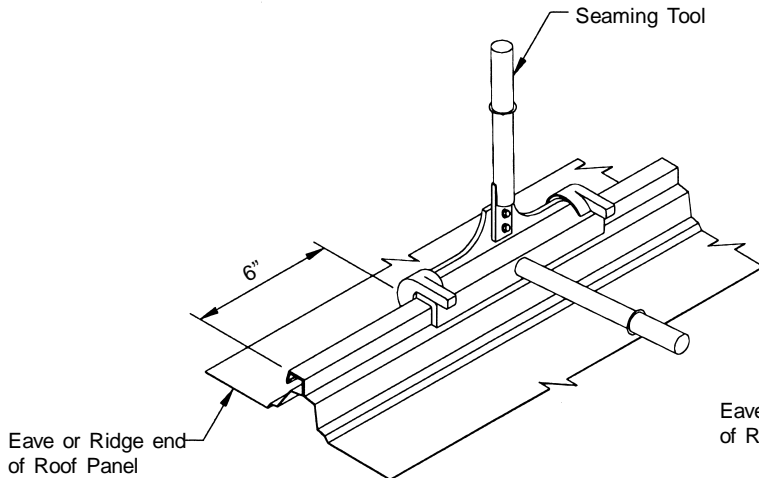

STEP 1

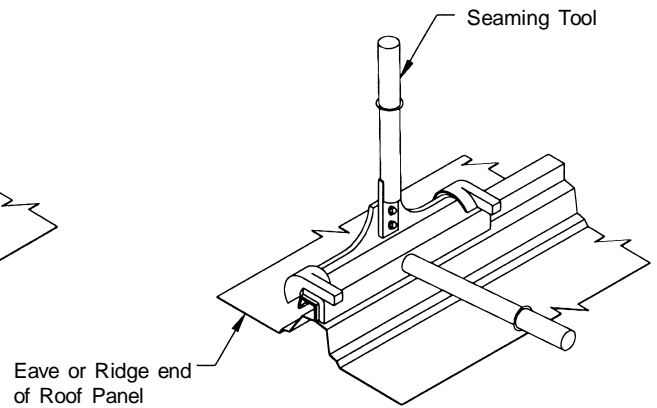

STEP 2

7.6 Tool Position at Roof Panel Endlap

When seaming at a roof panel endlap, the seaming must be done in two steps.

For the second step, position the end of the tool 3" uphill from the edge of the endlap and seam that area.

For the first step, center the tool over the endlap and seam that area.

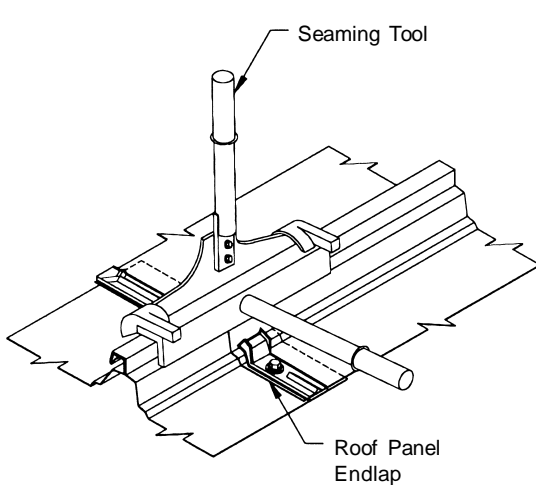

STEP 1

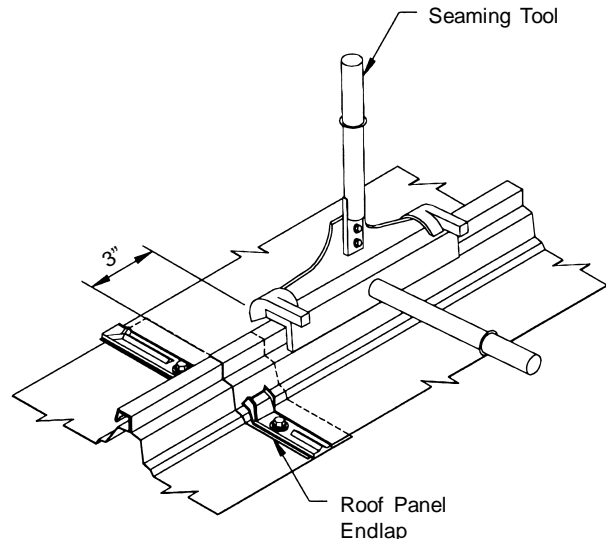

STEP 2

7.0 MANUAL SEAMING TOOL OPERATION (Cont'd.)

7.7 Tool Position at Panel Clips

When seaming at a panel clip location, center the tool over the panel clip and seam that area.

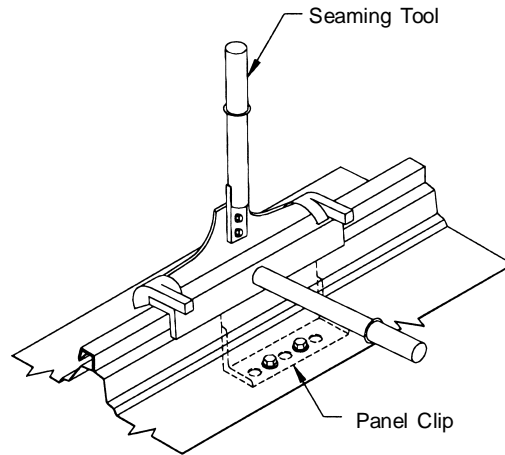

@ PANEL CLIPS

7.8 Checking the Finished Seam

Rotate the operating handle to the open position, remove the tool and check that the seam is correctly formed, as shown on the detail below.

Caution: If the manual seaming tool does not correctly form the seam, do not continue seaming but contact Schulte Building Systems for instructions.

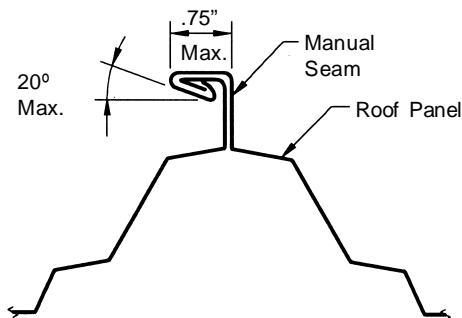

8.0 BEFORE OPERATING THE MOTOR SEAMING MACHINE

8.1 Seaming Machine Nomenclature

The following details identify the operational parts of the motor seaming machine.

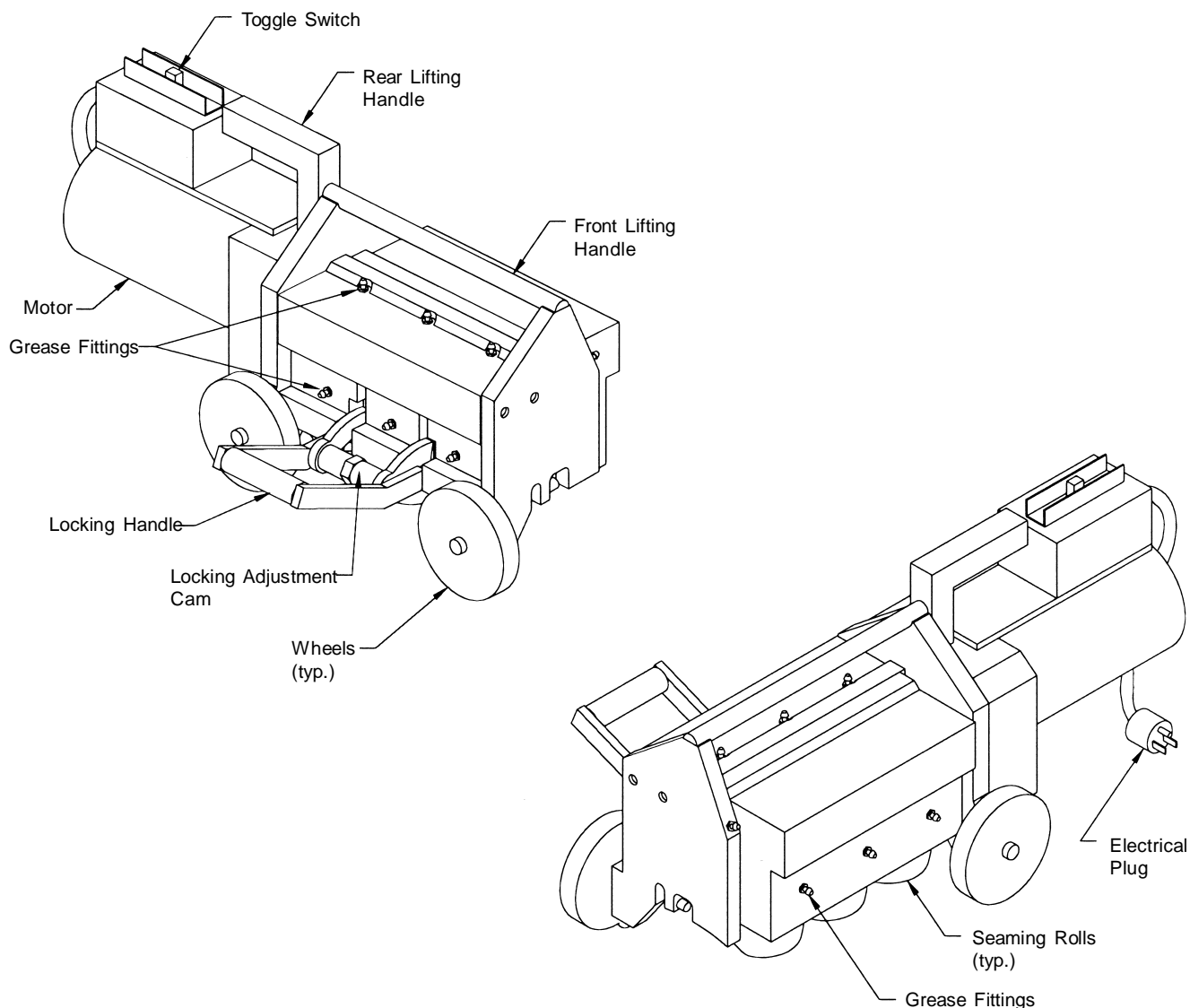

8.2 Check Seaming Rolls

Check that the seaming machine is correctly set-up for the required seam.

Turn the machine on its side so that the stamped numbers on the bottom surface of the forming rolls can be read. There are two rows of rolls. One row is the three forming rolls. The other row is the three backer rolls.

For TripleLok seaming, the forming rolls must be stamped 1F-TS, 2F-TS & 3F-TS (or 3F-TS-22 if the roof panel is 22 gage).

For QuadLok seaming, the forming rolls must be stamped 4F-TS (or 4F-TS-22 if the roof panels are 22 gage), 5F-TS & 6F-TS.

For both TripleLok and QuadLok seaming, the backer rolls must be stamped 1B-TS, 2B-TS & 3B-TS.

8.0 BEFORE OPERATING THE MOTOR SEAMING MACHINE (Cont'd.)

8.3 Check Locking Pressure

To correctly form the seams, the seaming machine must exert the proper locking pressure on the forming rolls.

Before operating the seaming machine, and frequently during seaming, check the locking pressure per the following instructions.

With the machine **not** setting on a roof panel seam, pull up the locking handle to the fully open position, then push the locking handle down as far as it will go. A force of 10 to 15 lbs. should be required to push the locking handle into the

locked position. The locking handle should “snap” into its locked position.

Important: If the locking pressure is less than 10 lbs. or the locking handle does not “snap” into a locked position, contact Schulte Building Systems for instructions.

Caution: Failure to maintain the proper locking pressure can result in faulty seaming and seams which may be objectionable in appearance.

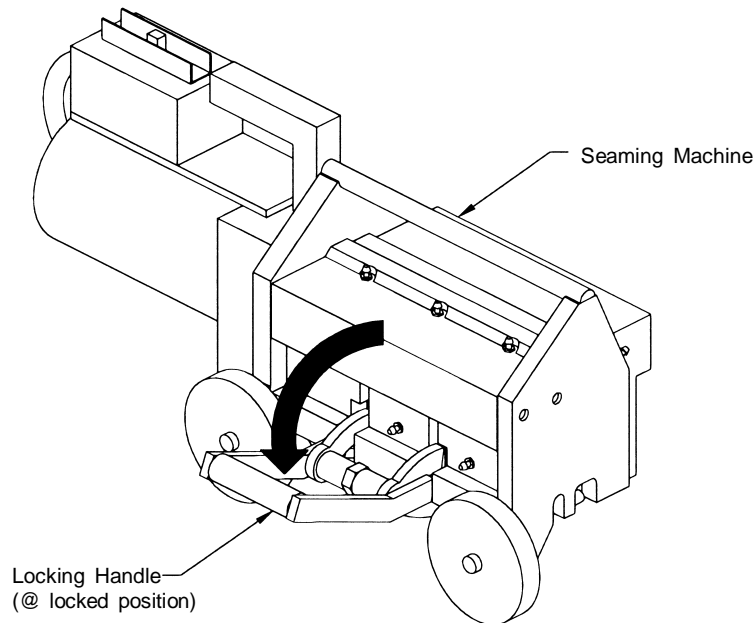

8.4 Clean the Seams

The roof panel seams must be thoroughly cleaned of abrasive dirt or dust that can cause scuffing or scratching of the seam surface. The roof panel seams must be cleaned of grease or other contaminants which can cause seaming machine slippage and marking of the seam surface.

8.5 Starting Seams

For TripleLok seaming, the seaming machine must start on a portion of seam which has already been seamed with the manual seaming tool. Depending on which direction the seaming machine will be run, form the starting seam at the eave or ridge end of the roof panels with the manual seaming tool as described in section 7.4.

9.0 MOTOR SEAMING MACHINE OPERATION

9.1 Machine Orientation to Seam

On roofs sheeted from left to right, the seaming machine will run from the eave to the ridge. On roofs sheeted from right to left, the seaming machine will run from the ridge to the eave.

As the seaming machine travels along the roof panel seam, the seaming machine's motor is always at the rear.

9.2 Machine Position on Roof Panel

With the locking handle held up in the open position, set the seaming machine onto the starting end of the roof panel's seam over the manually seamed portion of the seam.

Roll the seaming machine forward to align the front seaming rolls over the un-seamed portion of the seam as shown in the detail below.

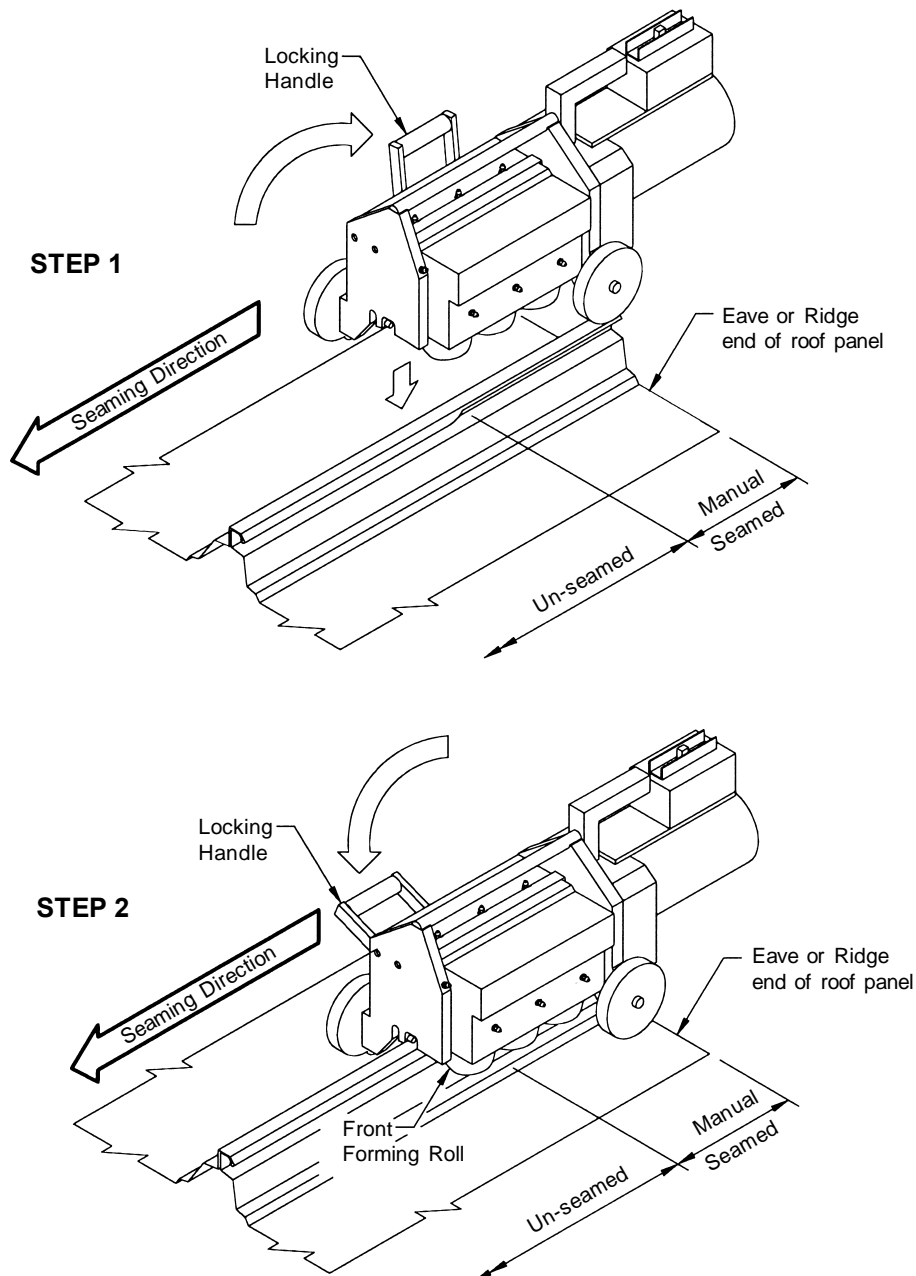

9.0 MOTOR SEAMING MACHINE OPERATION (Cont'd.)

9.3 Locking the Machine to the Seam

When the machine is in the correct position on the seam, push the locking handle down to the locked position. The locking handle should lock when 25 to 30 lbs. of downward force is applied.

Check that the seaming rolls are properly engaged on the seam as shown in the details below.

If the locking handle will not readily lock, roll the machine forward or backward slightly until a position is found where the locking handle will readily lock.

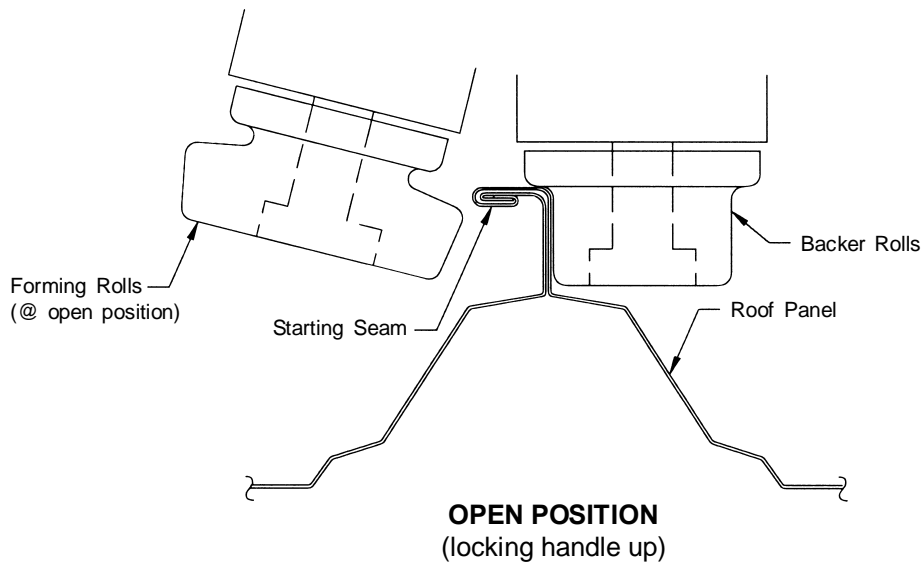

* When in the locked position, the rolls must be in contact with the panel. There must be no gaps or looseness between the rolls and the panel.

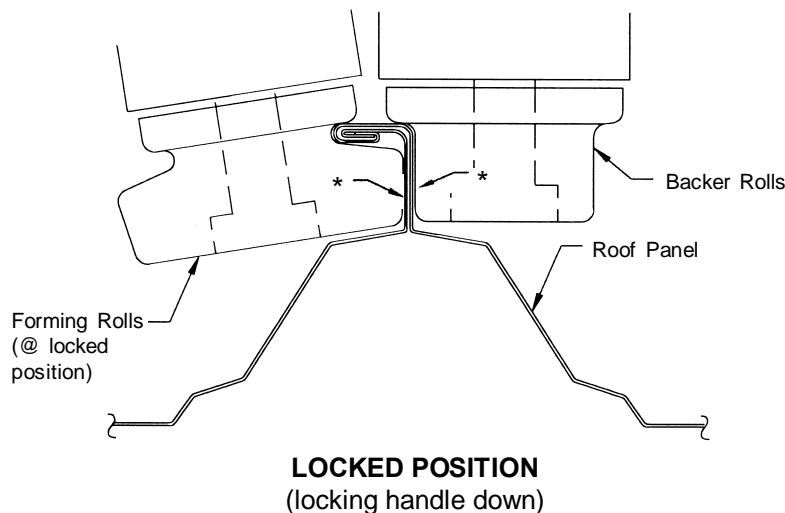

9.0 MOTOR SEAMING MACHINE OPERATION (Cont'd.)

9.4 Running the Machine

Check that the machine's path is clear of power cords, tools, debris etc.

Start the machine by turning on the machine's toggle switch.

Watch the machine and finished seam carefully for any indications of machine malfunction or faulty seaming.

Caution: The seaming machine must always be in the vertical position while seaming. Do not allow the machine to tilt sideways when locking the machine onto the seam or while the machine is running. On roofs with high stand-off clips, walking or standing on the panel next to the machine can deflect the panel and cause the machine to tilt. Do not walk or stand on the panel next to the machine while it is running.

9.5 Stopping the Machine

Stop the machine by turning off the machine's toggle switch.

Always allow sufficient space for the machine to coast after turning the machine off.

Do not run the machine into previously installed end dams or other obstructions.

Caution: Stop the machine immediately and investigate any indications of machine malfunction or faulty seaming.

If the machine does not correctly form the seam, so not continue seaming but call Schulte Building Systems for instructions.

9.6 Un-locking the Machine

After the machine is turned off and has fully stopped, lift up the locking handle to the open position to un-lock the machine from the seam.

While holding up the locking handle, the machine can be lifted from the seam.

If the machine must be stopped and removed before completing the seam, use a felt marker to mark the position of the machine's front wheel on the panel. The machine can later be repositioned on the mark to complete the seaming.

9.7 Checking the Finished Seam

At the completion of each seam, check the full length of the seam for any indications of faulty seaming. Refer to section 11.3 and 12.3 for details of the correctly formed finished seam.

The seaming operation exerts high pressure bending forces on the seam. Under such conditions, minor burnishing, pressure marks, and black oxide marking of the seam surface is normal.

Caution: Black oxide marking is often mistaken to be damage of the seam surface. Objectionable black oxide can be removed with mild cleaning solutions or solvents.

10.0 MOTOR SEAMING MACHINE MAINTENANCE

10.1 General

The motor seaming machine is a precision fabricated, high performance, portable roll forming machine. This relatively lightweight machine does the tough job of forming the extra strong TripleLok and QuadLok seams under often rugged field conditions.

Although designed for tough industrial use, the seaming machine requires proper maintenance to assure proper seaming and efficient, trouble free operation.

Caution: Failure to properly maintain the seaming machine as instructed below can result in faulty or damaged seams and costly break-down of the seaming machine.

10.2 Seaming Rolls

The seaming rolls require the following regular maintenance:

- a. Assure that the seaming machine's seaming rolls are free of dirt, grease, sealant, etc.
- b. Spray the seaming rolls with WD-40 (or equal) to prevent corrosion and minimize Galvalume build-up on the rolls.
- c. Assure that the seaming machine's seaming rolls are tight on their shafts. Check and tighten the rolls' retainer screws as necessary.
- d. On painted roofs, especially during very hot or abrasive conditions, spraying or misting the seams

with water, or a light lubricant such as WD-40, ahead of the seaming machine may significantly reduce burnishing and oxide marking of the seam surface.

- e. On very dry Galvalume roofs, spraying or misting the seams with water, or a light lubricant such as WD-40, ahead of the seaming machine may significantly reduce seaming friction and Galvalume build-up on the seaming rolls.
- f. When QuadLok seaming, the increased seaming pressures may require spraying the seam with a light lubricant, such as WD-40, ahead of the seaming machine to reduce burnishing or abrasion of the seam surface.

10.3 Lubrication

Lubricate the seaming machine with EP2 grease (or equal) after every 10,000 sq. ft. of roof area is seamed (or every 5,000 sq. ft. if temperatures exceed 100° F.) Apply the grease at the (9) grease fittings on the top and sides of the seaming machine.

10.4 Cooling Vents

To prevent motor overheating, the motor has vents and an internal fan to provide a cooling air flow over the internal motor parts.

The cooling vents are located at the front and rear of the motor. At the front of the motor, the vents are the slots between the motor housing and the gear box. The rear vents are on the end of the motor housing. Check frequently

to assure that these vents are kept clean and clear of debris, stringing sealant, etc.

While the machine is running, never cover the machine or place it in a position where the cooling air flow to the vents will be restricted.

11.0 RollLok™ SEAMING

11.1 Manual Seaming

Along each roof panel seam, use the manual seaming tool to close the seam at the eave and ridge ends of the panels, at the panel endlaps and at each clip.

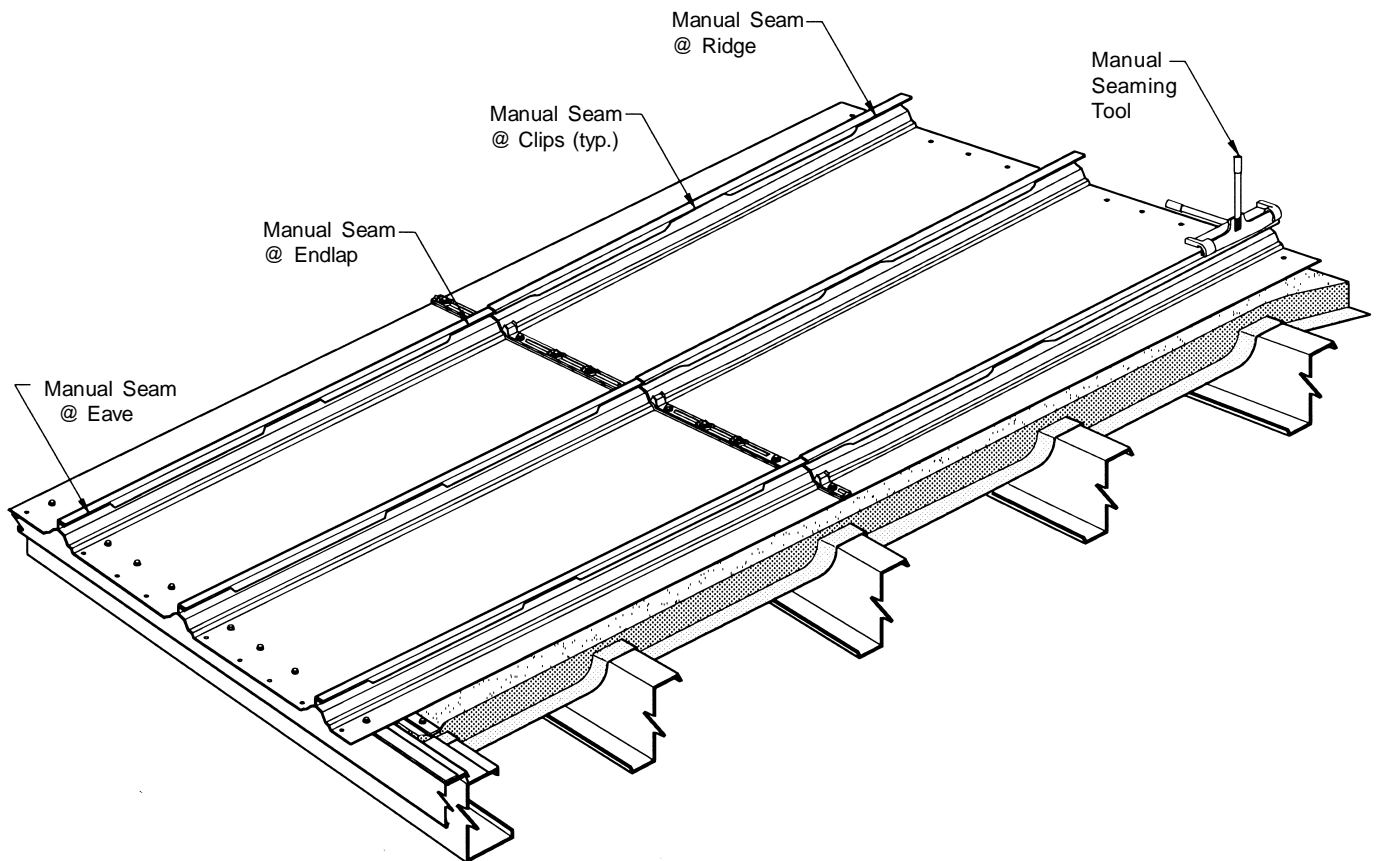

11.2 Finished Seam Detail

Check that the finished seam is correctly formed as shown in the following detail.

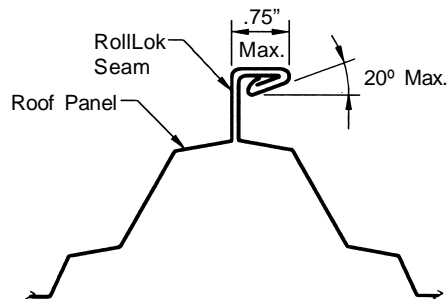

12.0 TripleLok™ SEAMING

12.1 Manual Seaming

Prior to motor seaming, use the manual seaming tool to seam the roof panels at the starting end of the seam (eave or ridge end, depending on seaming direction) and at the endlaps.

12.2 Motor Seaming

Seam the full length of each roof panel seam using the motor seaming machine which is fitted with the TripleLok forming rolls.

Start the seaming machine at the starting end of the seam, on the area previously seamed with the manual seaming tool.

If the roof panels have endlaps, stop the seaming machine just before running onto the endlap. Remove the seaming machine and restart it on the other side of the endlap on the area previously seamed with manual seaming tool.

Run the seaming machine to the finish end of the seams.

At any uncompleted seam areas, such as where the seaming machine had to be stopped prior to the endlap or ridge end dam, complete the seam with the manual seaming tool.

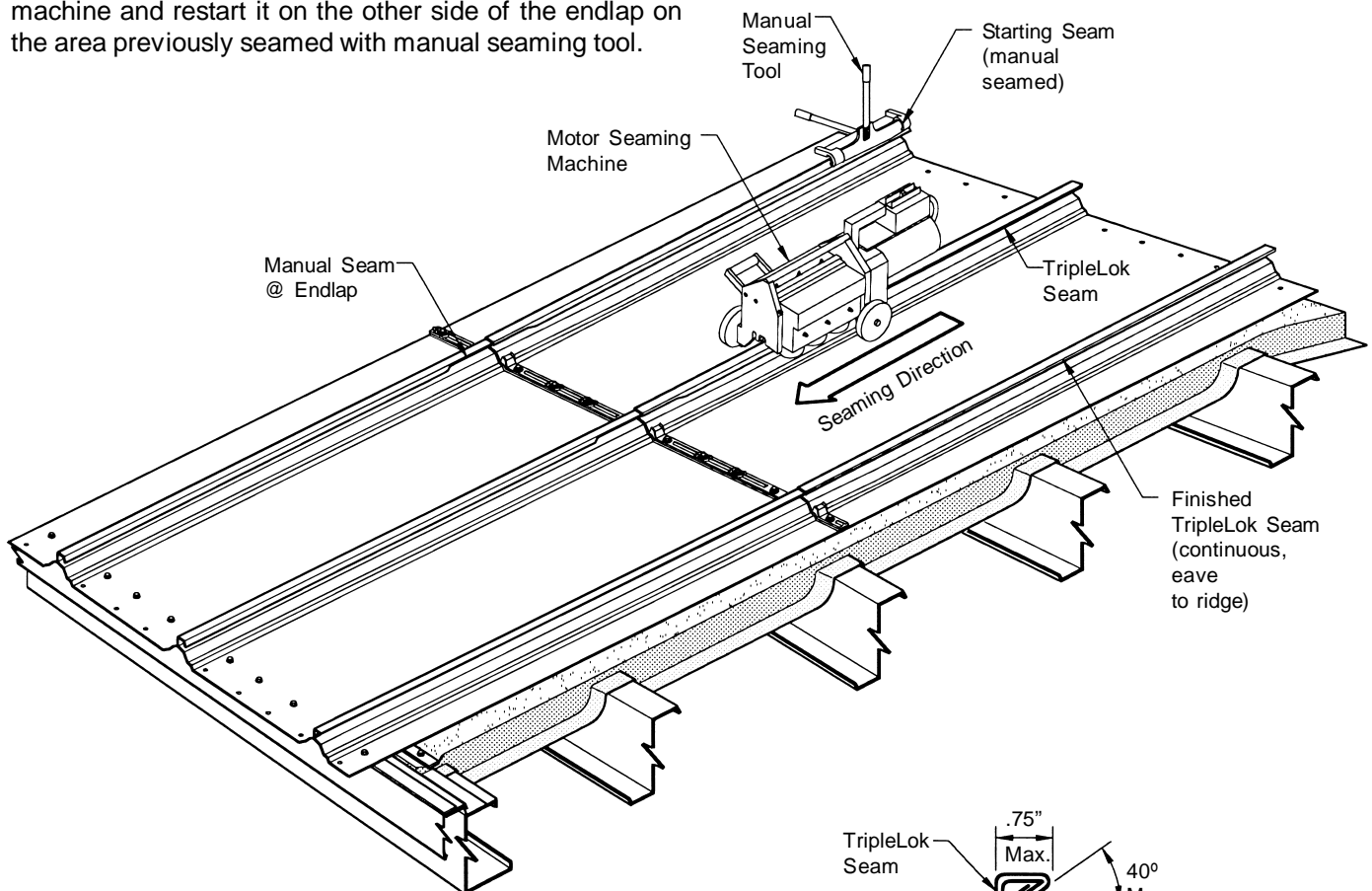

12.3 Finished Seam Detail

Check that the finished seam is correctly formed as shown in the detail at right.

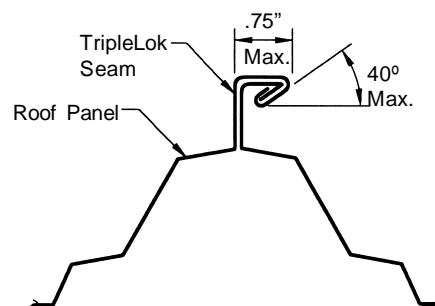

TS-324™ Roof System Seaming Guide

13.0 QuadLok™ SEAMING

13.1 Prior Seaming

Prior to QuadLok Seaming, the roof panels must have been fully TripleLok Seamed. Check that the TripleLok seams are correctly formed.

Caution: Attempting to QuadLok seam a faulty TripleLok seam can result in a faulty or damaged QuadLok seam. If the TripleLok seam is faulty, do not continue QuadLok seaming but contact Schulte Building Systems for instructions.

13.2 Motor Seaming

Seam the full length of each roof panel seam using the motor seaming machine which is fitted with the QuadLok forming rolls.

Start the seaming machine at the starting end of the seam (eave or ridge end, depending on seaming direction). Run the seaming machine to the finish end of the seams. The QuadLok seaming machine can be run over the endlaps.

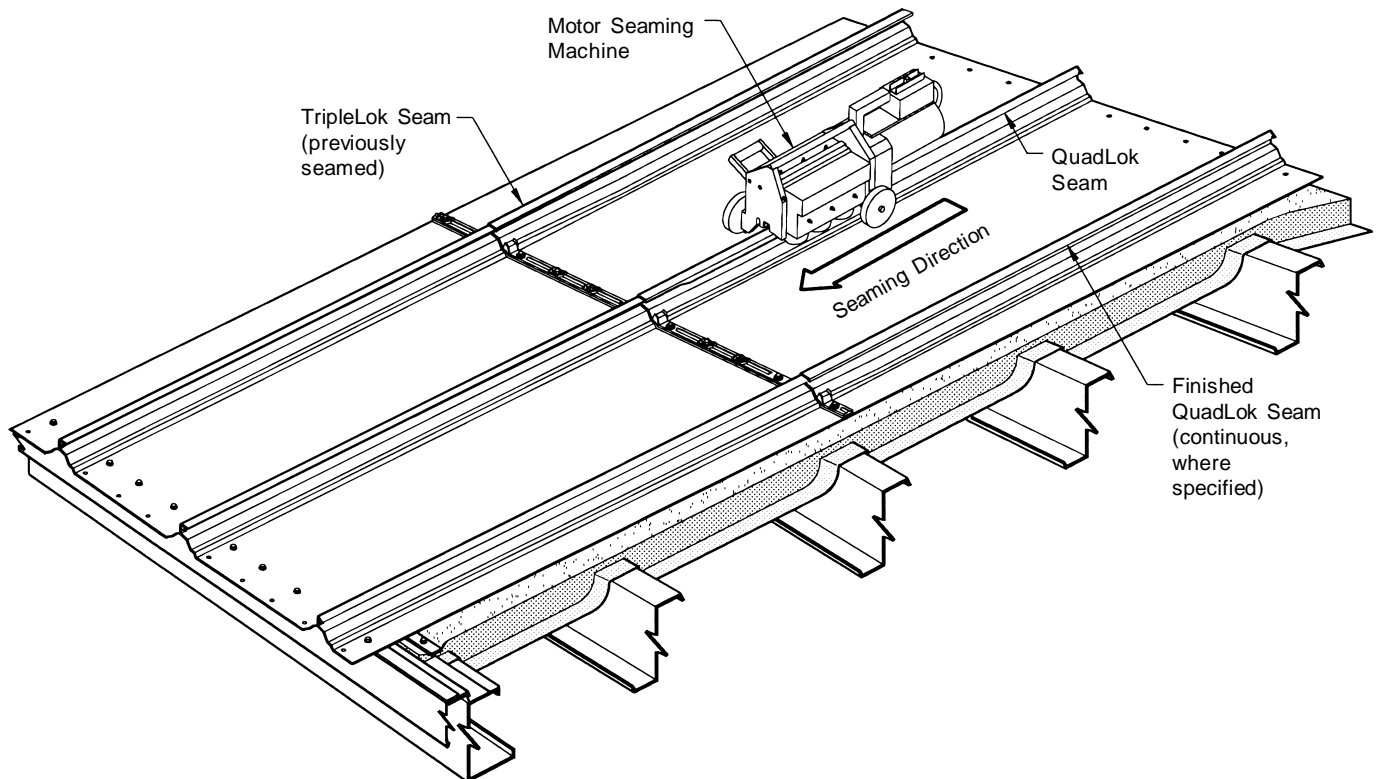

13.3 Finished Seam Detail

Check that the finished seam is correctly formed as shown in the detail at right.

