

TRANSMISSION FLUID LEVEL AND ...

TRANSMISSION FLUID LEVEL AND CONDITION CHECK (AUTOMATIC TRANSMISSION - 6T30/6T40/6T45/6T50)

Document ID#
2084511

Transmission Fluid Level and Condition Check

This procedure checks both the **transmission fluid** level, as well as the condition of the fluid itself.

Caution: Use Dexron VI transmission fluid only. Failure to use the proper fluid may result in transmission internal damage.

Note: Ensure the transmission has enough fluid in it to safely start the vehicle without damaging the transmission. With the vehicle off and the **transmission fluid** temperature at approximately 20–25°C (68–77°F) there must be at least enough fluid to drain out of the fluid level hole. This will ensure that there is enough fluid in the sump to fill the components once the vehicle is started.

Non Dipstick Level Checking Procedure

1. Start the engine.
2. Depress the brake pedal and move the shift lever through each gear range, pausing for about 3 seconds in each range. Then move the shift lever back to PARK (P).
3. Allow the engine to idle 500–800 rpm for at least 3 minutes to allow any fluid foaming to dissipate and the fluid level to stabilize. Release the brake pedal.

Note: If the TFT reading is not at the required temperature, allow the vehicle to cool, or operate the vehicle until the appropriate TFT is reached. If the fluid temperature is below the specified range, perform the following procedure to raise the fluid temperature to the specification.

Drive the vehicle in second gear until the fluid temperature is at the specified temperature.

4. Keep the engine running and observe the **transmission fluid** temperature (TFT) using the Driver Information Center or a scan tool.

Caution: The **transmission fluid** level must be checked when the **transmission fluid** temperature (TFT) is at 85–95°C (185–203°F). If the TFT is not at this temperature, operate the vehicle or allow the fluid to cool as required. Setting the fluid level with a TFT outside this temperature will result in either an under or over-filled transmission. TFT 95°C under-filled, TFT 85°C over-filled. An under-filled transmission will cause premature component wear or damage. An over-filled transmission will cause fluid to discharge out the vent tube, fluid foaming, or pump cavitation.

5. Raise the vehicle on a hoist. The vehicle must be level, with the engine running and the shift lever in the PARK range.

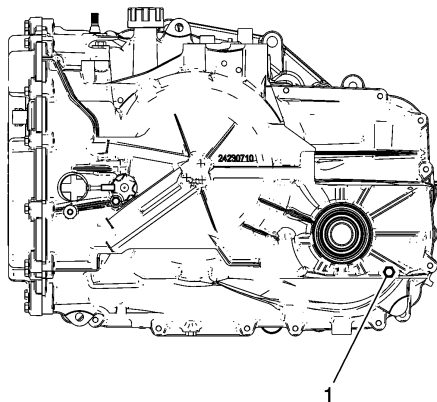

6. While the vehicle is idling, remove the oil level set plug. Allow any fluid to drain.

Oil Level Plug (1)

- If the fluid is flowing as a steady stream, wait until the fluid begins to drip.
- If no fluid comes out, add fluid until fluid drips out.

7. Inspect the fluid color. The fluid should be red or dark brown.

- If the fluid color is very dark or black and has a burnt odor, inspect the fluid for excessive metal particles or other debris. A small amount of "friction" material is a "normal" condition. If large pieces and/or metal particles are noted in the fluid, flush the oil cooler and cooler lines and overhaul the transmission. If there are no signs of transmission internal damage noted, replace the fluid, repair the oil cooler, and flush the cooler lines.

- Fluid that is cloudy or milky or appears to be contaminated with water indicates engine coolant or water contamination. Refer to [Engine Coolant/Water in Transmission](#).

8. Inspect for external leaks. Refer to [Fluid Leak Diagnosis](#).
9. If the fluid was changed, reset the [transmission oil](#) life monitor if applicable.

Dipstick Level Checking Procedure (If equipped)

1. Park the vehicle on a level surface, apply the parking brake and place the shift lever in PARK (P). Start the engine.
2. Depress the brake pedal and move the shift lever through each gear range, pausing for about 3 seconds in each range. Then move the shift lever back to PARK (P).
3. Allow the engine to idle 500–800 rpm for at least 3 minutes to allow any fluid foaming to dissipate and the fluid level to stabilize. Release the brake pedal.
4. Keep the engine running and observe the [transmission fluid](#) temperature (TFT) using the Driver Information Center or a scan tool.

Caution: The [transmission fluid](#) level must be checked when the [transmission fluid](#) temperature (TFT) is at 85–95°C (185–203°F). If the TFT is not at this temperature, operate the vehicle or allow the fluid to cool as required. Setting the fluid level with a TFT outside this temperature will result in either an under or over-filled transmission. TFT 95°C under-filled, TFT 85°C over-filled. An under-filled transmission will cause premature component wear or damage. An over-filled transmission will cause fluid to discharge out the vent tube, fluid foaming, or pump cavitation.

Note:

- If the TFT reading is not at the required temperature, allow the vehicle to cool, or operate the vehicle until the appropriate TFT is reached. If the fluid temperature is below the specified range, perform the following procedure to raise the fluid temperature to the specification.
- Check the [transmission fluid](#) level when the TFT is at between 85–95°C (185–203°F). The fluid level rises as fluid temperature increases, so it is important to ensure the [transmission fluid](#) temperature is at the specified temperature.

Drive the vehicle in second gear until the fluid temperature is at the specified temperature.

5. The vehicle must be level, with the engine running and the shift lever in the PARK range.
6. Remove the dipstick and wipe it with a clean rag or paper towel.
7. Inspect the fluid color. The fluid should be red or dark brown.
 - If the fluid color is very dark or black and has a burnt odor, inspect the fluid for excessive metal particles or other debris. A small amount of “friction” material is a “normal” condition. If large pieces and/or metal particles are noted in the fluid, flush the oil cooler and cooler lines and overhaul the transmission. If there are no signs of transmission internal damage noted, replace the fluid, repair the oil cooler, and flush the cooler lines.
 - Fluid that is cloudy or milky or appears to be contaminated with water indicates engine coolant or water contamination. Refer to [Engine Coolant/Water in Transmission](#).

8. Install the dipstick. Wait three seconds and then remove it again.

Note: Always check the fluid level at least twice. Consistent readings are important to maintaining proper fluid level. If inconsistent readings are noted, inspect the transmission vent cap to ensure it is clean and unclogged.

Note: It is not necessary to get the fluid level all the way up to the MAX mark. Anywhere within the crosshatch band is acceptable.

9. Check both sides of the dipstick and read the lower level.
10. Install and remove the dipstick again to verify the reading.

Note: Do not add more than one half pint (0.25L) at a time without rechecking the level. Once the oil is on the dipstick bullet, it will not take much more fluid to raise the fluid level into the crosshatch band. Do not overfill. Also, if the fluid level is low, inspect the transmission for leaks. Refer to [Fluid Leak Diagnosis](#).

11. If the fluid level is not within the crosshatch band, and the transmission temperature is at 90°C (194°F), add or drain fluid as necessary to bring the level into the crosshatch band. If the fluid level is low, add only enough fluid to bring the level into the crosshatch band.
12. If the fluid level is in the acceptable range, install the dipstick.
13. If the fluid was changed, reset the [transmission oil](#) life monitor if applicable.

Fluid Condition Inspection

- Inspect the fluid color. The fluid should be red in color. The fluid may also turn brown from normal use, and does not always indicate contamination.

Note: Fluid that is very dark or black and has a burnt odor usually indicates contamination or overheating.

- If the fluid color is very dark or black and has a burnt odor, inspect the fluid for excessive metal particles or other debris which may indicate transmission damage. Refer to [Road Test](#) to verify transmission operation. Change the [transmission fluid](#) if no other conditions are found.
- Fluid that is cloudy or milky or appears to be contaminated with water indicates engine coolant or water contamination. Refer to [Engine Coolant/Water in Transmission](#).

© 2014 General Motors. All rights reserved.

Portions of materials contained herein are sourced from General Motors Inc., Co.

Copyright 2007 - 2014 Service Repair Solutions, Inc.