

TRANSMISSION FLUID DRAIN AND ...

TRANSMISSION FLUID DRAIN AND FILL (AUTOMATIC TRANSMISSION - 6T30/6T35/6T40/6T45/6T50)

Document ID#
3701945**TRANSMISSION FLUID DRAIN AND FILL (AUTOMATIC TRANSMISSION - 6T30/6T35/6T40/6T45/6T50)****Draining Procedure****Warning:**

When the transmission is at operating temperatures, take necessary precautions when removing the check/fill plug, to avoid being burned by draining fluid.

Transmission Fluid Draining Warning:

The transmission fluid is hot. Caution must be taken to prevent personal injury when the transmission fluid drains from the transmission.

Note: Previous to the removing of any plug, clean the surrounding area of this plug.

1. Raise and support the vehicle. [Lifting and Jacking the Vehicle](#) .
2. [Front Compartment Air Deflector Replacement](#) » Remove

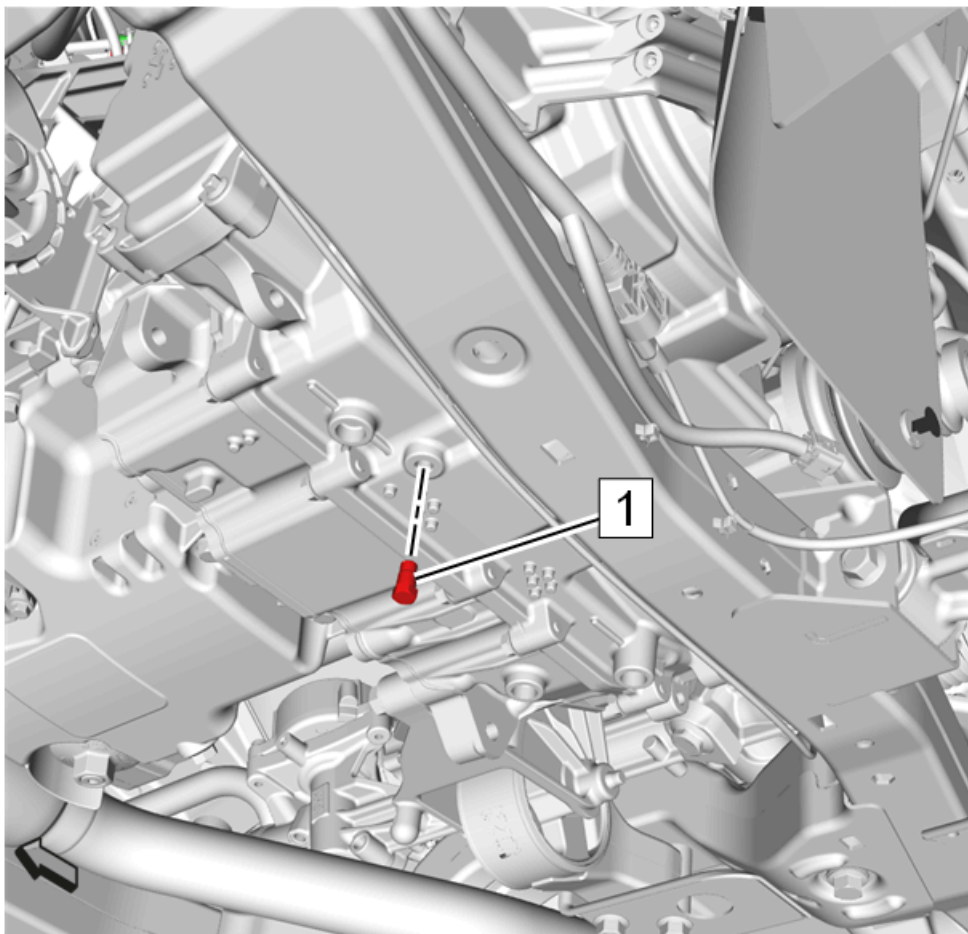

3. Fluid Drain Plug (1) » Remove
 4. Drain the [transmission fluid](#) into a suitable container.
 5. Let the [transmission fluid](#) run out for 10 minutes and check the [transmission fluid](#) amount. If necessary, fill up the drained amount to the proper level with the correct fluid. Refer to [Transmission General Specifications](#) and [Approximate Fluid Capacities](#) .
 6. Check the collected [transmission oil](#) for burnt oil exhalation, metal chips and other foreign bodies. If this the fact, search for the reason caused by the transmission.
- Caution:** Refer to [Fastener Caution](#) .
7. Fluid Drain Plug (1) » Install and tighten **12 N•m (106 lb in)**

Filling Procedure

1. Lower the vehicle.

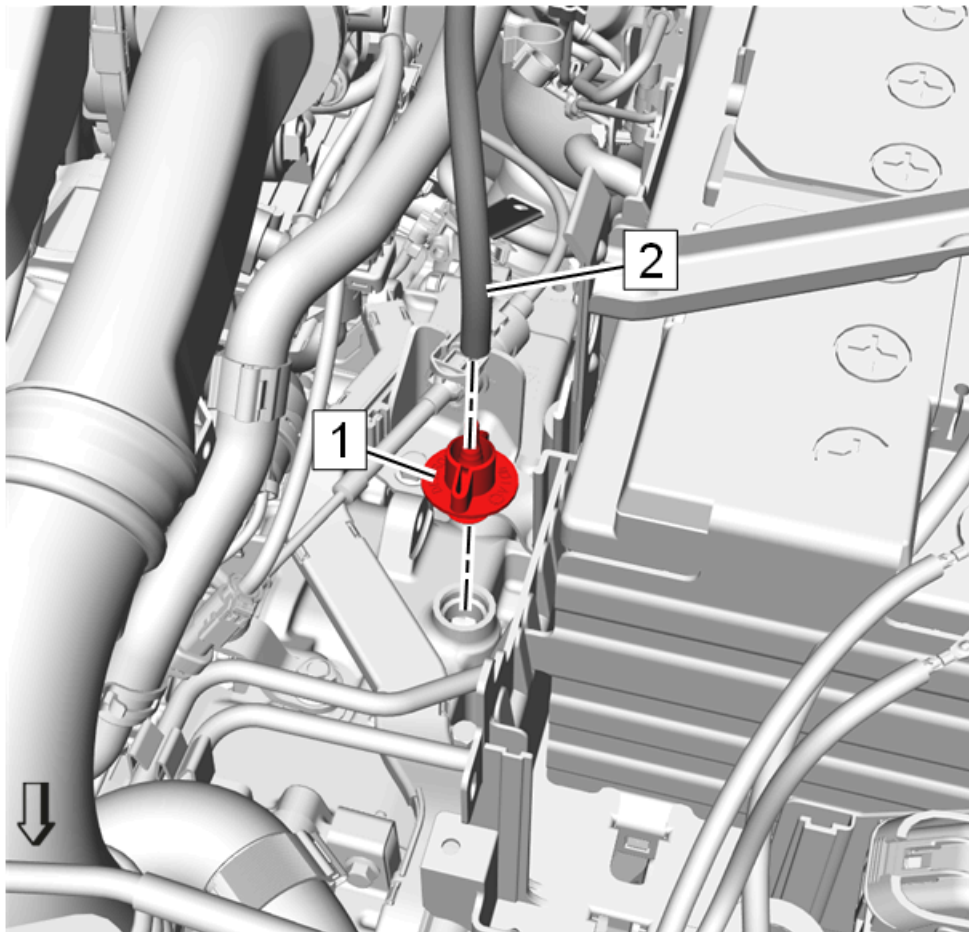

2. Remove the transmission vent hose (2) and the fluid filler cap (1).
3. Fill the transmission with the proper amount of the correct fluid. Refer to [Transmission General Specifications](#) and [Approximate Fluid Capacities](#) .
4. Install the fluid filler cap (1) and the transmission vent hose (2).

Fluid Level Check

1. Start the engine.
2. Depress the brake pedal and move the shift lever through each gear range, pausing for about 3 seconds in each range. Then move the shift lever back to PARK (P).
3. Allow the engine to idle between 500 to 800 RPM for at least 3 minutes, to allow any fluid frothing to dissipate and the fluid level to stabilize. Release the brake pedal.

Fill Transmission at the Proper Temperature Caution: The **transmission fluid** level must be checked when the **transmission fluid** temperature (TFT) is at 85-95°C (185-203°F). If the TFT is not at this temperature, operate the vehicle or allow the fluid to cool as required. Setting the fluid level with a TFT outside this temperature will result in either an under or over-filled transmission. TFT over 95°C under-filled, TFT under 85°C over-filled. An under-filled transmission will cause premature component wear or damage. An over-filled transmission will cause fluid to discharge out the vent tube, fluid foaming, or pump cavitation.

4. Keep the engine running and observe the **transmission fluid** temperature (TFT), using the Driver Information Center or a scan tool.

Transmission Fluid Fill Caution: When performing a **transmission fluid** fill, verify that the vehicle is raised level. A vehicle that is not horizontally aligned will result in too high or too low **transmission fluid** level. An under or over filled transmission will cause malfunction or damage to the transmission.

Note: While checking the fluid level, the engine must be running and the shift lever has to be in the PARK range.

5. Raise the vehicle on a hoist.

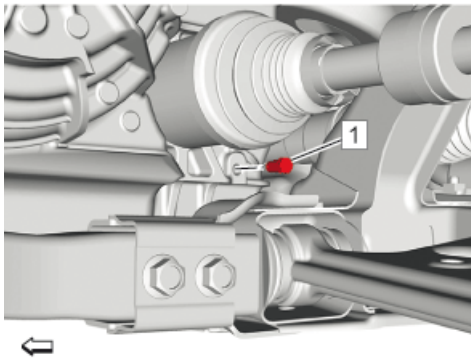

Checking Hot Transmission Fluid Through Drain Plug Hole Warning:

The engine must be running when the transmission fluid fill plug is removed, or excessive fluid loss will occur. Transmission fluid may be hot. Since the actual fluid level is unknown, stand clear when removing the fill plug. Have a container ready to capture any lost fluid. Do not turn the engine off with the fill plug removed, as you can be injured by hot transmission fluid being expelled out of the oil fill opening.

6. While the vehicle is idling, remove the fluid level plug (1). Allow any fluid to drain into a drip pan.
 - If the fluid is flowing as a steady stream, wait until the fluid drips out one time per second. Continue with step 12.
 - If no fluid comes out, add fluid until it drips out of the fluid level plug hole one time per second. Continue with step 7.
7. Lower the vehicle.

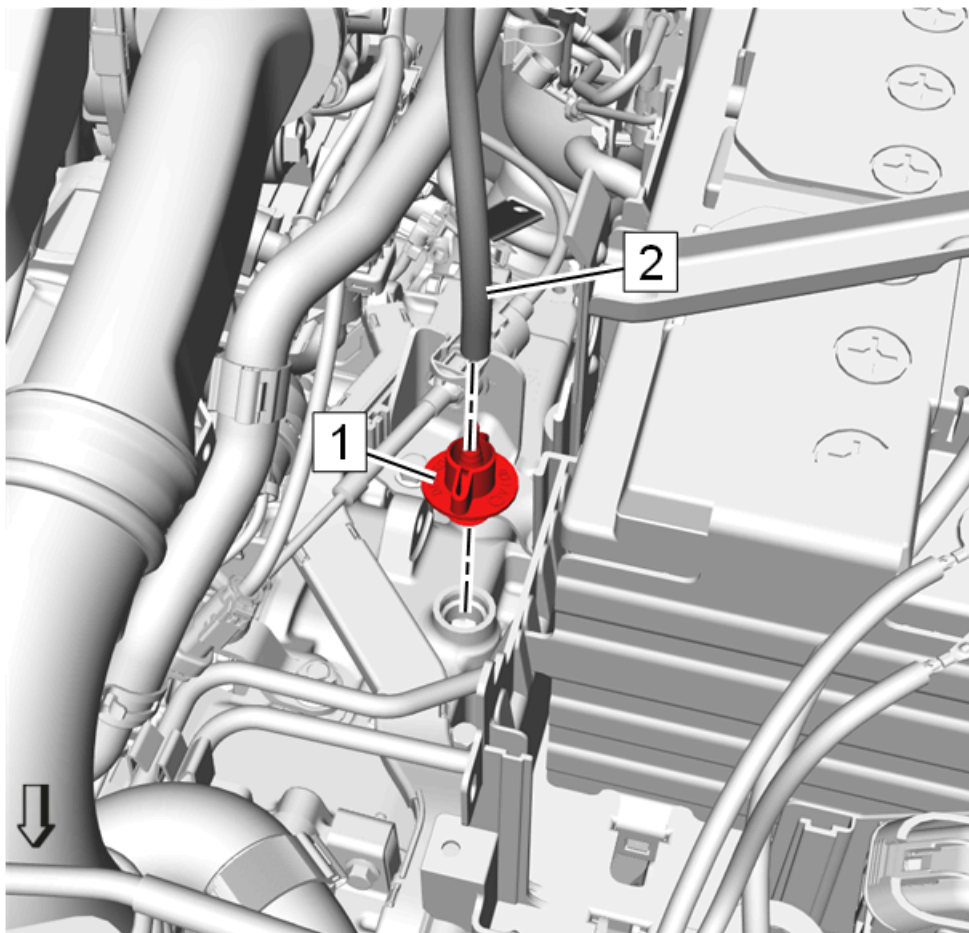

8. Remove the transmission vent hose (2) and the transmission fluid filler cap (1).

9. While the vehicle is idling, add fluid through the fluid filler cap hole, until fluid is flowing as a stream out of the fluid level plug hole. Wait until the fluid is only dripping out of the fluid level plug hole one time per second.
10. Install the [transmission fluid](#) filler cap (1) and the transmission vent hose (2).
11. Raise the vehicle.

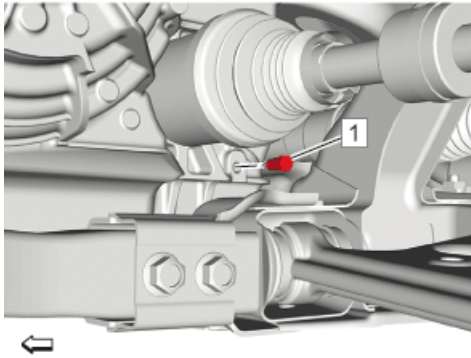

Caution: Refer to [Fastener Caution](#) .

12. Install the fluid level plug (1) and tighten to **12 N•m (106 lb in)** .
13. Lower the vehicle.
14. Stop the engine.
15. Raise the vehicle.
16. [Front Compartment Air Deflector Replacement](#) » Install
17. Lower the vehicle.

Portions of materials contained herein are sourced from General Motors Inc., Co.

Copyright 2007 - 2018 Service Repair Solutions, Inc.