

8

7

6

5

4

3

DWG NO. 6212019-SK

SH 1 REV

1

D

D

C

C

B

B

A

A

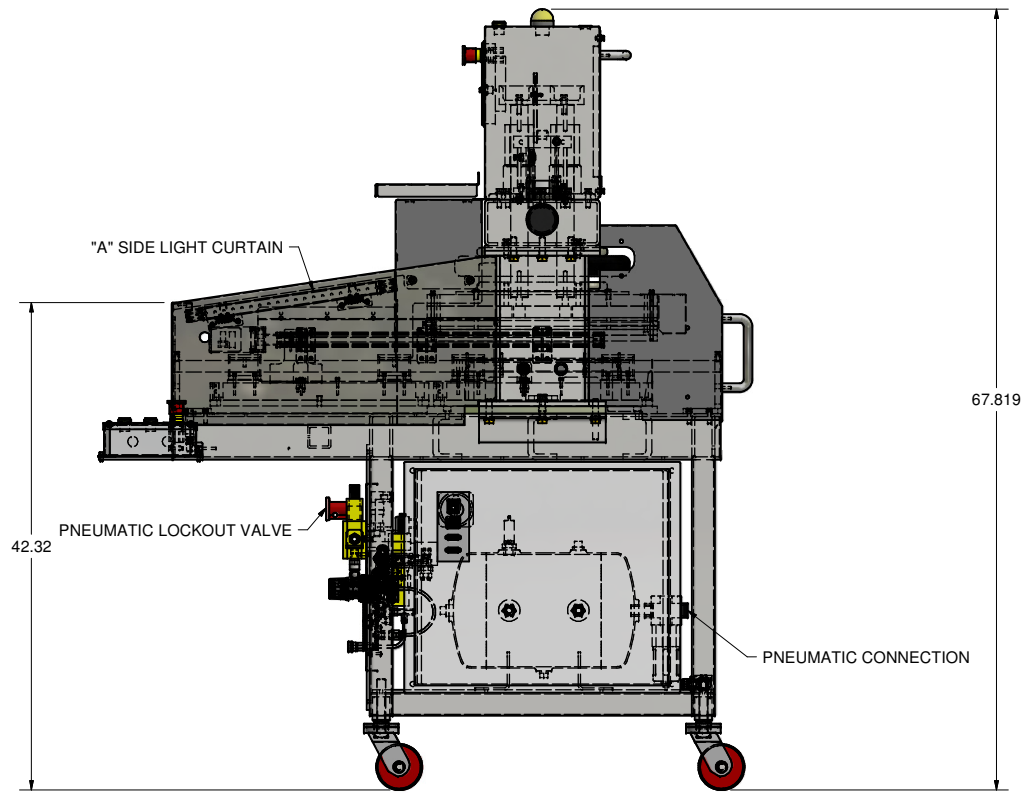
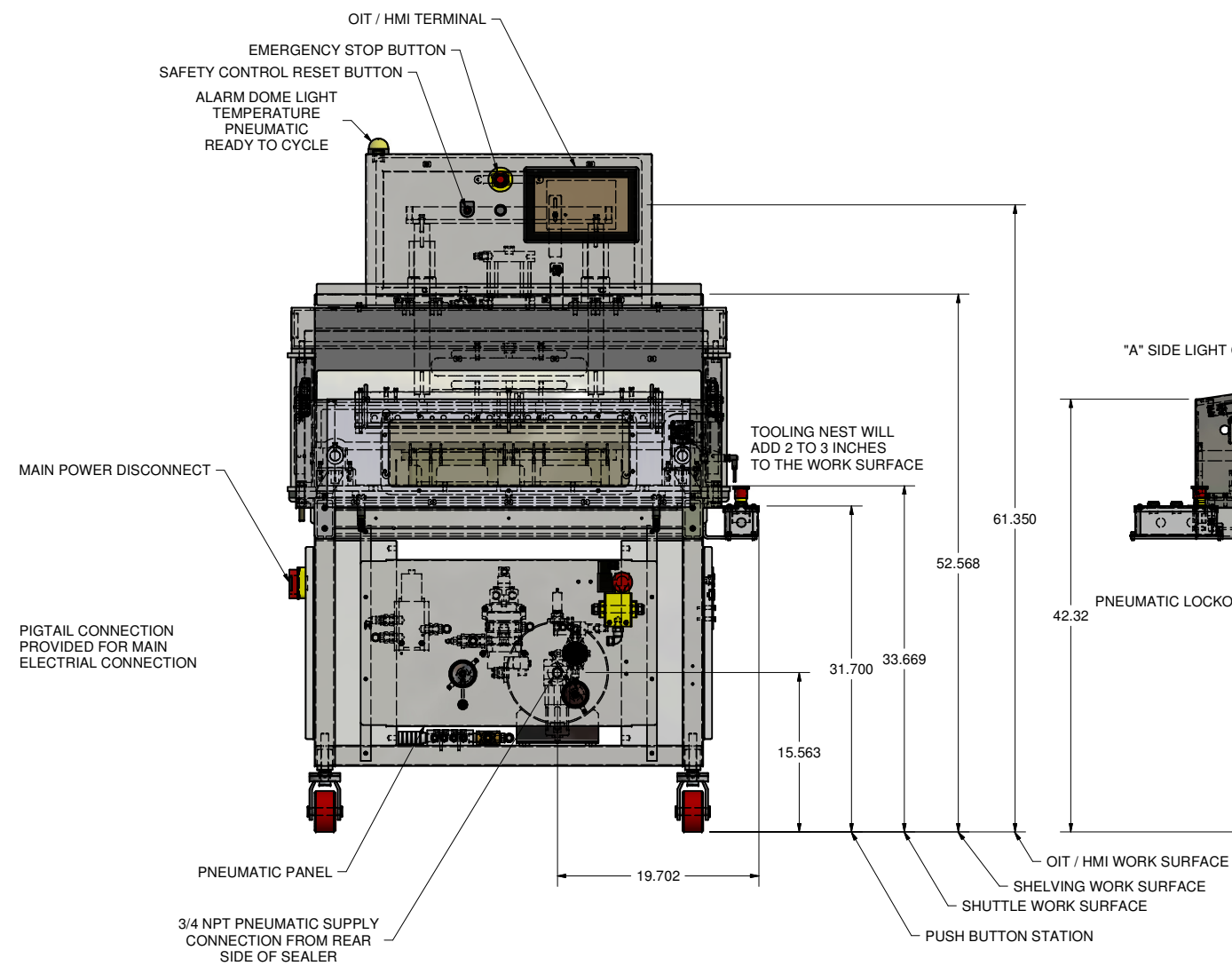
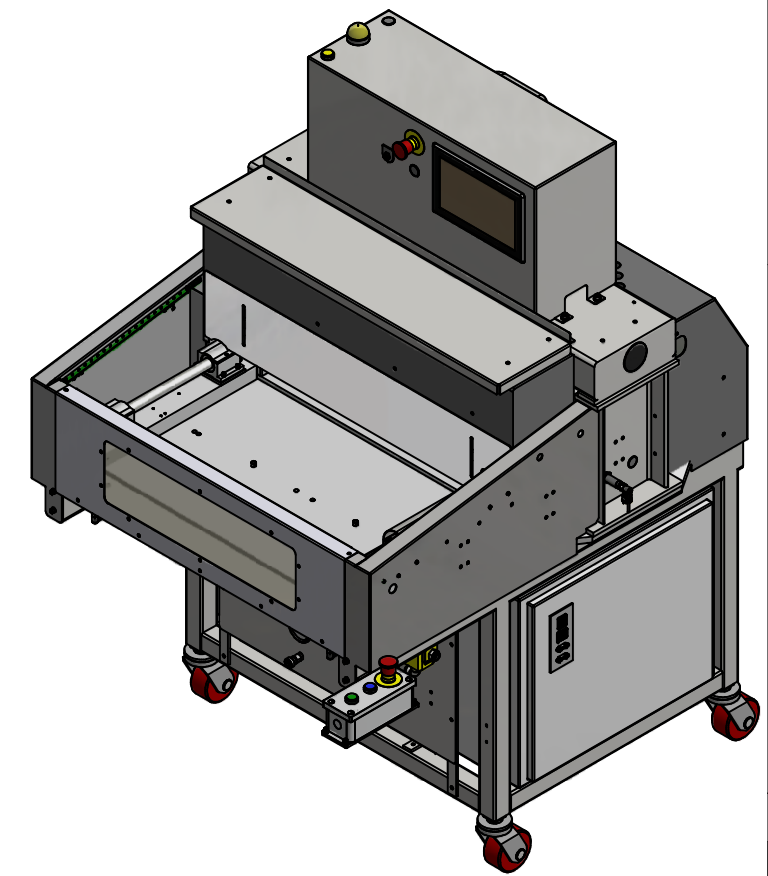
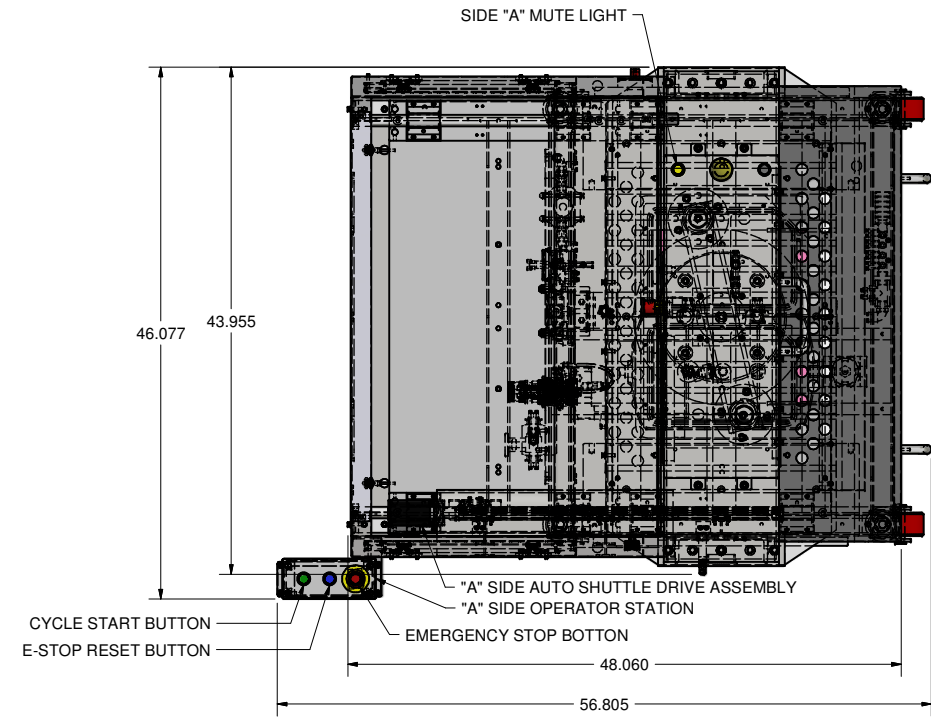

STATEMENT OF OWNERSHIP: THIS MATERIAL IS THE EXCLUSIVE PROPERTY OF ATLAS VAC MACHINE LLC AND MUST BE RETURNED TO ATLAS VAC MACHINE LLC IMMEDIATELY UPON REQUEST. THIS MATERIAL AND THE INFORMATION ILLUSTRATED OR CONTAINED HEREIN MAY NOT BE REPRODUCED, COPIED, USED OR TRANSMITTED IN WHOLE OR PART IN ANY WAY WITHOUT THE PRIOR WRITTEN CONSENT OF ATLAS VAC MACHINE LLC. UNLICENSED DUPLICATION OF ANY ATLAS VAC MACHINE LLC COMPONENT OR ASSEMBLY ILLUSTRATED IN WHOLE OR PART IS PROHIBITED AND SUBJECT TO PROSECUTION.

UNLESS OTHERWISE SPECIFIED DIMENSIONS ARE IN INCHES. TOLERANCES ARE: .X ±.1 ANGLES ±1° .XX ±.015 SURF FINISH 125 .XXX ±.005 SURF FINISH V DO NOT SCALE DRAWING		CONTRACT NO.		Atlas Vac Machine	
THIRD ANGLE PROJECTION		APPROVALS	DATE	DESCRIPTION	
MATERIAL		DESIGN	Mike	1830S TRAY SEALER ASSEMBLY	
TREATMENT		MFG	4/25/2019	SIZE	CAGE CODE
FINISH		CAD FILE NAME	1830S Pan LC Assembly.idw	D	99296
		SCALE		DWG. NO.	6212019-SK
				REV.	1 OF 1

DWG NO. 6212019-SK

SH 1 REV

N:\Atlas Vac Models, R&D\18-30 Dual Side Updated\1830S Pan LC Assembly.idw