



www.functionsmith.com

 **FUNCTIONSMITH, INC.**  
MANILA • GUANGZHOU  
- COLLECTION 2022~2023 - **34<sup>th</sup>**



 **FUNCTIONSMITH, INC.**  
MANILA • GUANGZHOU

779 Acacia Street, Octagon Industrial Estate Subdivision,  
Barangay Dela Paz, Pasig City, 1600  
Metro Manila, Philippines

+632 7753-2292 | +632 7753-2359 | +632 7148-5208  
+632 8645-4994 | +632 8645-2664 | +632 8645-4284

sales@functionsmith.com / marketing@functionsmith.com

*The company reserves the right to make change on the product appearance and accessories, will not have any further notice.  
The dimension and color of all our products are according to the actual material of our goods.*



# Index

Office chair series  
p.01

Folding table series  
p.51

Lounge area series  
p.81

Others  
p.103



## Index

Office chair series	Folding table series	Lounge area series	Others
B246 ..... 48	C80 ..... 69, 71	B313 ..... 99	C150 ..... 103
B273 ..... 49	C81 ..... 72, 74	B323 ..... 95	D03 ..... 105
B298 ..... 35	C82 ..... 80	B328 ..... 91	
B300-A ..... 24	C85 ..... 79	B363 ..... 88, 90	
B300 ..... 21	C99 ..... 78	B373 ..... 87	
B301 ..... 41	C100 ..... 61	B380 ..... 81	
B302 ..... 42	C101 ..... 70, 75		
B311 ..... 29	C139 ..... 68		
B318 ..... 01	C146 ..... 57		
B350 ..... 20	C147 ..... 58		
B356-2 ..... 45	C151 ..... 51		
B361 ..... 05	C156 ..... 56		
B362 ..... 17	H81 ..... 70, 72		
B366 ..... 15	H100 ..... 62		
B377 ..... 11			
B378 ..... 09			
B381 ..... 13			





**B318**

Body  
Seat and back in RB mesh.



B318



Type



Mod. B318-1



Mod. B318-2

Aluminium back





Mod. B361-1 chair;  
Mod. C146 table.

## B361 series



Mod. B361-1



Mod. B361-1



Mod. B361-3

OFFICE CHAIRS

06

### Body

Seat covered with **O** fabric.

### Frame



white

black

### 'O' fabric

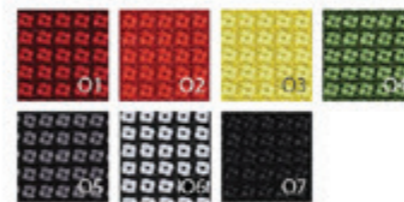

B361

B361



Mod. B361-1 chair  
 Mod. C81-18 table



Mod. B378-1 chair;  
Mod. B318-1 chair;  
Mod. C81-18-A table.



**Body**  
Seat and back in **B** fabric.

**Base**  
chromed black

**'B' fabric**  
B1 B2 B3  
B4 B5 B6  
B7





*Mod. B377-2 chair;  
Mod. C135-75H table.*



*Mod. B377-1, Mod. B377-4,  
Mod. B377-3B, Mod. B378-3  
chair.*



**Body**  
Seat and back in **B** fabric.

**Base**

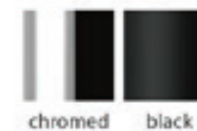

**'B' fabric**

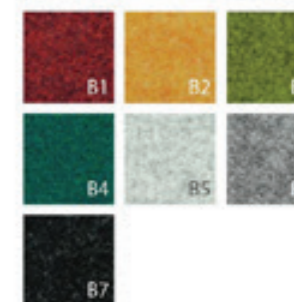

B381



Mod. C150 table  
Mod. C151 table



OFFICE CHAIRS

13



OFFICE CHAIRS

14



 **FUNCTIONSMITH, INC.**  
MANILA • GUANGZHOU

**Body**  
Seat and back in E fabric.

**Iron base**



black

**'E' fabric**

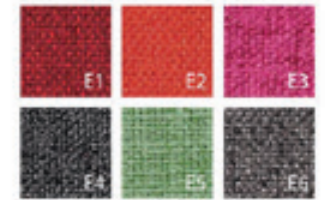

E1

E2

E3

E4

E5

E6

Mod. B318-1 chair,  
Mod. B366 chair,  
Mod. C81-18-A table.



Patent No:  
202030443433.0

**Body**  
Seat and back in **O** fabric.

**Aluminium base**

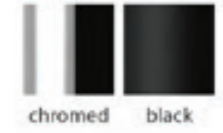

**'O' fabric**

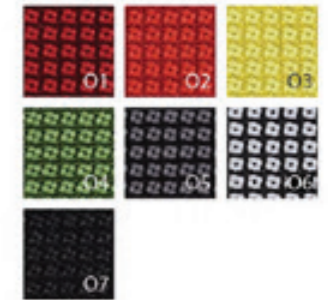

B362

OFFICE CHAIRS

17



Mod. B318-1 chair;  
 Mod. B362 chair;  
 Mod. C100-18-B table.

B362

OFFICE CHAIRS

18



**Body**  
 Seat and back in **O** fabric.

**Aluminium base**

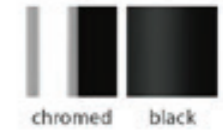

**'O' fabric**

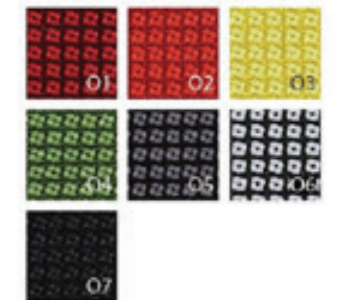



Mod. B318-1 chair;  
 Mod. B350 chair;  
 Mod. C81-18-A table.

**B350**



**Body**  
 Seat and back in A fabric, X bonded leather.

**Aluminium base**

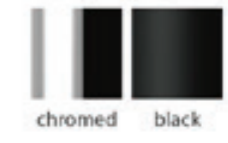

**'A' fabric**





Mod. B300 chair  
Mod. C100-18-W table

**B300 & B300-A**

Type



Mod. B300



Mod. B300-A



Mod. B300-A



Mod. B300-A



Body  
Seat and back in R mesh.

Aluminium base



Mod. B300



Mod. B300-A

B300



Mod. B300 chair  
Mod. C100-18-W table

B300-A



Mod. B300-A chair  
Mod. C100-18-W table



Mod. B300-A chair  
Mod. C100-18-W table



*Mod. B300-A chair*  
*Mod. C100-18-B table*





*Mod. B311-1 chair*  
*Mod. C100-18-B table*



Type



*Mod. B311-1*  
*Chrome aluminium base*



*Mod. B311-2*  
*Powder coated aluminium base*



*Mod. B311-2*  
*Powder coated aluminium base*



*Mod. B311-4*  
*Nylon base*

Body

Seat and back in R mesh.

Aluminium base



Nylon base



'R' mesh



*Mod. B311-2 chair*  
*Mod. C100-18-W table*





Mod. B311-2 chair  
Mod. C100-18-W table



Mod. B311-4 chair  
Mod. C100-18-W table



Type



Mod.B298-1



Mod. B298-2

Aluminium base



chromed

'R' fabric



R1

R2

R3

Patent No:  
201230268784.8

Body

- 1. Mod. B298; Seat and back in R mesh;
- 2. Mod. B298-A; Seat in X bonded leather, back in R mesh.



Mod. B298



Mod. B298-A



OFFICE CHAIRS

37

Mod. B298-2 chair  
 Mod. C81-15 table



OFFICE CHAIRS

38

B298-1

B298-1

OFFICE CHAIRS

39



OFFICE CHAIRS

40

B301



OFFICE CHAIRS

41

Mod. B301 chair  
Mod. C100-18-W table



Mod. B302 chair

B301 & B302

Type



Mod. B302



Mod. B302



Mod. B301

OFFICE CHAIRS

42

Aluminium base



chromed

Nylon base



black

'R' fabric



R1

R2

R3

Body

- 1. Mod. B302; Seat and back in R mesh;
- 2. Mod. B302-A; Seat in U Pvc, back in R mesh;
- 3. Mod. B302-U; Seat and back in U Pvc.



Mod. B302



Mod. B302-A



Mod. B302-U



B301 & B302

OFFICE CHAIRS

43



OFFICE CHAIRS

44

*Mod. B302-U chair*  
*Mod. C81-18-A table*

B356-2

OFFICE CHAIRS

45



*Mod. B356-2 chair covered with W Pvc  
Mod. C100-18-B table.*

**FUNCTIONSMITH, INC.**  
MANILA • GUANGZHOU

B356-2



OFFICE CHAIRS

46

**Body**  
Seat and back in **W Pvc** or **C fabric**.

(Patent No:  
201930012421X

Mod. B246-1 chair covered in X bonded leather;  
Mod. C80-A table.



OFFICE CHAIRS

47

Type



Mod.B246-1



Mod.B246-2



Mod.B246-3



OFFICE CHAIRS

48

**Body**  
Mod. B246-1: Seat and back in X bonded leather;  
Mod. B246-2, Mod. B246-3: Seat and back in U Pvc.

**Aluminium base**  
chromed

**'U' Pvc**  
U2 U3

Mod. B246-1 chair covered in X bonded leather;  
Mod. B318-1 chair;  
Mod. C100-18-B table.

## B273

Body

Seat and back in J fabric.

Mod. B273 chair;  
Mod. C98 table.







### C151 series

Size

Mod. C151-60  
Size: 60 x 60 x 75H cm



Mod. C151-90  
Size: 90 x 60 x 75H cm



Mod. C151-60A  
Size: 60 x 60 x 75H cm



Mod. C151-90A  
Size: 90 x 60 x 75H cm



Table top  
L

 **FUNCTIONSMITH, INC.**  
MANILA • GUANGZHOU



Patent No:  
202120594769.6  
202130159591.8



Size

Mod. C156  
Size: 220 x 120 x 75H cm



Mod. B361-1 chair



Patent No:  
202021912451.X  
202021913352.3

Table top



FOLDING TABLES





FOLDING TABLES

57

Mod. B361 chair  
Mod. C146 table



**C146 & C147**

Size

Mod. C146-15  
Size: 180 x 80 x 75H cm



Mod. C146-19  
Size: 220 x 80 x 75H cm



Mod. C147  
Size: Ø160 x 75H cm



Table top  
L

FOLDING TABLES

58





# C147

Size:  $\varnothing 160 \times 75H$  cm

FOLDING TABLES

59



FOLDING TABLES

60

C100



61

Mod. B298-1 chair  
Mod. C100 table

FUNCTIONSMITH, INC.  
MANILA • GUANGZHOU

Type

Mod. C100-15



Mod. C100-18



Mod. C100-15R

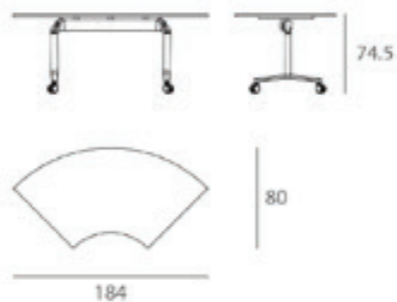

Mod. H100-15 (150 x 80)  
Mod. H100-18 (180 x 80)

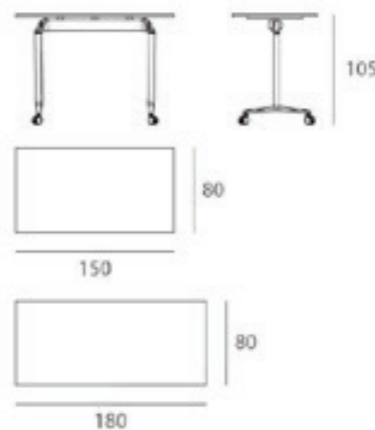

Colours of the legs



Mod. C100-B



Mod. C100-W

Table top



C100 & H100



62



专利号[Patent No]:  
201920455662.6

**C100**



Mod. C100-15-W  
Size: 150 x 80 x 74.5H cm



Mod. C100-18-W  
Size: 180 x 80 x 74.5H cm



[Patent No:  
201920455662.6



**C100**



Mod. B356-2 chair  
Mod. C100-18-B table



C100



Mod. C100-15R-W  
Size: 184 x 80 x 74.5H cm



C100



Mod. C100-15R-B  
Size: 184 x 80 x 74.5H cm

Mod. B298-2 chair





Type

Mod. C139-12

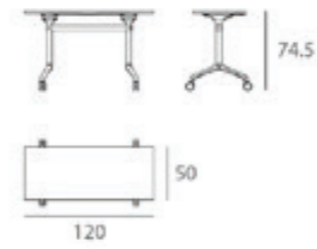

Mod. C139-15

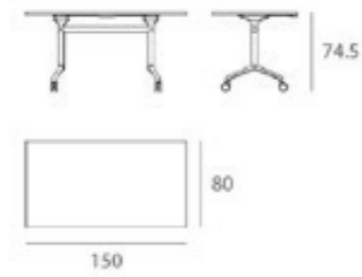

Mod. C139-18



Patent No:  
201721393131.6

Table top





FOLDING TABLES

69

*Mod. B301 chair*  
*Mod. C80 table*

**Type**

*Mod. C80*

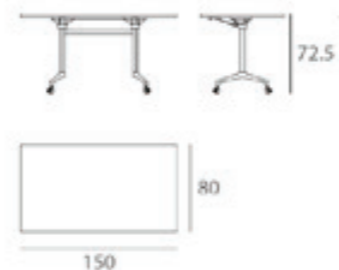

*Mod. C80-A*



*Mod. C81-15 (150 x 80)*  
*Mod. C81-18 (180 x 80)*

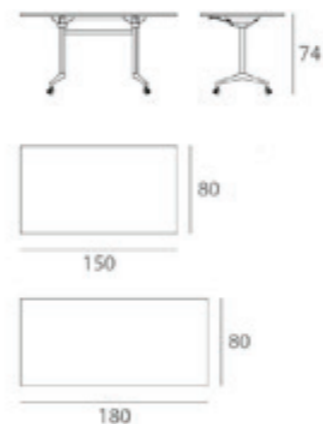

*Mod. C81-15-A (150 x 80)*  
*Mod. C81-18-A (180 x 80)*

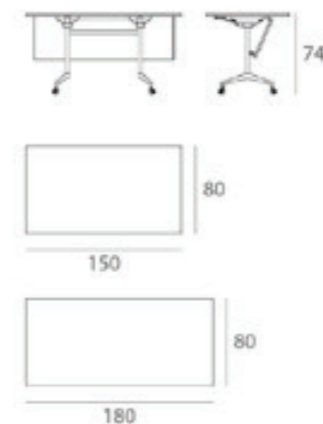

*Mod. H81-15 (150 x 80)*  
*Mod. H81-18 (180 x 80)*

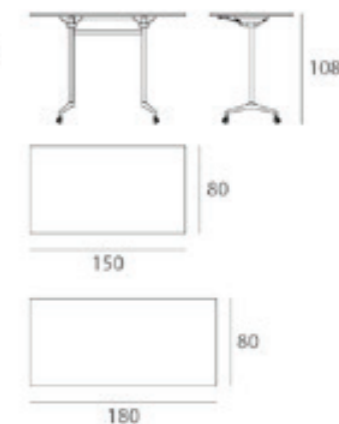

*Mod. C101-15*



*Mod. C101-18*

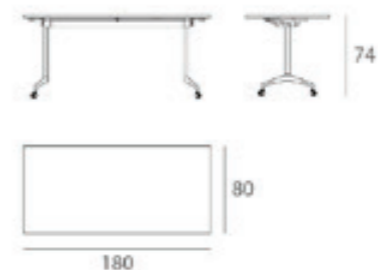

**Table top**



[Patent No:  
201920456830.3



*Mod. C80*



*Mod. C81, Mod. H81*

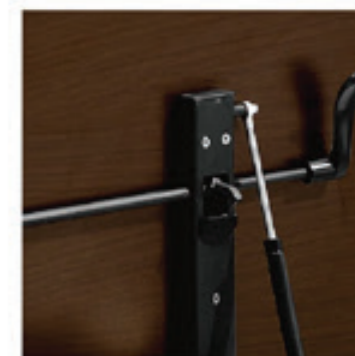

*Mod. C101*

FOLDING TABLES

70

## C80 & C80-A



Mod. C80  
Size: 150 x 80 x 72.5H cm



Mod. C80-A  
Size: 180 x 80 x 72.5H cm



Mod. B318-1 chair  
Mod. C80-A table



## H81



Mod. H81  
Size: 150 x 80 x 105H cm



Mod. B385 barstool.

# C81



Mod. C81-15  
Size: 150 x 80 x 74H cm



Mod. C81-18  
Size: 180 x 80 x 74H cm

[Patent No:  
201920456830.3



FUNCTIONSMITH, INC.  
MANILA • GUANGZHOU



# C81-A



Mod. C81-15-A  
Size: 150 x 80 x 74H cm



Mod. C81-18-A  
Size: 180 x 80 x 74H cm





# C101



Mod. C101-15  
Size: 150 x 80 x 74H cm



Mod. C101-18  
Size: 180 x 80 x 74H cm



Mod. B302 chair



Mod. B298-3 chair  
Mod. C99 table



Mod. C99-15-A table

Type

Mod. C99-15

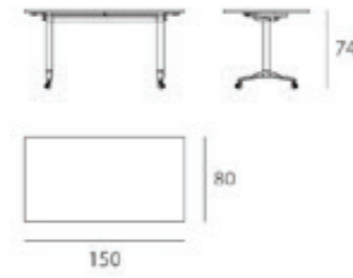

Mod. C99-18

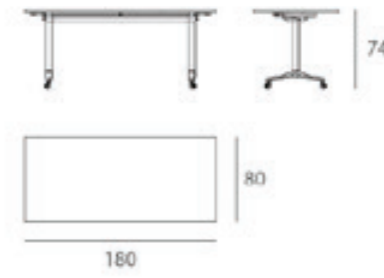

Mod. C99-15-A

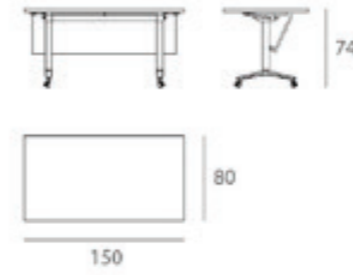

[Patent No:  
201920456829.0

Table top



C85



FOLDING TABLES

79

C82



FOLDING TABLES

80



Table top

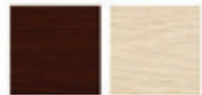

D L

Size: 150 x 60 x 73.5H cm



Table top

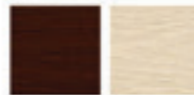

D L

Size: 160 x 90 x 72.5H cm

B380



Mod. C125-50H table

81

Type



Mod. B380



Mod. B380-A

Body

Seat and back covered with B fabric.



Mod. C118 table

Mod. C108 table;  
Mod. B380-A chair.



LOUNGE AREA

82

B380

Mod. C108 table;  
Mod. C125-50H table.

LOUNGE AREA

83



LOUNGE AREA

84

B363

LOUNGE AREA

85



LOUNGE AREA

86

Mod. C155 table;  
Mod. C125-50H table.

**B373**



*Mod. B373-1*  
*Sofa covered with O fabric.*



*Mod. B373-2*  
*Sofa covered with O fabric.*

*Mod. C116 table*



**B363**

LOUNGE AREA

87



*Mod. C109 table;*  
*Mod. C116 table;*  
*Mod. B305 stool*  
*covered with C fabric.*



*Mod. B363-1*  
*Sofa covered with O fabric.*

 **FUNCTIONSMITH, INC.**  
MANILA • GUANGZHOU



*Mod. B363-2*  
*Sofa covered with O fabric.*

Patent No:  
202030443033.X  
202030443035.9

B363

 **FUNCTIONSMITH, INC.**  
MANILA • GUANGZHOU

LOUNGE AREA

89



LOUNGE AREA

90

Mod. C109 table;  
Mod. C116 table.





Mod. C110-5, C110-6 coffee table;  
Mod. B305 stool covered with J fabric.

LOUNGE AREA

91

LOUNGE AREA

92



Mod. B328-1  
Sofa covered with M fabric.



Mod. B328-1-2  
Sofa covered with M fabric.

B328

LOUNGE AREA

93



B328

LOUNGE AREA

94



Mod. C107-55-Y coffee table;  
Mod. C107-110-Y coffee table.



Mod. C107-55-Y coffee table;  
Mod. C107-110-Y coffee table.



Mod. B323-1  
Sofa covered with M & N fabric.



Mod. B323-2  
Sofa covered with M & N fabric.



B323-1, B323-2 sofa covered with C fabric.



B323-D-I sofa covered with C fabric.

Table top



Mod. C107-55-W  
Size: 55 x 55 x 50H cm



Mod. C107-110-Y  
Size: 110 x 60 x 42.5H cm

B323

LOUNGE AREA

99



Mod. B323-1, B323-2 sofa covered with M+C fabric.  
 Mod. B305 stool covered with C fabric.  
 Mod. C141 table.  
 Mod. C142 table.



B313

LOUNGE AREA

100

B313-1, B313-2 sofa covered with J fabric.

Table top



Mod. C105-55-W  
 Size: 55 x 55 x 50H cm



Mod. C105-110-W  
 Size: 110 x 60 x 42.5H cm

# B313

Mod. C130-6 coffee table;  
Mod. C131 coffee table;  
Mod. B305 stool covered with C fabric.

LOUNGE AREA

101



Mod. B313-1  
Sofa covered with C fabric.



Mod. B313-2  
Sofa covered with C fabric.



LOUNGE AREA

102



Size: 56 x 42 x 92 ~ 128.5H cm

Colours

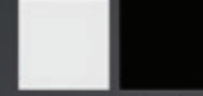

white black



Patent No:  
202130178949.1  
202120654844.3



OTHERS

105



OTHERS

106



Colours



white

black

'O' fabric

