

CTECK

INSTALLATION MANUAL





WARNING

Information contained in this manual is protected by copyright and is the exclusive property of Optimal Air Conditioning Solutions Pty Ltd (Optimal). The information contained herein must not be copied in any form or transferred to third parties without the consent of Optimal.

The information contained in this manual is to be used as a general guide only. Optimal reserves the right to amend the design and specifications of the products included in this publication.

CTECK

CTECK

OVERVIEW

The CTECK solution is used for reducing the energy consumed by the compressor in a basic Inverter air conditioning system via the Demand Response Enable Device (DRED) terminals.

- a. NOTE Some systems may need a DRED interface card from the manufacturer to be purchased by the installing contractor separately from the manufacturer and installed by the installing contractor.

HARDWARE

1. 12VDC power input.
2. 3 x Voltage free dry contact Switched outputs terminals to DRED interface.
3. 2 x Analogue Input terminals for current transducer.
4. 3 x Analogue Input terminals for outside air ambient temperature sensor.

CONNECTIONS

Field Connections for the systems is via screw terminal blocks located at the top and bottom of the unit.

Appropriate connection diagrams are attached for type of installation.

EQUIPMENT REQUIRED

The following is a list of equipment is the minimum required to successfully install a CTECK system.

Tools and Equipment

1. Multi meter to measure:
 - a. Voltage up to 440VAC
 - b. DC Voltage
 - c. Current up to 500 amps
 - d. Ohms
2. Cordless drill.
3. Appropriate ladders and safety equipment.

Although the CTECK devices are very small it may occasionally not fit inside the condenser unit and may have to be installed inside a separate IP65 enclosure.



CTECK

INSTALLATION PROCESS

1. Select an appropriate location to mount the CTECK unit within the control section of the condenser unit.
2. The CTECK unit is mounted onto DIN rail with the 12VDC power supply and a 2 amp circuit breaker.
3. The 240VAC/12VDC regulator requires a permanent 240VAC supply from within the condenser unit.
4. There is a current transducer (CT) rated up to 20 amps supplied with each unit. If the unit is rated between 20 and 30 amps, a 30 amp CT must be ordered with the CTECK unit.
5. The temperature sensor is mounted on the outside next to the condenser coil. It must be secured with cable ties. Where possible mount next the existing outside ambient temperature sensor
6. If the condenser is single phase the active power cable is disconnected from the terminal strip and passed through the CT and re-connected to the terminal strip.
7. If the condenser unit is 3 phase, The phase the evaporator fan is connected to is disconnected from the terminal strip, passed through the CT and reconnected to the terminal strip.
8. Inside each CTECK is a selector with numbers 0-9. The maximum current draw of the AC unit is required to set this switch to. Often the current rating on the unit shown on the information plate can be up to 25% higher than the actual current consumed by the unit. The AC unit must be tested at full load by selecting the minimum cooling set point and run the AC unit for a minimum of 5 minutes and measure the maximum current of the AC unit. When the maximum current is read from the test, set the switch relative to the table below.

Measure the maximum current of the AC unit by setting a low temperature set point and running it for at least 5 minutes to measure the maximum current reached.

DIAL SETTING	CURRENT RANGE	3 PHASE DUCTED OR VRF
0	3	Measure the current of the Phase with the evaporator connected
1	5	
2	7	
3	10	
4	13	
5	17	
6	21	
7	25	
8	29	
9	Test	

After testing the air conditioning system for maximum current turn the Config Setting Dial to the closest recorded current range.

Note: Do NOT use Dial Setting 9



CTECK



Current Config Setting switch
see table and instructions

All work must be carried out by qualified electrical staff in accordance with the local electrical Authority requirements and all Occupation Health and Safety requirements of the client.

The contractor is responsible to provide all works descriptions required by the clients and the associated paperwork. The contractor is also required to arrange appropriate access on site to complete the installation of the CTeck devices.

CTECK

CIRCUIT DIAGRAM

TYPICAL CTECK, DRED INTERFACE WIRING DIAGRAM

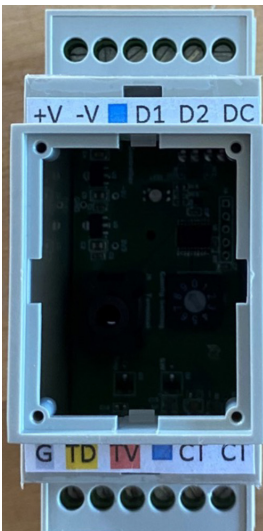
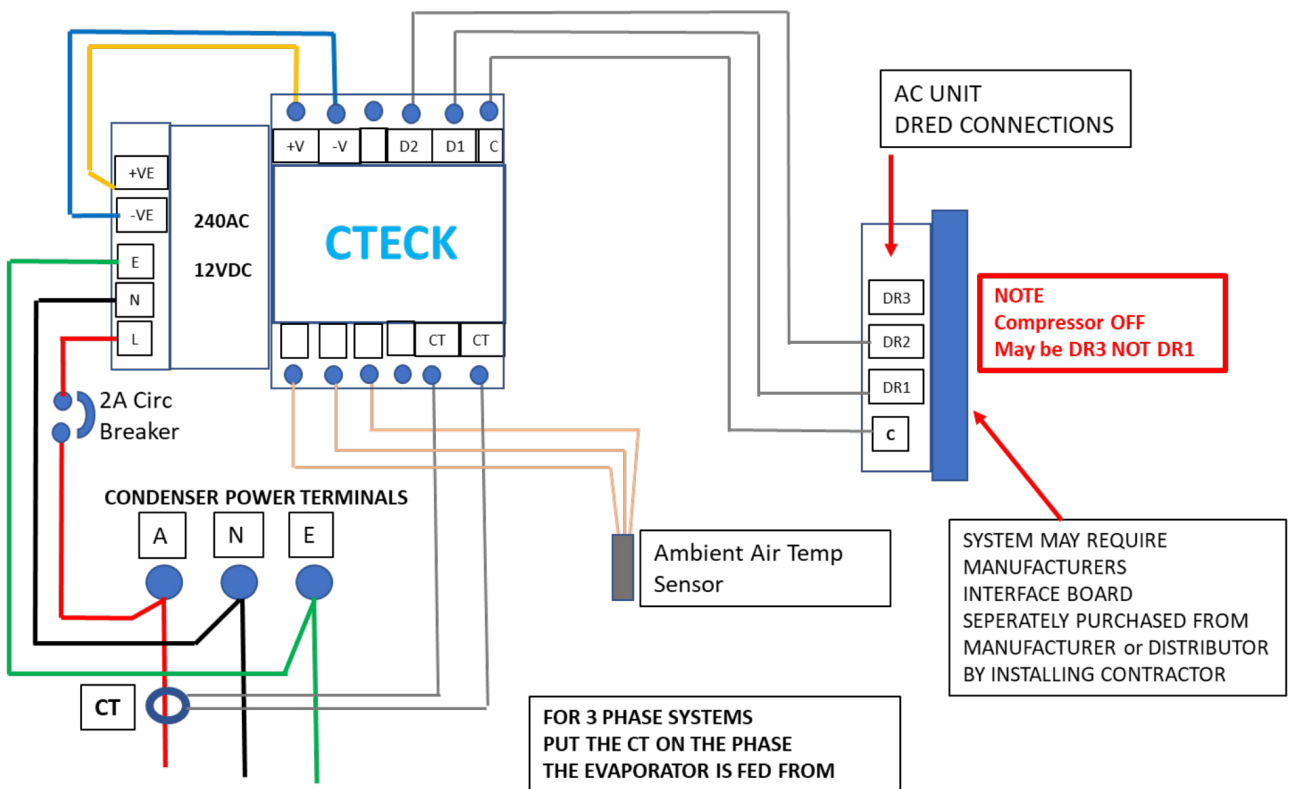

- +V = +12 Volts DC
- V = - 12 Volts DC
- D2 = DRM2 = No more than 50%
- D1 = DRM1 = Compressor Off
- C = DRED Common Point Sometimes +5V)
- TV = Temp Sensor Voltage (+5V max)
- TD = Temp Sensor Data
- TG = Temp Sensor Ground
- CT = Current Transformer
- CT = Current Transformer