

EASTOTM
PNEUMATIC
The Better Comfort

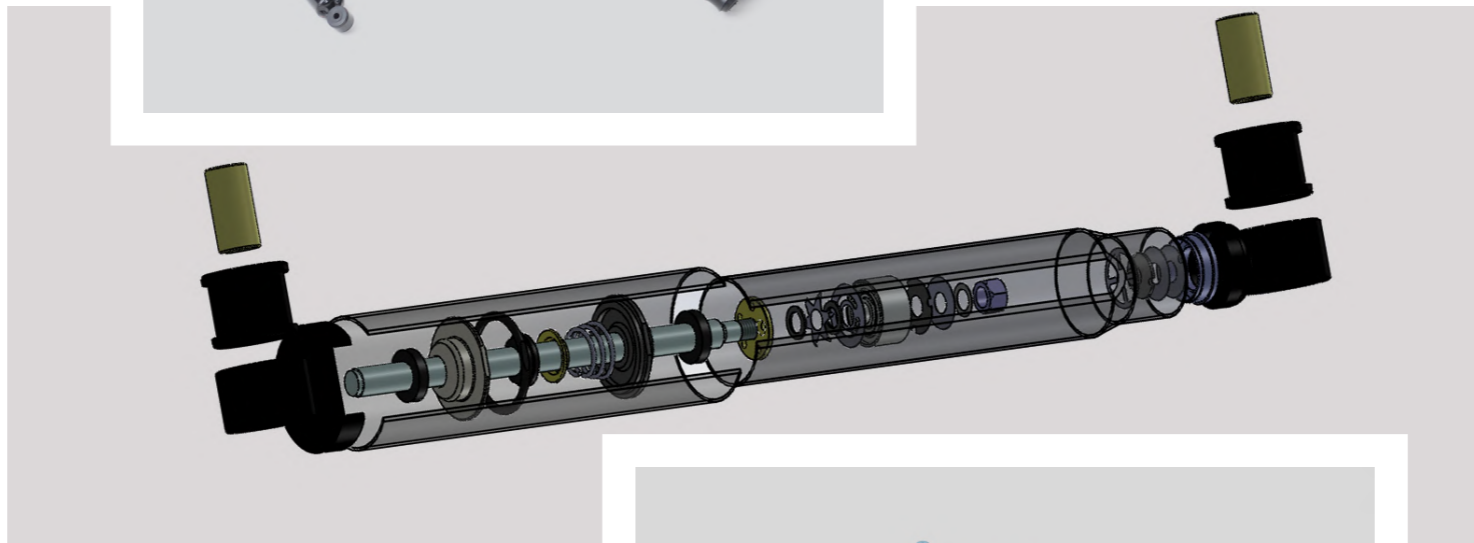

Easto Pneumatic

We, the proud members of the Easto Pneumatic family, shall strive vigorously to delight our customers who are our very purpose, by pursuing excellence and innovation through committed team work. Easto Pneumatic has made its name in quality and has developed more than 100+ references of shock absorber for domestic as well as international market.



Founded in year 2008 by our MD Mr. Gorakh Rai, our journey started with developing and commercialising pneumatic products and we slowly moved towards shock absorbers for two wheelers, three wheelers and heavy-duty shock absorber for commercial vehicles.

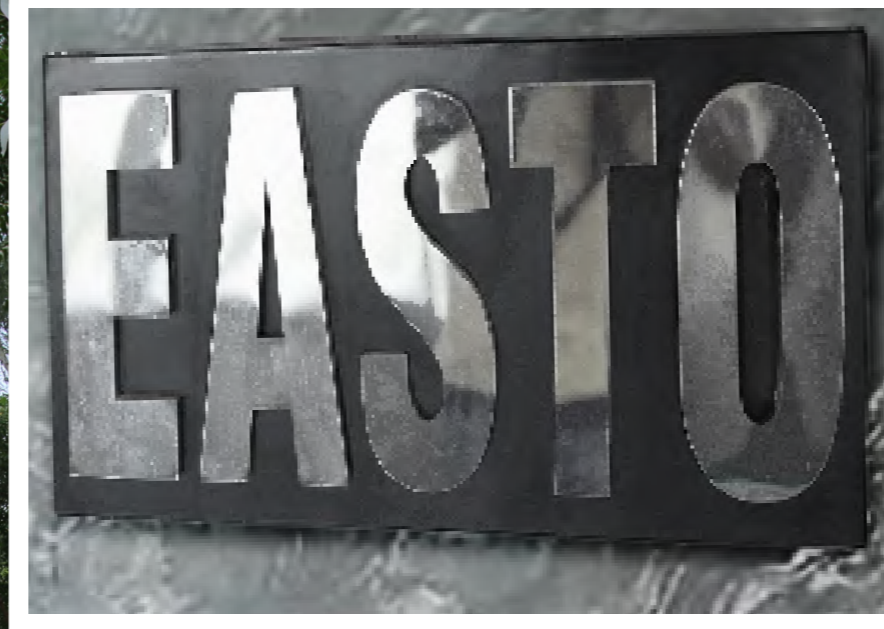

Infrastructure

We have constructed a sound infrastructure facility. The unit is segmented into various parts in order to run all the business activities in a hassle-free manner. These sections are equipped with the latest technology machines. Our infrastructure unit enables us to meet the qualitative and quantitative requirements of our clients. Also, our offered products undergo stringent quality checks under the supervision of the team of high-quality conscious professionals.

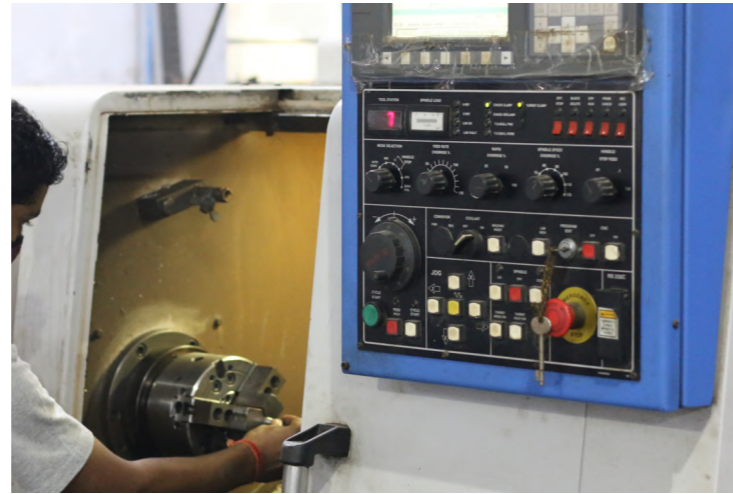



Engineering Capabilities

Easto Pneumatics product engineering and manufacturing capabilities form the cornerstone of everything we offer. We utilize the latest computer-aided designs and lean manufacturing technology and processes to exceed today's stringent demands for both quality and delivery.

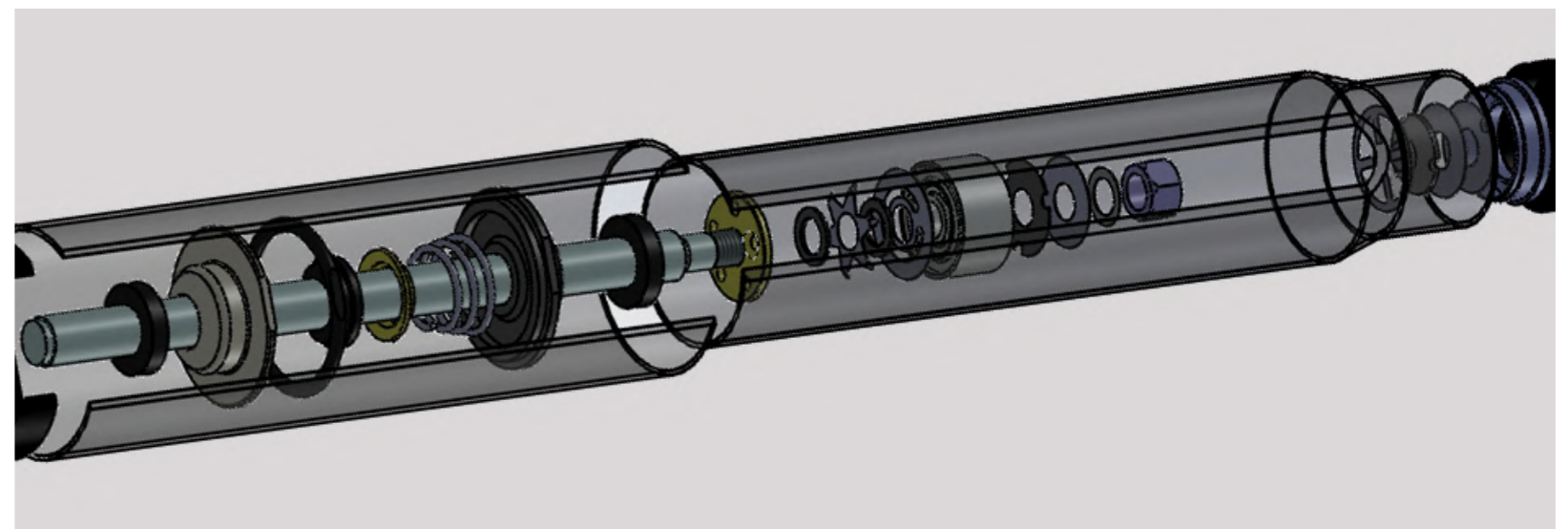
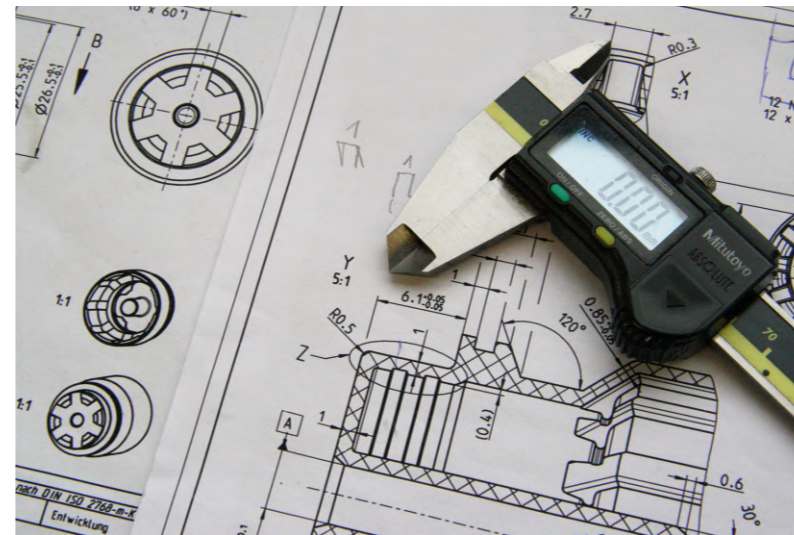

Quality

Our Commitment to quality is unflinching, our hunger for growth is deep-rooted. We have dedicated in-house R&D facility & it is the core competence of Easto Pneumatic. We continuously thrive for our product performance and life expectancy. We have testing machines, latest CAD resources, professionals having more than 25+ years of experience.

We continue to invest in research and development, manufacturing technology and people who are dedicated to delivering precision manufactured and innovative products.



Endurance Testing Machine

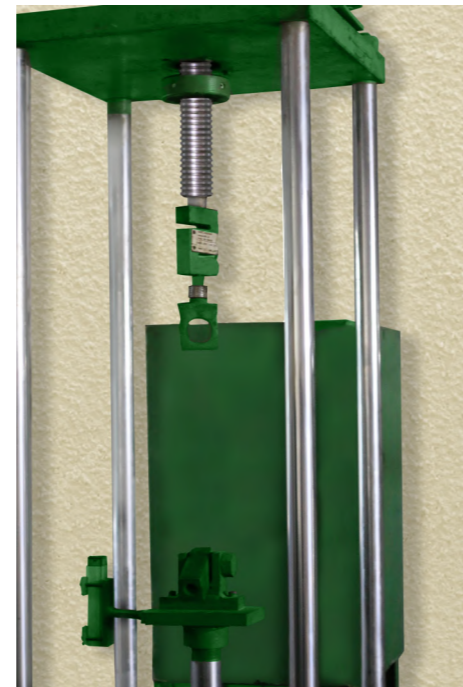

Performance Testing Machine



Universal Testing Machine



Products

Our product ranges vary from Shock Absorbers to Pneumatic items such as cabin shockers, seat shockers, three-wheeler, two-wheeler, railway shock absorber to hand valve, solenoid valve, pneumatic cylinders.

We cater both domestic as well as international market, we also offer huge range of shock absorbers for European Trucks and trailers that comprehensively cover chassis, cabin and axle applications.

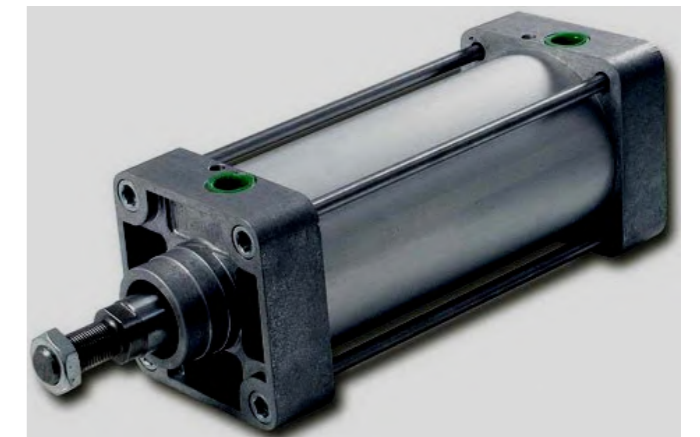

Our Customers



Batra Associates Ltd.



Sietz Technologies India Pvt. Ltd.



Prabha Electronics Pvt. Ltd.

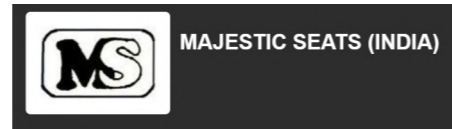

Majestic Seats India



Vee Gee Industrial Enterprises Pvt. Ltd.

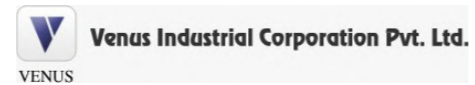

Venus Industries



Wallmax Enterprises



MADHAV EXPOSITION (P) LTD.



Mauria Udyog Limited (Faridabad)



Indus services (Scooter Parts India)



Easto Pneumatic Pvt. Ltd.

16/2 Sareen Complex (Near Badkhal Mor Metro Station),
Mathura Road, Faridabad, Haryana, India -121003

Contact Person:- Suraj Rai

Tel: +91-9555408866

Mail: info@eastogroup.com

Web: eastopneumatic.in