

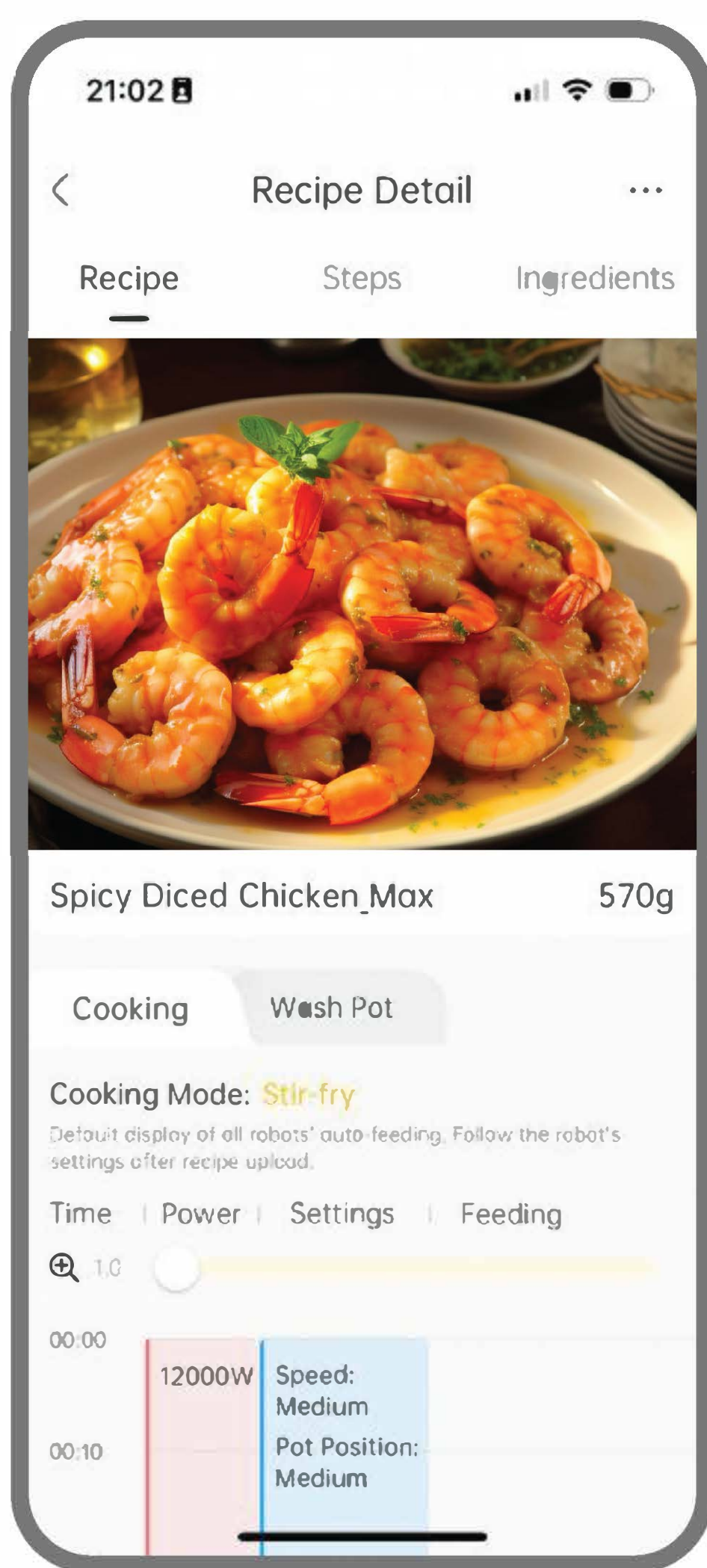

Robot in kitchen

OMNI AUTO-PAN



BOTINKIT APP

MODEL

□ OMNI 1.0

STANDARD FEATURE

- A variety of cooking methods at your fingertips: stir-fry, pan-fry, sauté, boil, braise, mix, stew, simmer, and more.
- Multi-purpose automated processes available to everyone: auto-cooking, auto-seasoning, auto-temperature control, auto-serving, and auto-cleaning
- AI-enabled multilingual voice guide to ensure production is recipe-accurate
- Smartphone and tablet real-time connectivity using the BOTINKIT app
- Multiple Tritan™ customizable seasoning dispenser types: Dry, Liquid, & Oil that are BPA-free and dishwasher safe
- Dual-option configurations including either:
 - 6x liquid seasoning (medium) + 1x self-agitation (large) + 1x Oil
 - 4x liquid seasoning (large) + 3x Oil
- Cooking Capacity:
 - 40 portions (3.5 oz each) in 12 mins Sauté
 - 40 portions (3.5 oz each) in 6 mins Stir-fry
 - 40 portions (3.5 oz each) in 10 mins Braise
- MAD (multi-sensor auto-learning dispenser) spice delivery system ensures accurate, consistent, recipe-exact production during every meal period.
- One-click calibration: precision scale and sensors eliminate the need for complex processes with a single calibration click option.
- On-The-Fly recipe recording function using either the 8" HD LCD touchscreen display or any smart-enabled device
- Intelligent Temp. Control: flexible power adjustments for precise temperature control up to 350°C (662°F)
- Multi-speed production motors, multi-level pot height adjustment, clockwise and counter-clockwise operation options

Supported Seasoning Types Dry, Sauce, Liquid, Oil

Maximum Simultaneous Seasoning Types 13 Types

Wok Capacity 30L (7.93gal)

Maximum Cooking Temperature Nitrided Iron Pot 350°C (662°F)

Heating Rate 8°C (14.4°F) per second

OPTIONAL ACCESSORIES

- SLD01 Small Tritan™ Liquid Dispenser: 23.67 fluid oz. (700ml)
- LLD01 Large Tritan™ Liquid Dispenser: 47.34 fluid oz. (1400ml)
- DHB01 1.5" drain hub (38.1mm)

PRODUCT DIMENSIONS & NET WEIGHT

	Dimensions: Width × Depth × Height <small>*Includes anti-collision handle and water gun hook</small>	Weight
Overall /Weight	32.76in × 36.22in × 69.65in 832mm × 970mm × 1768mm	396.83lb 180kg
Main Body /Weight	32.76in × 27.52in × 38.66in 832mm × 699mm × 981mm	264.55lb 120kg
Base /Weight	31.26in × 38.19in × 31.00in 794mm × 970mm × 787mm	132.28lb 60kg

INCOMING UTILITY REQUIREMENTS

Incoming Water: 19.05 mm (3/4" male NSHT, 30-50 PSI required)

Drain: 38.1mm (1.5") diameter drain hub

Electrical: Terminal block available for professional field installation. Please refer to the NEC, state and local codes prior to install.

Screen: 8-inch capacitive touchscreen

Hood: Type 1 hood required with sustained 1000 CFM minimum draw

Seasoning Box Capacity:

Dry/Sauce Seasoning Box: 21.97 fl oz (650ml)

Small Liquid Seasoning Box: 23.67 fl oz (700ml)

Large Liquid Seasoning Box: 47.34 fl oz (1400ml),

Roux Box: 47.34 fl oz (1400ml)

Voltage	Phase	KW
208/240V	3	10.0/12.0/15.0

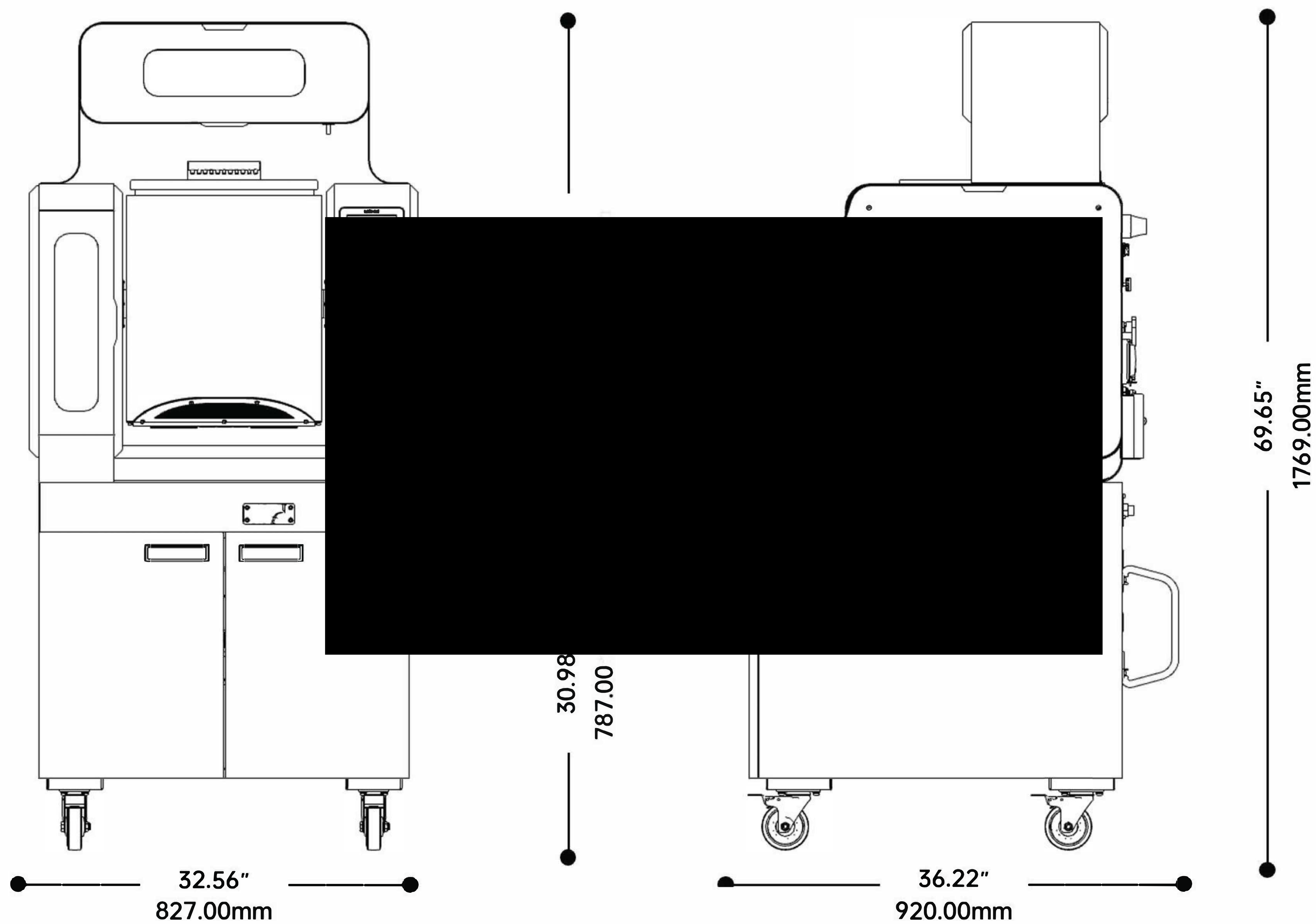

MACHINE WEIGHT: 180 KG (397 lbs)

SHIPPING WEIGHT: 303 KG (667 lbs)

INSTALLATION AND MAINTENANCE SAFETY

The BOTINKIT Omni must be installed, cleaned, and maintained in accordance with the guidelines provided in the Installation and Operations Manuals furnished with the unit. It is the responsibility of the owner and installer to ensure compliance with all applicable local codes and regulations.

Please note that while a water supply may be classified as potable, this does not guarantee that it is properly treated for use. As with all commercial equipment using domestic water, the BotInKit Omni is vulnerable to damage and performance issues caused by chemical and mineral content present in water. To protect your investment, it is strongly recommended to use an appropriate water treatment system, perform routine filter replacements, and regularly de-lime the unit.

Damage resulting from poor water quality or from a lack of required owner/operator maintenance is solely the responsibility of the owner/operator and is not covered under warranty.

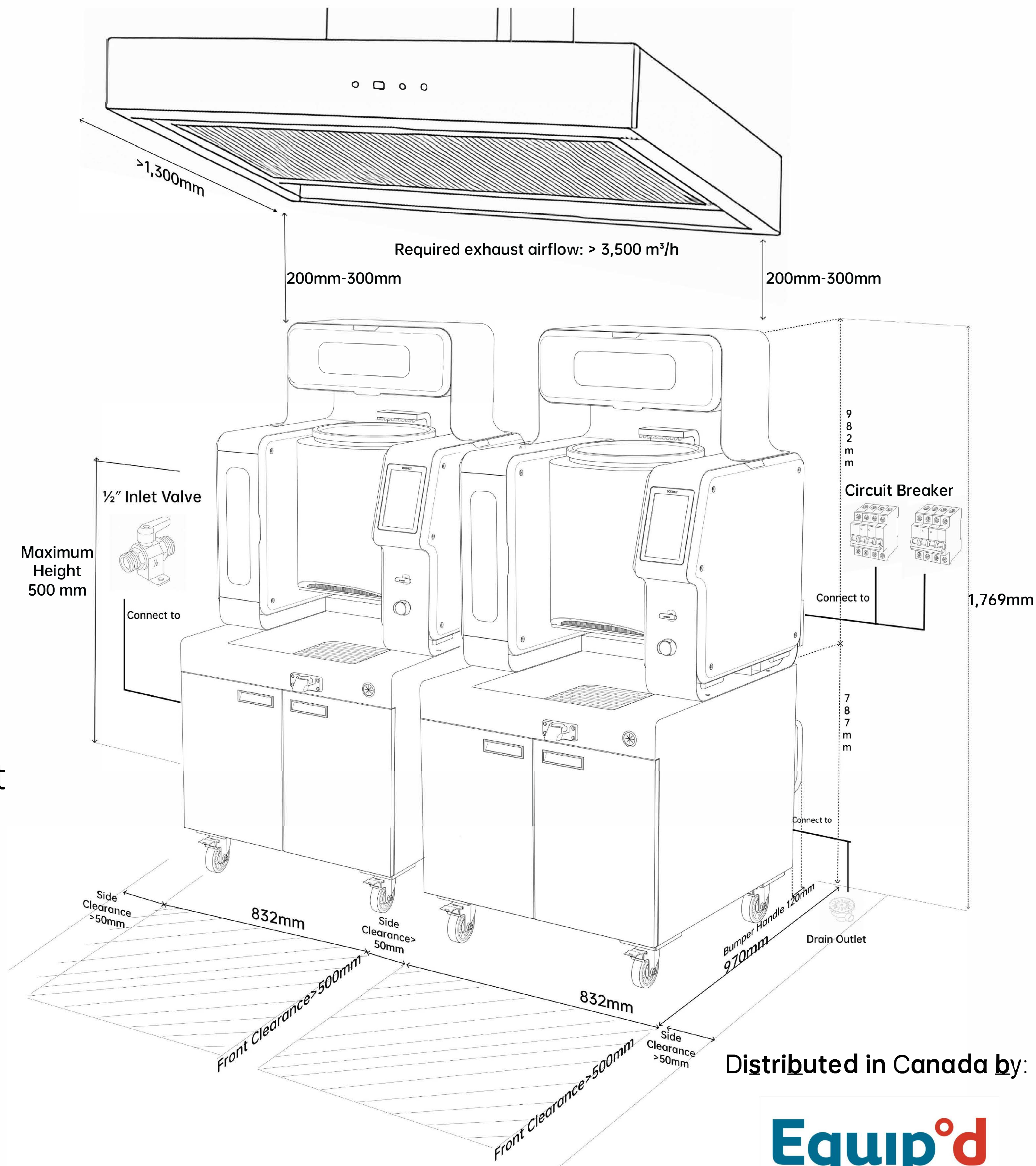

Distributed in Canada by:

