

**OKEECHOBEE UTILITY AUTHORITY**  
**MEETING AGENDA**  
**NOVEMBER 21, 2023**  
**8:30 A.M.**

1. Call the Meeting to Order
  - Pledge of Allegiance
  - Determination of Voting Members
2. Agenda Additions or Deletions
3. Meeting Minutes from October 17, 2023
4. Department Supervisor Updates
- 5. Consent Agenda**
  6. Invoice from Sumner Engineering & Consulting, Inc. – SW 5<sup>th</sup> Avenue LPSS Design & Permitting
  7. Invoice from Sumner Engineering & Consulting, Inc. – Okee-Tantie Utility System Improvements
  8. Invoice from Hinterland Group, Inc – SWSA Project 2
  9. Invoice from Lewis Longman Walker – USDA Loan
  10. Invoice from Hinterland – Pine Ridge Park Utility Improvements
  11. Invoices from Kimley Horn and Associates, Inc. – Treasure Island Septic to Sewer Project
  12. Invoice from Thorn Run Partners
  13. Invoice from MacVicar Consulting, Inc. – Lake Okeechobee System Operating Manual

---
14. Customer Water Loss
15. Finance Report
16. Salary Analysis & Benefits Survey – Evergreen Solution
17. State Road 78W 24-Inch Water Main State Project
18. WWTF for NE Glades County – Feasibility Report
19. Security Camera SWTP
20. Cemetery Road WWTF Entrance Road Paving
21. SWTP Update
22. Safety Committee Meeting
23. Public Comments

24. Items from the Attorney
25. Items from the Executive Director
26. Items from the Board

**OKEECHOBEE UTILITY AUTHORITY**

AGENDA ITEM NO. 1

NOVEMBER 21, 2023

Call Meeting to Order

Pledge of Allegiance  
Determine Voting Members

	<u>Absent</u>	<u>Present</u>
Melanie Anderson – Alternate	_____	_____
Tommy Clay – Board Member	_____	_____
John Gilliland – Board Member	_____	_____
Harry Moldenhauer – Board Member	_____	_____
Steve Nelson – Board Member	_____	_____
Glenn Sneider - Alternate	_____	_____
Tabitha Trent – Board Member	_____	_____
Vacant - City Alternate	_____	_____

**FUTURE MEETING OF OUA BOARD**

**December 19, 2023 – 8:30 A.M.**

**FUTURE HOLIDAYS FOR OUA STAFF**

**Thursday – November 23, 2023 – Thanksgiving Day**

**Monday – December 25, 2023 – Christmas Day**

**OKEECHOBEE UTILITY AUTHORITY**

AGENDA ITEM NO. 2

NOVEMBER 21, 2023

**AGENDA ADDITIONS OR DELETIONS**

**OKEECHOBEE UTILITY AUTHORITY**

AGENDA ITEM NO. 3

NOVEMBER 21, 2023

**MEETING MINUTES**

Attached are copies of the minutes from the meeting held on October 17, 2023.

**Unless the Board determines a correction is required to the minutes, Staff recommends the approval of the meeting minutes from October 17, 2023 as presented.**

**OKEECHOBEE UTILITY AUTHORITY  
MEETING MINUTES**

Tuesday, October 17, 2023 8:30 A.M.

Okeechobee Utility Authority

100 SW 5<sup>th</sup> Avenue

Okeechobee, Florida

**Vice Chairperson Trent called the meeting to order at 8:31 A.M.**

**Vice Chairperson Trent determined the voting members and led all participating attendees and visitors in the Pledge of Allegiance.**

**Vice Chairperson Trent addressed Agenda Item No. 1**, the following Okeechobee Utility Authority Board Members were present:

**Board Members:**

John Gilliland\*

Harry Moldenhauer\*

Tabitha Trent\*

**Alternates:**

Melanie Anderson

Glenn Sneider\*\*

**Absent:**

Tommy Clay

Steven Nelson

\*Voting Board Members

\*\* Voting in Tommy Clay's absence

**OUA Members:**

John Hayford

Lauriston Hamilton

Jamie Mullis

Tom Conely

Michelle Willoughby

**Vice Chairperson Trent addressed Agenda Item No. 2 'Agenda Additions or Deletions'** Executive Director Hayford discusses that Agenda Item No. 14 has an error. The last line of the item should read "Staff recommends approval of this invoice in the amount of \$25,688.60 to Kimley Horn and Associates, Inc. "

**Vice Chairperson Trent addressed Agenda Item No. 3 'Meeting Minutes from September 19, 2023'. Motion by Harry Moldenhauer to accept the Meeting Minutes from September 19, 2023 as presented. Second by John Gilliland. Vote unanimous (4-0), motion carried.**

**Vice Chairperson Trent addressed Agenda Item No. 4 'Department Supervisor Updates'**

Maintenance: Jess Manson gave an update on the Maintenance Department. Advised that the Maintenance Department is fully staffed at this time. *Steven Nelson in at 8:33AM.* Jess Manson discusses that staff morale is high at this time. Board Member Nelson asked about cleaning and painting fire hydrants. Jess Manson discusses what the colors of the hydrants means (i.e. Green, highest pressure)

SWTP: Kevin Rogers advises the board that the department is fully staffed. Advises that presently one operator needs to pass testing. Advises that other employees still need to meet time requirements to take

certification test. Kevin Rogers advises the board that he is stilling working on a chiller system for Ozone. Advises the board that a quote was received the night before and it needs to be reviewed.

WWTP: Jamie Gamiotea gave an update of the WWTP. Advised that one employee left to take employment with the Seminole Tribe of Florida. This employee is staying on part time to work weekends.

Administration: Kristy Arnold was not present

Jamie Mullis gave an overall update of all departments.

**Vice Chairperson Trent addressed Agenda Item No. 5 ‘Consent Agenda’ Motion by Steven Nelson to approve the Consent Agenda as corrected:**

- Consent Agenda Item No. 6 ‘Invoice from Sumner Engineering & Consulting, Inc – SW Wastewater Service Area Project (Part B & C) in the amount of \$4,922.88’**
- Consent Agenda Item No. 7 ‘Invoice from Sumner Engineering & Consulting, Inc – SW Wastewater Service Area Project (Part E) in the amount of \$25,475.00’**
- Consent Agenda Item No. 8 ‘Invoice from Sumner Engineering & Consulting, Inc – Okee-Tantie Utility System Improvements in the amount of \$17,695.35’**
- Consent Agenda Item No. 9 ‘Invoice from Anderson Andre Consulting Engineers, Inc. – SWSA Project 2 Vacuum Collection System in the amount of \$3,735.50’**
- Consent Agenda Item No. 10 ‘Invoice from CHA – Vacuum Station Number 2 Generator Replacement in the amount of \$7,526.95’**
- Consent Agenda Item No. 11 ‘Invoice from Hinterland Group, Inc. – SWSA Project 2 in the amount of \$590,564.39’**
- Consent Agenda Item No. 12 ‘Invoice from Hinterland Group, Inc – Pine Ridge Park Utility Improvements in the amount of \$244,524.16’**
- Consent Agenda Item No. 13 ‘Invoice from Lewis Longman Walker in the amounts of \$3,467.50’**
- Consent Agenda Item No. 14 ‘Invoice from Kimley Horn and Associates, Inc. – Treasure Island Septic to Sewer Project in the amount of \$25,688.60’**
- Consent Agenda Item No. 15 ‘Invoice from Evergreen Solutions, LLC in the amount of \$4,875.00’**
- Consent Agenda Item No. 16 ‘Invoice from Thorn Run Partners in the amount of \$3,500.00’**
- Consent Agenda Item No. 17 ‘Invoice from MacVicar in the amount of \$250.00’**

**Second by Harry Moldenhauer. Vote unanimous (5-0), motion carried.**

**Vice Chairperson Trent Addresses Consent Agenda No. 18 “Customer - Dupelle’** Executive Director Hayford discusses that Mr. Dupelle of 2515 SW 8th Street had a high water read over the July – September 2023 reading period. He used 9,142 gallons during the first month and 47,602 gallons during the second month. Executive Director Hayford discusses that the usage indicates a leak started late in the July-August read period and continued daily into the Aug-September read period. His typical normal bill is in the 3,000 gallon per month range. Executive Director Hayford discusses that a normal monthly bill

is approximately \$35-\$40 per month. The customers August billing went up to approximately \$80 while the September billing is nearly \$350.00. Executive Director Hayford discusses that Mr. Dupelle is present to speak with the OUA Board requesting some consideration for the higher-than-expected bill. Mr. Dupelle speaks to the board about the bills that were higher than he expected. Mr. Dupelle asks the Board to waive all or some of the bill. There was brief discussion. **Motion by Steven Nelson to settle the account for \$175.00. Second by Glenn Sneider.** There was a brief discussion. Steven Nelson withdraws Motion. Glenn Sneider withdraws the second. There was further discussion by other Board members not in favor of reducing the bill. Board Member Sneider suggests that staff reach out to the customer to offer a payment plan for the high bill. No Action Taken

**Chairperson Clay addressed Agenda Item No. 19 ‘Finance Report’** Finance Director Hamilton reviews the Finance Report for period ending September 30, 2023. **Motion by Steven Nelson to accept the Finance Report as presented. Second by Harry Moldenhauer. Vote unanimous (5-0), motion carried.** *Melanie Anderson out at 9:27 AM.*

**Vice Chairperson Trent addressed Agenda Item No. 20 “Commencement of SouthState Bank Interim Finance Agreement’** Executive Director Hayford discusses that at last month’s board meeting, the Board approved the Authority’s establishment of an Interim Financial Agreement with SouthState Bank, which acts as a bridge loan until the formalization/conclusion of USDA loan agreement for the construction of South West Service Area – Septic to Sewer Project. The Authority’s first draw down of \$145,652.87 was also approved by SouthState and was credited to the OUA account on October 12, 2023. Attorney Conley suggests ratification of the execution of the loan documentation by the 2nd Vice Chairperson and approval of the first drawn down. **Motion by Glenn Sneider to ratify the approval of the execution of the loan documentation by the 2<sup>nd</sup> Vice Chairperson. Second by Harry Moldenhauer. Tabitha Trent elected to abstain from voting as a potential conflict of interest. Vote unanimous (4-0), motion carried.**

**Motion by Glenn Sneider to approve the first draw in the amount of \$145,652.87. Second by John Gilliland. Tabitha Trent elected to abstain from voting as a potential conflict of interest. Vote unanimous (4-0), motion carried.**

**Vice Chairperson Trent addressed Agenda Item No. 21 ‘Training Incentive Program Reimbursement’** Executive Director Hayford discusses that the the Safety Committee meets quarterly. The Safety Committee is comprised of selected employees from each department. Executive Director Hayford discusses that to compliment the work of the Safety Committee, the Authority’s insurance company (Preferred Governmental Insurance Trust – PGIT) provides an annual cash incentive up to \$5,000 for safety expenditures incurred above \$10,000 in a given policy year. Executive Director Hayford discusses that during the recent concluded policy year, OUA was credited with checks totaling \$5,047.53 as recognition of safety measures implemented along with the total spent on safety expenditures. Executive Director Hayford discusses that in recognition of staff participation in the safety measures at work, the Board has historically made reimbursements from PGIT available to staff by issuing gift cards to the sum of the refund. **Motion by Steven Nelson allocate the reimbursement to staff including the OUA contribution of \$82.47. Second by Harry Moldenhauer.** *Glenn Sneider out at 9:40 AM.* Board Member Gilliland asks what do the employees do to earn the reimbursement beyond their daily duties. Executive Director Hayford discusses the training experiences that are offered to staff. Board Member Trent discusses that the reimbursement should be utilized for staff training. Board Member Gilliland asks that staff discuss how the reimbursement could be used towards staff training. Executive Director



Hayford discusses that this issue can be discussed at a Safety Committee Meeting and recommendation can be brought back to the board. Steven Nelson withdraws Motion. Harry Moldenhauer withdraws the second. No Action Taken

**Vice Chairperson Trent addressed Agenda Item No. 22 ‘OUA Proposed Employee Bonus Program’**

Executive Director Hayford discusses that consistently over the past years, the OUA has paid a bonus to staff at the Christmas Luncheon. Executive Director Hayford discusses that previous review of Florida State Statute as it relates to payment of bonus, the Authority developed a policy which provides a guide for future bonus payment in order to ensure conformity with F.S. 215.425 Executive Director Hayford discusses that the OUA policy as it pertains to the bonus payment. Executive Director Hayford discusses that given the logistics of coordinating the evaluations of staff members with their supervisors, prior to any such payment, staff is seeking the Board decision on whether a bonus payment will be extended to staff this Christmas. Executive Director Hayford discusses that a provision of 1.5% of employee’s basic salary was included in FY24 budget for the payment. There was a brief discussion. **Motion by Steven Nelson to approve the employee bonus payment for FY24. Second by John Gilliland. Vote unanimous (4-0), motion carried.**

**Motion by Steven Nelson to extend bonus payment of 1.5%. Second by John Gilliland. Vote unanimous (4-0), motion carried.**

**Vice Chairperson Trent addressed Agenda Item No. 23 ‘Salary Analysis & Benefits Survey – Evergreen Solutions’** Executive Director Hayford discusses that Evergreen Solutions provided a draft report. There was an internal meeting with OUA staff and a board representation to discuss the draft report. There were some questions and concerns raised during the internal meeting. Executive Director Hayford discusses a second meeting in the form of a conference call was subsequently held on Wednesday October 11th where additional questions for clarification were presented to Evergreen which now necessitates further analysis of the working progress file. There was a brief discussion. This is for informational purposes only.

**Vice Chairperson Trent addressed Agenda Item No. 24 ‘Surplus Vehicles’** Executive Director Hayford discusses the board recently approved the purchase of vehicles for the meter reading, water plant and maintenance departments. Executive Director Hayford discusses that staff have received five of the seven units. Executive Director Hayford requests that three vehicles (2006 Ford F250, 2015 Ford F150 and 1999 GMC) be deemed as surplus. **Motion by Harry Moldenhauer to declare the three vehicles presented as surplus and authorize staff to sell vehicles. Second by Steven Nelson. Vote unanimous (4-0), motion carried.**

**Vice Chairperson Trent addressed Agenda Item No. 25 ‘Public Comments’** There were none.

**Vice Chairperson Trent addressed Agenda Item No. 26 ‘Items from the Attorney’** Attorney Conley discusses that he is still missing OUA Board Evaluations of the Executive Director. Attorney Conley advises the board that the Franchise Agreement with Glades County has been submitted to Glades County for review.

**Vice Chairperson Trent addressed Agenda Item No. 27 ‘Items from the Executive Director’** Executive Director Hayford gave an update on current projects.

**Vice Chairperson Trent addressed Agenda Item No. 28 ‘Items from the Board’** Board Member

Moldenhauer asks staff about the allocation of water from Lake Okeechobee. Executive Director Hayford discusses that staff is working on data research for reporting that needs to be submitted to SFWMD.

Board Member Nelson advises the board that he is following up with Connie Vanassche about funding for the AMI system and the home to street connections for scheduled projects.

**Motion by Steven Nelson to adjourn meeting at 10:10 A.M. Second by John Gilliland. Vote unanimous (4-0), motion carried.**

**There being no other business, meeting adjourned at 10:10 A.M.**

PLEASE TAKE NOTICE AND BE ADVISED that if a person decided to appeal any decision made by the Okeechobee Utility Authority with respect to any matter considered at this meeting, he/she may need to ensure that verbatim record of the proceeding is made, which record includes the testimony and evidence upon which the appeal is to be based. A video recording of this meeting is on file in the Executive Director's office.

---

Chairperson

---

Executive Director (Secretary)

DRAFT

**OKEECHOBEE UTILITY AUTHORITY**

AGENDA ITEM NO. 4

NOVEMBER 21, 2023

**DEPARTMENT SUPERVISOR UPDATES**

# **OKEEHOBEE UTILITY AUTHORITY**

## **AGENDA ITEM NO. 5**

**NOVEMBER 21, 2023**

### **CONSENT AGENDA**

1. Pull items for discussion from Consent Agenda.
2. Items pulled from Consent Agenda will be discussed at the end of Agenda.
3. Unless noted all Consent Agenda items are recommended for approval.
4. Motion to approve items on Consent Agenda as follows:
  6. Invoice from Sumner Engineering & Consulting, Inc. – SW 5<sup>th</sup> Avenue LPSS Design & Permitting
  7. Invoice from Sumner Engineering & Consulting, Inc. – Okee-Tantie Utility System Improvements
  8. Invoice from Hinterland Group, Inc. – SWSA Project 2
  9. Invoice from Lewis Longman Walker – USDA Loan
  10. Invoice from Hinterland – Pine Ridge Park Utility Improvements
  11. Invoices from Kimley Horn and Associates, Inc. – Treasure Island Septic to Sewer Project
  12. Invoice from Thorn Run Partners
  13. Invoice from MacVicar Consulting, Inc. – Lake Okeechobee System Operating Manual

**OKEECHOBEE UTILITY AUTHORITY**

AGENDA ITEM NO. 6

NOVEMBER 21, 2023

**CONSENT AGENDA**

**INVOICE FROM SUMNER ENGINEERING & CONSULTING, INC. – SW 5<sup>th</sup> AVENUE  
LPSS DESIGN AND PERMITTING**

Please find attached the invoice in the amount of \$22,808.80 submitted by Sumner Engineering & Consulting, Inc. Staff is aware of the work currently being done by Sumner Engineering & Consulting, Inc. and is in agreement with this request.

Invoice Date	Pay Request No.	Date Paid	Amt. Requested	Amount Paid	Remaining Balance
					\$325,840.00
Nov-23	1		\$22,808.80		\$303,031.20

**Staff recommends approval of this invoice in the amount of \$22,808.80 to Sumner Engineering & Consulting, Inc.**



## Invoice

BILL TO

November 10, 2023

Okeechobee Utility Authority  
100 SW 5th Avenue  
Okeechobee, Florida 34974

Invoice No. 1612  
SW 5<sup>th</sup> Avenue LPSS Design and Permitting (SEC Proj. No. 20-10)  
**OUA Purchase Order No. 11129 / 11633**

Task	Contract Amount	Percent Complete	Amount Complete	Previously Billed	Invoice Amount
B1 – Design and Permitting	\$198,500	93%	\$184,605.00	\$184,605.00	\$0.00
D1 – VSS Design & Permitting	\$325,840	7%	\$22,808.80	\$0.00	\$22,808.80
				<b>TOTAL:</b>	<b>\$22,808.80</b>

Total Purchase Order Amount: \$524,340.00  
Total Billed to Date: \$207,413.80  
**Total Billed this Invoice: \$ 22,808.80**

For services rendered January 1 – November 4, 2023.

**OKEECHOBEE UTILITY AUTHORITY**

AGENDA ITEM NO. 7

NOVEMBER 21, 2023

**CONSENT AGENDA**

**INVOICE FROM SUMNER ENGINEERING & CONSULTING, INC. – OKEE-TANTIE  
UTILITY SYSTEM IMPROVEMENTS**

Please find attached the invoice in the amount of \$42,727.81 submitted by Sumner Engineering & Consulting, Inc. Staff is aware of the work currently being done by Sumner Engineering & Consulting, Inc. and is in agreement with this request.

Invoice Date	Pay Request No.	Date Paid	Amt. Requested	Amount Paid	Remaining Balance
					\$686,079.00
Apr-22	1	Apr-22		\$29,835.00	\$656,244.00
May-22	2	May-22		\$3,817.50	\$652,426.50
Jun-22	3	Jun-22		\$94,920.00	\$557,506.50
Jul-22	4	Jul-22		\$11,398.50	\$546,108.00
Aug-22	5	Aug-22		\$9,440.00	\$536,668.00
Oct-22	6	Oct-22		\$7,996.00	\$528,672.00
Jan-23	7	Jan-23		\$10,668.00	\$518,004.00
Feb-23	8	Feb-23		\$3,199.44	\$514,804.56
Mar-23	9	Mar-23		\$31,994.40	\$482,810.16
Apr-23	10	Apr-23		\$15,997.20	\$466,812.96
Apr-23	Change Order		\$145,365.00		\$612,177.96
May-23	11	May-23		\$13,548.06	\$598,629.90
Jun-23	12	Jun-23		\$51,791.28	\$546,838.62
Aug-23	13	Aug-23		\$4,549.94	\$542,288.68
Sep-23	14	Sep-23		\$30,445.58	\$511,843.10
Oct-23	15	Oct-23		\$17,695.35	\$494,147.75
Nov-23	16		\$42,727.81		\$451,419.94

**Staff recommends approval of this invoice in the amount of \$42,727.81 to Sumner Engineering & Consulting, Inc.**



# Invoice

BILL TO

November 3, 2023

Okeechobee Utility Authority  
100 SW 5th Avenue  
Okeechobee, Florida 34974

Invoice No. 1610  
Okee-Tantie Utility System Improvements (SEC Proj. No. 21-11)  
**OUA Purchase Order No. 11130**

Task	Contract Amount	Percent Complete	Amount Complete	Previously Billed	Invoice Amount
<b>A1 – Preliminary Modeling and Technical Memo</b>	\$36,100.00	100%	\$36,100.00	\$36,100.00	<b>\$0.00</b>
<b>A2 – Route Survey and Preliminary (10%) Design</b>	\$129,050.00	100%	\$129,050.00	\$129,050.00	<b>\$0.00</b>
<b>A3 – Pre-Application Meetings and Summary Memo</b>	\$5,850.00	58%	\$3,393.00	\$3,393.00	<b>\$0.00</b>
<b>B1 – Design and Permitting</b>	\$431,594.00	49%	\$211,481.06	\$168,753.25	<b>\$42,727.81</b>
• <i>Original Authorization</i>	\$319,944.00				
• <i>Change Order</i>	\$111,650.00				
<b>B2 – Bidding Services</b>	\$17,010.00	0%	\$0.00	\$0.00	<b>\$0.00</b>
• <i>Original Authorization</i>	\$13,765.00				
• <i>Change Order</i>	\$3,245.00				
<b>C1 – Construction Administration</b>	\$211,840.00	0%	\$0.00	\$0.00	<b>\$0.00</b>
• <i>Original Authorization</i>	\$181,370.00				
• <i>Change Order</i>	\$30,470.00				
				<b>TOTAL:</b>	<b>\$42,727.81</b>

Total Purchase Order Amount: \$831,444.00  
Total Billed to Date: \$380,024.06  
**Total Billed this Invoice: \$ 42,727.81**

For services rendered October 1 - 28, 2023.



**OKEECHOBEE UTILITY AUTHORITY**

AGENDA ITEM NO. 8

NOVEMBER 21, 2023

**CONSENT AGENDA**

**INVOICE FROM HINTERLAND GROUP, INC. – SWSA PROJECT 2**

Please find attached invoice in the amounts of \$372,055.78 submitted by Hinterland Group, Inc. Staff is aware of the work currently being done by Hinterland Group, Inc. and is in agreement with this request.

Invoice Date	Pay Request No.	Date Paid	Amt. Requested	Retainage	Amount Paid	Remaining Balance
						\$11,954,105.00
Jun-23	1	Jun-23			\$302,829.81	\$11,651,275.19
Jul-23	2	Jul-23			\$559,224.49	\$11,092,050.70
Aug-23	3	Aug-23			\$1,064,874.13	\$10,027,176.57
Sep-23	4	Sep-23			\$882,815.44	\$9,144,361.13
Oct-23	5	Oct-23			\$590,564.39	\$8,553,796.74
Nov-23	6		\$372,055.78	\$198,545.48		\$7,983,195.48

**Staff recommends approval of these invoice in the amounts of \$372,055.78 to Hinterland Group, Inc.**



November 13, 2023

Okeechobee Utility Authority  
100 SW 5<sup>th</sup> Avenue  
Okeechobee, FL 34974

**RE: SWSA Project 2 – Vacuum Collection System  
Hinterland Group, Inc. – Pay Application No. 6**

Mr. Hayford:

Please find attached Pay Application No. 6 for the above-referenced project, recommended for payment in the amount of \$372,055.78, which covers work confirmed to have been completed for the period from October 1 – November 3, 2023, less the required 5% retainage. In support of our recommendation for payment, we have attached our daily RPR logs for the month, and a Monthly Summary Report, along with other supporting documentation from the contractor (Consent of Surety, etc.).

If you have any questions, please do not hesitate to contact us.

Sincerely,  
**Sumner Engineering & Consulting, Inc.**

Jeffrey M. Sumner, PE  
President

**Contractor's Application for Payment**

<b>Owner:</b> <u>Okeechobee Utility Authority</u>	<b>Owner's Project No.:</b> _____
<b>Engineer:</b> <u>Sumner Engineering &amp; Consulting, Inc.</u>	<b>Engineer's Project No.:</b> <u>19-04.E</u>
<b>Contractor:</b> <u>Hinterland Group, Inc.</u>	<b>Contractor's Project No.:</b> <u>22-0234-00</u>
<b>Project:</b> <u>Southwest Wastewater Service Area - Project 2</u>	
<b>Contract:</b> <u>235-006.03</u>	
<b>Application No.:</b> <u>6</u>	<b>Application Date:</b> <u>11/10/2023</u>
<b>Application Period:</b> From <u>10/1/2023</u> to <u>11/3/2023</u>	

1. Original Contract Price	\$ 11,954,105.00
2. Net change by Change Orders	\$ -
3. Current Contract Price (Line 1 + Line 2)	\$ 11,954,105.00
4. Total Work completed and materials stored to date (Sum of Column G Lump Sum Total and Column J Unit Price Total)	\$ 3,970,909.52
5. Retainage	
a. <u>5%</u> X \$ <u>3,101,465.90</u> Work Completed	\$ 155,073.30
b. <u>5%</u> X \$ <u>869,443.62</u> Stored Materials	\$ 43,472.18
c. Total Retainage (Line 5.a + Line 5.b)	\$ 198,545.48
6. Amount eligible to date (Line 4 - Line 5.c)	\$ 3,772,364.04
7. Less previous payments (Line 6 from prior application)	\$3,400,308.26
8. Amount due this application	\$ 372,055.78
9. Balance to finish, including retainage (Line 3 - Line 4)	\$ 7,983,195.48

**Contractor's Certification**

The undersigned Contractor certifies, to the best of its knowledge, the following:

- (1) All previous progress payments received from Owner on account of Work done under the Contract have been applied on account to discharge Contractor's legitimate obligations incurred in connection with the Work covered by prior Applications for Payment;
- (2) Title to all Work, materials and equipment incorporated in said Work, or otherwise listed in or covered by this Application for Payment, will pass to Owner at time of payment free and clear of all liens, security interests, and encumbrances (except such as are covered by a bond acceptable to Owner indemnifying Owner against any such liens, security interest, or encumbrances); and
- (3) All the Work covered by this Application for Payment is in accordance with the Contract Documents and is not defective.

**Contractor:** Josh Ramirez

**Signature:**  **Date:** 11/13/2023

**Recommended by Engineer:** Jeffrey M Sumner

**Approved by Owner:** Tommy Clay

**By:** \_\_\_\_\_

**By:** \_\_\_\_\_

**Title:** President

**Title:** Chairman

**Date:** 11/13/23

**Date:** 11/21/23

**Approved by Funding Agency**

**By:** \_\_\_\_\_

**By:** \_\_\_\_\_

**Title:** \_\_\_\_\_

**Title:** \_\_\_\_\_

**Date:** \_\_\_\_\_

**Date:** \_\_\_\_\_

**Progress Estimate - Lump Sum Work**

**Contractor's Application for Payment**

<b>Owner:</b>	Okeechobee Utility Authority	<b>Owner's Project No.:</b>	
<b>Engineer:</b>	Summer Engineering & Consulting, Inc.	<b>Engineer's Project No.:</b>	19-04.E
<b>Contractor:</b>	Hinterland Group, Inc.	<b>Contractor's Project No.:</b>	22-0234-00
<b>Project:</b>	Southwest Wastewater Service Area - Project 2		
<b>Contract:</b>	235-006.03		

**Application No.:** 6      **Application Period:** From 10/01/23 to 11/03/23      **Application Date:** 11/10/23

A	B	C	D	E	F	G	H	I
Item No.	Description	Scheduled Value (\$)	Work Completed		Materials Currently Stored (not in D or E) (\$)	Work Completed and Materials Stored to Date (D + E + F) (\$)	% of Scheduled Value (G / C) (%)	Balance to Finish (C - G) (\$)
			(D + E) From Previous Application (\$)	This Period (\$)				

**Original Contract**

**General**

1	Mobilization	\$ 775,000.00	277,708.32	20,989.58		298,697.90	39%	476,302.10
2	Indemnification	\$ 214,000.00	214,000.00	-		214,000.00	100%	-
3	As-Built Record Drawings	\$ 100,000.00	10,000.00	-		10,000.00	10%	90,000.00
4	Maintenance of Traffic	\$ 105,000.00	41,850.00	5,250.00		47,100.00	45%	57,900.00
5	Existing Utility Location / Identification	\$ 30,000.00	12,000.00	1,500.00		13,500.00	45%	16,500.00
6	NPDES General Construction Permit Compliance	\$ 35,000.00	14,000.00	1,750.00		15,750.00	45%	19,250.00

**Vacuum Pump Station No. 4**

10a	Excavation and Dewatering	\$80,000.00	64,000.00	8,000.00		72,000.00	90%	8,000.00
10b	Building Shell	\$365,000.00	85,000.00	86,000.00		171,000.00	47%	194,000.00
10c	Roof	\$45,000.00				-	0%	45,000.00
10d	Overhead Bridge Hoist	\$65,000.00			14,868.00	14,868.00	23%	50,132.00
10e	Miscellaneous (Gutters, Hose Bibs, Lights, etc)	\$45,000.00				-	0%	45,000.00
10f	Generator	\$200,000.00				-	0%	200,000.00
10g	Electrical (Equipment only)	\$65,000.00				-	0%	65,000.00
10h	Electrical (Conduits, Wire, Labor, etc.)	\$150,000.00		22,500.00	6,867.30	29,367.30	20%	120,632.70
10i	Vacuum Skids (Vacuum Pumps, Tank, and	\$525,000.00			237,500.00	237,500.00	45%	287,500.00
10j	Interior Piping	\$65,000.00				-	0%	65,000.00
10k	Yard Piping and Valves	\$25,000.00				-	0%	25,000.00
10l	Interior / Exterior Finishes	\$30,000.00				-	0%	30,000.00
10m	HVAC	\$40,000.00				-	0%	40,000.00
10n	Louvers and Metalwork	\$7,500.00				-	0%	7,500.00
10o	Odor Control	\$15,000.00				-	0%	15,000.00
10p	Plumbing	\$8,500.00				-	0%	8,500.00
10q	Bathroom	\$7,500.00				-	0%	7,500.00
10r	Doors	\$25,000.00				-	0%	25,000.00
10s	Concrete Drive	\$65,000.00				-	0%	65,000.00
10t	Underdrain	\$20,000.00				-	0%	20,000.00
10u	General Sitework (Clearing, Grading, etc.)	\$81,500.00	67,050.00	6,520.00		73,570.00	90%	7,930.00

**Vacuum Pump Station No. 5**

11a	Excavation and Dewatering	\$80,000.00				-	0%	80,000.00
11b	Building Shell	\$365,000.00				-	0%	365,000.00

**Progress Estimate - Lump Sum Work**

**Contractor's Application for Payment**

<b>Owner:</b>	Okeechobee Utility Authority	<b>Owner's Project No.:</b>	
<b>Engineer:</b>	Summer Engineering & Consulting, Inc.	<b>Engineer's Project No.:</b>	19-04.E
<b>Contractor:</b>	Hinterland Group, Inc.	<b>Contractor's Project No.:</b>	22-0234-00
<b>Project:</b>	Southwest Wastewater Service Area - Project 2		
<b>Contract:</b>	235-006.03		

Application No.: 6 Application Period: From 10/01/23 to 11/03/23 Application Date: 11/10/23

A	B	C	D		E	F	G	H	I
Item No.	Description	Scheduled Value (\$)	Work Completed		Materials Currently Stored (not in D or E) (\$)	Work Completed and Materials Stored to Date (D + E + F) (\$)	% of Scheduled Value (G / C) (%)	Balance to Finish (C - G) (\$)	
			(D + E) From Previous Application (\$)	This Period (\$)					
11c	Roof	\$45,000.00				-	0%	45,000.00	
11d	Overhead Bridge Hoist	\$65,000.00			14,868.00	14,868.00	23%	50,132.00	
11e	Miscellaneous (Gutters, Hose Bibs, Lights, etc)	\$45,000.00				-	0%	45,000.00	
11f	Generator	\$200,000.00				-	0%	200,000.00	
11g	Electrical (Equipment only)	\$65,000.00				-	0%	65,000.00	
11h	Electrical (Conduits, Wire, Labor, etc.)	\$150,000.00			6,867.30	6,867.30	5%	143,132.70	
11i	Vacuum Skids (Vacuum Pumps, Tank, and	\$525,000.00				-	0%	525,000.00	
11j	Interior Piping	\$65,000.00				-	0%	65,000.00	
11k	Yard Piping and Valves	\$25,000.00				-	0%	25,000.00	
11l	Interior / Exterior Finishes	\$30,000.00				-	0%	30,000.00	
11m	HVAC	\$40,000.00				-	0%	40,000.00	
11n	Louvers and Metalwork	\$7,500.00				-	0%	7,500.00	
11o	Odor Control	\$15,000.00				-	0%	15,000.00	
11p	Plumbing	\$8,500.00				-	0%	8,500.00	
11q	Bathroom	\$7,500.00				-	0%	7,500.00	
11r	Doors	\$25,000.00				-	0%	25,000.00	
11s	Concrete Drive	\$65,000.00				-	0%	65,000.00	
11t	Underdrain	\$20,000.00				-	0%	20,000.00	
11u	General Sitework (Clearing, Grading, etc.)	\$81,500.00				-	0%	81,500.00	
<b>Restoration</b>									
13	Pavement Markings	\$58,000.00				-	0%	58,000.00	
						-		-	
						-		-	
						-		-	
<b>Original Contract Totals</b>		<b>\$ 5,177,000.00</b>	<b>\$ 785,608.32</b>	<b>\$ 152,509.58</b>	<b>\$ 280,970.60</b>	<b>\$ 1,219,088.50</b>	<b>24%</b>	<b>\$ 3,957,911.50</b>	

<b>Change Orders</b>									
						-		-	
						-		-	
						-		-	
						-		-	
						-		-	
						-		-	
						-		-	
						-		-	

**Progress Estimate - Lump Sum Work**

**Contractor's Application for Payment**

<b>Owner:</b> Okeechobee Utility Authority		<b>Owner's Project No.:</b> _____
<b>Engineer:</b> Sumner Engineering & Consulting, Inc.		<b>Engineer's Project No.:</b> 19-04.E
<b>Contractor:</b> Hinterland Group, Inc.		<b>Contractor's Project No.:</b> 22-0234-00
<b>Project:</b> Southwest Wastewater Service Area - Project 2		
<b>Contract:</b> 235-006.03		

**Application No.:** 6      **Application Period:** From 10/01/23 to 11/03/23      **Application Date:** 11/10/23

A	B	C	D	E	F	G	H	I
Item No.	Description	Scheduled Value (\$)	Work Completed		Materials Currently Stored (not in D or E) (\$)	Work Completed and Materials Stored to Date (D + E + F) (\$)	% of Scheduled Value (G / C) (%)	Balance to Finish (C - G) (\$)
			(D + E) From Previous Application (\$)	This Period (\$)				
						-		-
						-		-
						-		-
						-		-
						-		-
						-		-
						-		-
						-		-
						-		-
						-		-
						-		-
						-		-
						-		-
						-		-
						-		-
						-		-
						-		-
						-		-
						-		-
						-		-
<b>Change Order Totals</b>		\$ -	\$ -	\$ -	\$ -	\$ -		\$ -

<b>Original Contract and Change Orders</b>													
Project Totals	\$	5,177,000.00	\$	785,608.32	\$	152,509.58	\$	280,970.60	\$	1,219,088.50	24%	\$	3,957,911.50

**Progress Estimate - Unit Price Work**

**Contractor's Application for Payment**

<b>Owner:</b>	Okeechobee Utility Authority	<b>Owner's Project No.:</b>	
<b>Engineer:</b>	Sumner Engineering & Consulting, Inc.	<b>Engineer's Project No.:</b>	19-04.E
<b>Contractor:</b>	Hinterland Group, Inc.	<b>Contractor's Project No.:</b>	22-0234-00
<b>Project:</b>	Southwest Wastewater Service Area - Project 2		
<b>Contract:</b>	235-006.03		

**Application No.:** 6      **Application Period:** From 10/01/23 to 11/03/23      **Application Date:** 11/10/23

A Bid Item No.	B Description	C Contract Information				F Value of Bid Item (C X E) (\$)		G Work Completed Estimated Quantity Incorporated in the Work		H Value of Work Completed to Date (E X G) (\$)	I Materials Currently Stored (not in G) (\$)	J Work Completed and Materials Stored to Date (H + I) (\$)	K % of Value of Item (J / F) (%)	L Balance to Finish (F - J) (\$)
		C Item Quantity	D Units	E Unit Price (\$)	F Value of Bid Item (\$)	G Estimated Quantity Incorporated in the Work	H Value of Work Completed to Date (\$)							
<b>Original Contract</b>														
<b>Sanitary System</b>														
7a	Furnish and install SDR 21 PVC Vacuum main, Complete - 4 inch	28500.00	LF	\$ 55.00	1,567,500.00	19,711.00	1,084,105.00	33,337.92	1,117,442.92	71%	450,057.08			
7b	Furnish and install SDR 21 PVC Vacuum main, Complete - 6 inch	6100.00	LF	\$ 65.00	396,500.00	3,112.00	202,280.00	33,825.66	236,105.66	60%	160,394.34			
7c	Furnish and install SDR 21 PVC Vacuum main, Complete - 8 inch	2200.00	LF	\$ 80.00	176,000.00	1,341.00	107,280.00	10,368.12	117,648.12	67%	58,351.88			
7d	Furnish and install SDR 21 PVC Vacuum main, Complete - 10 inch	2900.00	LF	\$ 98.00	284,200.00	2,621.00	256,858.00	-	256,858.00	90%	27,342.00			
8a	Furnish and install Resilient Wedge Gate Division Valves, complete - 4-inch	45.00	EA	\$ 2,800.00	126,000.00	25.00	70,000.00	19,550.54	89,550.54	71%	36,449.46			
8b	Furnish and install Resilient Wedge Gate Division Valves, complete - 6-inch	12.00	EA	\$ 3,600.00	43,200.00	8.00	28,800.00	999.03	29,799.03	69%	13,400.97			
8c	Furnish and install Resilient Wedge Gate Division Valves, complete - 8-inch	2.00	EA	\$ 3,800.00	7,600.00	1.00	3,800.00	602.44	4,402.44	58%	3,197.56			
8d	Furnish and install Resilient Wedge Gate Division Valves, complete - 10-inch	3.00	EA	\$ 4,600.00	13,800.00	2.00	9,200.00	451.81	9,651.81	70%	4,148.19			
9a	Furnish and install vacuum collection pit assemblies, complete - Type "A" Adjacent to main	70	EA	\$ 12,500.00	875,000.00	3.00	37,500.00	489,337.50	526,837.50	60%	348,162.50			
9b	Furnish and install vacuum collection pit assemblies, complete - Type "A" Across from main	47	EA	\$ 14,200.00	667,400.00	1.00	14,200.00		14,200.00	2%	653,200.00			
9c	Furnish and install vacuum collection pit assemblies, complete - Type "B" Adjacent to main	62	EA	\$ 13,000.00	806,000.00	8.00	104,000.00		104,000.00	13%	702,000.00			
9d	Furnish and install vacuum collection pit assemblies, complete - Type "B" Across from main	18	EA	\$ 14,700.00	264,600.00		-		-	0%	264,600.00			
<b>Restoration</b>														
12a	Bahia Sod	38,830	LF	\$ 8.50	330,055.00	20,000.00	170,000.00		170,000.00	52%	160,055.00			
12b	Concrete Driveways	4,000	SY	\$ 95.00	380,000.00		-		-	0%	380,000.00			
12c	Asphalt Driveways	1,500	SY	\$ 65.00	97,500.00	250.00	16,250.00		16,250.00	17%	81,250.00			
12d	Gravel Driveways	1,400	SY	\$ 35.00	49,000.00		-		-	0%	49,000.00			
12e	Asphalt Millings Driveway	120	SY	\$ 50.00	6,000.00		-		-	0%	6,000.00			
12f	Brick Paver Driveway	50	SY	\$ 135.00	6,750.00		-		-	0%	6,750.00			
12g	Type 3: Asphaltic Concrete Pavement Patch	8,000	SY	\$ 85.00	680,000.00	695.00	59,075.00		59,075.00	9%	620,925.00			
					-		-		-		-			
<b>Original Contract Totals</b>					<b>\$ 6,777,105.00</b>		<b>\$ 2,163,348.00</b>	<b>\$ 588,473.02</b>	<b>\$ 2,751,821.02</b>	<b>41%</b>	<b>\$ 4,025,283.98</b>			
<b>Change Orders</b>														
					-		-		-		-			
					-		-		-		-			
					-		-		-		-			
					-		-		-		-			
					-		-		-		-			
					-		-		-		-			
					-		-		-		-			
					-		-		-		-			
					-		-		-		-			
					-		-		-		-			

**Progress Estimate - Unit Price Work**

**Contractor's Application for Payment**

<b>Owner:</b>	Okeechobee Utility Authority	<b>Owner's Project No.:</b>	
<b>Engineer:</b>	Sumner Engineering & Consulting, Inc.	<b>Engineer's Project No.:</b>	19-04.E
<b>Contractor:</b>	Hinterland Group, Inc.	<b>Contractor's Project No.:</b>	22-0234-00
<b>Project:</b>	Southwest Wastewater Service Area - Project 2		
<b>Contract:</b>	235-006.03		

Application No.: 6 Application Period: From 10/01/23 to 11/03/23 Application Date: 11/10/23

A	B	C	D	E	F	G	H	I	J	K	L				
Bid Item No.	Description	Contract Information				Work Completed		Materials Currently Stored (not in G) (\$)	Work Completed and Materials Stored to Date (H + I) (\$)	% of Value of Item (J / F) (%)	Balance to Finish (F - J) (\$)				
		Item Quantity	Units	Unit Price (\$)	Value of Bid Item (C X E) (\$)	Estimated Quantity Incorporated in the Work	Value of Work Completed to Date (E X G) (\$)								
					-		-		-		-				
					-		-		-		-				
					-		-		-		-				
					-		-		-		-				
					-		-		-		-				
					-		-		-		-				
					-		-		-		-				
					-		-		-		-				
					-		-		-		-				
					-		-		-		-				
					-		-		-		-				
					-		-		-		-				
					-		-		-		-				
					-		-		-		-				
					-		-		-		-				
<b>Change Order Totals</b>					\$	-	\$	-	\$	-	\$	-			
<b>Original Contract and Change Orders</b>															
<b>Project Totals</b>					\$	6,777,105.00	\$	2,163,348.00	\$	588,473.02	\$	2,751,821.02	41%	\$	4,025,283.98



**Stored Materials Summary**

**Contractor's Application for Payment**

<b>Owner:</b>	Okeechobee Utility Authority	<b>Owner's Project No.:</b>	
<b>Engineer:</b>	Sumner Engineering & Consulting, Inc.	<b>Engineer's Project No.:</b>	19-04.E
<b>Contractor:</b>	Hinterland Group, Inc.	<b>Contractor's Project No.:</b>	22-0234-00
<b>Project:</b>	Southwest Wastewater Service Area - Project 2		
<b>Contract:</b>	235-006.03		

Application No.: 6 Application Period: From 10/01/23 to 11/03/23 Application Date: 11/10/23

A Item No. (Lump Sum Tab) or Bid Item No. (Unit Price Tab)	B Supplier Invoice No.	C Submittal No. (with Specification Section No.)	D Description of Materials or Equipment Stored	E Storage Location	F Application No. When Materials Placed in Storage	Materials Stored			Incorporated in Work			M Materials Remaining in Storage (I-L) (\$)
						G Previous Amount Stored (\$)	H Amount Stored this Period (\$)	I Amount Stored to Date (G+H) (\$)	J Amount Previously Incorporated in the Work (\$)	K Amount Incorporated in the Work this Period (\$)	L Total Amount Incorporated in the Work (J+K) (\$)	
7a	129713335-0013, 129713335-0014, 131061850-001,		4" SDR 21 Pipe	P.S. 5	3	128,830.03		128,830.03	95,334.22	157.89	95,492.11	33,337.92
7b	129713335-001, 131061850-001, 132354976-001		6" SDR 21 Pipe	P.S. 5	1, 3	95,878.91		95,878.91	55,609.77	6,443.48	62,053.25	33,825.66
7c	129713335-001, 13235716-001		8" SDR 21 Pipe	P.S. 5	1, 3	45,100.50		45,100.50	34,732.38	-	34,732.38	10,368.12
7d	129713335-001, 129713335-0013		10" SDR 21 Pipe	P.S. 5	1, 3	96,100.91		96,100.91	96,100.91	-	96,100.91	-
8a	7732618-000-000		4" Mega Lugs for GV	P.S. 5	3	22,507.56		22,507.56	2,512.69	444.33	2,957.02	19,550.54
8b	7732618-000-000		6" Mega Lugs for GV	P.S. 5	3	2,179.70		2,179.70	1,089.85	90.82	1,180.67	999.03
8c	7732618-000-000		8" Mega Lugs for GV	P.S. 5	3	1,204.88		1,204.88	602.44	-	602.44	602.44
8d	7732618-000-000		10" Mega Lugs for GV	P.S. 5	3	1,355.44		1,355.44	903.63	-	903.63	451.81
9a	129713335-001, INV-0718		3" SDR 21 Pipe, Pit Assemblies	P.S. 5	1, 3	543,937.50		543,937.50	4,550.00	50,050.00	54,600.00	489,337.50
10d	INV104551		Single Girder Top Running Crane	J. Herbert Warehouse	5	14,868.00		14,868.00			-	14,868.00
11d	INV104550		Single Girder Top Running Crane	J. Herbert Warehouse	5	14,868.00		14,868.00			-	14,868.00
10i	Inv-0746		Pump Station Skid	Flovac Warehouse	5	237,500.00		237,500.00			-	237,500.00
10h	S2713287.001		SPDS for P.S. 4	Hinterland Warehouse	6	-	6,867.30	6,867.30	-	-	-	6,867.30
11h	S2713287.001		SPDS for P.S. 5	Hinterland Warehouse	6	-	6,867.30	6,867.30	-	-	-	6,867.30
								-			-	-
								-			-	-
								-			-	-
								-			-	-
								-			-	-
								-			-	-
								-			-	-
								-			-	-
								-			-	-
<b>Totals</b>						<b>\$ 1,204,331.43</b>	<b>\$ 13,734.60</b>	<b>\$ 1,218,066.03</b>	<b>\$ 196,101.66</b>	<b>\$ 57,186.52</b>	<b>\$ 348,622.41</b>	<b>\$ 869,443.62</b>



November 13, 2023

Okeechobee Utility Authority  
Attn: John F. Hayford, Executive Director  
100 SW 5<sup>th</sup> Avenue  
Okeechobee, FL 34974

**RE: Southwest Wastewater Service Area (SWSA) Project 2  
Vacuum Collection System and Pump Stations  
Monthly Status Report (October 1 – November 3, 2023)**

Mr. Hayford:

This letter is intended to summarize activities completed from October 1 – 31, 2023 on SWSA Project 2, including the vacuum collection system and vacuum stations.

**COLLECTION SYSTEM**

HINTERLAND GROUP (general contractor) continued installation of 4" and 6" sewer pipe, vacuum pit assemblies (VPAs) and service connections. Work performed in this period includes:

- Well point installed and asphalt cut for pipe construction along SW 16<sup>th</sup> St. between SW 23<sup>rd</sup> Terr. and SW 19<sup>th</sup> Terr.
- Installing 6" pipe along SW 16<sup>th</sup> St. between sta. 57+75 and 65+70. This work included connections to previously installed 4" pipe along SW 22<sup>nd</sup> and 23<sup>rd</sup> Terraces.
- Began roadway and driveway asphalt reconstruction in The Oak Park neighborhood.
- Installing 11 VPAs on SW 17<sup>th</sup> St. between SW 32<sup>nd</sup> Ave. and SW 37<sup>th</sup> Ave.
- Continue installing sod along roadways behind pipe crews.

**VACUUM STATION 4:**

- Well point pumping has continued.
- Basement floor slab was poured.
- Basement walls were formed, rebar placed, electrical conduit placed and walls poured.

Construction photos are included in Attachment A. If you have any questions, please do not hesitate to contact us.

Sincerely,  
**Sumner Engineering & Consulting, Inc.**

Jeffrey M. Sumner, PE  
President

# ATTACHMENT A

## SITE CONSTRUCTION PHOTOS COLLECTION SYSTEM and VPS #4







**OKEECHOBEE UTILITY AUTHORITY**

AGENDA ITEM NO. 9

NOVEMBER 21, 2023

**CONSENT AGENDA**

**INVOICE FROM LEWIS LONGMAN WALKER**

Please see attached invoice from Lewis Longman Walker.

**Staff recommends approval of the invoice from Lewis Longman Walker in the amounts of \$15,362.50.**



**LLW**

**LEWIS  
LONGMAN  
WALKER**

*360 South Rosemary Avenue  
Suite 1100  
West Palm Beach, FL 33401  
Tel 561-640-0820  
Fax 561-640-8202  
Tax ID No. 65-0500793*

Okeechobee Utility Authority  
100 SW 5th Avenue  
Okeechobee, FL 34974

November 3, 2023  
**Invoice No. WGC-155147**

CLIENT: 0504 - Okeechobee Utility Authority  
Re: 008 USDA Loan

<b>Date</b>		<b>Services</b>	<b>Hours</b>
10/02/23	WGC	Work on list of closing documents.	1.20
10/03/23	WGC	Work session regarding closing documents.	1.00
10/04/23	WGC	Correspondence with Bank Counsel; work session regarding closing document and logistics.	3.00
10/05/23	WGC	Correspondence with P. Dame and L. Hamilton; work on drafts of closing documents and IRS Form 8038-G.	3.50
10/06/23	WGC	Prepare drafts of closing documents.	4.50
10/09/23	WGC	Work session regarding preparation of closing documents; circulate drafts to financing working group.	4.20
10/10/23	WGC	Review comments on closing documents; make revisions and circulate revised documents; correspondence regarding requisition information; revise Issuer's Counsel Opinion; prepare IRS Form 8038-G.	5.20
10/11/23	WGC	Prepare complete set of closing documents and circulate same; telephone conferences and correspondence with financing working group; telephone conference with J. Hayford and L. Hamilton regarding substitute for Chairman.	5.00

Client Ref: 0504 - 008  
**Invoice No. WGC-155147**

November 3, 2023  
**Page 2**

<b>Date</b>	<b>Services</b>	<b>Hours</b>
10/12/23	WGC Work session regarding closing items; confirm receipt of required documents; telephone conferences with L. Hamilton and J. Trefelner; begin assembling transcript and information for Division of Bond Finance.	3.00
10/13/23	WGC Work session regarding post-closing items; prepare Bond Finance form; telephone conference with Division of Bond Finance regarding submittal glitch.	2.50
10/18/23	WGC Review information regarding filing of IRS Form 8038-G.	0.40
10/26/23	WGC Finalize Bond Finance Form and submit same to Florida Division of Bond Finance.	1.00
10/27/23	WGC Submit Form 8038-G to Internal Revenue Service; forward copy of Bond Finance Form to Executive Director Hayford and L. Hamilton.	1.00

**Summary of Services**

	<b>Rate</b>	<b>Hours</b>	<b>Amount</b>
WGC Capko, William G.	475.00	35.50	16,862.50
<b>Total for Services</b>		<b>35.50</b>	<b>\$16,862.50</b>
<b>Sub Total</b>			<b>\$16,862.50</b>
	Courtesy Discount		-1,500.00
	<b>Total for Services and Expenses</b>		<b>\$15,362.50</b>
	Previous Balance		3,467.50
	Payments Since Last Invoice		-3,467.50
	<b>Amount Due</b>		<b>\$15,362.50</b>



Invoice No. WGC-155147  
Invoice Date: November 3, 2023  
Client Code: 0504  
Client Name: Okeechobee Utility Authority  
Matter Code: 008  
Matter Name: USDA Loan

	<u>\$16,862.50</u>
Courtesy Discount	-1,500.00
<b>Total for Services and Expenses</b>	<u><b>\$15,362.50</b></u>
Previous Balance	3,467.50
Payments Since Last Invoice	-3,467.50
<b>Amount Due</b>	<u><b>\$15,362.50</b></u>

Amount enclosed: \_\_\_\_\_

Please remit checks to:

Lewis, Longman & Walker, P.A.  
PO Box 628742  
Orlando, FL 32862-8742

For your convenience, we accept credit card and e-check payments online at:

<http://www.llw-law.com/template/payment/>

For billing questions, please contact our Billing Department at: (561) 640-0820.

**OKEECHOBEE UTILITY AUTHORITY**

AGENDA ITEM NO. 10

NOVEMBER 21, 2023

**CONSENT AGENDA**

**INVOICE FROM HINTERLAND GROUP, INC. – PINE RIDGE PARK UTILITY  
IMPROVEMENTS**

Please find attached invoice in the amounts of \$427,149.64 submitted by Hinterland Group, Inc. Staff is aware of the work currently being done by Hinterland Group, Inc. and is in agreement with this request.

Invoice Date	Pay Request No.	Date Paid	Amt. Requested	Amount Paid	Remaining Balance
					\$5,143,000.00
Jul-22	Change Order #1		-\$712,125.05		\$4,430,874.95
Oct-22	1	Oct-22		\$110,913.06	\$4,319,961.89
Dec-22	2	Dec-22		\$478,757.06	\$3,841,204.83
Jan-23	3	Jan-23		\$280,563.22	\$3,560,641.61
Feb-23	4	Feb-23		\$231,874.10	\$3,328,767.51
Mar-23	5	Mar-23		\$330,737.75	\$2,998,029.76
Mar-23	6	Mar-23		\$403,728.72	\$2,594,301.04
Apr-23	7	Apr-23		\$323,735.44	\$2,270,565.60
Jun-23	8	Jun-23		\$71,522.68	\$2,199,042.92
Jun-23	Change Order #2		\$818,942.62		\$3,017,985.54
Aug-23	Change Order #3		-\$150,274.26		\$2,867,710.28
Aug-23	9	Aug-23		\$175,633.19	\$2,692,077.09
Aug-23	10	Aug-23		\$52,984.35	\$2,639,092.74
Oct-23	11	Oct-23		\$244,524.16	\$2,394,568.58
Nov-23	12		\$427,149.64		\$1,967,418.94

**Staff recommends approval of these invoice in the amounts of \$427,149.64 to Hinterland Group, Inc.**



November 14, 2023  
235-006.03

(Sent via email to [jhayford@ouafl.com](mailto:jhayford@ouafl.com))

Mr. John Hayford, P.E.  
Okeechobee Utility Authority  
100 SW 5th Avenue  
Okeechobee, FL 34974-4221

Dear Mr. Hayford:

Reference: Application and Certificate for Payment No. 12  
Pine Ridge Park Utility System Improvements

Enclosed is revised Payment Application and Certificate No. 12 for the above referenced project from Hinterland Group, Inc. **We recommend funding the requested hard cost amount of \$427,149.64 as payment for work completed from October 9, 2023, through November 09, 2023.** The work for which payment is being requested includes:

1. Partial Payment of 1% of Line Item 6- NPDES General Construction Permit Compliance.
2. Partial Payment of 5% of Line Item 10C- Building Shell.
3. Partial Payment of 10% of Line Item 10G- Electrical.
4. Partial Payment of 7% of Line Item 10Q- Labor and Supervision for installation and general site work.
5. Partial Payment of Change Order #02 addition of all sanitary sewer connections from R/W to Customer Tie-In. A total of 09 connections were made during this pay period.
6. Partial Payment of Change Order #02 addition of all water services connections from R/W to Customer Tie-In. A total of 81 connections were made during this pay period.
7. Payment for Stored Materials per Flovac payment terms for release for production and prior to shipment. Proof of storage is being provided with this pay request.

Please review the enclosed documents and if they meet your approval, please forward the Payment Application and Certificate documents to your Board for approval. Following Board approval, provide notice and/or copy of the enclosed Payment Application and Certificate to Hinterland Group with their payment.

If you have any questions or require additional information pertaining to the payment recommendation or the project status in general, please do not hesitate to contact me.

Sincerely,

A handwritten signature in blue ink that reads "Douglas K. Hamann". The signature is fluid and cursive, with a long horizontal stroke at the end.

Douglas K. Hamann, P.E.

Encl.

V:\Projects\CSFL122\Documents\Okeechobee\235-006.03 Pine Ridge Park Utility Improvements - SDC\Pay Requests\Pay App #12\Pay App #12.docx

4700 Riverside Drive, Suite 110, Coral Springs, FL 33067

T 954.510.4700 • F 954.755.2741 • [www.chacompanies.com](http://www.chacompanies.com)

**PAYMENT APPLICATION AND CERTIFICATE  
SIGNATURE PAGE**

**APPLICATION NUMBER 12**

<b>DATE</b>	<u>November 14, 2023</u>	<b>PROJECT NUMBER</b>	<u>235-006.03</u>
<b>PERIOD FROM</b>	<u>October 9, 2023</u>	<b>TO</b>	<u>November 9, 2023</u>
<b>PROJECT NAME</b>	<u>Pine Ridge Park Utility Improvements</u>		
<b>CONTRACTOR</b>	<u>Hinterland Group, Inc.</u>		

The Contractor is due the payment in the amount shown on the succeeding pages as payment for work completed in accordance with the provisions of the contract.

CHA Consulting, Inc. <u><i>Douglas Hammon</i></u>	Date _____
Owner _____	Date _____
_____	Date _____

**ACKNOWLEDGMENT OF PAYMENT**

We have received payment in the amount indicated on the Application and Certificate.

Contractor Hinterland Group, Inc.

Address 2051 W Blue Heron Blvd, Riviera Beach, FL 33404

By Mr. Chase Rogers

Title: Project Manager

**PLEASE SIGN AND RETURN ONE COPY OF THIS ACKNOWLEDGMENT TO THE ENGINEER.**

_____ Signature	Date _____
--------------------	------------

**PAYMENT APPLICATION AND CERTIFICATE**

Date: \_\_\_\_\_ Project No: \_\_\_\_\_

Application No: \_\_\_\_\_ Period From \_\_\_\_\_ To \_\_\_\_\_

Project: \_\_\_\_\_

To Owner: \_\_\_\_\_

From Contractor: \_\_\_\_\_

Thru Engineer: \_\_\_\_\_

- 1. Original Contract Sum. . . . . \$ \_\_\_\_\_
- 2. Approved Contract Modifications. . . . . \$ \_\_\_\_\_
- 3. Contract Modifications Approved This Period  
(List Contract Modification Numbers \_\_\_\_\_  
And attach copies of Contract Modifications). . . . . \$ \_\_\_\_\_
- 4. Revised Contract Amount (Sum of Lines 1 & 2). . . . . \$ \_\_\_\_\_
- 5. Total Value of Work completed to Date. . . . . \$ \_\_\_\_\_
- 6. Less Amount Retained ( \_\_\_\_\_ %). . . . . \$ \_\_\_\_\_
- 7. Subtotal (Line 5 - Line 6). . . . . \$ \_\_\_\_\_
- 8. Less Previous Certificates for Payment. . . . . \$ \_\_\_\_\_  
(Line 7 from previous application)
- 9. Current Payment Due (Line 7 - Line 8). . . . . \$ \_\_\_\_\_
- 10. Balance to Finish Plus Retainage (Line 4 - Line 7). . . . . \$ \_\_\_\_\_
- 11. Percent Project Complete ( \_\_\_\_\_ %)

CONTRACTOR'S CERTIFICATION

The undersigned Contractor certifies:

- 1. The Work covered by this Application for Payment has been completed in accordance with the Contract Documents.
- 2. All previous progress payments received from the OWNER on account of Work done under the Contract referred to above have been applied to discharge in full all obligations of the CONTRACTOR incurred in connection with Work covered by prior Applications for Payment numbered 9 thru <sup>5/31/2023</sup> inclusive.
- 3. Title to all materials and equipment incorporated in said work or otherwise listed in or covered by this Application for Payment will pass to the OWNER at time of payment free and clear of all liens, claims, security interests and encumbrances (except such as covered by bond acceptable to the OWNER).

*Josh Ramirez*

Contractor

11/14/2023

Date

Payment of the amount in  
Line 9 is recommended.

Project Representative

Date

**APPLICATION AND CERTIFICATION FOR PAYMENT**

AIA DOCUMENT G702

TO OWNER: **OKEECHOBEE UTILITY AUTHORITY**

**PROJECT: PINE RIDGE PARK UTILITY IMPROVEMENTS**

APPLICATION NO: **12**

APPLICATION DATE: **November 13, 2023**

PERIOD FROM: **October 9, 2023**

PERIOD TO: **November 9, 2023**

REVISION:

CONTRACT NO.: **235-006.03**

CONTRACTOR NO.: **22-0039-00**

FROM CONTRACTOR:

**Hinterland Group, Inc.  
2051 W Blue Heron Blvd.  
Riviera Beach, FL 33404**

**CONTRACTOR'S APPLICATION FOR PAYMENT**

Application is made for payment, as shown below, in connection with the Contract.

Continuation Sheet, AIA Document G703, is attached.

1. ORIGINAL CONTRACT SUM	\$	<u>5,143,000.00</u>
2. Net change by Change Orders	\$	<u>(43,456.66)</u>
3. CONTRACT SUM TO DATE (Line 1 + 2)	\$	<u>5,099,543.34</u>
4. TOTAL COMPLETED & STORED TO DATE:	\$	<u>3,296,972.00</u>
5. RETAINAGE:		
a. <u>5</u> % of Completed Work	\$	<u>144,456.48</u>
(Column D + E on G703)		
b. <u>5</u> % of Stored Material	\$	<u>20,392.12</u>
(Column F on G703)		
Total Retainage (Lines 5a + 5b or		
Total in Column I of G703)		
	\$	<u>164,848.60</u>
6. TOTAL EARNED LESS RETAINAGE	\$	<u>\$3,132,123.40</u>
(Line 4 Less Line 5 Total)		
7. LESS PREVIOUS CERTIFICATES FOR		
PAYMENT (Line 6 from prior Certificate)	\$	<u>2,704,973.76</u>
8. CURRENT PAYMENT DUE	\$	<u>427,149.64</u>
9. BALANCE TO FINISH, INCLUDING RETAINAGE	\$	<u>1,967,419.94</u>
(Line 3 less Line 6)		

CHANGE ORDER SUMMARY	ADDITIONS	DEDUCTIONS
Total changes approved in previous months by Owner	\$818,942.65	\$862,399.31
Total approved this Month	\$0.00	0.00
<b>TOTALS</b>	<b>\$818,942.65</b>	<b>\$862,399.31</b>
<b>NET CHANGES by Change Order</b>	<b>(\$43,456.66)</b>	

The undersigned Contractor certifies that to the best of the Contractor's knowledge, information and belief, the Work covered by this Application for Payment has been completed in accordance with the Contract Documents, that all amounts have been paid by the Contractor for Work for which previous Certificates for Payment were issued and payments received from the Owner, and that current payment shown herein is now due.

CONTRACTOR: HINTERLAND GROUP, INC.

By:  Date: 11/13/2023  
Josh Ramirez, Project Manager

State of: Florida County of: Palm Beach

Subscribed and sworn to before me this \_\_\_\_\_ 2022

Notary Public: 

My Commission expires: \_\_\_\_\_



**ENGINEER'S CERTIFICATE FOR PAYMENT**

In accordance with the Contract Documents, based on on-site observations and the data comprising the application, the Engineer certifies to the Owner, that to the best of the Engineer's knowledge, information and belief, the Work has progressed as indicated, the quality of the Work is in accordance with the Contract Documents, and the Contractor is entitled to payment of the amount certified.

AMOUNT CERTIFIED . . . . \$ \_\_\_\_\_

Attach explanation if amount certified differs from the amount applied. Initial all figures on this Application and on the Continuation Sheet that are changed to conform with the amount certified.

ENGINEER/ARCHITECT:

By:  Date: \_\_\_\_\_

This Certificate is not negotiable. The AMOUNT CERTIFIED is payable only to the Contractor named herein. Issuance, payment and acceptance of payment are without prejudice to any rights of the Owner or Contractor under this Contract.

**SCHEDULE OF VALUES**

AIA DOCUMENT G703

AIA Document G702, APPLICATION AND CERTIFICATION FOR PAYMENT, containing Contractor's signed certification is attached.

CONTRACT: 235-006.03  
PROJECT TITLE: PINE RIDGE PARK UTILITY IMPROVEMENTS

APPLICATION NO: 12  
APPLICATION DATE: 11/13/2023  
PERIOD TO: 11/9/2023  
PROJECT NO.: 235-006.03  
CONTRACT NO.: 22-0039-00

In tabulations below, amounts are stated to the nearest dollar.

Use Column I on Contracts where variable retainage for line items may apply.

A ITEM NO.	FDOT PAY ITEM NO.	B DESCRIPTION OF WORK ITEM	C QTY	D UNIT	E UNIT PRICE	F SCHEDULED VALUE TOTAL	G WORK COMPLETED FROM PREVIOUS APPL		H WORK COMPLETED THIS PERIOD		I QTY TO DATE	J MATERIALS PRESENTLY STORED (NOT IN GOR H)	K TOTAL COMPLETED AND STORED TO DATE (G+H+J)	L % (K ÷ F)	M BALANCE TO FINISH (F - K)	N TOTAL RETAINAGE  5.00%
							QTY	AMOUNT (G + H)	QTY	AMOUNT						
<b>GENERAL</b>																
1		Mobilization	1	LS	\$ 316,000.00	\$316,000.00	0.950	\$300,200.00		\$0.00	0.95	\$0.00	\$300,200.00	95%	\$15,800.00	\$15,010.00
2		Indemnification	1	LS	\$ 51,500.00	\$51,500.00	1.000	\$51,500.00		\$0.00	1	\$0.00	\$51,500.00	100%	\$0.00	\$2,575.00
3		As-Built Record Drawings	1	LS	\$ 34,200.00	\$34,200.00	0.850	\$29,070.00		\$0.00	0.85	\$0.00	\$29,070.00	85%	\$5,130.00	\$1,453.50
4		Maintenance of Traffic	1	LS	\$ 34,200.00	\$34,200.00	0.950	\$32,490.00		\$0.00	0.95	\$0.00	\$32,490.00	95%	\$1,710.00	\$1,624.50
5		Existing Utility Location/ Identification	1	LS	\$ 10,260.00	\$10,260.00	1.000	\$10,260.00		\$0.00	1	\$0.00	\$10,260.00	100%	\$0.00	\$513.00
6		NPDES General Construction Permit Compliance	1	LS	\$ 10,260.00	\$10,260.00	0.950	\$9,747.00	0.01	\$102.60	0.96	\$0.00	\$9,849.60	96%	\$410.40	\$492.48
<b>SANITARY SYSTEM</b>																
7a		Furnish and install SDR 21 PVC vacuum main, complete - 4 inch	8100.00	LF	\$46.46	\$376,326.00	8100.000	\$376,326.00		\$0.00	8100	\$0.00	\$376,326.00	100%	\$0.00	\$18,816.30
7b		Furnish and install SDR 21 PVC vacuum main, complete - 6 inch	1900.00	LF	\$57.35	\$108,965.00	1900.000	\$108,965.00		\$0.00	1900	\$0.00	\$108,965.00	100%	\$0.00	\$5,448.25
7c		Furnish and install SDR 21 PVC vacuum main, complete - 8 inch	600.00	LF	\$79.80	\$47,880.00	600.000	\$47,880.00		\$0.00	600	\$0.00	\$47,880.00	100%	\$0.00	\$2,394.00
8a		Furnish and install division valves and boxes, complete - 4-inch	12.00	EA	\$ 2,115.00	\$25,380.00	12.000	\$25,380.00		\$0.00	12	\$0.00	\$25,380.00	100%	\$0.00	\$1,269.00
8b		Furnish and install division valves and boxes, complete - 6-inch	5.00	EA	\$ 2,360.00	\$11,800.00	5.000	\$11,800.00		\$0.00	5	\$0.00	\$11,800.00	100%	\$0.00	\$590.00
8c		Furnish and install division valves and boxes, complete - 8-inch	1.00	EA	\$ 3,741.00	\$3,741.00	1.000	\$3,741.00		\$0.00	1	\$0.00	\$3,741.00	100%	\$0.00	\$187.05
9a		Furnish and install vacuum collection pit assemblies, complete - Type "A" Adjacent to main	34	EA	\$ 8,800.00	\$ 299,200.00	34	\$299,200.00		\$0.00	34	\$0.00	\$299,200.00	100%	\$0.00	\$14,960.00
9b		Furnish and install vacuum collection pit assemblies, complete - Type "A" Across from main	7	EA	\$ 9,575.00	\$ 67,025.00	7	\$67,025.00		\$0.00	7	\$0.00	\$67,025.00	100%	\$0.00	\$3,351.25
9c		Furnish and install vacuum collection pit assemblies, complete - Type "B" Adjacent to main	11	EA	\$ 10,035.00	\$ 110,385.00	11	\$110,385.00		\$0.00	11	\$0.00	\$110,385.00	100%	\$0.00	\$5,519.25
9d		Furnish and install vacuum collection pit assemblies, complete - Type "B" Across from main	3	EA	\$ 10,260.00	\$ 30,780.00	3	\$30,780.00		\$0.00	3	\$0.00	\$30,780.00	100%	\$0.00	\$1,539.00
<b>Furnish and install vacuum pump station with equipment, complete</b>																
10a		Mobilization	1	LS	\$ 50,140.00	\$50,140.00	1	\$50,140.00		\$0.00	1	\$0.00	\$50,140.00	100%	\$0.00	\$2,507.00
10b		Underground Building Section Excavation and Dewatering	1	LS	\$ 65,000.00	\$65,000.00	1	\$65,000.00		\$0.00	1	\$0.00	\$65,000.00	100%	\$0.00	\$3,250.00
10c		Building Shell	1	LS	\$ 340,000.00	\$340,000.00	0.35	\$119,000.00	0.05	\$17,000.00	0.4	\$0.00	\$136,000.00	40%	\$204,000.00	\$6,800.00
10d		Finish Roofing	1	LS	\$ 35,000.00	\$35,000.00		\$0.00		\$0.00	0	\$0.00	\$0.00	0%	\$35,000.00	\$0.00
10e		Gutters	1	LS	\$ 12,000.00	\$12,000.00		\$0.00		\$0.00	0	\$0.00	\$0.00	0%	\$12,000.00	\$0.00
10f		Overhead Crane	1	LS	\$ 40,000.00	\$40,000.00	0.375	\$15,000.00		\$0.00	0.375	\$0.00	\$15,000.00	38%	\$25,000.00	\$750.00
		Generator (Furnish Only)	1	LS	\$ 125,000.00	\$125,000.00		\$0.00		\$0.00	0	\$0.00	\$0.00	0%	\$125,000.00	\$0.00
10g		Electrical	1	LS	\$ 235,000.00	\$235,000.00	0.5	\$117,500.00	0.1	\$23,500.00	0.6	\$0.00	\$141,000.00	60%	\$94,000.00	\$7,050.00
10h		Flovac System (Furnish Only)	1	LS	\$ 481,000.00	\$481,000.00		\$0.00		\$0.00	0	\$337,500.00	\$337,500.00	70%	\$143,500.00	\$16,875.00
10i		Piping Material (Furnish Only)	1	LS	\$ 45,000.00	\$45,000.00		\$0.00		\$0.00	0	\$0.00	\$0.00	0%	\$45,000.00	\$0.00
10j		Stucco and Paint Finish	1	LS	\$ 55,000.00	\$55,000.00		\$0.00		\$0.00	0	\$0.00	\$0.00	0%	\$55,000.00	\$0.00
10k		HVAC	1	LS	\$ 35,000.00	\$35,000.00		\$0.00		\$0.00	0	\$0.00	\$0.00	0%	\$35,000.00	\$0.00
10l		Louvers and Metalwork	1	LS	\$ 45,000.00	\$45,000.00		\$0.00		\$0.00	0	\$0.00	\$0.00	0%	\$45,000.00	\$0.00
10m		Ordor Control	1	LS	\$ 15,000.00	\$15,000.00		\$0.00		\$0.00	0	\$0.00	\$0.00	0%	\$15,000.00	\$0.00
10n		General Plumbing	1	LS	\$ 12,000.00	\$12,000.00	0.5	\$6,000.00		\$0.00	0.5	\$2,263.87	\$8,263.87	69%	\$3,736.13	\$413.19
10o		Bathroom	1	LS	\$ 15,000.00	\$15,000.00		\$0.00		\$0.00	0	\$0.00	\$0.00	0%	\$15,000.00	\$0.00
10p		Doors	1	LS	\$ 25,000.00	\$25,000.00	0.35	\$8,750.00		\$0.00	0.35	\$0.00	\$8,750.00	35%	\$16,250.00	\$437.50
10q		Labor and Supervision for installation and General Site Work	1	LS	\$ 125,000.00	\$125,000.00	0.68	\$85,000.00	0.07	\$8,750.00	0.75	\$0.00	\$93,750.00	75%	\$31,250.00	\$4,687.50
<b>OUA Vacuum Building Breakdown Total</b>																
11		Abandon septic tanks, complete	111	EA	\$ 1,370.00	\$152,070.00		\$0.00		\$0.00	0	\$0.00	\$0.00	0%	\$152,070.00	\$0.00
12		Abandon manholes, complete	7	EA	\$ 1,940.00	\$13,580.00		\$0.00		\$0.00	0	\$0.00	\$0.00	0%	\$13,580.00	\$0.00
13		Furnish and Install Sanitary Service Connections (R/W to Customer Tie-In), complete	111	EA	\$ 3,085.00	\$342,435.00		\$0.00		\$0.00	0	\$0.00	\$0.00	0%	\$342,435.00	\$0.00
14		Grout and Abandon Sanitary Sewer Pipe, complete	450	LF	\$ 15.50	\$6,975.00		\$0.00		\$0.00	0	\$0.00	\$0.00	0%	\$6,975.00	\$0.00
<b>WATER SYSTEM</b>																
15a		Furnish and install C900 DR 18 PVC water main, complete - 6-inch	1,350	LF	\$ 37.40	\$50,490.00	1310	\$48,994.00		\$0.00	1310	\$0.00	\$48,994.00	97%	\$1,496.00	\$2,449.70
15b		Furnish and install C900 DR 18 PVC water main, complete - 8-inch	1,370	LF	\$ 50.10	\$68,637.00	1264	\$63,326.40		\$0.00	1264	\$0.00	\$63,326.40	92%	\$5,310.60	\$3,166.32
16a		Furnish and install SDR 11 HDPE water main, complete - 2-inch	3,460	LF	\$ 19.70	\$68,162.00	3460	\$68,162.00		\$0.00	3460	\$0.00	\$68,162.00	100%	\$0.00	\$3,408.10
17a		Furnish and install gate valves and boxes, complete 6"	12	EA	\$ 2,540.00	\$30,480.00	12	\$30,480.00		\$0.00	12	\$0.00	\$30,480.00	100%	\$0.00	\$1,524.00
17b		Furnish and install gate valves and boxes, complete 8"	5	EA	\$ 3,340.00	\$16,700.00	5	\$16,700.00		\$0.00	5	\$0.00	\$16,700.00	100%	\$0.00	\$835.00
18a		Furnish, install, and remove sample points, complete, inclusive of bacteriological testing, complete - On Main	13	EA	\$ 1,150.00	\$14,950.00	13	\$14,950.00		\$0.00	13	\$0.00	\$14,950.00	100%	\$0.00	\$747.50
18b		Furnish, install, and remove sample points, complete, inclusive of bacteriological testing, complete - On Fire Hydrant	4	EA	\$ 1,150.00	\$4,600.00	4	\$4,600.00		\$0.00	4	\$0.00	\$4,600.00	100%	\$0.00	\$230.00
19		Furnish and install fire hydrant assemblies, complete	5	EA	\$ 9,300.00	\$46,500.00	5	\$46,500.00		\$0.00	5	\$0.00	\$46,500.00	100%	\$0.00	\$2,325.00
20a		Furnish and install single water service with angle stop and meter box (adjacent), complete	4	EA	\$ 1,000.00	\$4,000.00	4	\$4,000.00		\$0.00	4	\$0.00	\$4,000.00	100%	\$0.00	\$200.00
20b		Furnish and install single water service with angle stop and meter box (opposite), complete	4	EA	\$ 1,800.00	\$7,200.00	4	\$7,200.00		\$0.00	4	\$0.00	\$7,200.00	100%	\$0.00	\$360.00
20c		Furnish and install double water service with two (2) angle stops and meter boxes (adjacent), complete	24	EA	\$ 1,600.00	\$38,400.00	24	\$38,400.00		\$0.00	24	\$0.00	\$38,400.00	100%	\$0.00	\$1,920.00
20d		Furnish and install double water service with two (2) angle stops and meter boxes (opposite), complete	24	EA	\$ 2,730.00	\$65,520.00	24	\$65,520.00		\$0.00	24	\$0.00	\$65,520.00	100%	\$0.00	\$3,276.00
21		Furnish and Install Water Service Connections (R/W to Customer Tie-In), complete	131	EA	\$ 1,460.00	\$191,260.00		\$0.00		\$0.00	0	\$0.00	\$0.00	0%	\$191,260.00	\$0.00

**SCHEDULE OF VALUES**

AIA DOCUMENT G703

AIA Document G702, APPLICATION AND CERTIFICATION FOR PAYMENT, containing Contractor's signed certification is attached.

CONTRACT: 235-006.03  
PROJECT TITLE: PINE RIDGE PARK UTILITY IMPROVEMENTS

APPLICATION NO: 12  
APPLICATION DATE: 11/13/2023  
PERIOD TO: 11/9/2023  
PROJECT NO.: 235-006.03  
CONTRACT NO.: 22-0039-00

In tabulations below, amounts are stated to the nearest dollar.

Use Column I on Contracts where variable retainage for line items may apply.

A ITEM NO.	B FDOT PAY ITEM NO.	C DESCRIPTION OF WORK ITEM	D QTY	E UNIT	F UNIT PRICE	G SCHEDULED VALUE TOTAL	H WORK COMPLETED FROM PREVIOUS APPL		I WORK COMPLETED THIS PERIOD		J MATERIALS PRESENTLY STORED (NOT IN G OR H)	K TOTAL COMPLETED AND STORED TO DATE (G+H-I)	L % (K ÷ F)	M BALANCE TO FINISH (F - K)	N TOTAL RETAINAGE 5.00%
							QTY	AMOUNT (G + H)	QTY	AMOUNT					
							QTY TO DATE								
22		Disconnect wells, complete	104	EA	\$ 185.00	\$19,240.00		\$0.00	\$0.00	0	\$0.00	\$0.00	0%	\$19,240.00	\$0.00
23		Furnish and install ductile iron compact fittings with reaction blocking or thrust restraints, complete	1.5	TN	\$ 18,200.00	\$27,300.00	1.4	\$25,480.00	\$0.00	1.4	\$0.00	\$25,480.00	93%	\$1,820.00	\$1,274.00
24		Grout and Abandon Water Main Pipe, complete	310	LF	\$ 15.50	\$4,805.00		\$0.00	\$0.00	0	\$0.00	\$0.00	0%	\$4,805.00	\$0.00
<b>RESTORATION</b>															
25		Furnish and place sod, complete	11,000	LF	\$ 2.85	\$31,350.00	11000	\$31,350.00	\$0.00	11000	\$0.00	\$31,350.00	100%	\$0.00	\$1,567.50
26		Asphaltic Driveways, complete	330	SY	\$ 57.00	\$18,810.00		\$0.00	\$0.00	0	\$0.00	\$0.00	0%	\$18,810.00	\$0.00
27		Concrete Driveways, complete	1,840	SY	\$ 74.10	\$136,344.00		\$0.00	\$0.00	0	\$0.00	\$0.00	0%	\$136,344.00	\$0.00
28		Gravel Driveways, complete	1,200	SY	\$ 22.80	\$27,360.00	800	\$18,240.00	\$0.00	800	\$0.00	\$18,240.00	67%	\$9,120.00	\$912.00
29		Asphalt Road Patch, complete	1,850	SY	\$ 25.30	\$46,805.00	1850	\$46,805.00	\$0.00	1850	\$0.00	\$46,805.00	100%	\$0.00	\$2,340.25
30		Headwall Replacement, complete	7	EA	\$ 855.00	\$5,985.00		\$0.00	\$0.00	0	\$0.00	\$0.00	0%	\$5,985.00	\$0.00
31		Pavement Markings/Restoration Allowance	1	LS	\$ 10,000.00	\$10,000.00		\$0.00	\$0.00	0	\$0.00	\$0.00	0%	\$10,000.00	\$0.00
32		Miscellaneous Work Allowance	1	LS	\$ 400,000.00	\$400,000.00	20.90%	\$83,600.55	\$0.00	0.209001375	\$0.00	\$83,600.55	21%	\$316,399.45	\$4,180.03
<b>Change Orders</b>															
CO#1 -1		Removal of all septic tank abandonments. This affects Bid Item No. 11	1.00	LS	-\$152,070.00	-\$152,070.00		\$0.00	\$0.00	0	\$0.00	\$0.00	0%	-\$152,070.00	\$0.00
CO#1 -2		Removal of all sanitary sewer connections form R/W to customer tie-in. This affects Bid Item No.13.	1.00	LS	-\$342,435.00	-\$342,435.00		\$0.00	\$0.00	0	\$0.00	\$0.00	0%	-\$342,435.00	\$0.00
CO#1 -3		Removal of all water service connections form R/W to customer tie-in. This affects Bid Item No. 21	1.00	LS	-\$191,260.00	-\$191,260.00		\$0.00	\$0.00	0	\$0.00	\$0.00	0%	-\$191,260.00	\$0.00
CO#1 -4		Removal of all well disconnections. This affects Bid Item No. 22.	1.00	LS	-\$19,240.00	-\$19,240.00		\$0.00	\$0.00	0	\$0.00	\$0.00	0%	-\$19,240.00	\$0.00
CO#1 -5		Reduction of Bid Items No. 1 through 6 as a result of work being removed in items 1 through 5 above.	1.00	LS	-\$7,120.05	-\$7,120.05		\$0.00	\$0.00	0	\$0.00	\$0.00	0%	-\$7,120.05	\$0.00
CO#2 -1		Addition of Bid Items No. 1 through 6 as a result of work being added in items 2 through 5 below.	1.00	LS	\$7,120.05	\$7,120.05	1	\$7,120.05	\$0.00	1	\$0.00	\$7,120.05	100%	\$0.00	\$356.00
CO#2 -2		Addition of all septic tank abandonments. This affects Bid Item No. 11	111.00	EA	\$1,370.00	\$152,070.00		\$0.00	\$0.00	0	\$0.00	\$0.00	0%	\$152,070.00	\$0.00
CO#2 -3		Addition of all sanitary sewer connections form R/W to customer tie-in. This affects Bid Item No.13.	111.00	EA	\$3,702.00	\$410,922.00	3	\$11,106.00	\$33,318.00	12	\$68,078.53	\$112,502.53	27%	\$298,419.47	\$5,625.13
CO#2 -4		Addition of all water service connections form R/W to customer tie-in. This affects Bid Item No. 21	131.00	EA	\$1,752.60	\$229,590.60	29	\$50,825.40	\$141,960.60	110	\$0.00	\$192,786.00	84%	\$36,804.60	\$9,639.30
CO#2 -5		Addition of all well disconnections. This affects Bid Item No. 22.	104.00	EA	\$185.00	\$19,240.00		\$0.00	\$0.00	0	\$0.00	\$0.00	0%	\$19,240.00	\$0.00
CO#3		Deductive Change Order for Generator	1.00	LS	-\$150,274.26	-\$150,274.26		\$0.00	\$0.00						
<b>TOTAL</b>						<b>\$5,099,543.34</b>		<b>\$2,664,498.40</b>	<b>\$224,631.20</b>		<b>\$407,842.40</b>	<b>\$3,296,972.00</b>		<b>\$1,952,845.60</b>	<b>\$164,848.60</b>
<b>BID ALTERNATE ITEMS</b>															
1A		Furnish and install 2-inch HDPE water main via directional drill, inclusive of all fittings, transition pieces, appurtenances; set up, mobilization, and demobilization	3,460	LF	\$ 17.20	\$59,512.00		\$0.00	\$0.00	0	\$0.00	\$0.00	0%	\$59,512.00	\$0.00
2A-a		Furnish and install single water service with angle stop and meter box (adjacent), complete	4	EA	\$ 1,120.00	\$4,480.00		\$0.00	\$0.00	0	\$0.00	\$0.00	0%	\$4,480.00	\$0.00
2A-b		Furnish and install single water service with angle stop and meter box (opposite), complete	4	EA	\$ 1,915.00	\$7,660.00		\$0.00	\$0.00	0	\$0.00	\$0.00	0%	\$7,660.00	\$0.00
2A-c		Furnish and install double water service with two (2) angle stops and meter boxes (adjacent), complete	24	EA	\$ 1,710.00	\$41,040.00		\$0.00	\$0.00	0	\$0.00	\$0.00	0%	\$41,040.00	\$0.00
2A-d		Furnish and install double water service with two (2) angle stops and meter boxes (opposite), complete	24	EA	\$ 2,845.00	\$68,280.00		\$0.00	\$0.00	0	\$0.00	\$0.00	0%	\$68,280.00	\$0.00
3A		Deductive Alternate for providing an Alternate Generator System/ Manufacturer meeting the requirements of specifications Section 16204T. (Value accounted for under G702)	1	LS	\$ 150,274.26	\$150,274.26		\$0.00	\$0.00	0	\$0.00	\$0.00	0%	\$150,274.26	\$0.00



# Stored Materials Summary

AIA Document G702, APPLICATION AND CERTIFICATION FOR PAYMENT, containing Contractor's signed certification is attached.  
 In tabulations below, amounts are stated to the nearest dollar.  
 Use Column I on Contracts where variable retainage for line items may apply.

APPLICATION NO: 12  
 APPLICATION DATE: 11/13/2023  
 PERIOD TO: 11/9/2023  
 PROJECT NO.: 235-006.03  
 CONTRACT NO.: 22-0039-00

A		B	C	D	E
Item No.	Supplier Invoice No.	Description of Materials or Equipment Stored	Amount Previously Stored (\$)	Amount Stored this Month (\$)	Amount Completed and Stored to Date (C + D)
7b	68004	6" PVC Pipe SDR-21	\$ -	\$ -	\$ -
7c	68004	8" PVC Pipe SDR-21	\$ -	\$ -	\$ -
9a	619	28 Type A valve pits	\$ -	\$ -	\$ -
9b	630	28 Type A valve pits	\$ -	\$ -	\$ -
10h	619, Inv-0739	50% Upon receipt of approved shop drawings at release for production and Deliver of Materials	\$ 112,500.00	\$ 225,000.00	\$ 337,500.00
9c	7730669	6x4" PVC IPS Vaccum WYE, 4" PVC Vacuum 45 degree bend, 4" PVC IPS Vacuum WYE.	\$ -	\$ -	\$ -
CO#2 -Line Items 3 and 4	5995552	Project Material Deposit	\$ 68,078.53	\$ -	\$ 68,078.53
10n	8046417	304 S.S. Pipe for Odor Control	\$ 2,263.87	\$ -	\$ 2,263.87
					\$ -
		<b>Totals</b>	\$ 182,842.40	\$ 225,000.00	\$ 407,842.40

## INVOICE

Hinterland Group Inc  
 2051 W Blue Heron Blvd  
 RIVIERA BEACH FL 33404  
 USA

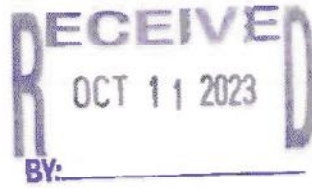

**Invoice Date**  
 Oct 11, 2023

15 Utility Dr, Suite A  
 Palm Coast, FL 32137

**Invoice Number**  
 INV-0739

(386) 319-0350  
 www.flovac.com

**Reference**  
Pine Ridge 50% Upon Delivery  
 of Materials - Station

Item	Description	Quantity	Unit Price	Tax	Amount USD
	TERMS: With acceptable credit at the time of order, the payment terms are as follows:				
	<ul style="list-style-type: none"> <li>• 25% Upon receipt of approved shop drawings at release for production</li> <li>• 50% Upon delivery of materials</li> <li>• 25% At Project Commissioning (not to exceed 180 Days from shipment)</li> </ul>				
	Per Agreement				
	50% Upon delivery of materials Vacuum Pump Station	1.00	225,000.00	Tax Exempt	225,000.00
				Subtotal	225,000.00
				TOTAL TAX	0.00
				<b>TOTAL USD</b>	<b>225,000.00</b>

006

JOB Number:	22 00 39 00
COST Code:	02 22 90
Category:	S (1, 2, or 3 Letters)
OR GL Code:	_____

**Due Date: Nov 10, 2023**  
 Send Wires to:  
 FLOVAC, INC  
 BANK OF AMERICA  
 BA-153-01-01, 2 Old Kings Rd., North  
 Palm Coast, FL 32137  
 ACCOUNT#: 898069671530  
 ABA/ ROUTING#: 026009593



**\*WARNING! WIRE FRAUD ADVISORY:** Wire fraud and email hacking/phishing attacks are on the increase! ... Instead, call your account rep, using the previously known contact information and NOT information provided in the email, to verify the information prior to sending funds.\*

Send Checks to:  
 15 Utility Dr, Suite A  
 Palm Coast, FL 32137

# Hinterland Group Inc

Invoice Approval Page

Vendor: FloVac - Flovac Inc

InvoiceNo: INV-0739

Invoice Date: 10-11-2023 10:46:18 AM

Amount: 225000

Comment: 22-0039-00

**RECEIVED**  
10-12-2023 10:45:54 AM

BETH MARIKOS

**ENTERED**  
10-12-2023 11:26:13 AM

BETH MARIKOS

**REJECTED**  
10-16-2023 02:52:24 PM

JOSH RAMIREZ

**ENTERED**  
11-07-2023 01:11:54 PM

BETH MARIKOS

**APPROVED**  
11-08-2023 09:56:31 AM

JOSH RAMIREZ

**REVIEWED**  
11-09-2023 07:49:53 AM

JERRY WICHERT

**POSTED**  
11-09-2023 07:50:10 AM

JERRY WICHERT



# Okeechobee Utility Authority

## Pine Ridge Park Utility System Improvements

**BID ITEM 9) a, b, c & d** Furnish vacuum collection pits complete. Qty 56. 42 Type A \$4250ea.  
14 Type B \$4550ea

- FLOVAC Complete Valve Pit Package (Type A and B) includes:
- FLOVAC Complete 3 Vacuum Valve and Controls
- FLOVAC Collector Pit
- FLOVAC Unidirectional terminal
- Gate Valve
- No-Hub
- Controller Breather
- Sensor Pipe, Suction Pipe and all related Pipework, Fittings and Ornaments

Note: FLOVAC's Complete Valve Pit Package is delivered to the jobsite fully assembled and factory tested.

### PORTABLE VACUUM TEST TRAILER (No Charge, Return at end of project)

**BID ITEM 10)** Furnish vacuum pump station equipment, complete. Qty 1. Total \$450,000

- 2.12 FLOVAC Vacuum pump skid and related controls
- 2.13 FLOVAC Collection tank and sewer pump skid
- 2.14 FLOVAC Maint control panel
- 2.23 FLOVAC Vacuum test bench, assembled
- Moisture separators
- Instrumentation and control
- All equipment protected before delivery
- Testing per section 235-006.01 (3.04-3.06)

System Commissioning with the Owner (one-week commissioning)  
Storage of Equipment and delivery to site at request of contractor/owner



WARRANTY

Flovac Americas warrants there 3" valves and controls for a period of 10 years. The valve pits, vacuum station equipment and associated equipment is warranted for a period of 7 years and will conform as outlined in the

Flexible shipment and storage available. Check with you rep

SUMMARY

The intent of this supply proposal is to provide the contractor and OUA with everything needed to ensure the best possible project experience and contract success. Flovac is aware of many advantages of our product

As a point of interest, The Flovac team has specialized in intentional sewerage schemes and has been involved in

We at FLOVAC are incredibly pleased to have the opportunity to assist in the pursuit of continuously improving the operation and reliability of vacuum sewerage collection system. We are confident that Flovac supplied

c.c. John Radinoff, CEO



Director of Operations















NATIONAL
SERIAL
YEAR B
VESSEL
INTER





30 TON







## Monthly Project Status Update – October 2023

Project Name: Pine Ridge Park Utility Improvements

Project No.: 235-006.03

Client: Okeechobee Utility Authority

Client’s Project Manager: John Hayford, P.E.

Engineer’s Project Manager: Douglas Hammann, P.E.

Contractor: Hinterland Group, Inc.

Contractor’s Project Manager: Joshua Ramirez

### **Work completed this month:**

- Contractor shop drawing review.
- Contractor continues their MOT setup.
- CHA Consulting, Inc. held an onsite meeting to conduct walkthrough of project to generate final punch list.
- CHA Consulting, Inc. conducted an onsite visit of Vacuum Pump Station construction with Hinterland Group, Inc.
- CHA Consulting, Inc. coordinated with the Okeechobee County Public Works Department for project walk through and inspection of right-of-way.
- Contractor continued work on Vacuum Pump Station site to include electrical and general plumbing for the above-grade portion of the project.
- Contractor scheduled Building Inspections with the County Building Department.
- Contractor continued the customer connection for the project for water & sewer connections.

### **Project Schedule Status:**

Notice to Proceed (NTP)	June 21, 2022
Original Contract Date of Substantial Completion (425 days)	August 19, 2023
Original Contract Date of Final Completion (455 days)	September 18, 2023
Revised Contract Date of Substantial Completion (606 days)	February 16, 2024
Revised Contract Date of Final Completion (636 days)	March 17, 2024

Days Since NTP	507
Days Remaining until Substantial Completion	98
Percent of Days Remaining	16%

### **Project Financial Status:**

#### Contractor’s Payment Applications

Pay App. No.	Payment Amount	Contract Amount	Remaining	Percent Complete
12	\$232,853.74	\$5,099,543.34 <sup>1</sup>	\$2,161,715.88	61%

<sup>1</sup> Per Change Order No. 3









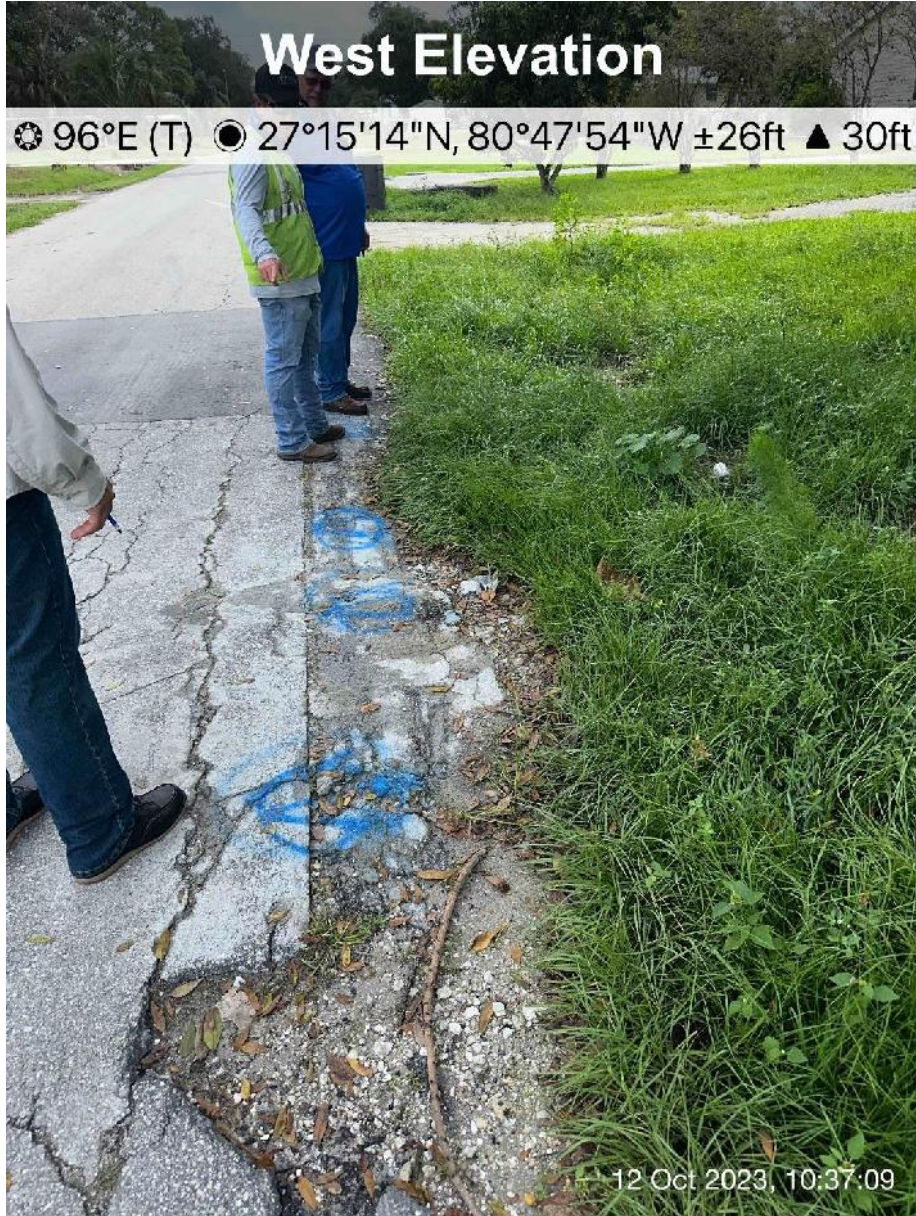

# South East Elevation

☉ 322°NW (T) ☉ 27°14'58"N, 80°47'51"W ±13ft ▲ 27ft



V:\Projects\CSFL122\Documents\Okeechobee\235-006.03 Pine Ridge Park Utility Improvements - SDC\Monthly Reports EEI\_CHA\2023\10- October\Pine Ridge Park Monthly Report - Oct 2023.docx

**OKEECHOBEE UTILITY AUTHORITY**

AGENDA ITEM NO. 11

NOVEMBER 21, 2023

**CONSENT AGENDA**

**INVOICES FROM KIMLEY HORN AND ASSOCIATES, INC. – TREASURE ISLAND  
SEPTIC TO SEWER PROJECT**

Please find attached the invoice in the amount of \$210,818.35 and \$185,479.85 submitted by Kimley Horn and Associates, Inc. Staff is aware of the work currently being done by Kimley Horn and Associates, Inc. and is in agreement with this request.

Invoice Date	Pay Request No.	Date Paid	Amt. Requested	Amount Paid	Remaining Balance
					\$3,180,385.00
Jun-23	1	Jun-23		\$10,032.10	\$3,170,352.90
Jun-23	2	Jun-23		\$106,718.65	\$3,063,634.25
Aug-23	3	Aug-23		\$36,215.50	\$3,027,418.75
Sep-23	4	Sep-23		\$20,157.35	\$3,007,261.40
Oct-23	5	Oct-23		\$25,688.60	\$2,981,572.80
Nov-23	6		\$210,818.35		\$2,770,754.45
Nov-23	7		\$185,479.85		\$2,585,274.60

**Staff recommends approval of these invoices in the amount of \$210,818.35 and \$185,479.85 to Kimley Horn and Associates, Inc.**

<p><b>Please remit payment electronically to:</b></p> <p>Account Name: KIMLEY-HORN AND ASSOCIATES, INC.          Bank Name and Address: WELLS FARGO BANK, N.A., SAN FRANCISCO, CA 94163          Account Number: 2073089159554          ABA#: 121000248</p>	<p><b>If paying by check, please remit to:</b></p> <p>KIMLEY-HORN AND ASSOCIATES, INC.          P.O. BOX 932520          ATLANTA, GA 31193-2520</p>
---	---

OKEECHOBEE UTILITY AUTHORITY  
 ATTN: JOHN HAYFORD  
 OUA  
 100 SW 5TH AVE  
 OKEECHOBEE, FL 34974

Invoice No: 26005799  
 Invoice Date: Sep 30, 2023  
 Invoice Amount: \$210,818.35  
 Project No: 241093000.1  
 Project Name: TREASURE ISLAND S2S  
 Project Manager: JENSEN, THOMAS  
 Client Reference: MSA180123  
 PO# 0000011405

Federal Tax Id: 56-0885615  
 For Services Rendered through Sep 30, 2023

**LUMP SUM**

Description	Contract Value	% Complete	Amount Earned to Date	Previous Amount Billed	Current Amount Due
Task 1 - Project Validation and Kickoff Meeting	8,284.00	100.00%	8,284.00	8,284.00	0.00
Task 2 - Data Collection	13,891.00	90.00%	12,501.90	11,807.35	694.55
Task 3 - Model Development and Hydraulic Investigation	21,804.00	0.00%	0.00	0.00	0.00
Task 4 - Preliminary Design Report (PDR)	92,037.00	70.00%	64,425.90	46,018.50	18,407.40
<b>Task 5 - Pre-Design Services</b>					
i. Geotechnical Services	31,384.00	0.00%	0.00	0.00	0.00
ii. Site Survey	603,965.00	45.00%	271,784.25	90,594.75	181,189.50
iii. Environmental Services	24,257.00	0.00%	0.00	0.00	0.00
iv. Structural Services	95,413.00	0.00%	0.00	0.00	0.00
v. Electrical, Instrumentation, Controls, and MEP Services	74,642.00	0.00%	0.00	0.00	0.00
Task 6 - Permitting and Easement/ROW Acquisition Support	159,775.00	0.00%	0.00	0.00	0.00
Task 7 - Meetings	48,503.00	0.00%	0.00	0.00	0.00
Task 8 - Project Management	38,060.00	0.00%	0.00	0.00	0.00
Task 9 - 30% Preliminary Design	526,345.00	10.00%	52,634.50	42,107.60	10,526.90
Task 10 - 60% Design	620,228.00	0.00%	0.00	0.00	0.00
Task 11 - 90% Design	504,874.00	0.00%	0.00	0.00	0.00
Task 12 - Final Design	261,335.00	0.00%	0.00	0.00	0.00
Task 13 - Bidding Services	55,588.00	0.00%	0.00	0.00	0.00
<b>Subtotal</b>	<b>3,180,385.00</b>	<b>12.88%</b>	<b>409,630.55</b>	<b>198,812.20</b>	<b>210,818.35</b>
<b>Total LUMP SUM</b>					<b>210,818.35</b>

**Total Invoice: \$210,818.35**

<p><b>Please remit payment electronically to:</b></p> <p>Account Name: KIMLEY-HORN AND ASSOCIATES, INC.          Bank Name and Address: WELLS FARGO BANK, N.A., SAN FRANCISCO, CA 94163          Account Number: 2073089159554          ABA#: 121000248</p>	<p><b>If paying by check, please remit to:</b></p> <p>KIMLEY-HORN AND ASSOCIATES, INC.          P.O. BOX 932520          ATLANTA, GA 31193-2520</p>
---	---

OKEECHOBEE UTILITY AUTHORITY  
 ATTN: JOHN HAYFORD  
 OUA  
 100 SW 5TH AVE  
 OKEECHOBEE, FL 34974

Invoice No: 26413530  
 Invoice Date: Oct 31, 2023  
 Invoice Amount: \$185,479.85  
 Project No: 241093000.1  
 Project Name: TREASURE ISLAND S2S  
 Project Manager: JENSEN, THOMAS  
 Client Reference: MSA180123  
 PO# 0000011405

Federal Tax Id: 56-0885615  
 For Services Rendered through Oct 31, 2023

**LUMP SUM**

Description	Contract Value	% Complete	Amount Earned to Date	Previous Amount Billed	Current Amount Due
Task 1 - Project Validation and Kickoff Meeting	8,284.00	100.00%	8,284.00	8,284.00	0.00
Task 2 - Data Collection	13,891.00	100.00%	13,891.00	12,501.90	1,389.10
Task 3 - Model Development and Hydraulic Investigation	21,804.00	10.00%	2,180.40	0.00	2,180.40
Task 4 - Preliminary Design Report (PDR)	92,037.00	75.00%	69,027.75	64,425.90	4,601.85
<b>Task 5 - Pre-Design Services</b>					
i. Geotechnical Services	31,384.00	0.00%	0.00	0.00	0.00
ii. Site Survey	603,965.00	70.00%	422,775.50	271,784.25	150,991.25
iii. Environmental Services	24,257.00	0.00%	0.00	0.00	0.00
iv. Structural Services	95,413.00	0.00%	0.00	0.00	0.00
v. Electrical, Instrumentation, Controls, and MEP Services	74,642.00	0.00%	0.00	0.00	0.00
Task 6 - Permitting and Easement/ROW Acquisition Support	159,775.00	0.00%	0.00	0.00	0.00
Task 7 - Meetings	48,503.00	0.00%	0.00	0.00	0.00
Task 8 - Project Management	38,060.00	0.00%	0.00	0.00	0.00
Task 9 - 30% Preliminary Design	526,345.00	15.00%	78,951.75	52,634.50	26,317.25
Task 10 - 60% Design	620,228.00	0.00%	0.00	0.00	0.00
Task 11 - 90% Design	504,874.00	0.00%	0.00	0.00	0.00
Task 12 - Final Design	261,335.00	0.00%	0.00	0.00	0.00
Task 13 - Bidding Services	55,588.00	0.00%	0.00	0.00	0.00
<b>Subtotal</b>	<b>3,180,385.00</b>	<b>18.71%</b>	<b>595,110.40</b>	<b>409,630.55</b>	<b>185,479.85</b>
<b>Total LUMP SUM</b>					<b>185,479.85</b>

**Total Invoice: \$185,479.85**



**OKEECHOBEE UTILITY AUTHORITY**

AGENDA ITEM NO. 12

NOVEMBER 21, 2023

**CONSENT AGENDA**

**INVOICE FROM THORN RUN PARTNERS**

Please see attached the Thorn Run Partners monthly invoice.

**Staff recommends approval of the monthly invoice from Thorn Run Partners in the amount of \$3,500.00.**

# THORN RUN PARTNERS



# INVOICE

Date 11/1/2023  
Invoice No. 1925

**Bill To**

Okeechobee Utility  
100 S.W. 5th Avenue  
Okeechobee, FL 34974

PO NUMBER	0000011647
SUPPLIER ID	

Terms	FOR THE MONTH OF
Net 30	November 2023

Government Relations Services performed Fee as agreed to and amount owed:	\$3,500.00
<b>Payments/Credits</b>	\$0.00
<b>Total Amount Due</b>	\$3,500.00

<b>Remittance Information</b>
For billing inquiries please email <a href="mailto:trpadmin@thornrun.com">trpadmin@thornrun.com</a>
<b>Remittance Information</b>
Please make all checks payable to: Thorn Run Partners, LLC: 100 M Street SE, Suite 750 Washington, DC 20003 Please reference the invoice number when making payment
<b>Payment Options</b>
We accept wire and ACH. For more information: Email: <a href="mailto:trpadmin@thornrun.com">trpadmin@thornrun.com</a> Phone: +1 (202) 688-0222 Online Payment Link: <a href="https://app01.us.bill.com/p/thornrunpartners">https://app01.us.bill.com/p/thornrunpartners</a>
<b>TAX ID</b>
<b>FEIN: 27-1541515</b>

**OKEECHOBEE UTILITY AUTHORITY**

AGENDA ITEM NO. 13

NOVEMBER 21, 2023

**CONSENT AGENDA**

**INVOICE FROM MACVICAR CONSULTING, INC.**

Please see attached the MacVicar Consulting Inc. invoice.

**Staff recommends approval of the monthly invoice from MacVicar Consulting Inc. in the amount of \$250.00.**



MACVICAR CONSULTING, INC.  
West Palm Beach, FL 33415

# Invoice

Okeechobee Utility Authority  
Attn:John Hayford, Exec Director  
100 SW 5th Avenue  
Okeechobee, FL 34974  
PO No:11644

DATE	INVOICE #
10/30/2023	202311013

PROJECT
<b>540.01-LOSOM Support</b>

DESCRIPTION	AMOUNT
Support for the month of October 2023	250.00
<b>Total</b>	<b>\$250.00</b>

# OKEECHOBEE UTILITY AUTHORITY

AGENDA ITEM NO. 14

NOVEMBER 21, 2023

## CUSTOMER WATER LOSS

Please find attached a request by a utility customer to speak to the OUA Board concerning a water loss on their property.



The property is a water only account. High water meter reads were reported to the property owner/manager. They eventually found a damaged water spigot on a dock at Taylor Creek. The typical monthly use is in the 300,000 – 400,000 gallons per month with the bill ranging from \$3,500 to \$5,000. From Sept 6 – Oct 3, 936,000 gallons went through the meter (\$7,820) and from Oct 3 – Nov 6, 1,238,872 gallons went through the meter (\$10,359).

A payment plan (1% interest rate) was set up: \$4,000 down and 18 monthly installments at \$350 with a final payment due of \$109.96.

OUA staff advised the owner that the payment plan is all that the OUA could offer. He asked if there was anyone else that he could talk with, and after discussing it with the Exec Director, the next stop is the OUA Board.

Please see attached a Request to Speak to the OUA Board, some flow/payment records and payment plan.



# OKEECHOBEE UTILITY AUTHORITY

100 SW 5th Avenue  
Okeechobee, Florida 34974-4221

(863) 763-9460  
Fax: (863) 763-9036

## AGENDA ITEM REQUEST FORM

Please mail or bring completed form to:

Okeechobee Utility Authority  
Executive Director Office  
100 S.W. 5<sup>th</sup> Avenue  
Okeechobee, Florida 34974-4221

NAME: GARY WRIGHT (Coastal Income Properties  
Zachary Taylor Waterfront RV Resort)  
ADDRESS: 2995 US Hwy Acc # 47313  
441 Se Okeechobee

TELEPHONE: 863-532-3201 (HOME) \_\_\_\_\_ (BUSINESS)

MEETING: REGULAR  SPECIAL  WORKSHOP  DATE: 11.21.2023 @ 8:30 A

PLEASE STATE THE ITEM YOU WISH TO HAVE PLACED ON THE OUA BOARD AGENDA:

Dispute water bill

PLEASE STATE DESIRED ACTION BY THE OUA BOARD:

Damage done by Sabotage, Trying to Reduce Bill

PLEASE SUMMARIZE PERTINENT INFORMATION CONCERNING YOUR REQUEST AND ATTACH APPLICABLE DOCUMENTS:

PRESENTATION IS TO BE MADE, HOW MUCH TIME WILL BE REQUIRED? 15 mins

SIGNED BY: [Signature]  
DATE: 13 Nov 2023

**OKEECHOBEE UTILITY AUTHORITY**

**PAYMENT AGREEMENT**

**HIGH BILL**

Okeechobee, Florida

**Property Owner Name: COASTAL INCOME PROPERTIES**

**Account Number: 47313**

**Property Address: 2995 US HWY 441**

**Route and Sequence: 305-07855**

**\$10,358.72**

**NOVEMBER 9, 2023**

The undersigned promises to pay to the order of **OKEECHOBEE UTILITY AUTHORITY**, the principle sum of TEN THOUSAND THREE HUNDRED FIFTY-EIGHT 72/00 (\$4,000.00 DOWN), being payable in lawful money of the United States or its equivalent, at **100 SW 5<sup>th</sup> Avenue, Okeechobee, FL 34974-4221**, within the time-frames and in the amounts specified below, to-wit:

**In NINETEEN (19) successive monthly installments consisting of EIGHTEEN (18) consecutive monthly payments of \$350.00 each, beginning with the DECEMBER 2023 regular monthly water/sewer billing and ending with ONE (1) final payment in the amount of \$109.96 with the JUNE 2025 regular monthly water/sewer billing. These payments will be accessed 1.0% interest; they will be due and payable at the same time each month as the regular water/sewer billing, and, if not paid by the due-date printed on the monthly bill each month, will become subject to the same penalties and late charges to which the regular monthly bill is subject.**

**PROPERTY OWNER SHALL HAVE THE RIGHT TO REPAY THIS AGREEMENT IN WHOLE OR IN PART AT ANYTIME WITHIN THE LIFE OF THIS AGREEMENT WITHOUT PENALTY.**

**SALE/TRANSFER OR/AND CHANGE OF UTILITY ACCOUNT HOLDER**

**The entire principal sum shall become immediately due and payable upon the sale or transfer of the property or before a tenant opens a new utility account in his/her name for the subject property**

**Customer Initials \_\_\_\_\_**

**AGREEMENT AS N Under Sections 153.7 and 159.18(2), FLA. STAT., this agreement shall constitute a lien on the subject property. Said lien is effective and binding against the subject property in accordance with Florida Law.**

**Customer Initials** \_\_\_\_\_

Each property owner and endorser waives demand, protest and notice of maturity, non-payment or protest and an all requirements necessary to hold each of them liable as makers and endorsers.

Each property owner and endorser further agrees, jointly and severally, to pay all costs of collection, including a reasonable attorney's fee in case the principal of this note or any payment on the principal or any interest thereon is not paid at the respective maturity thereof, or in case it becomes necessary to protect the security hereof, whether suit be brought or not.

Name: \_\_\_\_\_ Signature: \_\_\_\_\_

Address: \_\_\_\_\_

Name: \_\_\_\_\_ Signature: \_\_\_\_\_

Address: \_\_\_\_\_

**STATE OF** \_\_\_\_\_

**COUNTY OF** \_\_\_\_\_

The foregoing instrument was acknowledged before me this \_\_\_\_\_ day of \_\_\_\_\_, 20\_\_\_\_, by \_\_\_\_\_ who is personally known to me or who produced a \_\_\_\_\_ as identification and who did take an oath.

\_\_\_\_\_  
**Notary Public**



# Loan Amortization Schedule

Enter values	
Loan amount	\$ 6,358.72
Annual interest rate	1.00 %
Loan period in years	1
Number of payments per year	12
Start date of loan	11/7/2023
Optional extra payments	\$ -

Loan summary	
Scheduled payment	\$ 350.00
Scheduled number of payments	19
Actual number of payments	19
Total early payments	\$ -
Total interest	\$ 51.33

\$10,358.72 (\$4,000.00 Down)

Coastal Income Properties  
2995 US HWY 441 SE

Lender name:

Pmt No.	Payment Date	Beginning Balance	Scheduled Payment	Payment	Total Payment	Principal	Interest	Ending Balance	Cumulative Interest
1	1/1/2024	\$ 6,358.72	\$ 350.00	\$ -	\$ 350.00	\$ 344.70	\$ 5.30	\$ 6,014.02	\$ 5.30
2	2/1/2024	6,014.02	350.00	-	350.00	344.99	5.01	5,669.03	10.31
3	3/1/2024	5,669.03	350.00	-	350.00	345.28	4.72	5,323.75	15.03
4	4/1/2024	5,323.75	350.00	-	350.00	345.56	4.44	4,978.19	19.47
5	5/1/2024	4,978.19	350.00	-	350.00	345.85	4.15	4,632.34	23.62
6	6/1/2024	4,632.34	350.00	-	350.00	346.14	3.86	4,286.20	27.48
7	7/1/2024	4,286.20	350.00	-	350.00	346.43	3.57	3,939.77	31.05
8	8/1/2024	3,939.77	350.00	-	350.00	346.72	3.28	3,593.06	34.34
9	9/1/2024	3,593.06	350.00	-	350.00	347.01	2.99	3,246.05	37.33
10	10/1/2024	3,246.05	350.00	-	350.00	347.29	2.71	2,898.75	40.03
11	11/1/2024	2,898.75	350.00	-	350.00	347.58	2.42	2,551.17	42.45
12	12/1/2024	2,551.17	350.00	-	350.00	347.87	2.13	2,203.30	44.58
13	1/1/2025	2,203.30	350.00	-	350.00	348.16	1.84	1,855.13	46.41
14	2/1/2025	1,855.13	350.00	-	350.00	348.45	1.55	1,506.68	47.96
15	3/1/2025	1,506.68	350.00	-	350.00	348.74	1.26	1,157.93	49.21
16	4/1/2025	1,157.93	350.00	-	350.00	349.04	0.96	808.90	50.18
17	5/1/2025	808.90	350.00	-	350.00	349.33	0.67	459.57	50.85
18	6/1/2025	459.57	350.00	-	350.00	349.62	0.38	109.96	51.24
19	7/1/2025	109.96	350.00	-	109.96	109.86	0.09	0.00	51.33

# Utility Billing

## Account History Report

User: mwilloughby  
 Printed: 11/14/2023 - 3:10PM



**Account Status:** Active  
**Connect Date:** 05/20/2016      **Final Date:**  
**Customer Name:** COASTAL INCOME PROPERTIES  
**Care Of:** ZACHARY TAYLOR LLC  
**Customer Address:** 2840 WEST BAY DRIVE #174  
 BELLEAIR BLUFFS, FL 33770

**Total Account Balance:** 10,358.72  
**Total Deposits:** 4,200.00      **Total Refunds:** 4,200.00

**Owner Name:**  
**Service Address:** 2995 US HIGHWAY 441 SE

**Home Phone:** (863) 532-3801      **Ext:** 0  
**Business Phone:**                      **Ext:** 0  
**Account Number:** 047313-000      **Reference Number:** 30507855

Tran Date	Tran Type	Description	Amount	WATER CPA	SEWER N/A	FRAN N/A	FIRE PRO N/A	MISC N/A	PENALTY N/A	OVRPAY N/A	DEP N/A
<b>Current Balance By Service</b>				10,358.72	0.00	0.00	0.00	0.00	0.00	0.00	0.00
				0.00	0.00	0.00	0.00	0.00	0.00	0.00	0.00
11/14/2023	Balance		10,358.72	10,358.72	0.00	0.00	0.00	0.00	0.00	0.00	0.00
				0.00							
11/14/2023	Billing		10,358.72	10,358.72	0.00	0.00	0.00	0.00	0.00	0.00	0.00
				0.00							
11/06/2023	Payment	Clearing House	-7,821.89	-7,821.89	0.00	0.00	0.00	0.00	0.00	0.00	0.00
				0.00							
10/16/2023	Balance		7,821.89	7,821.89	0.00	0.00	0.00	0.00	0.00	0.00	0.00
				0.00							
10/16/2023	Billing		7,821.89	7,821.89	0.00	0.00	0.00	0.00	0.00	0.00	0.00
				0.00							
10/05/2023	Payment	Clearing House	-3,257.49	-3,257.49	0.00	0.00	0.00	0.00	0.00	0.00	0.00
				0.00							
09/14/2023	Balance		3,257.49	3,257.49	0.00	0.00	0.00	0.00	0.00	0.00	0.00
				0.00							
09/14/2023	Billing		3,257.49	3,257.49	0.00	0.00	0.00	0.00	0.00	0.00	0.00
				0.00							

# Utility Billing

## Account History Report



User: mwilloughby  
 Printed: 11/14/2023 - 3:05PM

Account Status: Active  
 Connect Date: 05/20/2016 Final Date:  
 Customer Name: COASTAL INCOME PROPERTIES  
 Care Of: ZACHARY TAYLOR LLC  
 Customer Address: 2840 WEST BAY DRIVE #174  
 BELLEAIR BLUFFS, FL 33770

Total Account Balance: 10,358.72  
 Total Deposits: 4,200.00 Total Refunds: 4,200.00

Owner Name:  
 Service Address: 2995 US HIGHWAY 441 SE

Home Phone: (863) 532-3801 Ext: 0  
 Business Phone: Ext: 0  
 Account Number: 047313-000 Reference Number: 30507855

Tran Date	Tran Type	Description	Amount	WATER CPA	SEWER N/A	FRAN N/A	FIRE PRO N/A	MISC N/A	PENALTY N/A	OVRPAY N/A	DEP N/A
		Current Balance By Service		10,358.72	0.00	0.00	0.00	0.00	0.00	0.00	0.00
				0.00	0.00	0.00	0.00	0.00	0.00	0.00	0.00
			0.00	0.00	0.00	0.00	0.00	0.00	0.00	0.00	0.00
				0.00							

Description	Read Date	Reading	Consumption
<b>Active</b>			
Route-Sequence-Serial: 305-07855-86837569			
reck-m/run-office to call	11/6/2023	13,766,406	1,238,872.00
	10/3/2023	12,527,534	936,668.00
	9/6/2023	11,590,866	293,861.00
	8/7/2023	11,297,005	565,646.00
	6/29/2023	10,731,359	324,927.00
	6/6/2023	10,406,432	405,406.00
	5/4/2023	10,001,026	306,995.00
	4/3/2023	9,694,031.0	378,151.00
	3/4/2023	9,315,880.0	590,908.00
	2/2/2023	8,724,972.0	577,272.00
	1/3/2023	8,147,700.0	379,980.00
	12/6/2022	7,767,720.0	424,269.00
	11/3/2022	7,343,451.0	327,657.00

# OKEECHOBEE UTILITY AUTHORITY

## AGENDA ITEM NO. 15

NOVEMBER 21, 2023

### FINANCE REPORT

At the end of October 2023, first month of FY24, operating revenue were \$1,022,513 compare to budget of \$1,077,569 resulting in the achievement of 94.9% of YTD budget or a deficit of \$55,056 or (5.1%). While there wasn't any noticeable factor impacting the below budget performance, a comparative review of the Authority's revenue performance for the same period last year, October 2022, shows an equally slow start to the financial year which accelerated as the year progress.

Revenue for water and wastewater during the month are shown below:

	<u>Actual</u>	<u>Budget</u>	<u>Variance</u>
	\$	\$	\$
Water	594,619	638,886	(44,267)
Wastewater	366,276	396,392	(30,116)

Despite the slight adverse variance on base and volumetric charge for water and wastewater for the month, wastewater installation/connection fee for Pine Ridge Park and South West Service Area, continue to have a positive impact on revenue with a realization of \$18,600 compare to budget of \$5,180 (refer to page 16).

YTD operating expenditures were \$611,379 compare to budget of \$846,444, yielding a positive variance of \$231,125 or 27.8%. This is expected during the initial months of the fiscal year, due to the scheduling of major maintenance and purchases later in the financial year.

Non-operating expenses of \$263,785 which comprises of depreciation and loan interest were in line with the month's budget of \$264,240.

Restricted revenue of \$81,184 is 129.3% above YTD budget of \$35,407. Accounting for this variance are:

1. Infill revenue from wastewater was \$27,156 compare to budget of \$7,821. Residents from the two communities mentioned above, continue to sign up for service.
2. Interest revenue of \$36,035 achieved during the month compare to budget of \$15,898. While the month's average balances were above budgeted cash balance, the budget project a reduction in interest for FY24 to 2% compare to the 3.56% realized during the month on bank balances.

# **Okeechobee Utility Authority**

## **Finance Report**

### **Fiscal Year 2024**

**As of                      The Period Ending                      October 31, 2023**

OKEECHOBEE UTILITY AUTHORITY  
TABLE OF CONTENTS

Executive Summary	Page 1
Finance Report for: The Period Ending October 31, 2023	Page 2
Graphs:	
Operating Revenue Comparison- YTD Actual vs Budget	Page 3
Operating Expenses Comparison- YTD Actual vs Budget	Page 3
Operating Activity Comparisons:	
Revenue-Current Year vs 4 Year Weighted Average vs Current YTD Budget	Page 4
Graph-Current Year vs 4 Year Weighted Average YTD	Page 5
Graph-Water Revenue FY17-FY22 & FY23 YTD	Page 6
Graph-Sewer Revenue FY17-FY22 & FY23 YTD	Page 7
Expenses-Current Year vs 4 Year Weighted Average vs Current YTD Budget	Page 8
Graph-Current Year vs 4 Year Weighted Average YTD	Page 9
Graph Operating Expenses FY17-FY22 & FY23 YTD	Page 10
Graph Non Operating Expenses FY17-FY22 & FY23 YTD	Page 11
Comparative Statement of Cashflows: 09.3.21, 09.30.22 & 10.31.23	Page 12
Balance Sheet as of October 31, 2023	Pages 13-14
Pie Graph of Major Balance Sheet Items	Page 15
Detail of Other Operating Revenue	Page 16

Okeechobee Utility Authority  
 Executive Summary  
 Prepared by Finance Director

**OKEECHOBEE UTILITY AUTHORITY  
 FINANCIAL SUMMARY COMPARISON**

	Operating Revenues				Operating Expenses				Restricted Revenues				Cumulative YTD Restricted Budget Variance	
	Actual FY23	YTD FY24	Actual YTD FY24	Budget YTD FY24	% Variance (FY 24 vs Bud. FY24)	Actual YTD FY23	Actual YTD FY24	Budget YTD FY24	% Variance (FY24 vs Bud FY24)	Actual YTD FY 23	Actual YTD FY 24	Budget YTD FY24		% Variance (FY 24 vs Bud FY 24)
Oct-23	987,911		1,022,513	1,077,569	-5.1%	520,371	611,379	846,444	27.8%	19,502	81,184	35,407	129.3%	45,777
Nov-23														
Dec-23														
Jan-24														
Feb-24														
Mar-24														
Apr-24														
May-24														
Jun-24														
Jul-24														
Aug-24														
Sep-24														

Respectfully,  
  
 Lauriston Hamilton

**Okeechobee Utility Authority**  
**FY 2024 Finance Report for Oct. 31, 2023**  
**The Period Ending**

**OPERATING REVENUE FUND**

	Actual YTD	Budget YTD	\$ Variance	% Variance
<b>OPERATING REVENUE:</b>				
Water	\$ 594,687	\$ 640,386	\$ (45,699)	-7.1%
Sewer	\$ 366,276	397,453	(31,177)	-7.8%
Other Operating Revenue (see detail on page 16)	\$ 61,551	39,730	21,821	54.9%
Total Operating Revenue Received	<u>\$ 1,022,513</u>	<u>\$ 1,077,569</u>	<u>\$ (55,056)</u>	<u>-5.1%</u>
<b>OPERATING EXPENSES:</b>				
Water	\$ 133,616	\$ 191,607	\$ 57,991	30.3%
Wastewater	\$ 81,819	117,430	35,610	30.3%
Meter Readers	\$ 22,918	30,839	7,920	25.7%
Maintenance	\$ 192,537	250,625	58,088	23.2%
Administration Operating	\$ 95,088	155,671	60,582	38.9%
General & Admin.	\$ 85,400	100,273	14,873	14.8%
Contingency Expense	\$ -	-	-	0.0%
Total Operating Expenses Paid (3) (4) (5) (6)	<u>\$ 611,379</u>	<u>\$ 846,444</u>	<u>\$ 235,065</u>	<u>27.8%</u>
<b>Net Operating Income</b>	<u>\$ 411,134</u>	<u>\$ 231,125</u>	<u>\$ 180,009</u>	<u>77.9%</u>

**RESTRICTED REVENUE FUNDS**

<b>RESTRICTED REVENUE FUNDS RECEIVED:</b>				
Fire Hydrant Fund Fee	\$ 8,070	\$ 7,917	\$ 153	1.9%
Water CC Fees (infill)	\$ 9,922	3,771	6,151	163.1%
WW CC Fees (infill)	\$ 27,156	7,821	19,335	247.2%
Operating Account Interest	\$ 26,322	11,348	14,975	0.0%
Payroll Account Interest	\$ 424	201	224	0.0%
Restricted Interest Income	\$ 9,289	4,349	4,940	113.6%
<b>TOTAL RESTRICTED REVENUE (1) (2)</b>	<u>\$ 81,184</u>	<u>\$ 35,407</u>	<u>\$ 45,776</u>	<u>129.3%</u>
<b>NON-OPERATING EXPENSES:</b>				
Debt service interest expense	\$24,140	\$31,925	7,785	24.4%
Non-cash depreciation & amortization	\$239,645	\$232,315	(7,329)	-3.2%
<b>NET REVENUE BEFORE ITEMS BELOW</b>	<u>\$ 228,534</u>	<u>\$ 2,293</u>	<u>\$ 225,330</u>	<u>9827.9%</u>

**NOTES:** Above Revenue and Expense does not include the following:

	Actual YTD	Annual Budget	Variance
(1) Grant funds & state appropriations of:	\$48,748	\$11,793,240	
(2) Contributed capital of:	\$0	\$20,145	
(3) Debt service principal payments of:	\$0	\$2,153,619	
(4) Net Construction In Progress (CIP) Expenditures of:	\$0	\$11,548,847	



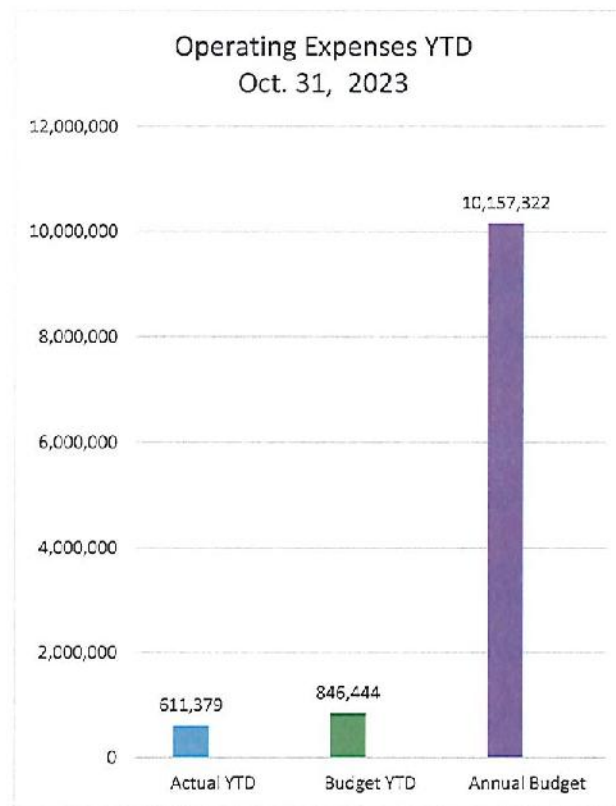
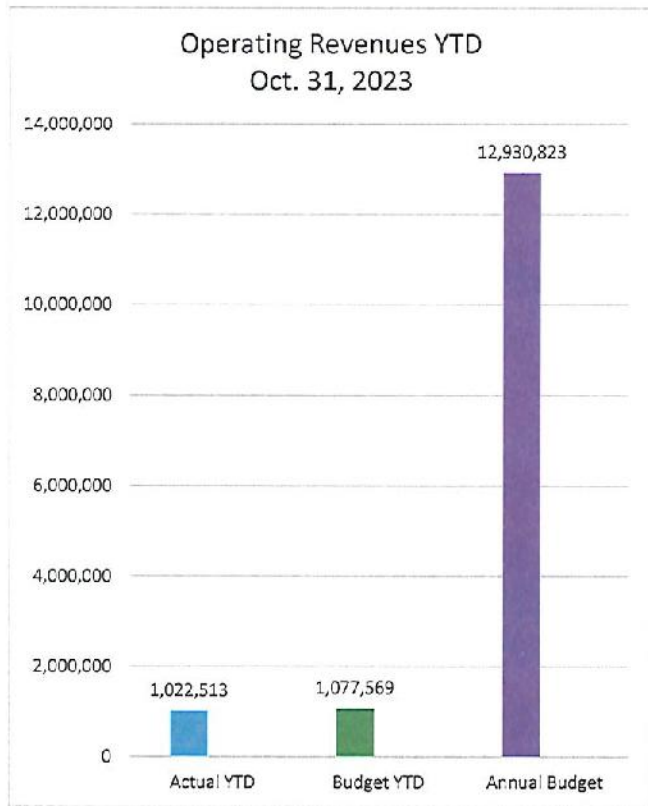

**Current FY-24 Water and Sewer Utility Revenue**  
**Monthly & YTD Revenue and Difference from 4Yr Weighted Average (in \$)**

<b>WATER UTILITY REVENUE:</b>				<b>Monthly \$ Difference From 4 Year Weighted Average of</b>	<b>% Current YTD Budget</b>	<b>4 Yr Weighted Average %</b>
<b>Period</b>	<b>YTD</b>		<b>\$ 6,657,165</b>	<b>Water Revenue</b>		
				<b>\$7,666,630</b>		
Oct.	\$ 594,619	594,619	\$ 61,516		7.76%	8.00%
Nov.	\$ -	-	\$ -		0.00%	0.00%
Dec.	\$ -	-	\$ -		0.00%	0.00%
Jan.	\$ -	-	\$ -		0.00%	0.00%
Feb.	\$ -	-	\$ -		0.00%	0.00%
Mar.	\$ -	-	\$ -		0.00%	0.00%
Apr.	\$ -	-	\$ -		0.00%	0.00%
May	\$ -	-	\$ -		0.00%	0.00%
Jun.	\$ -	-	\$ -		0.00%	0.00%
Jul.	\$ -	-	\$ -		0.00%	0.00%
Aug.	\$ -	-	\$ -		0.00%	0.00%
Sep.	\$ -	-	\$ -		0.00%	100.00%

  

<b>SEWER UTILITY REVENUE:</b>				<b>Monthly \$ Difference From 4 Year Weighted Average of</b>	<b>% Current YTD To Budgeted Sewer Revenue</b>	
			<b>\$ 4,078,267</b>	<b>\$4,756,702</b>		
Oct.	\$ 366,276	\$ 365,608	\$ 35,300		7.69%	8.12%
Nov.	\$ -	\$ -	\$ -		0.00%	0.00%
Dec.	\$ -	-	\$ -		0.00%	0.00%
Jan.	\$ -	-	\$ -		0.00%	0.00%
Feb.	\$ -	-	\$ -		0.00%	0.00%
Mar.	\$ -	-	\$ -		0.00%	0.00%
Apr.	\$ -	-	\$ -		0.00%	0.00%
May	\$ -	-	\$ -		0.00%	0.00%
Jun.	\$ -	-	\$ -		0.00%	0.00%
Jul.	\$ -	-	\$ -		0.00%	0.00%
Aug.	\$ -	-	\$ -		0.00%	0.00%
Sep.	\$ -	-	\$ -		0.00%	100.00%

## WATER AND SEWER REVENUE COMPARISON YEAR TO DATE vs 4 YEAR WEIGHTED AVERAGE YEAR TO DATE

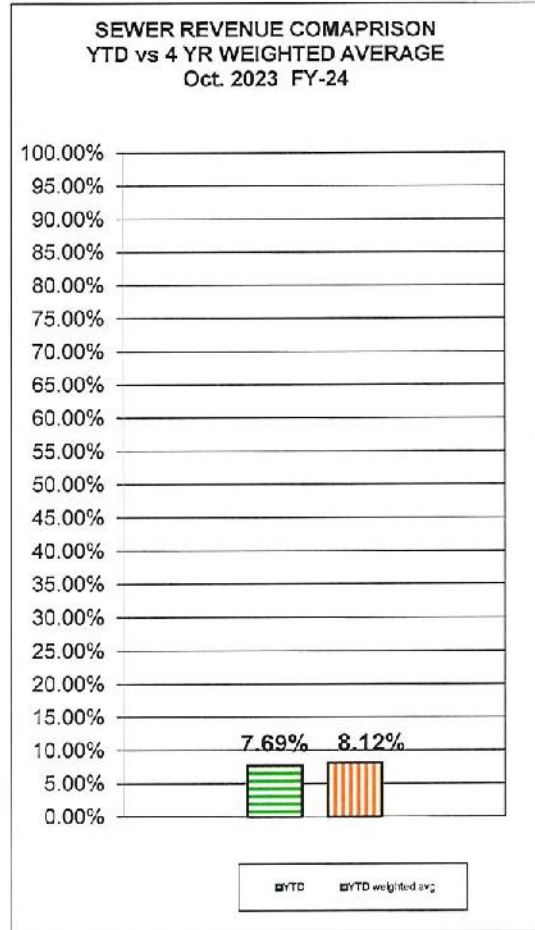
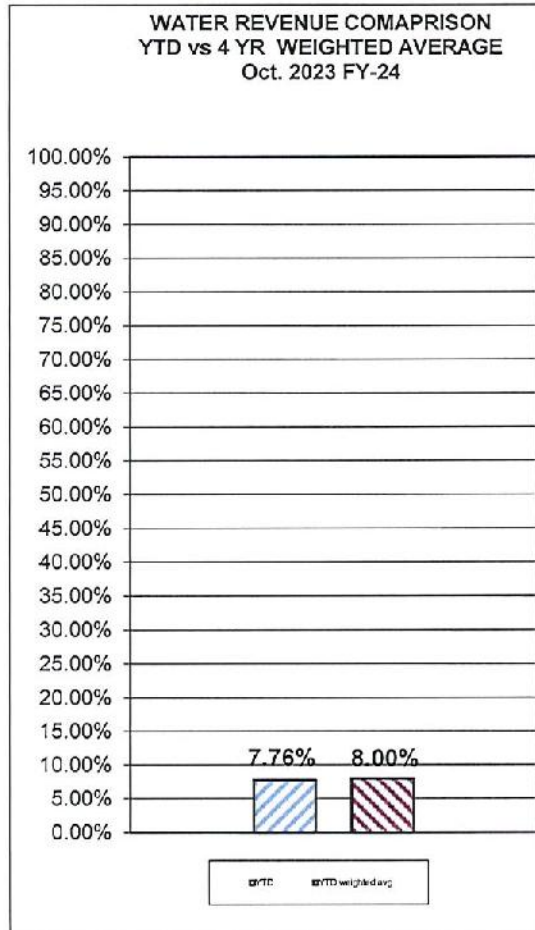

### Actual Water Revenue Comparison

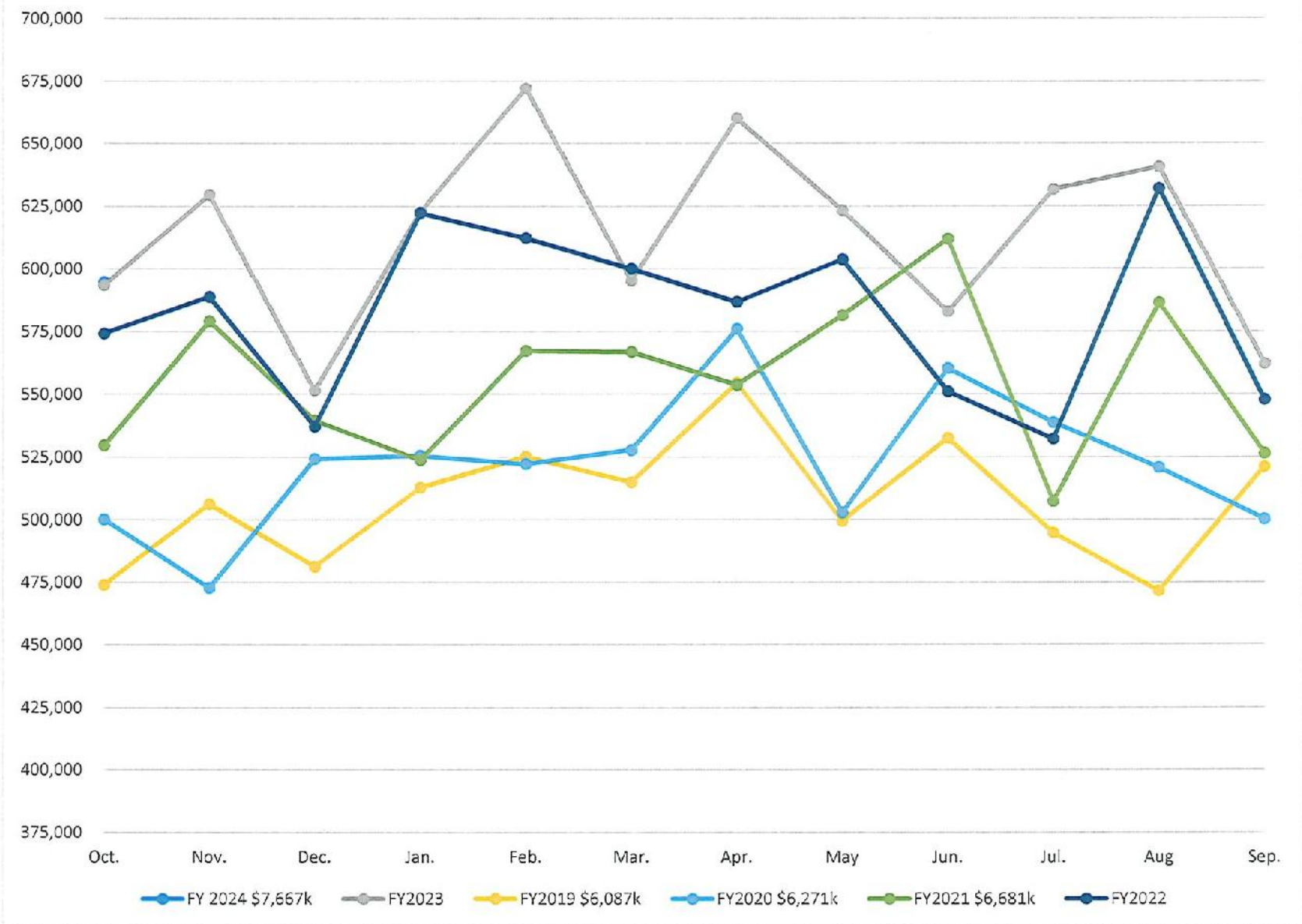

### Actual Wastewater Revenue Comparison

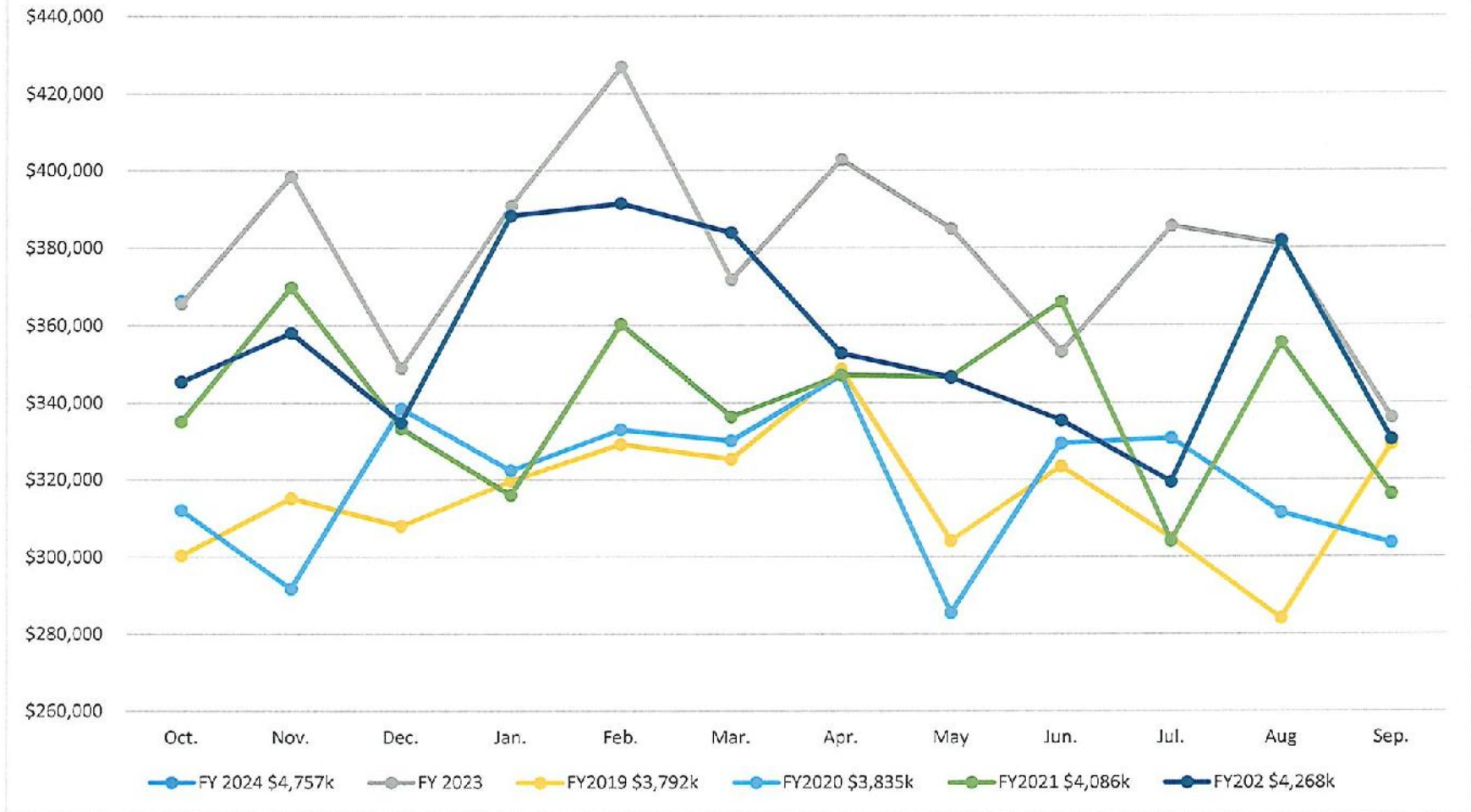

**Current FY-24 Operating & Non-Operating Expenses,  
Monthly & YTD Expense and Difference from 4Yr Weighted Average (in \$)**

OPERATING EXPENSES:			\$ Difference For the Month	% Current YTD To Budgeted	4 Yr Weighted Average
			From 4 Year Weighted Avg of	Operating Exp.	
Period	YTD		\$ 6,806,185	\$10,157,322	
Oct.	\$ 611,379	\$ 611,379	\$ 192,149	6.02%	6.19%
Nov.	\$ -	\$ -	\$ -	0.00%	0.00%
Dec.	\$ -	\$ -	\$ -	0.00%	0.00%
Jan.	\$ -	\$ -	\$ -	0.00%	0.00%
Feb.	\$ -	\$ -	\$ -	0.00%	0.00%
Mar.	\$ -	\$ -	\$ -	0.00%	0.00%
Apr.	\$ -	\$ -	\$ -	0.00%	0.00%
May	\$ -	\$ -	\$ -	0.00%	0.00%
Jun.	\$ -	\$ -	\$ -	0.00%	0.00%
Jul.	\$ -	\$ -	\$ -	0.00%	0.00%
Aug.	\$ -	\$ -	\$ -	0.00%	0.00%
YTD	\$ 611,379	\$ 611,379	\$ -	6.02%	100.00%
NON-OPERATING EXPENSES:			\$ Difference For the Month	% Current YTD To Budgeted	
			From 4 Year Weighted Avg of	Non-Oper. Exp.	
			\$ 3,102,121	\$3,170,877	
Oct.	\$ 263,784	\$ 263,784	\$ 9,263	8.32%	8.21%
Nov.	\$ -	\$ -	\$ -	0.00%	16.35%
Dec.	\$ -	\$ -	\$ -	0.00%	24.49%
Jan.	\$ -	\$ -	\$ -	0.00%	32.63%
Feb.	\$ -	\$ -	\$ -	0.00%	40.79%
Mar.	\$ -	\$ -	\$ -	0.00%	49.00%
Apr.	\$ -	\$ -	\$ -	0.00%	57.05%
May	\$ -	\$ -	\$ -	0.00%	65.10%
Jun.	\$ -	\$ -	\$ -	0.00%	73.15%
Jul.	\$ -	\$ -	\$ -	0.00%	81.21%
Aug.	\$ -	\$ -	\$ -	0.00%	89.18%
YTD	\$ 263,784	\$ 263,784	\$ -	8.32%	100.00%

**NON-OPERATING EXPENSES COMAPRISON  
YTD vs 4 YR WEIGHTED AVERAGE YTD**

Oct. 2023 FY-24

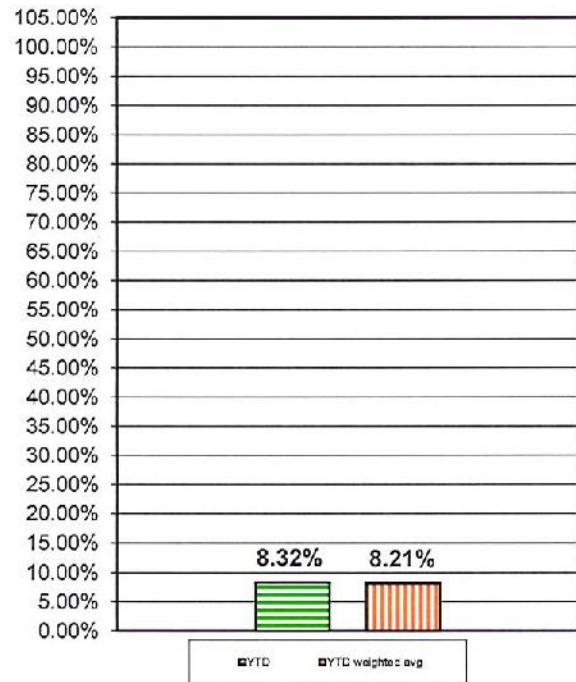

**OPERATING EXPENSES COMAPRISON  
YTD vs 4 YR WEIGHTED AVERAGE YTD**

Oct. 2023 FY-24

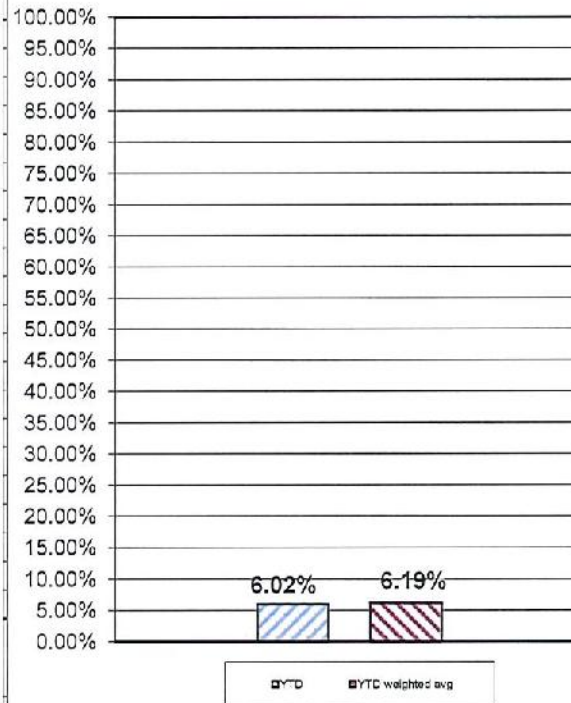

### Actual Operating Expense Comparison

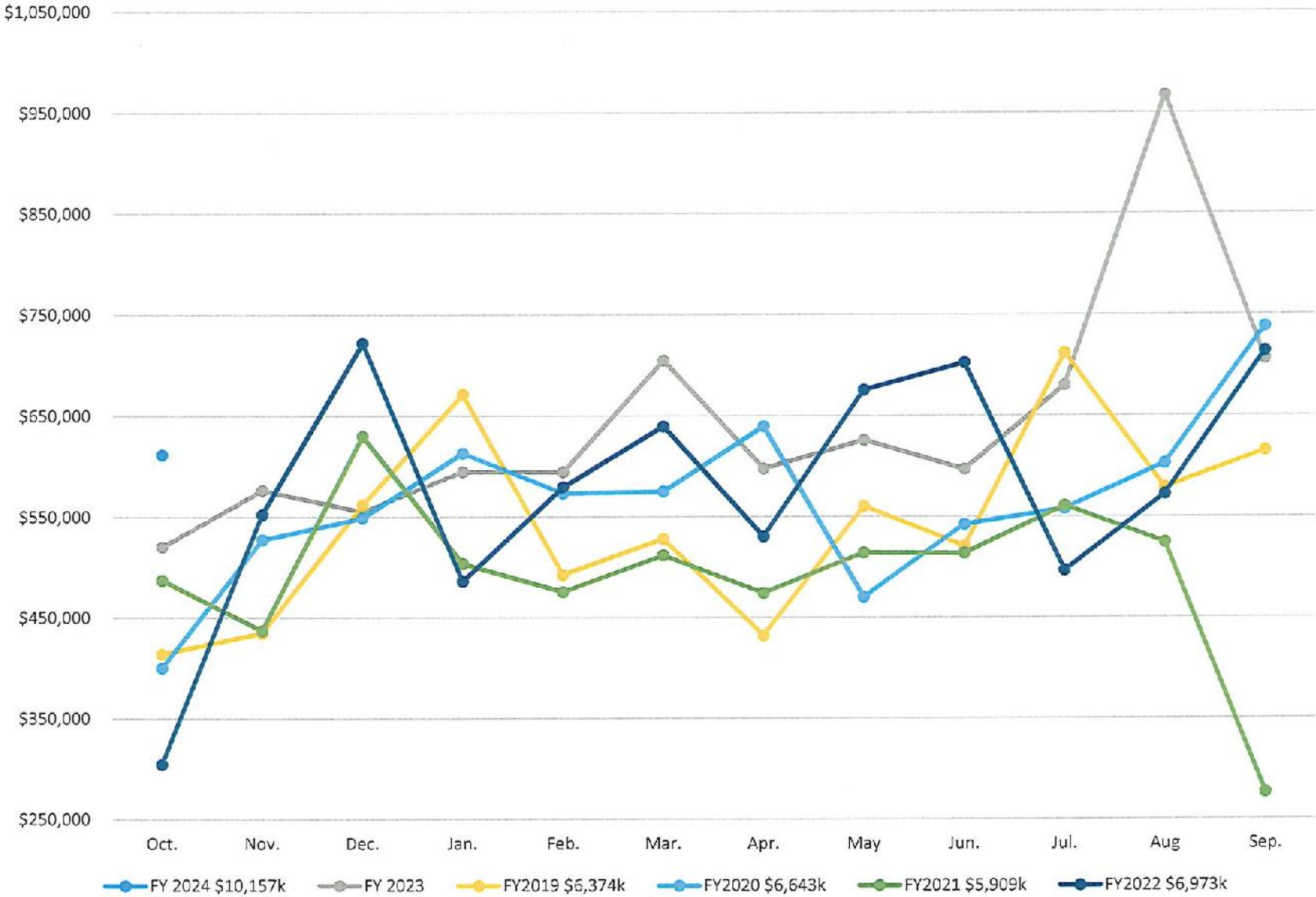



### Actual Non Operating Expense Comparison

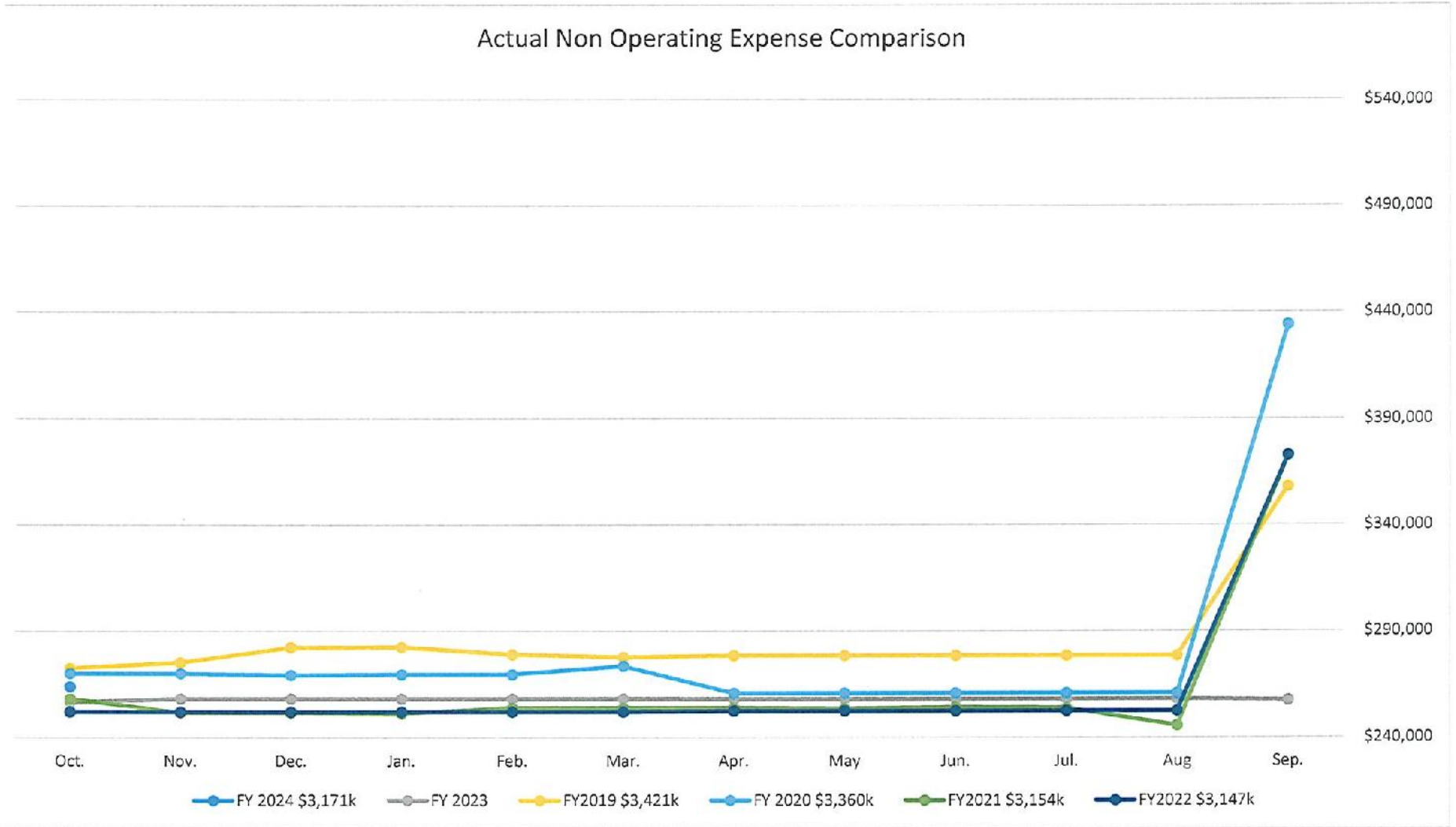

	A	X	Z	AA	AC
49					(1,395,317)
50	<b>Okeechobee Utility Authority</b>				
51	<b>Income Statement</b>				
52		<b>Sept 30, 2021</b>		<b>Sept 30, 2022</b>	<b>Oct. 31, 2023</b>
53		<b>12 Months</b>		<b>12 Months</b>	<b>1 Month</b>
54					
55	<b>Operating Revenue</b>				
56	Water system services	6,949,975		7,285,294	594,687
57	Wastewater system services	4,105,049		4,306,134	366,276
58	Penalties and late charges	121,010		124,598	9,179
59	Gain (loss) on sale of land and equipment	\$ 37,022		37,022	-
60	Miscellaneous	43,200		92,004	52,372
61	<b>Total operating revenues</b>	<b>11,256,256</b>		<b>11,845,052</b>	<b>1,022,513</b>
62	<b>Operating Expenses</b>				
63	Water	\$ 1,327,971		1,586,181	133,616
64	Wastewater	\$ 895,605		1,162,261	81,819
65	Maintenance	\$ 1,884,663		2,286,343	192,537
66	Meter reader	\$ 207,587		270,156	22,918
67	Administration & General	1,593,220		1,970,902	180,488
68	Depreciation & amortization	2,630,852		2,688,584	239,645
69	<b>Total operating expenses</b>	<b>8,539,898</b>		<b>9,964,427</b>	<b>851,023</b>
70					
71	<b>Operating Income</b>	<b>2,716,358</b>		<b>1,880,625</b>	<b>171,490</b>
72					
73	<b>Nonoperating Revenues/Expenses</b>				
74	Operating Grants (FEMA reimbursement)	\$ -		44,987	90,083
75	Debt issuance costs	\$ -		0	0
76	Interest revenue	47,914		29,488	36,036
77	Interest expense	\$ (523,113)		(472,215)	(24,140)
78	<b>Total Nonoperating Revenues/Expenses</b>	<b>(475,199)</b>		<b>(397,740)</b>	<b>101,979</b>
79					
80	State of Florida Capital Grants	\$ 1,497,834		2,700,665	-
81	Fire Hydrant fees				8,070
82	Water Capital connection fees	83,437		61,737	9,922
83	Wastewater Capital connection fees	146,781		60,585	27,156
84	Developer capital contributions	78,020		32,358	-
85	<b>Total capital contributions</b>	<b>1,806,072</b>		<b>2,855,345</b>	<b>45,148</b>
86					
87	<b>Change in net position</b>	<b>4,047,231</b>		<b>4,338,230</b>	<b>318,617</b>

**OKEECHOBEE UTILITY AUTHORITY**  
**Statement of Net Assets**  
**October 31, 2023**

ASSETS

CURRENT ASSETS

Cash and cash equivalents		\$	4,581,880.64
Unrestricted assets:			
Investments			0.00
Interest receivable			0.00
Grants receivable			
Restricted assets:			
Cash and cash equivalents			8,508,770.34
Investments			0.00
Interest receivable			0.00
Receivables:			
Accounts receivable			1,659,238.30
less allowance for uncollectible accounts			(102,005.35)
Inventories			611,432.44
Prepaid Expenses			75,041.96
Total current assets			15,334,358.33

NONCURRENT ASSETS

Capital assets:

Land			2,906,860.90
Utility plants, buildings and equipment			109,859,285.53
			112,766,146.43
Less accumulated depreciation			(54,390,166.79)
			58,375,979.64
Construction in progress			13,353,357.89
Total capital assets			71,729,337.53

Other Assets:

Net Pension Asset			0.00
-------------------	--	--	------

Deferred Charges:

Deferred Pension Outflows - Actuarial and Prepaid			1,793,819.00
Deferred loss on bond refunding, net			321,397.28
Total Deferred charges:			2,115,216.28

Total noncurrent assets			73,844,553.81
-------------------------	--	--	---------------

TOTAL ASSETS		\$	89,178,912.14
--------------	--	----	---------------

LIABILITIES AND NET ASSETS

CURRENT LIABILITIES

Accounts payable	616,656.21
Accrued expenses	149,139.39
Due to other governments	71,338.62
Bonds payable (current)	-0.01
Accrued compensated absences & bonus (current)	381,715.98

Payable from restricted assets	
Accrued interest	26,864.11
Customer Deposits	662,847.71

Total current liabilities	<u>1,908,562.01</u>
---------------------------	---------------------

NONCURRENT LIABILITIES

Long-term portion of bonds payable, net	14,955,003.52
Accrued OPEB payable	219,174.00
Net Pension Liability	875,759.00
Deferred Pension Inflow from Actuarial Calculation	579,918.00
Unearned revenues:	

Developer agreements	424,402.36
----------------------	------------

Total noncurrent liabilities	<u>17,054,256.88</u>
------------------------------	----------------------

TOTAL LIABILITIES	<u>18,962,818.89</u>
-------------------	----------------------

NET POSITION

Invested in capital assets, net of related debt	44,731,657.00
Restricted for capital projects	2,361,411.00
Restricted for debt service	481,018.00
Restricted for Rate Stabilization	1,339,359.00
Restricted for Pension Benefits	1,904,107.00
Unrestricted	19,130,657.86
YTD Surplus of Revenue over Expenses	267,883.39

Total net position	<u>70,216,093.25</u>
--------------------	----------------------

TOTAL LIABILITIES AND NET POSITION	<u>\$ 89,178,912.14</u>
------------------------------------	-------------------------

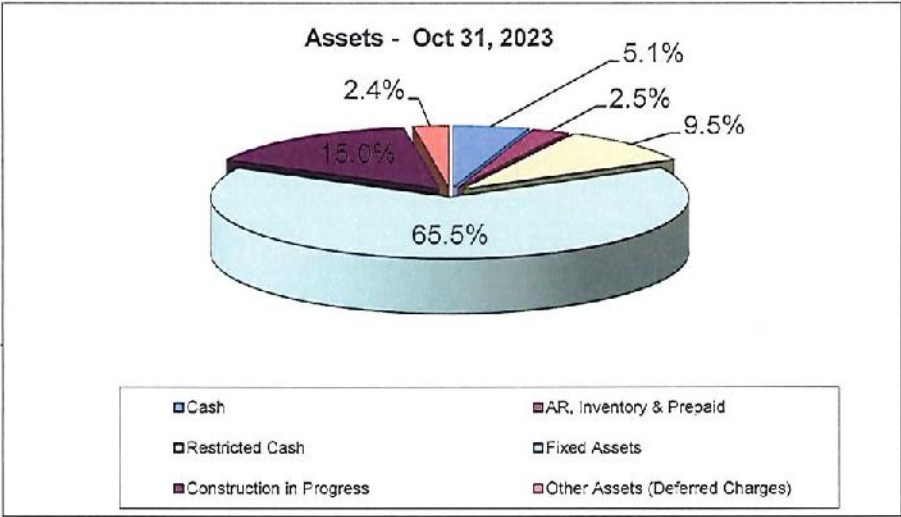

Cash	4,581,881	5.1%
AR, Inventory & Prepaid	2,243,707	2.5%
Restricted Cash	8,508,770	9.5%
Fixed Assets	58,375,980	65.5%
Construction in Progress	13,353,358	15.0%
Other Assets (Deferred Charges)	2,115,216	2.4%
<b>Total Assets</b>	<b>89,178,912</b>	

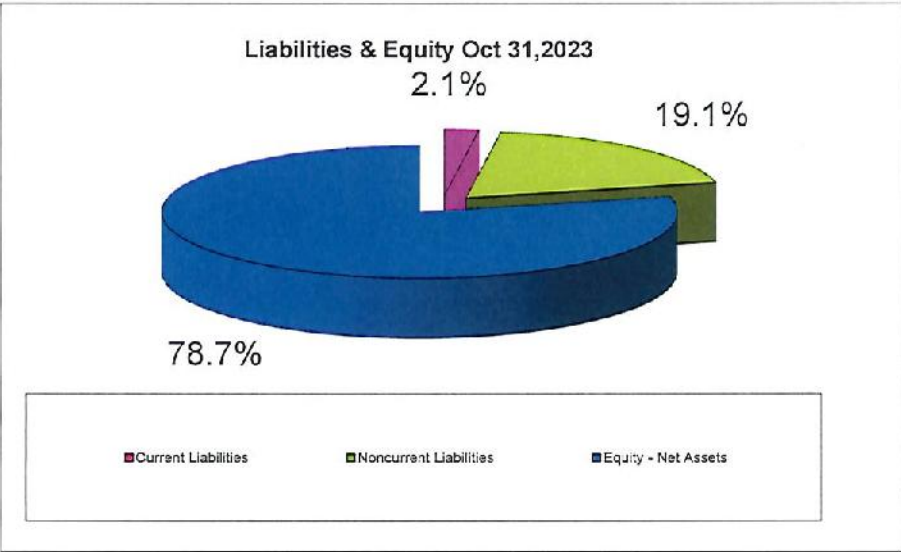

Current Liabilities	1,908,562	2.1%
Noncurrent Liabilities	17,054,257	19.1%
Equity - Net Assets	70,216,093	78.7%
<b>Total Liab &amp; Equity</b>	<b>89,178,912</b>	

**Okeechobee Utility Authority**  
**Detail of October 31, 2023 Other Operating Revenue**  
**Data Per General Ledger Account Balances For Finance Report**

Accounts included in Other Operating Revenue:	Actual Amount YTD	Amount Per Budget YTD	\$ Variance From Budget YTD
Install Fees-Water	\$ -	\$ 2,328	\$ (2,328)
Private Fire Protection	\$ 7,301	8,034	(733)
Turn on/off Fees	\$ 4,860	4,491	370
Other Revenue-Water           A	\$ 825	1,262	(437)
Install Fees-Sewer	\$ 18,600	5,180	13,420
Kings Bay Sewer Maint. Fees	\$ 1,641	1,717	(76)
Other Revenue-Sewer           B	\$ -	336	(336)
Penalties & Late Charges	\$ 9,179	6,477	2,701
Gain/Loss Sale of Assets       C	\$ 0	0	0
Ag Land Lease	\$ -	292	(292)
Merchant & Misc. Revenue     D	\$ 19,145	9,613	9,532
<b>Totals</b>	<b>\$ 61,551</b>	<b>\$ 39,730</b>	<b>\$ 21,821</b>

- A Other Revenue-Water includes:
  - Water service inspection fees
  - Backflow prevention fees
  - After hours charges
  - Meter relocation charges
  - Bench test charges
- B Other Revenue-Sewer includes:
  - Wastewater service line inspection fees
- C Gain/Loss on Sale of Assets
- D Miscellaneous Revenue includes:
  - Administration charges
  - Charges for damage and repair to system:
    - Parts and labor used
    - Equipment charges

# **OKEECHOBEE UTILITY AUTHORITY**

AGENDA ITEM NO. 16

NOVEMBER 21, 2023

## **SALARY ANALYSIS & BENEFITS SURVEY – EVERGREEN SOLUTION**

On Thursday October 26<sup>th</sup>, OUA's project team had a conference call with Jeff Ling (President - Evergreen Solution LLC) and Kelly Tucker (Vice President of Marketing) to discuss:

- The age of Peer Review data
- Proposed cost of \$5,000 to update Peer Review data.

The issue of comparative Peer Review data arose when it came to OUA Project Team knowledge that the comparative data, received early September, did not include anticipated wage adjustment for Governmental entity whose financial year and salary increase takes effect October 1.

Given the apparent impact of not utilizing updated salaries and benefits to compare OUA's position in the market, Evergreen initially proposed an additional cost of \$5,000 for their team to revisit the market and update salary and benefit datasheets.

However, during the meeting on October 26<sup>th</sup>, Jeff Ling, advised that Evergreen will waive the proposed cost to update the Peer Review data and undertake the exercise at no additional cost to the Authority.

As a result of the added work, Evergreen subsequently advised that a revised draft will be available for OUA's project team review between end November to early December.

**OKEECHOBEE UTILITY AUTHORITY**

AGENDA ITEM NO. 17

NOVEMBER 21, 2023

**STATE ROAD 78W 24-INCH WATER MAIN STATE PROJECT**

The Okeechobee Utility Authority publicly advertised RFP/RFQ for the SR78 Water Main Improvements project and received proposals on November 2, 2023. The OUA selection committee comprising of OUA Board member Harry Moldenhauer, Jamie Mullis (Operations Director) and John Hayford (Executive Director) met to discuss the proposals.

Of biggest concern to all members was the timeline to complete the project for the OUA to try and meet the imposed FDOT timeline (July 2024) for construction of their project. It was the consensus of the committee that the FDOT schedule was not possible. The earliest completion date from the submittals was November 2024.

The OUA received submittals from three engineering firms:

- Kimley-Horn
- CHA Consulting
- Holts Consulting Engineers

Included for your review is the Engineers’ submittal, the RFP/RFQ and a sample engineering evaluation card.

The evaluation committee met on Wednesday, November 8<sup>th</sup> to review the proposals, to discuss the merits of each proposal and to prepare the committee ranking as shown below.

**State Road 78W 24-Inch Water Main State Project  
Engineering RFP Evaluation**

	HM	JM	JH
Kimely-Horn and Associates, Inc.	67	55	47
CHA Consulting, Inc.	66	58	51
Holts Consulting Engineers, Inc.	68	62	56

As noted above, Holts Consulting Engineers, Inc. scored the highest evaluation on all three score cards. It is the committee’s recommendation that HCE be considered as the engineer for this project.

The OUA Board after their review, will need to prepare a final ranking of the submittals, and if so inclined, direct staff to negotiate a scope of work and fee schedule starting with the number one ranked firm.



**Okeechobee Utility Authority  
Engineering Services  
SR 78W Water Main Improvements**

**Request for Qualifications/Proposals**

---

**PART 1**

**1.1 PURPOSE**

The Okeechobee Utility Authority is requesting respondents to submit their qualifications and proposals to provide professional engineering and technical services with regards to the preparation and submittal of a Preliminary Engineering/Feasibility Report providing for water utility system improvements to the State Road 78W service area. The completion of the report will lead to design, permitting and construction services for a water utility system improvement project. Each RFP, based upon the content submitted, will be evaluated with each proposal scored and ranked.

Ultimately, the OUA will select the engineer/consultant who most closely satisfies, in the opinion of the OUA, the needs of the OUA towards the requirements of this project.

**1.2 ISSUING OFFICE**

Okeechobee Utility Authority  
100 SW 5<sup>th</sup> Avenue  
Okeechobee, Florida 34974-4221

863.763.9460 (Tel)  
863.763.9036 (Fax)

**1.3 INVITATION TO PROPOSE**

The Okeechobee Utility Authority (OUA) is soliciting proposals from responders to provide professional engineering services or related professional services for the above referenced project. The project is addressed in general and as outlined in the Scope of Work.

**1.4 CONTRACT AWARDS**

Okeechobee Utility Authority anticipates entering into a contract with the respondent who submits the proposal judged by the OUA Evaluation committee or the OUA Board to be the most advantageous to the OUA. The OUA anticipates

awarding a single contract to the respondent selected and approved by the full OUA Board.

The respondent understands that this Request does not constitute an agreement or a contract with the OUA. An official contract or agreement is not binding until reviewed and accepted by the OUA Board and executed by all parties. The OUA reserves the right to reject all proposals, to waive any informality and to solicit and advertise for other proposals.

## **1.5 DEVELOPMENT COSTS**

Neither the OUA nor their representatives shall be liable for any expenses incurred in connection with the preparation of a response to this request. Respondents should prepare their submittals simply and economically, providing a straightforward and concise description of the respondent's ability to meet the requirements of the request.

## **1.6 INQUIRIES**

The OUA will not respond to questions posed within five calendar days of RFQ/RFP bid submittal. Only questions posed in writing and answered by the formal written addenda process will be binding. Oral and or other interpretations or clarifications will be without legal effect. Respondents may submit written inquires for interpretations of this request to:

Okeechobee Utility Authority  
Attn: John Hayford, P.E.  
100 SW 5<sup>th</sup> Avenue  
Okeechobee, Florida 34974-4221

[jhayford@ouafl.com](mailto:jhayford@ouafl.com)

863-763-9460 (Tel)  
863-763-9036 (Fax)

## **1.7 TIMETABLES**

The OUA and respondents shall adhere to the following schedule in all actions concerning this request:

- A. On October 10, 2023, OUA publicly releases this RFP.
- B. From October 10, 2023 to October 27, 2023, the OUA will receive and answer all inquiries received by general mail or e-mail.

- C. The OUA shall receive proposals up to 3:00 PM on November 2, 2023, at which time the proposals will be tabulated, opened and reviewed for compliance with the requirements listed in the RFP submittal.
- D. The OUA will review the proposals in a timely manner. The proposals shall be discussed during the OUA staff/committee review meeting tentatively scheduled for 11:00 A.M., November 8, 2023. The staff/committee will evaluate and produce a preliminary ranking of the proposals.
- E. The OUA staff/committee will deliver or make available to the OUA Board members a copy of each submittal and the staff/committee review evaluation.
- F. The OUA Board will review the staff/committee evaluations/ranking and publicly discuss the submittals at the OUA Board meeting, tentatively scheduled to begin at 9:30 A.M., Tuesday, November 21, 2023.
- G. The OUA Board may elect to postpone the award decision and to request presentations from the highest ranked firms. If so, the firms will be notified of the request and a date for the presentations will be selected by the OUA Board.
- H. If a presentation is not required, then, based upon the data provided and discussions, the OUA Board will determine the final ranking of the RFPs submitted. The OUA will notify all respondent(s) of the results of the ranking and review process.
- I. Upon approval of the final ranking, the highest ranked firm will enter into negotiations for a final scope of work and fee schedule. Upon successful negotiations, a contract will be prepared for review and execution by all parties. If negotiations are unsuccessful, the OUA will move on to the next highest ranked firm.

## **1.8 DELAYS**

The OUA may delay scheduled due dates if it is to the advantage of the OUA to do so. The OUA will notify respondents of all changes in the scheduled due dates by written addenda.

## **1.9 QUALIFICATION SUBMISSION AND WITHDRAWAL**

The OUA will receive proposals at the issuing office address set forth in Paragraph 1.2.

To facilitate processing, please mark the outside of the envelope in the lower left-hand corner as follows: **Engineering Services for SR 78W Water Main Improvements**. The outside of the envelope shall also include the Respondent's name and return address in the upper left-hand corner.

Respondents shall submit ten (10) copies of the proposal in a sealed, opaque envelope marked as noted above. The respondent may submit the proposals by U.S. mail, express delivery service or deliver in person.

### **THE OUA MUST RECEIVE THE PROPOSAL BY THE TIME AND DATE SPECIFIED IN SECTION 1.7**

Due to the irregularity of delivery services, the OUA cautions respondents to assure actual delivery of proposals to the issuing office prior to the deadline set forth above.

Respondents may withdraw their submissions by notifying the OUA in writing at any time prior to the opening time and date specified. Respondents may withdraw their submissions in person or via an authorized representative. Respondents and authorized representatives must provide a letter of withdrawal, picture identification, and proof of authorization (in the case of authorized representatives.) Proposals, once opened, become the property of the OUA and will not be returned to the respondent. Opened proposals become "public records" and are subject to the provisions of the Florida Public Records Law. As such they are subject to public disclosure in accordance with Chapter 119, Florida Statutes.

## **1.10 ADDENDA**

If revisions become necessary, the OUA will provide written addenda to all respondents who receive this Request and have identified themselves to the OUA as having received this RFQ/RFP.

## **1.11 EQUAL OPPORTUNITY**

The OUA recognizes fair and open competition as a basic tenet of the public procurement process and encourages participation by any and all qualified firms or individuals including those participating as minority and women business enterprises.

## **1.12 INSURANCE**

The respondent, if awarded a contract, shall maintain insurance coverage reflecting the minimum amounts and conditions as required by the OUA.

## **PART II THE PROJECT**

### **2.1 SCOPE OF WORK**

#### **A. INTRODUCTION**

This RFQ/RFP process is to assist the OUA in selecting a qualified professional engineering services firm for the above referenced project. The RFQ/RFP submittal will include firm specific information, such as, team members, location, past project experience, current project capabilities, project approach and other pertinent information in order to choose the best qualified firm for project success.

#### **B. THE PROJECT**

The selected engineering firm (see Paragraph 1.7 I) will be tasked providing, at a minimum, the following project elements:

- Preliminary Engineering/Feasibility Report or Facilities Plan to serve the project area;
- Provide services as needed to submit and obtain SRF or other such funding to supplement funding for the project;
- Evaluate current water services and expanded service area with proposed improvements;
- Project surveying, from right-of-way for the length of the project has already been accomplished and will be provided;
- Selected firm will provide design and permitting services for the development of project plans and specifications;
- Provide bidding & construction (CEI) capabilities along with certification and project closeout services.

The project requirements are to review existing water system infrastructure in the project area, identify potential connections and associated flows, alternatives analysis to meet proposed expansion, associated preliminary cost estimates of all alternatives proposed and a ranking of the alternatives.

The project area includes the existing SR 78W corridor and the community of Buckhead Ridge. Metered monthly flow records will be provided by the OUA. There are two pending developments that shall also be considered in the analysis: a resort development at the former Okee-Tantie Campgrounds

and a 1,400 unit development currently being considered next to the existing Buckhead Ridge (BHR) community.

### C. PROJECT AREA

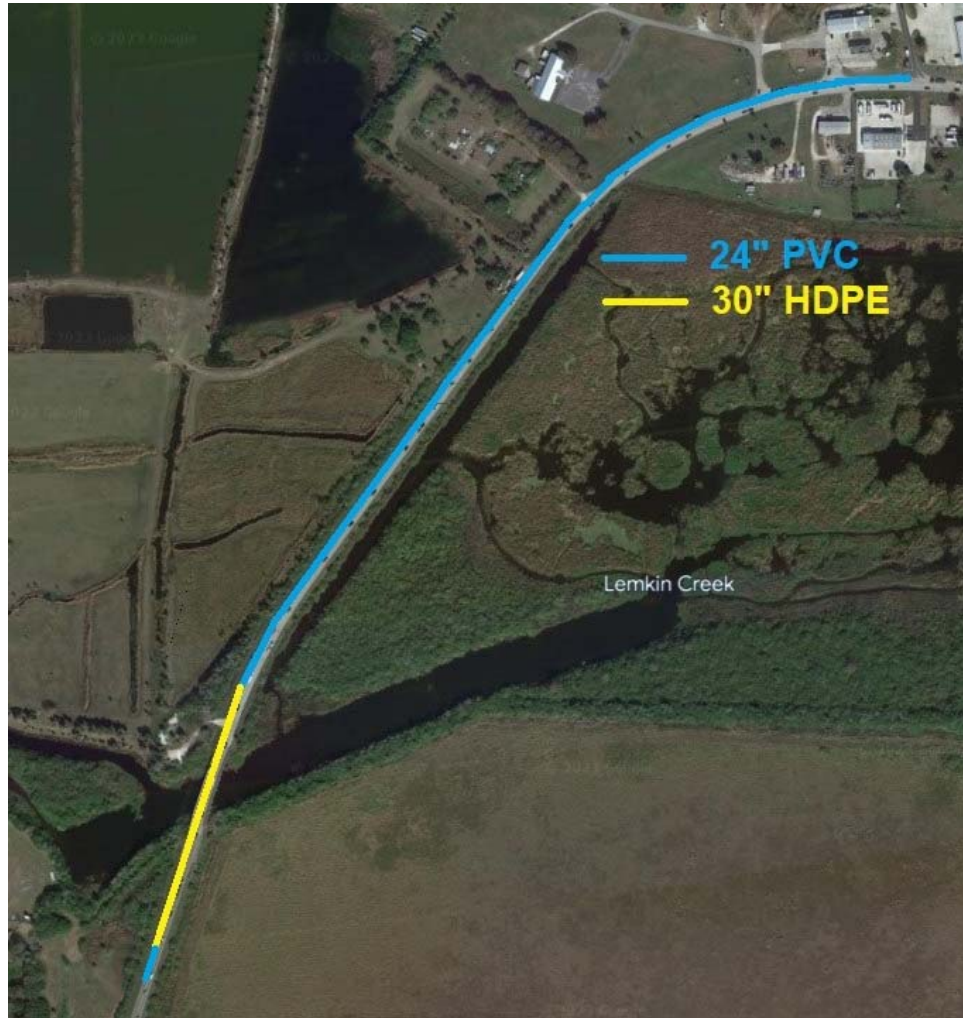

The pipe diameter designations are for illustrative purposes only. Actual pipe type and diameters will be determined by the selected consultant based upon the alternatives/hydraulic analysis.

Currently, the OUA has two water mains serving the Okee-Tantie/BHR service area: an 8-inch ductile iron piping system on the lake side of SR 78 roadway while an older 6-inch cast iron piping system is along the other side of SR 78W. While a HDD is currently proposed to cross Lemkin Creek, the final design will be selected by the consultant. At the conclusion of the installation of the new water main, removal of the two existing mains is proposed.

## **PART III INSTRUCTION FOR PREPARING RFQ/RFP SUBMISSIONS**

### **3.1 RULES FOR SUBMISSIONS**

The submittal must name all persons or entities interested in or participating in the submission. The proposal must declare that it is made without collusion with any other person or entity submitting a proposal.

#### **SUBMISSION FORMAT**

##### **A. Letter of Transmittal**

This letter will summarize in a brief and concise statement the Respondent's proposal. An official authorized to negotiate for the respondent must sign the letter of transmittal. The letter strive to not exceed five (5) pages in length. All subcontractors and percentage of work shall be clearly identified.

##### **B. Location and Personnel**

The location of the Respondent's office(s) that will be responsible for the actual production of the work shall be identified. The key personnel in that office(s) who will be responsible for the completion of the work must also be identified.

##### **C. Project References**

This section may be submitted by the respondent to aid in the review of the respondent's capabilities. If submitted, the submission must include a list of no more than five (5) representative reports/studies/projects of a similar type that have been completed within the last ten (10) years. For each report/study/project, identify the responsible office(s) and key individual(s) that completed these submittals. For review purposes, the list should include at a minimum, the following items:

1. A brief description of the submittal including all costs and time allowed for the proposed work.
2. List any work directives, change orders, etc. that were issued and reason for same.
3. Total final cost and time.
4. Owner of the project.

5. The name and telephone number of a contact person for the Owner.
6. The dates the project was initiated and completed.

Similar type reports/studies/projects shall mean the key elements of the work items identified in this RFP Scope of Work or in the Respondents Scope of Work submittal.

**D. Proposed Schedule of Work, Investigations, Milestones and Results**

Provide a proposed Table of Contents with brief description of the work intended, project approach and knowledge of the project scope. The proposed work should meet or exceed the guidelines proposed within this RFP.

**E. Other Information**

This section can include key staff members who will actually oversee, assist in or conduct the work (these members should be clearly identified as to their expected work assignments), workload projections, and any other information the respondent wishes to include for consideration.

**PART IV EVALUATION OF SUBMISSIONS**

**4.1 EVALUATION METHOD AND CRITERIA**

**A. General**

The OUA shall be the sole judge of its' own best interest, the submittal, and the resulting negotiated agreement. In all instances the OUA's decisions will be final.

The OUA's evaluation criteria will include, but not be limited to, consideration of the following:

1. Familiarity with the Okeechobee Utility Authority's Standards and Specifications.
2. Experience with similar type reports/studies/projects.
3. Key personnel's experience with similar projects and their availability to work on this project.
4. Knowledge of project scope and intent.



5. References from other related projects.
6. Project approach.

**B. Selection**

The OUA shall review, discuss and evaluate the written proposals submitted for proposed project. The OUA may choose to conduct interviews and schedule presentations prior to making a final decision. The OUA Board will make the final selection.

**C. Negotiations**

The OUA Board will select and rank the submittals based upon the qualifications and certifications listed in the submittals. Staff will negotiate with the top ranked firm to clearly define a scope of work, project work schedule and a compensation package. Should these negotiations fail, then the negotiations with this firm will be terminated and staff will begin discussions with the next firm on the list.

As stated in Paragraph 1.4 above, the OUA reserves the right to reject any or all proposals, and to waive any irregularities.

**OKEECHOBEE UTILITY AUTHORITY**  
**SR78W WATER MAIN IMPROVEMENTS**  
**ENGINEERING RFP EVALUATION**

WORSE ←————→ BETTER

		1	2	3	4	5
	<b>Knowledge of OUA Infrastructure by Submitter</b>					
1.	Understanding of general information, background of OUA and service area					
2.	Presentation of information obtained by Firm with respect to water main design, permitting & construction					
3.	Presentation of information obtained by Firm on existing OUA facilities					
	<b>Review of Submitting Firm Qualifications</b>					
4.	Review of Firms qualifications with respect to past design and utility system experience					
5.	Review of Firms qualifications with respect to surveying					
6.	Review of Firms qualifications with respect to water distribution/transmission systems					
7.	Review of Firms overall qualifications with respect to professional design services					
8.	Review of Firms overall adequacy and experience of personnel and services					
9.	Review of Firms overall projected work load and ability to complete the project in a timely fashion					
10.	Review of Firms past record, either with OUA or referrals/references					
11.	Review of Firms past experiences with FDEP, FDOT, SFWMD or other regulatory agencies					
	<b>Intangibles</b>					
12.	Overall Presentation: skill/knowledge/expertise					
13.	Overall Qualifications: capabilities & personnel					
14.	Overall Experience: company & personnel					
	<b>TOTAL</b>					

Number of Items reviewed above: \_\_\_\_\_

Total Points: \_\_\_\_\_

**Firm:** \_\_\_\_\_.

—

Average Score: \_\_\_\_\_

# **OKEECHOBEE UTILITY AUTHORITY**

AGENDA ITEM NO. 18

NOVEMBER 21, 2023

## **WWTF FOR NE GLADES COUNTY – FEASIBILITY REPORT**

Please find attached a scope of work and fee schedule proposed to complete a feasibility report for the proposed NE Glades County WWTF. At this time, the FDEP Grant Portal request to fund the design and construction of this facility is still pending.

CHA Consulting was asked to prepare this scope of work to support any possible questions asked by FDEP. To complete the report, CHA is reporting that it could take up to 132 calendar days ( $\pm 4\frac{1}{2}$  months), well beyond the expected time frame to award a grant if this project is approved.

While this document can be used to support a preliminary design report, it exceeds what OUA staff was looking for in support of any answers to questions posed during the grant submittal process. A copy of this document has been supplied to Lakefront Estates for their review. At the time of drafting this agenda item, Lakefront has not responded with any questions, comments or concerns with the scope of work and additionally, has not offered any financial support towards the fee schedule. This statement is not saying that they won't have questions and do not intend on financial support.

OUA staff is providing this agenda item and document for informational purposes only and does not recommend any action at this time.



November 8, 2023  
235-000.BD

Mr. John Hayford, P.E.  
Okeechobee Utility Authority  
100 SW 5th Avenue  
Okeechobee, FL 34974-4221

Dear Mr. Hayford:

Reference: Proposal for Engineering Services  
Wastewater Treatment Facility for Northeast Glades County- Feasibility Report  
Task Order No. 14

In accordance with the OUA's request, we are pleased to submit this proposal for providing engineering services for the Wastewater Treatment Facility for Northeast Glades County project. This proposal includes:

1. Engineering Services to complete a Feasibility Report for the Wastewater Treatment Facility for Northeast Glades County.

The proposed scope of work for this project is attached as Task Order No. 14. Our proposed lump sum fee for the professional engineering services is \$80,700. A breakdown of the fee calculation is attached to the Task Order.

CHA Consulting looks forward to providing professional engineering services to the Okeechobee Utility Authority wastewater treatment feasibility project. If you have any questions or require additional information pertaining to the enclosed Task Order or the project in general, please do not hesitate to contact me.

Sincerely,

A handwritten signature in blue ink that reads 'Douglas Hammann'.

Douglas K. Hammann, P.E.  
Project Team Leader

Encl.

**TASK ORDER NUMBER 14**

**ENGINEERING SERVICES FOR  
WASTEWATER TREATMENT FACILITY FOR NORTHEAST GLADES COUNTY  
AREA  
FEASIBILITY REPORT**

**ARTICLE 1 – SCOPE OF SERVICES**

**Introduction**

The Okeechobee Utility Authority (OUA) requested CHA Consulting, Inc. (ENGINEER) to provide a proposal to perform engineering services to complete a feasibility report for the Wastewater Treatment Facility for Northeast Glades County Area . To facilitate planning and design criteria recommendations, a feasibility report of the following preliminary outline is needed:

**A. Executive Summary**

- Overview of the feasibility study with focus on report organization, study results and overall recommendations.
- Address summary of costs - both capital and O&M.
- Present next steps for moving forward.
- General descriptive graphics and tables.

**B. Introduction**

- Introduce overall project goal and intent of the feasibility study.
- Review the report presentation.

**C. Proposed Wastewater Flow Demands**

- Determine population of service area and future population projections.
- Current and future wastewater flow projections.
- Review OUA criteria for level of service/ equivalent residential connections to determine gallons per day per capita.

**D. Influent/Effluent Design Parameters**

- Typical Domestic wastewater influent constituents and typical concentrations.
- Review of Lake Okeechobee Basin Management Action Plan (BMAP).
- Review of State domestic wastewater treatment parameter requirements.
- Effluent Disposal Parameters.

**E. Design Criteria**

- Effluent water quality and disposal.
- Biosolids management and disposal.

- Current regulatory requirements
- Future regulatory issues.
- Potential emerging contaminants issues.
- Primary and emergency power requirements.
- Building design criteria.
- Plant capacity.
- Reuse service feasibility.

#### **F. Preliminary Consideration of Wastewater Treatment Technologies**

- Preliminary consideration of three treatment technologies to achieve the required effluent parameters. Wastewater treatment technologies may include oxidation ditch, sequencing batch reactors, and MBRs.
- Preliminary consideration of three disposal methods for treated wastewater to achieve discharge permit requirements. Disposal Methods may include spray irrigation, rapid infiltration basins (RIBs), and deep well injection.
- Provide summary of each wastewater treatment technology considered for treatment.
- Provide cost comparison and recommendation of wastewater treatment technology to consider for final design report phase.

#### **G. Identification of Preliminary Facility and Process Components**

- Prepare a preliminary facility process flow diagram.
- Identify all preliminary major process components with tabulated component preliminary design criteria.
- Prepare preliminary site plan of the proposed improvements. Include phasing options.
- Site plan will consider the estimated size of all proposed structures, setbacks, and other site related criteria.

#### **H. Opinion of Probable Cost Opinion**

- Prepare a preliminary opinion of probable construction cost of recommended facility.
- Level of cost opinion shall be AACE Class 4. Class 4 end usage is study or feasibility level, with an expected accuracy range of low end -15% to -30% and high end +20% to +50%.
- Prepare a preliminary opinion of O&M cost of recommended facility.
- This evaluation will be prepared as a present worth analysis, with a useful life threshold of 20 to 30 years.

#### **I. Regulatory Permit Requirements**

- Identify applicable regulatory requirements and permits.

## **J. Project Phasing Considerations**

- Determine project phasing options and requirements.
- Phasing based on financial, capacity and constructability constraints or other considerations of importance to the OUA.
- Phasing can be developed and based on the project drivers. Project Schedule
- Prepare overall project master schedule.
- Schedule shall include all design, permitting, bidding/award, construction, and commissioning/startup/closeout phases.
- Include impacts of all identified phasing requirements.

## **K. Recommendations**

- Base a final recommendation on the information determined or gathered throughout the process of completing this feasibility study.
- Define basis of the recommendations determined. Such as importance factors.

## **L. Attachments**

- Miscellaneous report attachments, such as: drawings, sketches, other reports, etc.

The tasks associated with each of these services are presented below:

## **PROJECT SERVICES**

### **Task 1 - Project Administration/Management**

Perform general project coordination and management activities, including general administrative activities for this authorization, as well as specific coordination activities with OUA necessary for gathering information to complete the Feasibility Plan. Other duties include invoicing, monthly status reports and monthly updates to OUA via phone conference, and project scheduling. The invoices will include the percent complete for each task to advise and highlight the overall progress of the tasks, as well as identify completed, on-going and pending activities.

### **Task 2 - Data Gathering, Preliminary Coordination Activities and Initial Meetings**

ENGINEER shall coordinate with OUA and assist with obtaining the necessary preliminary information required to prepare the Feasibility report including but not limited to:

1. Existing Development Agreements.
2. Buckhead Ridge population information.
3. Utility customer information for service area.
4. Other data as applicable to completion of this task order.

ENGINEER shall schedule and complete a project kickoff meeting workshop with ENGINEER's project team and OUA Staff. This meeting shall formalize project goals and concerns; establish

project management; set project schedule and allow input from OUA and project team to be addressed and finalized at onset of project.

### **Task 3 – Feasibility Report Preparation**

This task focuses on evaluation of data, preparation, and completion of the Wastewater Treatment Facility for Northeast Glades County Area Feasibility Report. All engineering, administrative, financial, cost estimating, graphics and other related labor and staffing shall be provided to complete the report per the outline and contents of the various sections as presented herein above. The primary objective of this Feasibility Report is to provide the OUA support for funding applications. The second objective is to provide a preliminary overview of the anticipated requirements for a proposed WWTF in NE Glades County. It is intended that the information provided in the Feasibility Report will become the starting point to prepare a future Basis of Design Report (BODR) for the WWTF, if the project moves into design and permitting phases.

### **Task 4 –Periodic Project Meetings**

ENGINEER will schedule meetings with OUA staff at various times during the preparation of the Feasibility report. The purpose of these meetings will be to address the following:

1. Review status of project and work completed prior to meeting.
2. Review work projected to be completed prior to next meeting.
3. Review status of project RFI's.
4. Review general specific concerns or questions that have potential to impact the project.
5. Project schedule status review.

A total of Two (2) meetings are anticipated for this project. Two (2) meetings will be conducted virtually. One will be the project Kickoff Meeting. **Task 5 – Submit and Review (Quality Control)**

The ENGINEER will make the following submittals at various completion levels of this project for the purpose of OUA's review and comment for coordination and quality control. A review meeting will be requested following each submittal to discuss and receive comments from OUA. The OUA's comments shall be incorporated into revisions prior to the next control submittal. Quality control submittals for this project are anticipated at the following completion levels:

1. Draft Report (75% completion level).
2. Draft Report (100% completion level).

The ENGINEER will incorporate the agreed-upon revisions made by the OUA.

A total of two (2) meeting(s) with the OUA is the level of effort for this Task.

### **Task 6 – Final Submittal Preparation, Reproduction and Report Distribution**

ENGINEER will finalize the report based upon review comments provided at the 100% submittal review meeting with OUA staff. After the submittal is finalized, ENGINEER shall reproduce and distribute the final report.



## **ARTICLE 2 – DATA OR ASSISTANCE TO BE PROVIDED BY OUA**

- A. Provide information and data as requested.
- B. Provide assistance with obtaining information from the proposed Lake Front Estates project, Developer.
- C. Provide assistance with regulatory agencies and attend meetings with agencies when requested.
- D. Attendance at project meetings.
- E. Provide general project review, where required.

## **ARTICLE 3 - TIME OF COMPLETION**

Attachment 1 provides the preliminary project schedule based on days from receipt of the Notice of Commencement. The proposed project schedule may be modified to meet OUA's funding application submittal schedules, as needed.

## **ARTICLE 4 - PROJECT DELIVERABLES**

Project deliverables shall be in accordance with Attachment .

## **ARTICLE 5 - PAYMENT AND COMPENSATION**

As consideration for providing the services enumerated, the OUA shall pay the ENGINEER fees as described below:

- A. For the services enumerated in Tasks 1 through 6, the lump sum fee of **\$80,700.00**.

The above fees have been determined in accordance with the scope of work breakdowns attached as Attachments 3.

This proposal does not include the provision of the following items:

- Any expert witness or testimony services.
- Design of wastewater facility improvements.
- Preparation of bid specifications, drawings, or contract documents for recommended facilities.
- Preparation of permit submittal applications.
- Provision of any pilot testing.
- Provision of any hydrogeological reports for deep well injection analysis.
- Provision of and/or payment of any laboratory analysis fees.
- Preparation or provision of utility rate analysis to support recommendations of the

feasibility study.

- Services not specifically indicated in this Task Order.

**ARTICLE 6 - AUTHORIZATION**

In WITNESS WHEREOF, the parties herewith subscribe the same in duplicate.

CHA CONSULTING, INC.

OKEECHOBEE UTILITY AUTHORITY

By: \_\_\_\_\_  
Douglas K. Hammann, P.E.  
Project Team Leader

By: \_\_\_\_\_  
Tommy Clay  
Chairman

Date: \_\_\_\_\_

Date: \_\_\_\_\_

By: \_\_\_\_\_  
John F. Hayford, P.E.  
Executive Director

Date: \_\_\_\_\_

V:\Projects\CSFL122\Y\Documents\Okeechobee\BD\Task Orders\Task Order No. 14 - BuckHead Ridge WWTP Feasibility Study\Task Order\TO 14.docx

(Remainder of this page left blank intentionally.)

**ATTACHMENT 1**

**WASTEWATERTREATMENT FACILITY FOR NORTHEAST GLADES COUNTY  
AREA  
FEASIBILITY REPORT  
TASK ORDER NUMBER 14**

**Preliminary Project Schedule**

<b><u>Activity</u></b>	<b><u>Duration (Days)</u></b>	<b><u>Cumulative Time (Days)</u></b>
Authorization to Proceed	0	0
Kickoff Meeting and Data Collection	14	14
Submit Draft Report (75% Completion Level)	60	74
Receive OUA Review Comments	7	81
Submit Draft Report (100% Completion Level)	30	111
Receive OUA Review Comments	7	118
Submit Final Report	7	125
Project Closeout	7	132

Detailed schedule will be provided upon receipt of authorization to proceed and will include specific submittal dates.

(Remainder of page left blank intentionally.)

**ATTACHMENT 2**

**WASTEWATERTREATMENT FACILITY FOR NORTHEAST GLADES COUNTY  
AREA  
FEASIBILITY REPORT  
TASK ORDER NUMBER 14**

**List of Project Deliverables**

**REPORT**

- A. Draft Report (75% Completion Level)
  - < One (1) electronic (PDF) Report
  
- B. Draft Report (100% Completion Level)
  - < One (1) electronic (PDF) Report
  
- C. FINAL Report
  - < One (1) electronic (PDF) Report
  - < Two (2) Signed and Sealed Reports for OUA's official records.

(Remainder of page left blank intentionally.)

# OKEECHOBEE UTILITY AUTHORITY

## WASTEWATER TREATMENT FACILITY FOR NORTHEAST GLADES COUNTY AREA FEASIBILITY REPORT TASK ORDER NO. 14 ATTACHMENT 3

I. LABOR

DATE: November 8, 2023

	TASK DESCRIPTION	PERSONNEL										
		Principal	Engineer 8	Engineer 5	Engineer 4	Engineer 3	Engineer 2	Technician 4	Technician 3	Technician 2	Resident/ Local Assistance	Administrative
D1	Project Administration/Management	5	14	28	0			0				5
D2	Data Gathering and Preliminary Matters	5	10	20	40			0				15
D3	Feasibility Report Preparation	10	35	50	80			24				35
D4	Periodic Project Meetings	5	0	5	0			0				0
D5	Submit and Review (Quality Control)	5	15	28	32			8				8
D6	Final Submittal Preparation, Reproduction and Report Distribution	4	8	8	16			8				8
D7	Not Used											
D8	Not Used											
D9	Not Used											
D10	Not Used											
D11	Not Used											
D12	Not Used											
Total Hours		34	82	139	168	0	0	40	0	0	0	71
Rate		\$233.00	\$213.00	\$155.00	\$130.00	\$98.00	\$92.00	\$130.00	\$109.00	\$82.00	\$98.00	\$82.00
Sub-Total Labor		\$7,922.00	\$17,466.00	\$21,545.00	\$21,840.00	\$0.00	\$0.00	\$5,200.00	\$0.00	\$0.00	\$0.00	\$5,822.00
<b>TOTAL LABOR</b>											<b>\$79,795.00</b>	

II. REIMBURSABLE EXPENSES

EXPENSE ITEM	EXPENSE TYPE	UNIT	No. OF UNITS	COST PER UNIT	TOTAL COST
1	REPRODUCTION				
	Half Size Drawings (11" x 17")	EA	0	\$1.50	\$0.00
	Full Size Drawings (22" x 34")	EA	0	\$3.30	\$0.00
	Specification Booklets	EA	0	\$0.00	\$0.00
	Prepare Report Document	EA	3	\$50.00	\$150.00
2	PHOTOCOPIES	EA	50	\$0.20	\$10.00
3	PLOTTING				
	22 X 34 (SET UP )	EA	3	\$15.00	\$45.00
	11 X 17 (SET UP)	EA	3	\$3.00	\$9.00
4	TRAVEL				
	MILEAGE	MILE	950	\$0.665	\$631.75
	TOLLS	TRIP	4	\$5.60	\$22.40
	HOTEL/MEALS	DAY	0	\$155.00	\$0.00
5	SUBCONSULTANTS				
	SURVEY	LS	0	\$0.00	\$0.00
	ELECTRICAL	LS	0	\$0.00	\$0.00
	STRUCTURAL	LS	0	\$0.00	\$0.00
	GEOTECHNICAL	LS	0	\$0.00	\$0.00
	HYDROGEOLOGY	LS	0	\$0.00	\$0.00
		LS	0	\$0.00	\$0.00
<b>TOTAL EXPENSES</b>					<b>\$868.15</b>

<b>GRAND TOTAL</b>	<b>\$80,663.15</b>
<b>USE</b>	<b>\$80,700.00</b>

# OKEECHOBEE UTILITY AUTHORITY

AGENDA ITEM NO. 19

NOVEMBER 21, 2023

## SECURITY CAMERA SWTP

OUA staff contacted Advanced Alarm, Group One Safety & Security, AME Straight Technologies, Inc. and Seagull Electronics concerning the need for security cameras in and around several OUA facilities. After several telephone contacts and emails, Advanced Alarm contacted the OUA and stated for several reasons they could not be of service to the OUA. Similar telephone and email contacts had been sent to the others.

The OUA received various quotes from the two of the three remaining companies (Group One & AME Technologies). The quote from Group One contained Network Video Recorders, monitor, battery back-up and installation. Their proposal for the water plant had eight cameras. An additional camera could be placed for approximately \$1,545.00. The quote from AME was not very detailed and additional information was requested. The additional information said their quote contained two cameras both of which would be wired to the base terminal.

Please see attached proposals.

Group One	\$10,280.00
AME Technologies	\$10,409.00 to \$13,909.00 depending on camera quality

OUA staff recommends approval of the surface water treatment plant for the initial quote of \$10,280 plus the installation of four additional cameras at an estimated price of \$6,180.00, bringing the entire quote to \$16,460.00.

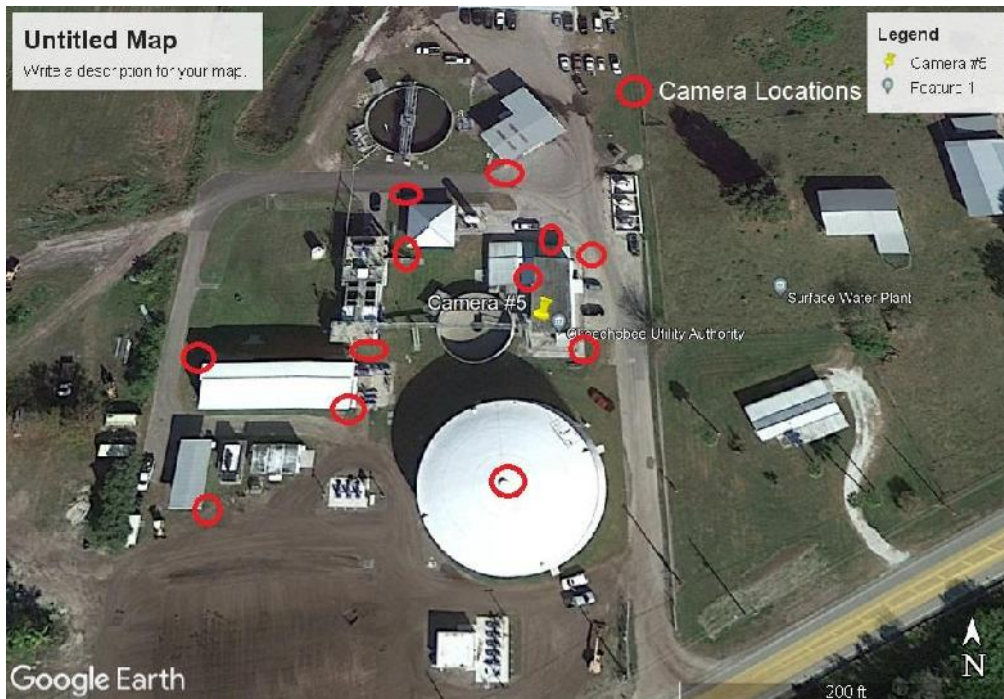



July 12, 2023

Okeechobee Utility Authority  
100 S.W. 5<sup>th</sup> Avenue  
Okeechobee, FL 34974

Attention: John Hayford, P.E.

### **SURFACE WATER TREATMENT PLANT SURVEILLANCE SYSTEM DESCRIPTION**

Group One Safety & Security proposes to wire for and install the following new equipment at the location described above:

- 8 Eight HIKVision, domed, network cameras, model # DS-2CD2347 G2 with a 2.8 mm or 4 mm lens and 4 mega pixel resolution. This camera is designed to provide very good images in low light conditions.
- 8 Eight HIKVision HXWML and PC140 mounting brackets
- 1 One HIKVision, 16-camera Network Video Recorder with 12 terabyte hard drive, model # HX-N7616QP-12T. When the hard drive is full, the newest video images will record over the oldest images so that you will have a continuous video record when you need it. You can save specific video events with a common flash drive and view them on another computer or provide them to the police. You will be able to view the cameras live or view recordings with the video monitor. This system has internet capability and can be viewed from your computer or smart phone. **High speed internet will be necessary at this location to allow the video to be viewed remotely.**
- 1 One WBox 19" color monitor, model # OE-19VGHDMIZ
- 1 One WBox 800va battery back-up system, model # OE-825V12VRD



July 12, 2023

Okeechobee Utility Authority  
100 S.W. 5<sup>th</sup> Avenue  
Okeechobee, FL 34974

**SURFACE WATER TREATMENT PLANT  
SURVEILLANCE SYSTEM SUMMARY**

1. Group One Safety & Security agrees to supply and install the following new equipment at the location described above:
  - 8 Eight HIKVision, domed, network cameras, model # DS-2CD2347 G2 with a 2.8 mm or 4 mm lens and 4 mega pixel resolution.
  - 8 Eight HIKVision HXWML and PC140 mounting brackets
  - 1 One HIKVision, 16-camera\* Network Video Recorder with 12 terabyte hard drive, model # HX-N7616QP-12T
  - 1 One WBox 800va battery back-up, model # OE-825V12VRD
  - 1 One WBox 19" color monitor, model # OE-19VGHEMIZ
2. Installation of this system will require the installation of adequate power and shelving at the desired location for the NVR, shelving and power are not included in the proposal.
3. The cameras in this proposal are to be mounted on the main office building of the Surface Water Treatment Plant. Camera locations will be influenced by our ability to pull wiring inside of the building to the desired camera locations and reasonable access to the desired camera locations.

SURVEILLANCE SYSTEM AS DESCRIBED ABOVE: \$10,280.00

Accepted by:

Date:

Estimated by: Rusty Corby

Date: 07/12/23

\* The 16-camera NVR is proposed here to allow you the ability to add cameras at a later date if desired and add them to the existing NVR.





July 12, 2023

Okeechobee Utility Authority  
100 S.W. 5<sup>th</sup> Avenue  
Okeechobee, FL 34974

### **SURFACE WATER TREATMENT PLANT SUGGESTED CAMERA LOCATIONS**

**Suggested camera locations would be to provide images of:**

1. The access road from S.R. 78
2. The East parking area of the main office building
3. The road roundabout N.E. of the main office building
4. The road to the N.W. towards the open treatment tank
5. At the S.W. corner of the building towards the large covered tank

The remaining three to be located to the West and South of the main office building directed to show images of your concern/interest

### **SURFACE WATER TREATMENT PLANT REMOTE CAMERA LOCATIONS**

Mr. Hayford, we discussed the installation of cameras in remote locations. We have the ability to transmit video signals from one building to the next, allowing us to install cameras on other buildings beside the main office building.

To install remote cameras, we will need a clear line of sight from the transmitter to the receiver and 110v power at the camera location. We will also need to be able to pull wire from the transmitter back to the NVR in the office building.

The installation cost may vary a bit depending upon the specifics of the installation but anticipated installation per camera would be:

\$1,545.00

DS-2CD2347G2-L(U)

4 MP ColorVu Fixed Turret Network Camera

## ColorVu



Hikvision ColorVu technology provides 24/7 vivid colorful images with F1.0 advanced lenses, high performance sensors and friendly lighting. F1.0 super-aperture collects more light to produce brighter images. Advanced sensor technology can vastly improve the utilization of available light. In zero-light scenarios, built-in, warm supplemental lighting works to guarantee colorful images.

- High quality imaging with 4 MP resolution
- Efficient H.265+ compression technology
- Clear imaging against strong back light due to 130 dB WDR technology
- Built-in microphone for real-time audio security(-U)
- Focusing on human and vehicle classification based on deep learning
- 24/7 colorful imaging



## ▪ Specification

Camera	
Image Sensor	1/1.8" Progressive Scan CMOS
Min. Illumination	0.0005 Lux @ (F1.0, AGC ON), 0 Lux with Light
Shutter Speed	1/3 s to 1/100,000 s
Slow Shutter	Yes
P/N	P/N
Wide Dynamic Range	130 dB
Angle Adjustment	Pan: 0° to 360°, tilt: 0° to 75°, rotate: 0° to 360°
Lens	
Depth of Focus	2.8 mm, 2.5 m to ∞ 4 mm, 3.5 m to ∞ 6 mm, 7.5 m to ∞
Lens Type & FOV	2.8 mm, horizontal FOV 109°, vertical FOV 55°, diagonal FOV 138° 4 mm, horizontal FOV 94°, vertical FOV 49°, diagonal FOV 113° 6 mm, horizontal FOV 57°, vertical FOV 32°, diagonal FOV 66°
Aperture	F1.0
Lens Mount	M16
DORI	
DORI	2.8 mm, D: 65 m, O: 21 m, R: 13 m, I: 6 m 4 mm, D: 72 m, O: 28 m, R: 14 m, I: 7 m 6 mm, D: 109 m, O: 43 m, R: 21 m, I: 10 m
Illuminator	
White Light Range	30 m
Smart Supplement Light	Yes
Video	
Max. Resolution	2688 × 1520
Main Stream	50Hz: 25 fps (2688 × 1520, 1920 × 1080, 1280 × 720) 60Hz: 30 fps (2688 × 1520, 1920 × 1080, 1280 × 720)
Sub Stream	50Hz: 25 fps (640 × 480, 640 × 360, 320 × 240) 60Hz: 30 fps (640 × 480, 640 × 360, 320 × 240)
Third Stream	50Hz: 25 fps (1280 × 720, 640 × 480, 640 × 360, 320 × 240) 60Hz: 30 fps (1280 × 720, 640 × 480, 640 × 360, 320 × 240)
Video Compression	Main stream: H.265/H.264/H.264+/H.265+ Sub-stream: H.265/H.264/MJPEG Third stream: H.265/H.264
Video Bit Rate	32 Kbps to 8 Mbps
H.264 Type	Baseline Profile/Main Profile/High Profile
H.265 Type	Main Profile
H.264+	Main Stream supports
H.265+	Main Stream supports
Bit Rate Control	CBR/VBR
Scalable Video Coding (SVC)	Yes
Region of Interest (ROI)	1 fixed region for each stream

<b>Audio</b>	
Environment Noise Filtering	-U: Yes
Audio Sampling Rate	-U: 8 kHz/16 kHz/32 kHz/44.1 kHz/48 kHz
Audio Compression	-U: G.711ulaw/G.711alaw/G.722.1/G.726/MP2L2/PCM/MP3
Audio Bit Rate	-U: 64Kbps(G.711ulaw/G.711alaw)/16Kbps(G.722.1)/16Kbps(G.726)/32-192Kbps(MP2L2)/ 8-320Kbps(MP3)
<b>Network</b>	
Simultaneous Live View	Up to 6 channels
API	ONVIF (PROFILE S, PROFILE G, PROFILE T), ISAPI, SDK
Protocols	TCP/IP, ICMP, HTTP, HTTPS, FTP, DHCP, DNS, DDNS, RTP, RTSP, NTP, UPnP, SMTP, IGMP, 802.1X, QoS, IPv6, UDP, Bonjour, SSL/TLS, PPPoE
User/Host	Up to 32 users. 3 user levels: administrator, operator and user
Security	Password protection, complicated password, HTTPS encryption, IP address filter, Security Audit Log, basic and digest authentication for HTTP/HTTPS, TLS 1.2, WSSE and digest authentication for ONVIF
Network Storage	MicroSD/SDHC/SDXC card (256 GB) local storage, and NAS(NFS, SMB/CIFS), auto network replenishment (ANR)
Client	iVMS-4200, Hik-Connect, Hik-Central
Web Browser	Plug-in required live view: IE 8+, Chrome 41.0-44, Firefox 30.0-51, Safari 8.0-11 Plug-in free live view: Chrome 57.0+, Firefox 52.0+
<b>Image</b>	
Day/Night Switch	Day, Night, Auto, Schedule
Image Enhancement	BLC, HLC, 3D DNR
Image Parameters Switch	Yes
Image Settings	Rotate mode, saturation, brightness, contrast, sharpness, gain, white balance adjustable by client software or web browser
<b>Interface</b>	
Built-in Microphone	-U: Yes
On-board Storage	Built-in micro SD/SDHC/SDXC slot, up to 256 GB
Hardware Reset	Yes
Communication Interface	1 RJ45 10M/100M self-adaptive Ethernet port
<b>Smart Feature-Set</b>	
Basic Event	Motion detection, video tampering alarm, exception (network disconnected, IP address conflict, illegal login, HDD full, HDD error), scene change detection
<b>Intelligent (Deep Learning Algorithm)</b>	
Face Capture	Yes
Premier Protection	Line crossing detection, intrusion detection, region entrance detection, region exiting detection
<b>General</b>	
Linkage Method	Upload to NAS/memory card, notify surveillance center, trigger record, trigger capture
Web Client Language	33 languages English, Russian, Estonian, Bulgarian, Hungarian, Greek, German, Italian, Czech, Slovak, French, Polish, Dutch, Portuguese, Spanish, Romanian, Danish, Swedish, Norwegian, Finnish, Croatian, Slovenian, Serbian, Turkish, Korean, Traditional Chinese, Thai, Vietnamese, Japanese, Latvian, Lithuanian, Portuguese (Brazil), Ukrainian

General Function	Anti-flicker, heartbeat, mirror, privacy masks, flash log, password reset via e-mail, pixel counter
Software Reset	Yes
Storage Conditions	-30 °C to 60 °C (-22 °F to 140 °F). Humidity 95% or less (non-condensing)
Startup and Operating Conditions	-30 °C to 60 °C (-22 °F to 140 °F). Humidity 95% or less (non-condensing)
Power Supply	12 VDC ± 25%, PoE: 802.3af, class 3
Power Consumption and Current	12 VDC, 0.55 A, max. 6.6 W PoE: (802.3af, 36 V to 57 V), 0.22 A to 0.13 A, max. 7.6 W
Power Interface	Ø5.5 mm coaxial power plug
Material	Aluminum alloy body, except for trim ring
Screw Material	SUS304
Camera Dimension	Ø138.3 × 125.2 mm (Ø5.4" × 4.9")
Package Dimension	170 × 170 × 150 mm (7" × 7" × 5.9")
Camera Weight	Approx. 820 g (1.8 lb.)
With Package Weight	Approx. 1137 g (2.5 lb.)
<b>Approval</b>	
Class	Class B
EMC	FCC SDoC (47 CFR Part 15, Subpart B); CE-EMC (EN 55032: 2015, EN 61000-3-2: 2014, EN 61000-3-3: 2013, EN 50130-4: 2011 +A1: 2014); RCM (AS/NZS CISPR 32: 2015); IC VoC (ICES-003: Issue 6, 2016); KC (KN 32: 2015, KN 35: 2015)
Safety	UL (UL 60950-1); CB (IEC 60950-1:2005 + Am 1:2009 + Am 2:2013, IEC 62368-1:2014); CE-LVD (EN 60950-1:2005 + Am 1:2009 + Am 2:2013, IEC 62368-1:2014); BIS (IS 13252(Part 1):2010+A1:2013+A2:2015); LOA (IEC/EN 60950-1)
Environment	CE-RoHS (2011/65/EU); WEEE (2012/19/EU); Reach (Regulation (EC) No 1907/2006)
Protection	Ingress protection: IP67 (IEC 60529-2013)

## ▪ Available Model

DS-2CD2347G2-LU (2.8 mm, 4 mm, 6 mm)

DS-2CD2347G2-L (2.8 mm, 4 mm, 6 mm)



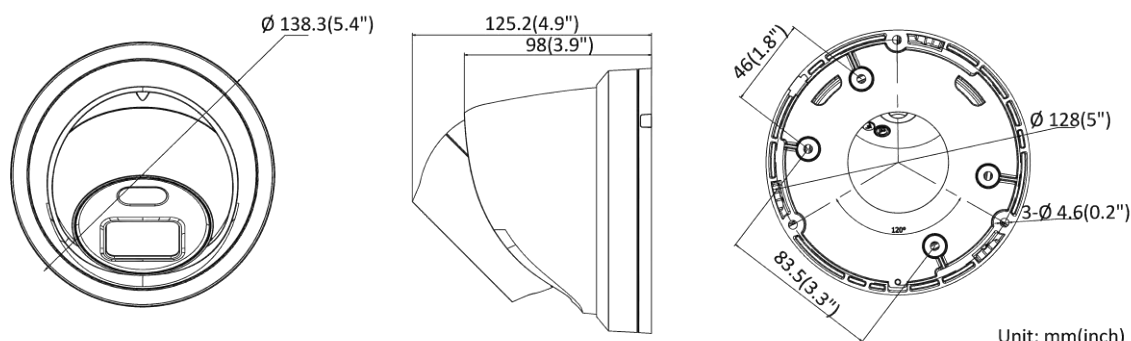



## ▪ Dimension



Unit: mm(inch)

▪ **Accessory**

▪ **Optional**

DS-1273ZJ-140B Wall Mount	DS-1271ZJ-140 Pendant Mount	DS-1273ZJ-140 Wall Mount	DS-1280ZJ-DM21 Junction Box	DS-1276ZJ-SUS Corner Mount
				
				
<p><b>DS-1275ZJ-SUS</b> <b>Vertical Pole Mount</b></p>				
				
				

Distributed by

**HIKVISION®****Headquarters**

No.555 Qianmo Road, Binjiang District,  
Hangzhou 310051, China  
T +86-571-8807-5998  
overseasbusiness@hikvision.com

**Hikvision USA**  
T +1-909-895-0400  
sales.usa@hikvision.com

**Hikvision Australia**  
T +61-2-8599-4233  
salesau@hikvision.com

**Hikvision India**  
T +91-22-28468900  
sales@pramahikvision.com

**Hikvision Canada**  
T +1-866-200-8690  
sales.canada@hikvision.com

**Hikvision Thailand**  
T +662-275-9949  
sales.thailand@hikvision.com

**Hikvision Europe**  
T +31-23-5542770  
sales.eu@hikvision.com

**Hikvision Italy**  
T +39-0438-6902  
info.it@hikvision.com

**Hikvision Brazil**  
T +55 11 3318-0050  
Latam.support@hikvision.com

**Hikvision Turkey**  
T +90 (216)521 7070- 7074  
sales.tr@hikvision.com

**Hikvision Malaysia**  
T +601-7652-2413  
sales.my@hikvision.com

**Hikvision UK & Ireland**  
T +01628-902140  
sales.uk@hikvision.com

**Hikvision South Africa**  
Tel: +27 (10) 0351172  
sale.africa@hikvision.com

**Hikvision France**  
T +33(0)1-85-330-450  
info.fr@hikvision.com

**Hikvision Kazakhstan**  
T +7-727-9730667  
nikia.panfilov@hikvision.ru

**Hikvision Vietnam**  
T +84-974270888  
sales.vt@hikvision.com

**Hikvision UAE**  
T +971-4-4432090  
salesme@hikvision.com

**Hikvision Singapore**  
T +65-6684-4718  
sg@hikvision.com

**Hikvision Spain**  
T +34-91-737-16-55  
info.es@hikvision.com

**Hikvision Tashkent**  
T +99-87-1238-9438  
uzb@hikvision.ru

**Hikvision Hong Kong**  
T +852-2151-1761  
info.hk@hikvision.com

**Hikvision Russia**  
T +7-495-669-67-99  
saleru@hikvision.com

**Hikvision Korea**  
T +82-(0)31-731-8817  
sales.korea@hikvision.com

**Hikvision Poland**  
T +48-22-460-01-50  
info.pl@hikvision.com

**Hikvision Indonesia**  
T +62-21-2933759  
Sales.Indonesia@hikvision.com

**Hikvision Colombia**  
sales.colombia@hikvision.com

## DS-7600NI-Q2/P SERIES NVR



### Features and Functions

#### HD Input

- H.265+/H.265/H.264/H.264+ video formats
- Connectable to the third-party network cameras
- Up to 16 IP cameras can be connected
- Recording at up to 8 MP resolution
- Supports live view, storage, and playback of the connected camera at up to 8 MP resolution

#### HD Output

- HDMI and VGA independent outputs
- HDMI Video output at up to 4K (3840 × 2160) resolution

#### HD Storage

- 2 SATA interfaces connectable for recording and backup
- H.265+ compression effectively reduces the storage space and costs by up to 75%

#### HD Transmission

- 1 self-adaptive 10/100/1000 Mbps network interface
- 8/16 independent PoE network interfaces are provided

#### Various Applications

- Centralized management of IP cameras, including configuration, information import/export, real-time information display, two-way audio, upgrade, etc.
- Connectable to smart IP cameras from Hikvision and the recording, playing back, and backing up of VCA alarms can be realized
- VCA detection alarm is supported
- Instant playback for assigned channel during multi-channel display mode
- Smart search for the selected area in the video; and smart playback to improve the playback efficiency
- Hik-Connect for easy network management





## Specifications

Model		DS-7608NI-Q2/8P	DS-7616NI-Q2/16P
Video/Audio input	IP video input	8-ch Up to 8 MP resolution	16-ch
	Two-way audio	1-ch, RCA (2.0 Vp-p, 1 k Ω)	
Network	Incoming bandwidth	80 Mbps	160 Mbps
	Outgoing bandwidth	80 Mbps	
Video/Audio output	Recording resolution	8 MP/6 MP/5 MP/4 MP/3 MP/1080p/UXGA /720p/VGA/4CIF/DCIF/2CIF/CIF/QCIF	
	HDMI output resolution	1-ch, 4K (3840 × 2160)/30Hz, 1920 × 1080p/60Hz, 1600 × 1200/60Hz, 1280 × 1024/60Hz, 1280 × 720/60Hz, 1024 × 768/60Hz	
	VGA output resolution	1-ch, 1920 × 1080p/60Hz, 1280 × 1024/60Hz, 1280 × 720/60Hz, 1024 × 768/60Hz	
	Audio output	1-ch, RCA (Linear, 1 KΩ)	
Decoding	Decoding format	H.265/H.265+/H.264/H.264+/MPEG4	
	Live view / Playback resolution	8 MP/6 MP/5 MP/4 MP/3 MP/1080p/UXGA /720p/VGA/4CIF/DCIF/2CIF/CIF/QCIF	
	Synchronous playback	8-ch	16-ch
	Capability	1-ch @ 8 MP / 4-ch @ 1080p	
Network management	Network protocols	TCP/IP, DHCP, Hik-Connect, DNS, DDNS, NTP, SADP, SMTP, NFS, iSCSI, UPnP™, HTTPS	
Hard disk	SATA	2 SATA interfaces	
	Capacity	Up to 6TB capacity for each disk	
External interface	Network interface	1, RJ-45 10/100/1000 Mbps self-adaptive Ethernet interface	
	USB interface	2 × USB 2.0	
POE Interface	Interface	8, RJ-45 10/100 Mbps self-adaptive Ethernet interface	16, RJ-45 10/100 Mbps self-adaptive Ethernet interface
	Power	≤ 80W	≤ 150W
	Standard	IEEE 802.3 af/at	
General	Power supply	100 to 240 VAC	
	Power	≤ 180W	≤ 280W
	Consumption (without hard disk)	≤ 15W	
	Working temperature	-10 to +55° C (+14 to +131° F)	
	Working humidity	10 to 90 %	
	Chassis	1U chassis	
	Dimensions (W × D × H)	385 × 315 × 52 mm (15.2"× 12.4" × 2.0")	
Weight(without hard disk)	≤ 3 kg (6.6 lb)		

## Physical Interfaces

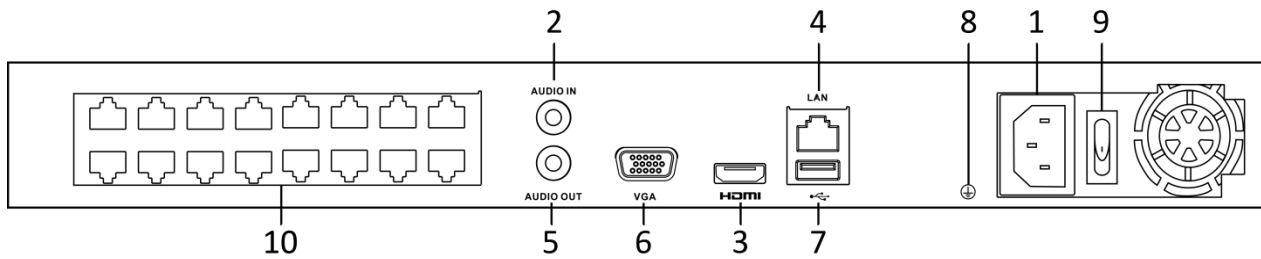

Index	Description	Index	Description
1	Power Supply	6	VGA Interface
2	Audio In	7	USB Interface
3	HDMI Interface	8	Ground
4	LAN Network Interface	9	Power Switch
5	Audio Out	10	Network Interfaces with PoE function (8 interfaces for DS-7608NI-Q2/8P and 16 interfaces for DS-7616NI-Q2/16P)

## Available Models

DS-7608NI-Q2/8P, DS-7616NI-Q2/16P

Distributed by



### Headquarters

No.555 Qianmo Road, Binjiang District,  
Hangzhou 310051, China  
T +86-571-8607-5998  
overseasbusiness@hikvision.com

**Hikvision USA**  
T +1-909-895-0400  
sales.usa@hikvision.com

**Hikvision Italy**  
T +39-0438-6902  
info.it@hikvision.com

**Hikvision Singapore**  
T +65-6884-4718  
sg@hikvision.com

**Hikvision Africa**  
T +27 (0) 0351172  
sale.africa@hikvision.com

**Hikvision Europe**  
T +31-23-55-42-770  
info.eu@hikvision.com

**Hikvision France**  
T +33(0)1-85-330-450  
info.fr@hikvision.com

**Hikvision Oceania**  
T +61-2-8599-4233  
salesau@hikvision.com

**Hikvision Hong Kong**  
T +852-2151-1761

**Hikvision Middle East**  
T +971-4-8816086  
salesme@hikvision.com

**Hikvision Spain**  
T +34-91-737-16-55  
info.es@hikvision.com

**Hikvision Canada**  
T +1-909-895-0400  
sales.usa@hikvision.com

**Hikvision Russia**  
T +7-495-668-67-99  
saleru@hikvision.com

**Hikvision Poland**  
T +48-22-480-01-50  
poland@hikvision.com

**Hikvision Korea**  
T +82-31-731-8841  
sales.korea@hikvision.com

**Hikvision India**  
T -91-22-28469900  
sales@pramahikvision.com

**Hikvision UK**  
T -01628-902140  
support.uk@hikvision.com

**Hikvision Brazil**  
T -55 11 3318-0050  
Latam.support@hikvision.com



# AME Straight Technologies sent you an estimate

We look forward to working with you.

Show full details 

## Surface Water Plant Camera Lowest Estimates

<b>Conduit</b> (\$15.00 ea.) × 22 <i>Conduit for gate camera.</i>	\$330.00
<b>4x4 Junction Boxes</b> (\$20.00 ea.) × 16 <i>Boxes will be used to mount the cameras to, and to weatherproof camera connections.</i>	\$320.00
<b>3/4 Lb</b> (\$10.00 ea.) × 2	\$20.00
<b>45° Sweep</b> (\$2.00 ea.) × 2	\$4.00
<b>90° Sweep</b> (\$2.00 ea.) × 4	\$8.00
<b>Couplings</b> (\$0.50 ea.) × 6	\$3.00
<b>Modular Ends</b> (\$2.00 ea.) × 32	\$64.00

<b>Cat 6</b>	<b>\$1,600.00</b>
(\$0.40/ft) × 4,000.00 <i>Wiring for all 16 cameras</i>	
<b>Maintenance/troubleshooting/repair</b>	<b>\$5,200.00</b>
(\$65.00 ea.) × 80 Maintenance/Troubleshooting/Repairs <i>It should take 2 technicians approximately 40 hours to install the camera systems at both buildings.</i>	
<b>Hotel</b>	<b>\$960.00</b>
(\$120.00 ea.) × 8 <i>Two rooms for 4 nights</i>	
<b>Camera System (Least Expensive Option)</b>	<b>\$1,900.00</b>
(\$950.00 ea.) × 2 <i>This includes a 2TB NVR that supports 8 cameras. And 8 4K dome cameras. Camera specs 125° viewing angle, 150' daytime viewing depth and 98' IR color night vision. Variable frame rate that maxes out at 8 mp@15fps. This is an IP (or wired) camera system.</i>	
<i>Camera locations. Main building</i>	
<i>1 gate</i>	
<i>2 service</i>	
<i>3</i>	
<i>4</i>	
<b>Subtotal</b>	<b>\$10,409.00</b>
<b>Total</b>	<b>\$10,409.00</b>

**AME Straight Technologies**

© 2023 Block, Inc.  
All rights reserved.

[Square Privacy Policy](#) | [Security](#)



**OKEECHOBEE UTILITY AUTHORITY**

AGENDA ITEM NO. 20

NOVEMBER 21, 2023

**CEMETERY ROAD WWTF ENTRANCE ROAD PAVING**

The Okeechobee Utility Authority requested quotes for milling and resurfacing the entrance road from Cemetery Road to the front of the office. Of the three contractors, one responded that he could not do the work (Sweat Trucking & Paving) with two others providing a quote.

Streamline Paving, Inc.	\$128,482.20
C.W. Roberts Contracting, Inc	\$202,580.97

The FY24 Budget allocated, \$106,500 for this work. OUA staff can make up the difference by use of a contingency line item as a option if the OUA Board approves this expenditure.

This work is in the budget and the road does need the work. It is the recommendation of staff to the OUA Board to consider approval of the proposal from Streamline Paving, Inc. for \$128,482,20.

# PROPOSAL

## Streamline Paving Inc.

4525 State Road 70 E

Okeechobee, FL 34972

(863) 634-0081

StreamlinePavingInc@hotmail.com

Date: 10/17/2023

Client Name:

Location:

Jamie Gamiotea

Okeechobee Waste Water Authority

OUA

We hereby submit specification and estimate to perform work at the above job site:

1. Mill & Stabilize Several Locations Along Main Road from Deterioration of the Road Number to Sweep & Clean All Asphalt Surfaces of the Main Road.
2. Mill Any Transitions needed from Buildings or Connecting Roads / Tack Coat Complete Asphalt Surface of Main Road / Install 1 1/4 Inches of SP 9.5 Asphalt Overlay & Compact
3. This Project will consist from Cemetery Road all the way into Front of Main Office Parking Area

Estimated Sq Ft 77,868 at \$1.65 = \$ 128,482.20

Any Other Asphalt Overlay needed Inside of Waste Water Management Area will be looked at and agreed upon another proposal given upon request

Make all checks payable to STREAMLINE PAVING INC..

There will be a 10% surcharge late fee per invoice after 30 days of the date on the invoice

---

Signature

---

Date

# QUOTE PROPOSAL



## C.W. ROBERTS CONTRACTING, INC

806 NW 9th Street

Okeechobee, Fl. 34972

Contact: Pete Ramsdell

Phone: 863.763.7373

Email: pramsdell@cwrcontracting.com

Quote To: Okeechobee Utility Authority  
 Attn: Mr. Jamie Gamioatea  
 Phone: 863.763.3322  
 Email: jgamioatea@ouaf1.com  
 100 SW 5th Avenue  
 Okeechobee, Florida 34974-4221  
 Fax: 863.467.5150

Job Name: OUA Entrance Rd. from Cemetary Rd.  
 Date of Plans: None Available  
 Revision Date: N/A  
 Quote Revision: N/A

ITEM	DESCRIPTION	QUANTITY	UNIT	UNITPRICE	AMOUNT
100	MOBILIZATION-SUPER VISION-MOT	1.00	LS	10,323.07	10,323.07
200	ASPHALT REMOVAL BLDG FRONT	210.00	SY	24.34	5,111.40
300	MILL EXISTING ASPHALT IN THE ROADWAY 1" MAXIMUM.	11,730.00	SY	2.00	23,460.00
400	INSTALL 1.5" SP-9.5 ASPHALT IN ROAD AND PARKING	12,170.00	SY	13.45	163,686.50
<b>GRAND TOTAL</b>					<b>\$202,580.97</b>

**NOTES:**

Bituminous Tack Coat is included in Asphalt prices.  
 Bond is not included. Add 1.5% if required.  
 Erosion Control is not included. Preparation of a SWPPP, and stormwater inspection, monitoring and reporting are not included.  
 Temporary striping and removal is not included.  
 Layout is not included.  
 QC is not included.  
 Grassing, Sod, Temp Grassing is not included.  
 Permit Fees, If required, is not included.  
 Drainage of pavement surface where the design slope is less than 2%, will not be guaranteed.  
 No removal, handling, treatment, disposal or replacement of unsuitable or hazardous material is included.  
 Pricing is based on 1 mobilization, add \$5,000 for each additional mobilization.  
 CWR will not be responsible for the protection or cleaning of any decorative brick pavers, curbing, bridge decks, driveways, etc. while performing our portion of the work.  
 Should the Owner or Contractor require a form other than CWR's Contract Agreement, CWR's full proposal must be incorporated into Owner's or Contractor's agreement and must be signed by an authorized representativ  
 Payment in full for all work performed hereunder during any month shall be made not later than the tenth day of the month next following.  
 This proposal expires thirty (30) days from the date hereof, but may be accepted at any later date at the sole option of CWR.  
 If the foregoing meets with your acceptance, kindly sign and return this proposal. Upon its' receipt it is understood and the foregoing will constitute the full and complete agreement between us.

AcceptedBy: \_\_\_\_\_  
 Name & Title

Daate: \_\_\_\_\_

# OKEECHOBEE UTILITY AUTHORITY

AGENDA ITEM NO. 21

NOVEMBER 21, 2023

## SWTP UPDATE

### Perimeter Fencing

Fencing (8' high with barbed wire on top) has been added to the eastern and western side lot lines and a SR78 section in front of the "Flores" property along with a short section fronting on SR78West. After installation of the 8' high fencing, one small section along SR78 needed to be replaced (existing fencing damaged) and the fencing along the north property line did not meet the 8' height requirement, so it needs to be replaced.

### Wireless Security Camera

Discussed under separate agenda item.

### Interior Tank Safety

Several issues were discussed concerning tank safety:

What if someone were to fall in or otherwise get in an open air tank:

- To get out: OUA installed several ladders



Backwash Tank



Waste Tank



- If they fell in a tank with liquid in it



Backwash Tank



Filter Bay

- Prior to walking out on the catwalk over the backwash tank



Life Jacket Notice



Life Jacket Location

Employees are to wear life jackets found in the cabinet

**Storm Damage**

The enclosure over the filters has been repaired



Storm Damage



Repaired

The cover over the ammonia tank has been repaired



- Work is continuing on the
  - perimeter fencing, electric opening gate and access at the surface water treatment plant
  - Wireless cameras
  - Log in employee SCADA access control
  - Ozone generator cooling
  - Protection around panels on top of Acti-Flo

# **OKEECHOBEE UTILITY AUTHORITY**

AGENDA ITEM NO. 22

NOVEMBER 21, 2023

## **SAFETY COMMITTEE MEETING**

The OUA Board asked that the Safety Committee to review & discuss as to what could the PGIT reimbursement be used for. The OUA Board took no action on the agenda item which directed the reimbursement be given to staff in the form of a gift card as recognition of their diligence in making the OUA a safe work place. The OUA Board is interested in other possible uses.

At the October 25<sup>th</sup> meeting, the safety committee chairperson raised this subject and during the discussion, committee members offered up the following ideas:

- Look into driver safety training coursework, videos, etc.;
- A BBQ Safety Team meeting;
- A Self-defense/Gun Safety/Active Shooter class at the Sheriff's Gun Range;  
(could be done in conjunction with the BBQ Safety meeting)
- Gift Cards (good idea for each employee)

The gift card idea was discussed to only issue the cards to those employees that did not have safety infractions during the preceding year.

As a side note, PGIT will be conducting a safety inspection at all OUA facilities on November 30<sup>th</sup>. PGIT will also be bringing information on other available training opportunities either through in-person or virtual on-line.

Several committee members volunteered to look/search for other possible safety classes or training.

**OKEECHOBEE UTILITY AUTHORITY**

AGENDA ITEM NO. 23

NOVEMBER 21, 2023

**PUBLIC COMMENTS**

**OKEECHOBEE UTILITY AUTHORITY**

AGENDA ITEM NO. 24

NOVEMBER 21, 2023

**ITEMS FROM THE ATTORNEY**

# OKEECHOBEE UTILITY AUTHORITY

AGENDA ITEM NO. 25

NOVEMBER 21, 2023

## ITEMS FROM THE EXECUTIVE DIRECTOR

### Southwest Wastewater Service Area

- Project 1
  - Master Pump Station (MPS)      **Completed**
  - Master Force Main (MFM)      **Completed**
  - Force Main SE2 Interconnect  
    Anticipated bid advertisement Spring 2024
- Project 2 Collection System  
    Notice to Proceed issued on March 29, 2023  
    Substantial:    March 29, 2025 (731 calendar days from NTP)  
    Final:            May 12, 2025 (775 calendar days from NTP)  
    Construction underway
- Project 3 Okee-Tantie  
    Anticipated advertisement Spring 2024

### Pine Ridge Park Utility Improvements

- Notice to Proceed issued June 21, 2022
- Substantial Completion February 16, 2024 (425 calendar days from NTP + 181 days per Change Orders)
- Final Completion March 18, 2024 (455 calendar days from issuance NTP + 181 days per Change Orders)
  - Work has begun making water connections
  - Works continues on the vacuum station

### SW 5<sup>th</sup> Ave Wastewater System Improvements

- Initial engineering work underway

### US441SE Water Main Extension

- Under design

### Treasure Island Septic to Sewer Project

- Engineering design report due this month
- Initial force main layout due this month

### SR 78W Water Main Improvements Project

- Engineering RFP under consideration today
- Discussions with FDOT ongoing

### Septic to Sewer Connections

- Engineering RFP out for advertisement  
    First area to be considered for connections: Taylor Creek Isles

**OKEECHOBEE UTILITY AUTHORITY**

AGENDA ITEM NO. 26

\NOVEMBER 21, 2023

**ITEMS FROM THE BOARD**

- OUA Staff Holiday Party – December 7, 2023 at 12:00PM – Maintenance Barn