

Technical Drawings

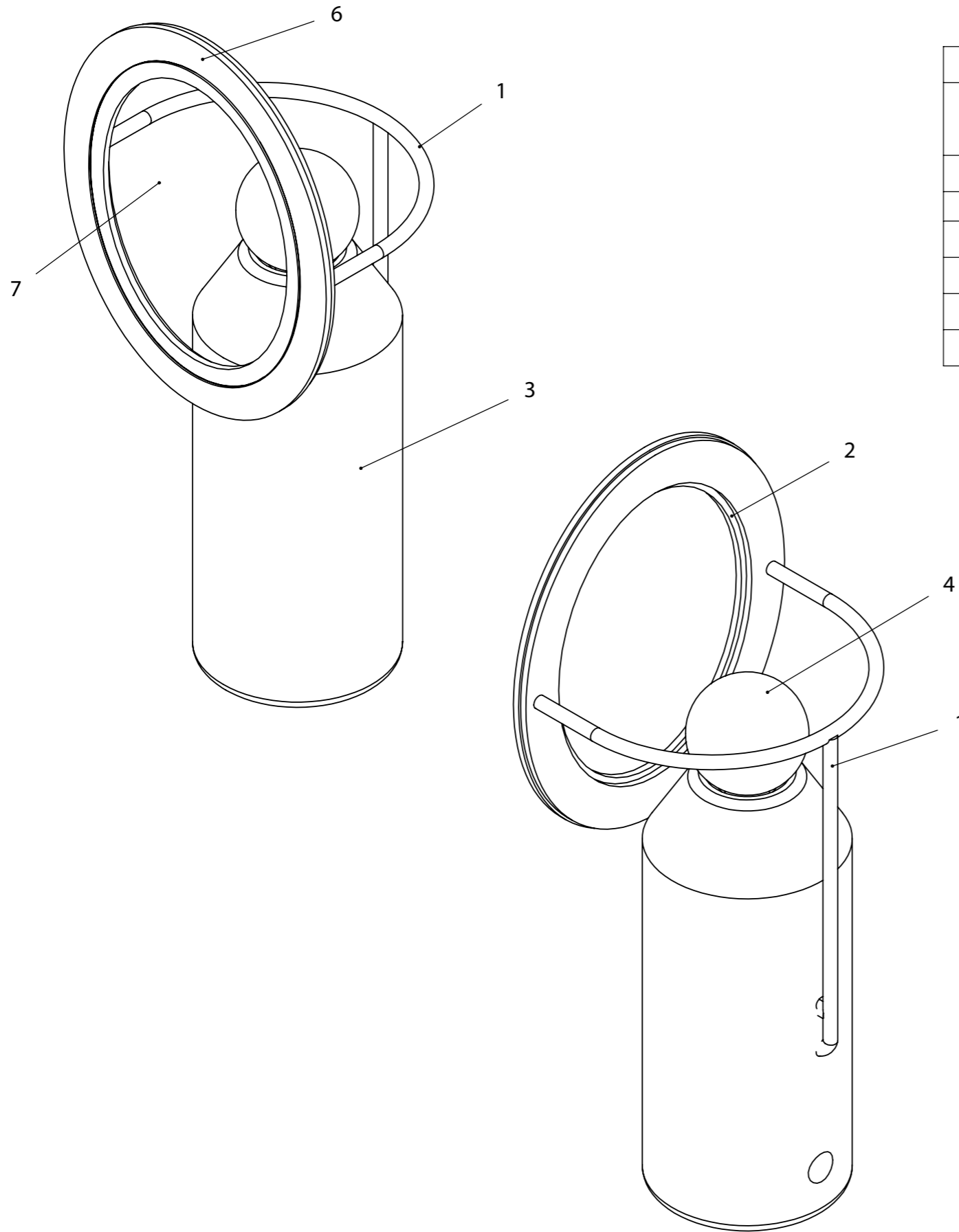

ITEM NO.	PART NUMBER	DESCRIPTION	QTY.
1	BACK FRAME AND ROD	BRASS	1
2	MIDDLE FRAME	BRASS	1
3	BASE	ASH	1
4	BULB	TALA SPHERE I BULB	1
5	BULB HOLDER	BOUGHT IN - CERAMIC	1
6	FRONT FRAME	BRASS	1
7	FABRIC	LINEN	1

Bill of Materials

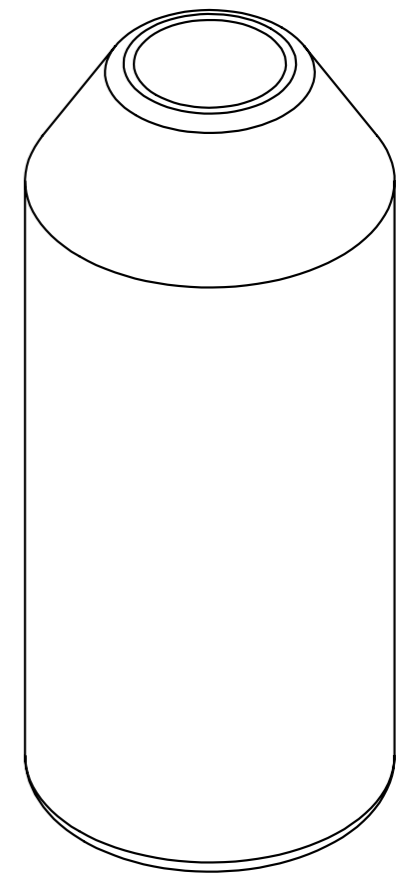
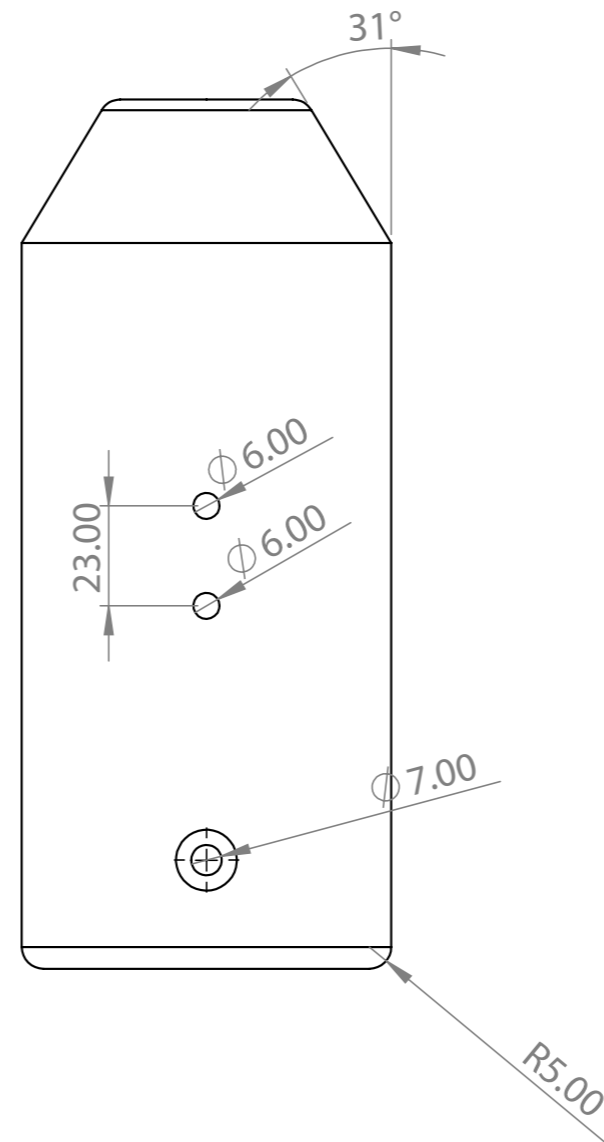
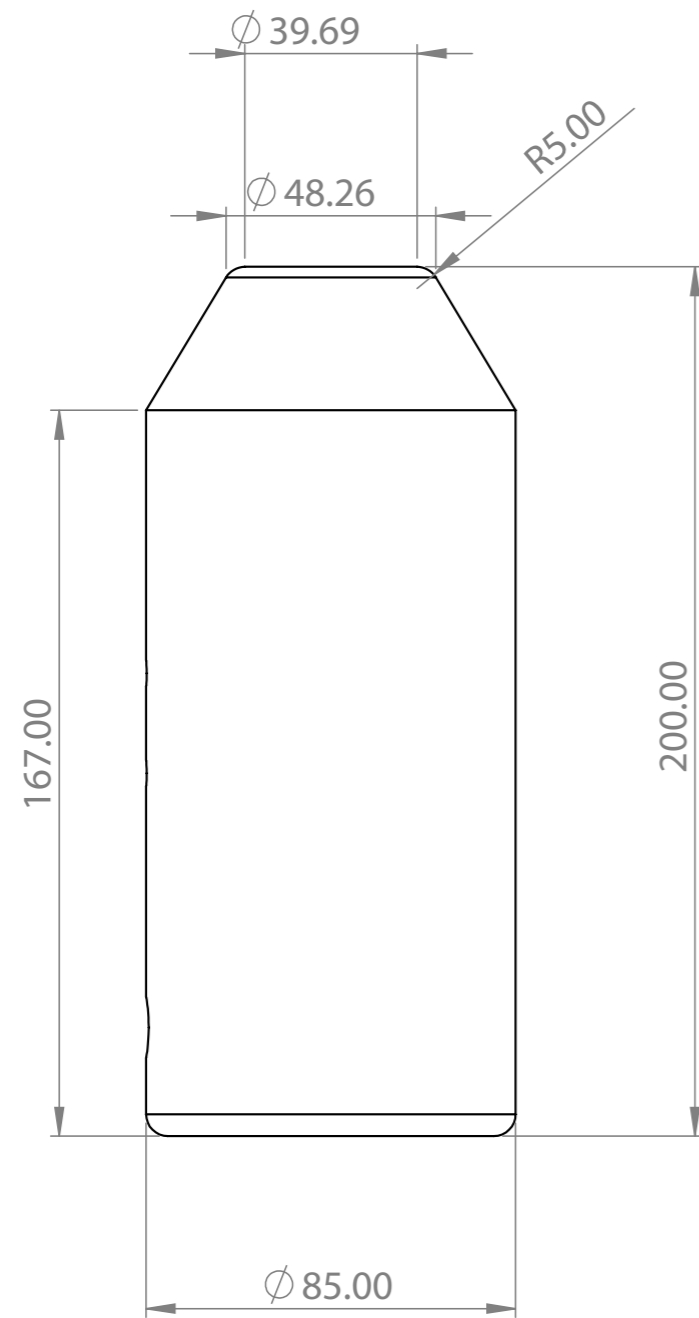

Ash Base

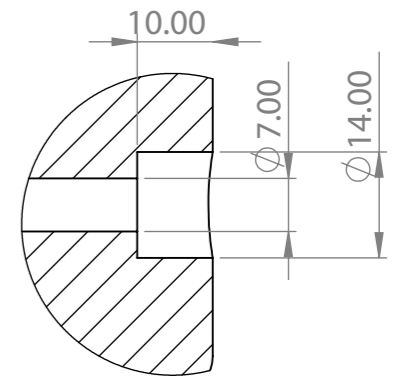
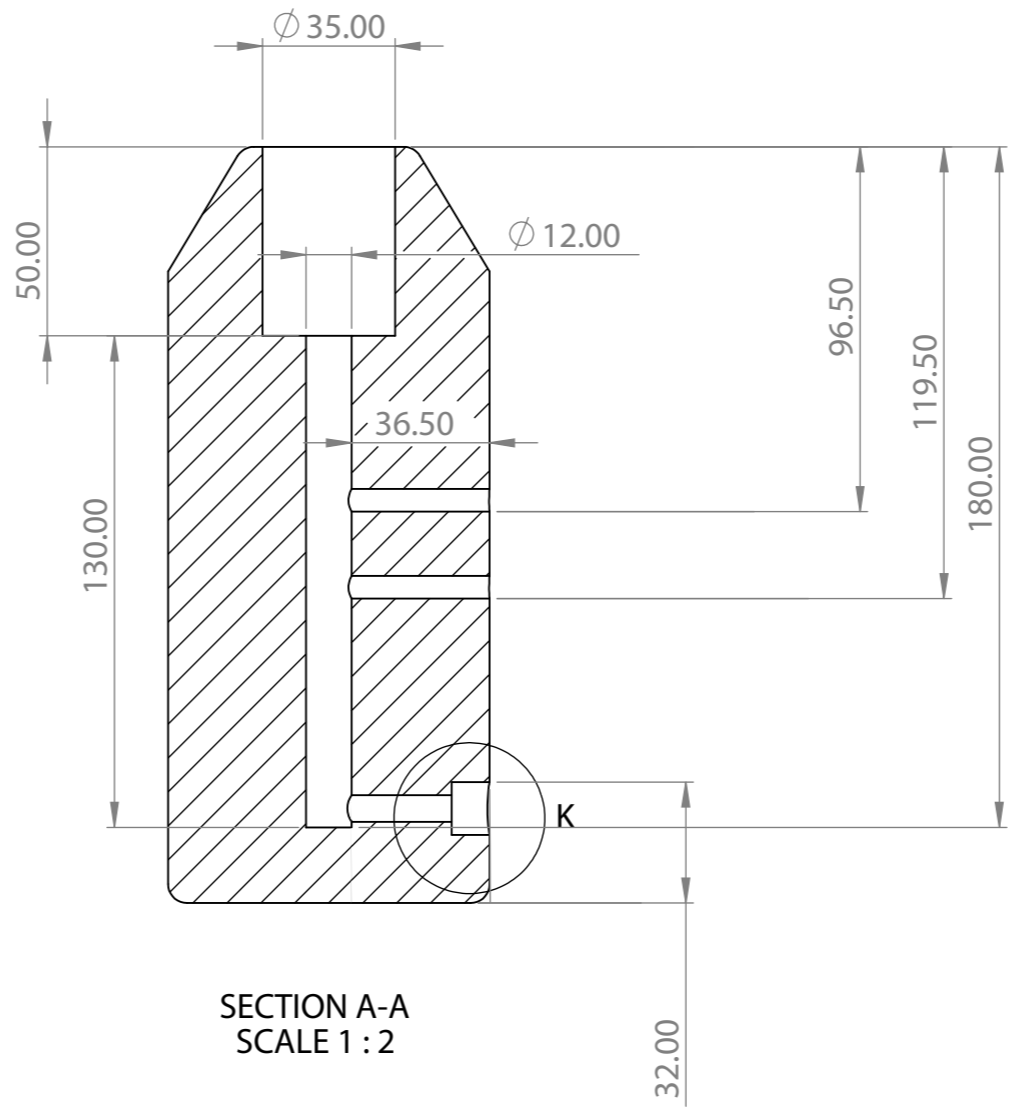
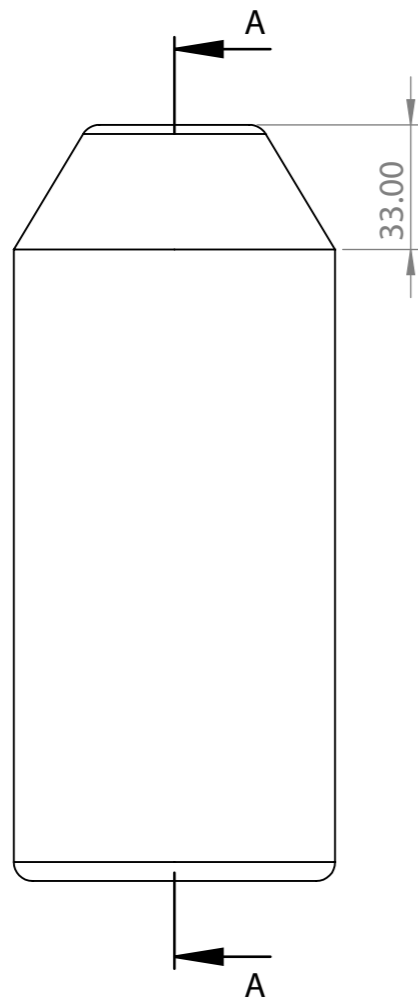

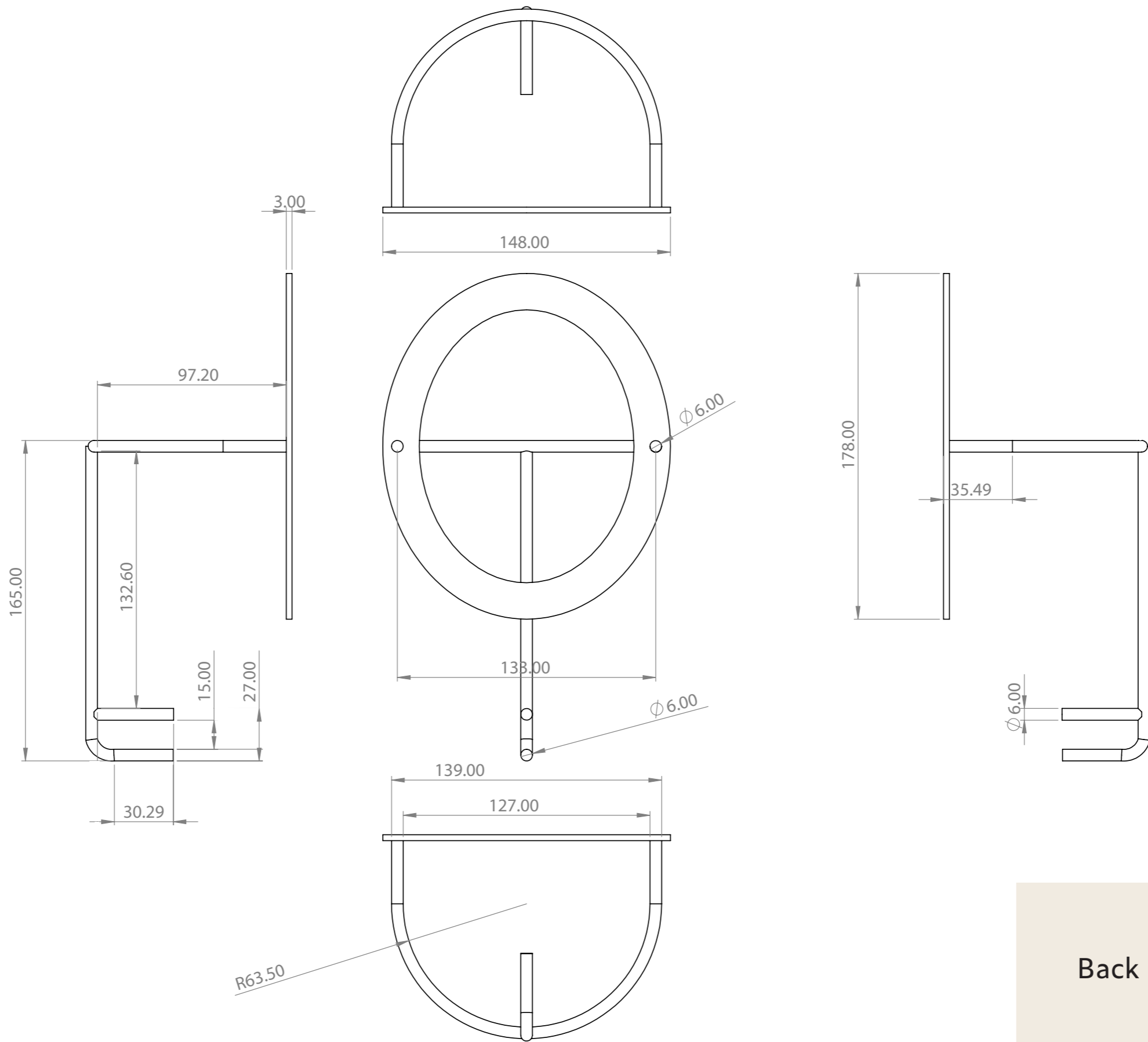

Back Brass Frame and Brass Rods

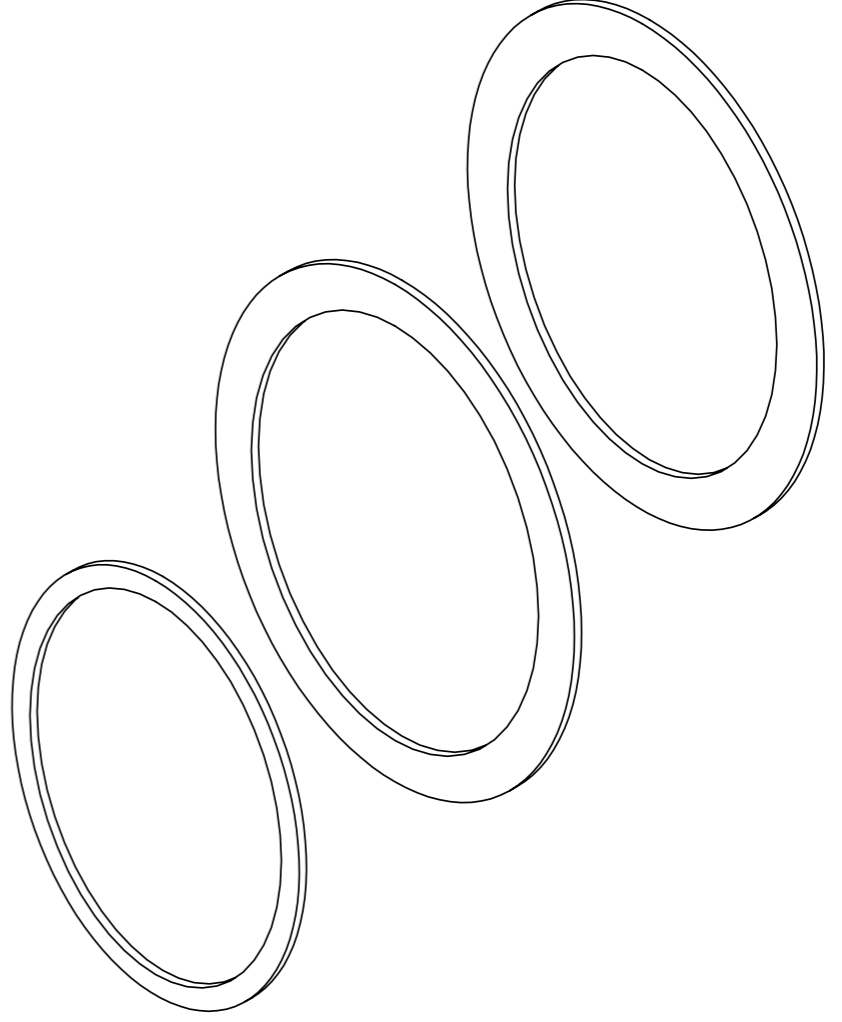
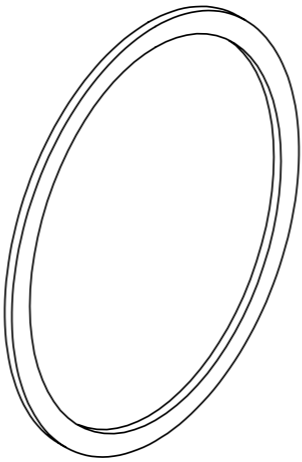
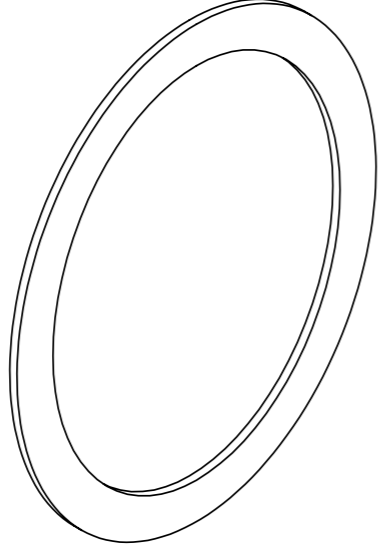
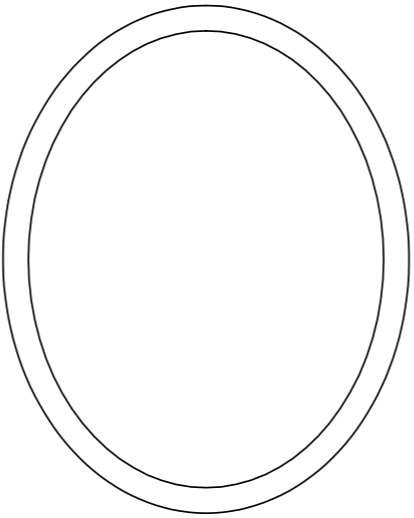
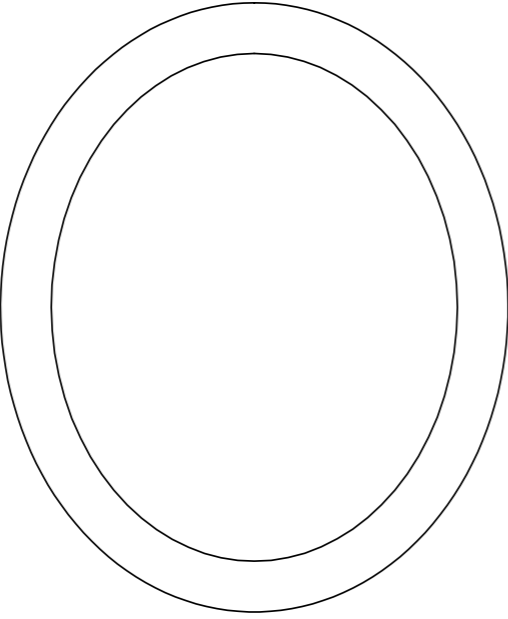
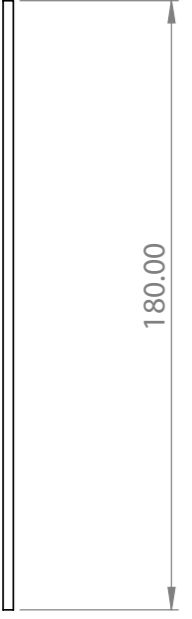
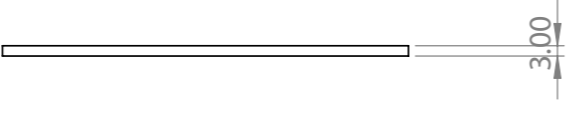
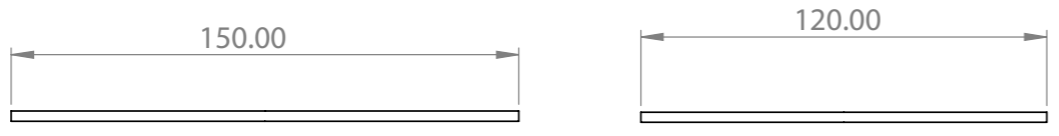

Front and Middle Brass
Frames