

RUNXIN MULTI-PORT CONTROL VALVES



SPECIAL EDITION FOR
REDAWATERGROUP



WWW.REDAWATERGROUP.COM



RUNXIN MULTIPORT CONTROL VALVES

Simple installation with less leak points

Integrate multiple valves into one valve, which make the connection easier and more efficient and significantly reduce leak risk .

Easy Maintenance

Fewer connections make maintenance easy and fast. Just replace the worn accessory of Runxin control valves, which can save more costs and increase efficiency.

Automatic Operation

Just set the process in advance, it can achieve automatic operation.

VS

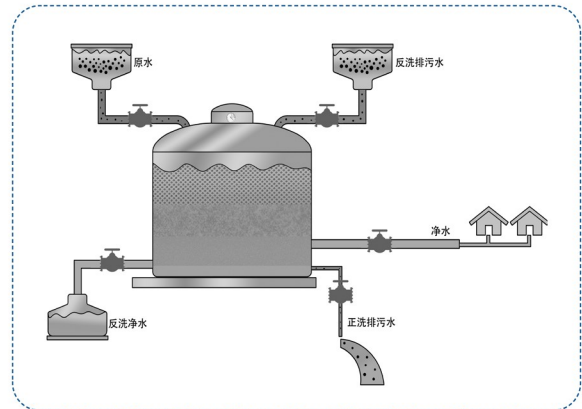

TRADITIONAL PIPELINE SYSTEM

Complex connections and many leak points

5,7,11 and more valves pipe connections in filtering, softening and ion exchange systems cause hard installation many potential leak points.

Hard Maintenance

Multiple connections make the leak risk increase. Besides, the repair and maintenance will spend too many labor and downtime time costs.

All-Manual Operation

Manually operate many valves open and close will spend long time and easy to have internal water mixing.



Structure – Features

A

Hermetic Head Faces Construction

Because of good corrosion resistance, Runxin control valve has a very good application in Anion/Cation ion-exchange system.

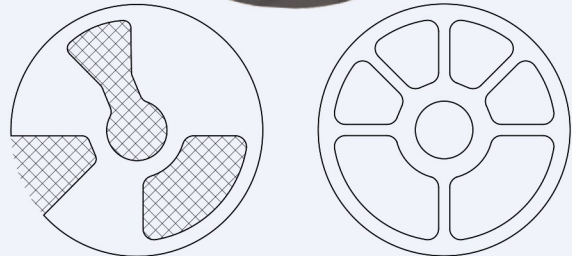

Ceramic Moving Disk

- i. Ceramic Disk is sintered at 1680 °C.
- ii. Content : $\text{Al}_2\text{O}_3 \geq 95\%$
- iii. $\text{HRA} \geq 85^\circ$, Flatness ≤ 0.0003 mm, Parallelism ≤ 0.015 mm
- iv. Acid and alkaline resistance: Ceramic has excellent stability against Inorganic acid and alkaline at normal temperature.

High Strength Synthetic Fixed Disk

- i. High Strength Synthetic material ensure the fixed disk resisting corrosion from many kinds acids and strong alkalines except hot concentrated Nitric acid.
- ii. The fixed disk is grinded to have same flatness as the ceramic moving disk to keep good and reliable sealing.
- iii. Hermetic head faces construction has better ability to prevent damage from foreign substance in the water.

Partly Balance Construction

For each softener valve, it adopts partly balance construction to prevent big torque as water pressure increasing.

B

Operate with Pressure

Runxin valve uses two high-flatness sealing disks closely located respectively. When switch the working positions, it could operate with pressure.

While some other valves which uses soft sealing element like rubber parts, it can't operate with pressure. It needs to shut off the inlet valve before switching.

G

No Hard Water Bypass Option

No Hard Water Bypass (NHWP) means the valve can internally prevent raw water from getting into service lines during regeneration.

All Runxin valves can shut off the passage to outlet during regeneration except Model: F79B, F82B, F92B.

D

Varieties of Specifications injector

The ratio of injector draw to total flow rate is around 25% to 35%. Each tank has a specific injector matched.

Working Principle

Using hermetic head faces theory, Runxin valve is designed to integrate multi-ports round closely to one valve body. When the rotor rotates, some ports will be shut off and meanwhile some other ports will be open, and thus the water will flow in and out this valve.

Construction

Runxin valve uses high-flatness moving disk and fixed disk to work as a valve. Fixed disk is fixed and moving disk is driven by handle or motor to rotate closely over fixed disk. There are several blind via and through-holes on fixed disk and moving disk, when moving disk stays on different positions of fixed disk, and then different flow passages will be formed:

For softener valves

These positions are Service, Backwash, Brine & Slow Rinse, Brine Refill and Fast Rinse.

For Filter valve

It has 3 positions: Service, Backwash and Fast Rinse.

Here, we take the **F63** as example:

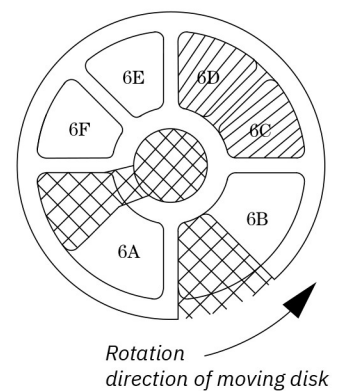
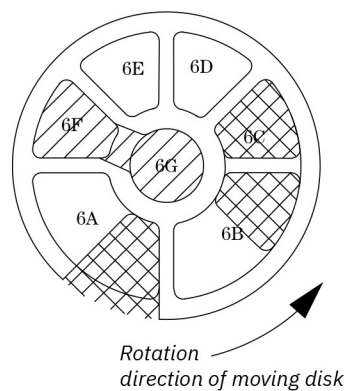
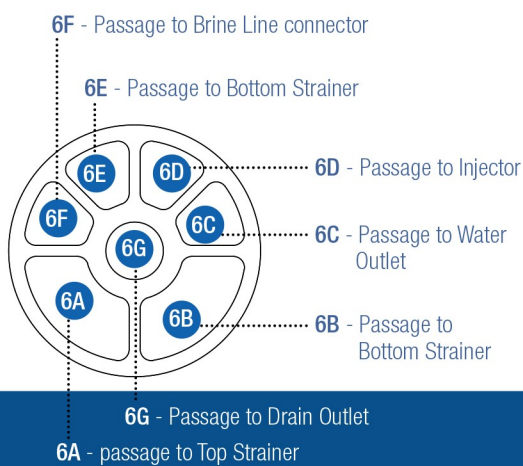
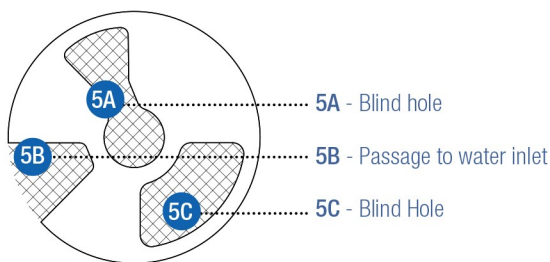

Service Position



Backwash Position

Controller



The controller gets signal from Timer, Meter or Water Quality Detecting Instrument, and then will initiate the motor to drive the actuator to rotate the moving disk, and when the moving disk rotates to the correct position, another signal will be sent to the controller through the locating device, and the controller will stop the moving disk until it finishes this step; When next new signal is received by the controller, the controller will drive the moving disk to rotate to a new position and so on until all steps are finished and cycled.

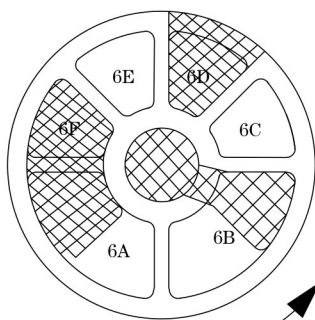
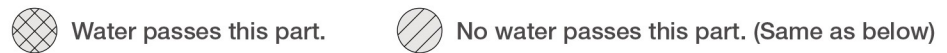

Rotation
direction of moving disk

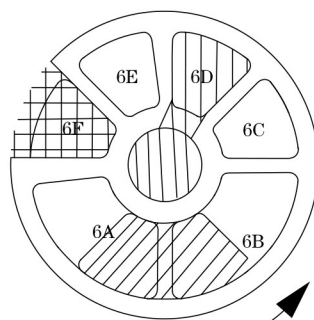

Rotation
direction of moving disk

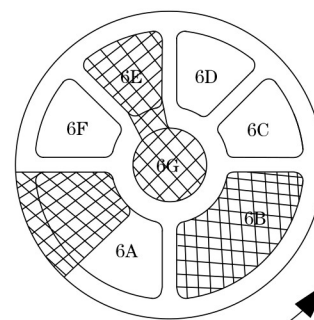

Rotation
direction of moving disk



Brine&Slow Rinse Position



Brine Refill Position



Fast Rinse Position

Applications & Industry

Runxin control valves (filter valves and softening valves) are core component during filtering and softening system. They are widely used in various fields to guarantee efficient and easier water treatment.

Filtering & Softening



Industrial Fields

Water filtering and softening for boiler, heat exchange equipment, cooling system and RO system.



Agriculture

Water filtering and softening for crops and flowers irrigation, livestock drinking, vegetables and fruits washing.



Residential

Water filtering and softening for drinking, bathing, cooking, as well as for electric boilers, water heaters, underfloor heating and other installations.



Commercial

Pre-filtering and softening of RO system for drinking and domestic use. It can be used for swimming pool filtering.





Process Water Treatment



Desalination (Pure and Ultra Pure Water)

Power station boiler make-up water, laboratory, electroplating plant, integrated circuit manufacturing, pharmaceutical preparations, biochemistry, drinking water, cosmetics and other fields.

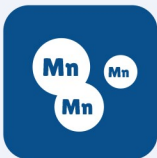

Iron and manganese removal filtration

Remove extra iron and manganese content in underground water for domestic and industrial production use.



Deaeration

Deaeration for boiler water to prevent piping, water tank, and other metal components from oxygen corrosion.



Defluoridation

Remove excess fluorine in underground water to protect people from fluorosis.



Runxin Code System



Examples

For 53610 control valve

5 means filter valve, **3** means LED display automatic control, **6** means meter type, **10** means water treatment capacity is 10 m³/h

That is,

53610 means meter type automatic filter valve with water treatment capacity of 10 m³/h.

Special Application Control Valves

For code beginning with 1 are control valves for special applications, and for code beginning with 4 are spare parts. The meaning of the first two digits refers to the following chart.

For code beginning with 1

Code	➤	11	13	15	17	18
Special Applications	➤	Control valve for fluoride removal	Control valve for deaerator	Control valve for mixed bed system	Single valve with double tanks	Single valve with triple tanks

Control Valve Spare Parts

Code	➤	41	42	43	44	45	46	47	48
Special Applications	➤	Bypass Valve	Tee Valve	Brine Valve	Online Monitoring Device	Disk Filter	Controller	Disinfection Device	Salt Shortage Alarm Device

For 17610 control valve

17 means single valve with double tanks, **6** means meter type automatic softener valve,

10 means water treatment capacity is 10 m³/h,

That is,

17610 means single valve with double tanks, meter type automatic softener valve with water treatment capacity of 10 m³/h.

Manual Filter Control Valves

Structure & Performance Features

- Hermetic head faces structure.
- No hard water bypass and can operate with pressure.
- Manual regeneration. Handle could be rotated and assembled within 180°.

Applications

- Household Filter System (**F56A/F56E/F56F**).
- Activated carbon filter or sand filter system for RO pretreatment system.
- Swimming Pool Filter System (**N56D/F77BS**).
- **N56D/F77BS** can be used for Iron/Manganese Removal system if side mount adapter is installed upside down.



Popular Models



Model	51102 (F56E1) 51202 (F56E2)	51202C (F56EC)	51104 (F56A1) 51204 (F56A2)
Water Capacity	2 m ³ /h	2 m ³ /h	4 m ³ /h
Handle Material	Metal (E1) / Plastic (E2)	Plastic handwheel	Metal (A1) / Plastic (A2)
Mount Type	Top Mount	Top Mount, Side Control	Top Mount
Inlet/Outlet	1/2"F (-1) or 3/4"F (-2)	1/2"F (-1) or 3/4"F (-2)	1"F
Drain	1/2"F (-1) or 3/4"F (-2)	1/2"F (-1) or 3/4"F (-2)	1"F
Base	2.5"-8NPSM	2.5"-8NPSM	2.5"-8NPSM
Riser Pipe	1.05" OD	1.05" OD	1.05" OD
Available Tank Size	6"-10"	6"-10"	6"-12"
Working Pressure	0.15-0.6 MPa	0.15-0.6 MPa	0.15-0.6 MPa
Water Temperature	5-50 °C	5-50 °C	5-50 °C
Turbidity	< 20 FTU	< 20 FTU	< 20 FTU
Media	Sand / Activated Carbon	Sand / Activated Carbon	Sand / Activated Carbon



Model	51204C (F56AC)	51204K (F56K)	51106 (F56F1) 51206 (F56F2)
Water Capacity	4 m³/h	4 m³/h	6 m³/h
Handle Material	Plastic handwheel	Plastic	Metal (F1) / Plastic (F2)
Mount Type	Top Mount, Side control	Top Mount	Top Mount
Inlet/Outlet	1"F	1"F	1"F Right in & Left Out
Drain	1"F	1"F	1"F
Base	2.5"-8NPSM	2.5"-8NPSM	2.5"-8NPSM
Riser Pipe	1.05" OD	1.05" OD	1"D-GB
Available Tank Size	6"-12"	6"-12"	6"-14"
Working Pressure	0.15-0.6 MPa	0.15-0.6 MPa	0.15-0.6 MPa
Water Temperature	5-50 °C	5-50 °C	5-50 °C
Turbidity	< 20 FTU	< 20 FTU	< 20 FTU
Media	Sand / Activated Carbon	Sand / Activated Carbon	Sand / Activated Carbon



Model	51208 (F56L)	51110 (N56D1) 51210 (N56D2)	51215 (F77BS)	51240B (F112BS)
Water Capacity	8 m³/h	10 m³/h	15 m³/h	40 m³/h
Handle Material	Plastic handwheel	Metal (D1) / Plastic (D2)	Plastic Handwheel	Plastic handwheel
Mount Type	Top Mount	Top/Side Mount	Top/Side Mount	Side Mount
Inlet/Outlet	1.5"M	2"F	2"M	DN65
Drain	1.5"M	2"F	2"M	DN65
Base	4"-8UN	4"-8UN	4"-8UN	-
Riser Pipe	1.25"D-GB / 1.66" OD	1.5"D-GB / 1.9" OD	1.5"D-GB / 1.9" OD	Side Mount, Top and bottom DN80
Available Tank Size	10" - 24"	10" - 24"	30" - 36"	36" - 48"
Working Pressure	0.15-0.6 MPa	0.15-0.6 MPa	0.2-0.6 MPa	0.2-0.6 MPa
Water Temperature	5-50 °C	5-50 °C	5-50 °C	5-50 °C
Turbidity	< 20 FTU	< 20 FTU	< 20 FTU	< 20 FTU
Media	Sand / Activated Carbon	Sand / Activated Carbon	Sand / Activated Carbon	Sand / Activated Carbon

Automatic Filter Control Valves

Structure & Performance Features

- LED display, indication of long time power off and data saved after power off (Saved for three days).
- No hard water bypass in rising cycle.
- With signal output connector and two modes (b-01 or b-02) are optional.
- Can set rinsing frequency F-00, realizing one time service and several times of backwash and fast rinse.
- With remote control connector to receive passive signals.
- With interlock connector to realize service simultaneously and rinse one by one.
- Start rising by days or hours.
- **N77, F95** and **F111** have two valve cores, one is for controlling inlet water, the other is for outlet water.
- Time clock type or meter type is optional.
- **N77/F95 with RS-485** port are optional.

Applications

- Residential Filter System (**F71/F67**).
- Activated carbon filter or sand filter system for RO pretreatment system.



Popular Models



Model	53502 (F71 B1) 53602 (F71 B3)	53502B (F71 G1)	56603 (F67M)
Water Capacity	2 m ³ /h	2 m ³ /h	3 m ³ /h
Running Model	Time Clock (B1) / Meter (B3)	Time Clock	Meter
Mount Type	Top Mount	Top Mount	Top Mount
Inlet/Outlet	3/4"M	3/4"M	3/4"M
Drain	3/4"M	3/4"M	3/4"M
Base	2.5"-8NPSM	2.5"-8NPSM	2.5"-8NPSM
Riser Pipe	1.05" OD	1.05" OD	1.05" OD
Available Tank Size	6"-10"	6"-10"	6"-10"
Working Pressure	0.15-0.6 MPa	0.15-0.6 MPa	0.15-0.6 MPa
Water Temperature	5-50 °C	5-50 °C	5-50 °C
Turbidity	< 20 FTU	< 20 FTU	< 20 FTU
Media	Sand / Activated Carbon	Sand / Activated Carbon	Sand / Activated Carbon
Input Charge	AC 100V - 240V / 50-60 Hz	AC 100V - 240V / 50-60 Hz	AC 100V - 240V / 50-60 Hz
Transformer Output	DC 12V/1.5A	DC 12V/1.5A	DC 12V/1.5A



Model	53504 (F67C1) 53604 (F67C3)	53504S (F67B1) 53604S (F67B3)	53504B (F67G1)	53504C (F67H1)
Water Capacity	4 m³/h	4 m³/h	4 m³/h	4 m³/h
Running Model	Time Clock (C1) / Meter (C3)	Time Clock (B1) / Meter (B3)	Time Clock	Time Clock
Mount Type	Top Mount	Top Mount	Top Mount	Top Mount
Inlet/Outlet	1"F	1"F	1"F	1"F
Drain	1"F	1"F	1"F	1"F
Base	2.5"-8NPSM	2.5"-8NPSM	2.5"-8NPSM	2.5"-8NPSM
Riser Pipe	1.05" OD	1.05" OD	1.05" OD	1.05" OD
Available Tank Size	6"-14"	6"-14"	6"-14"	6"-14"
Working Pressure	0.15-0.6 MPa	0.15-0.6 MPa	0.15-0.6 MPa	0.15-0.6 MPa
Water Temperature	5-50 °C	5-50 °C	5-50 °C	5-50 °C
Turbidity	< 20 FTU	< 20 FTU	< 20 FTU	< 20 FTU
Media	Sand / Activated Carbon	Sand / Activated Carbon	Sand / Activated Carbon	Sand / Activated Carbon
Input Charge	AC 100V - 240V / 50-60 Hz	AC 100V - 240V / 50-60 Hz	AC 100V - 240V / 50-60 Hz	AC 100V - 240V / 50-60 Hz
Transformer Output	DC 12V/1.5A	DC 12V/1.5A	DC 12V/1.5A	DC 12V/1.5A



Model	52504E (F67K)	53506S (F67B1-A) 53606S (F67B3-A)	53508 (F134A1) 53608 (F134A3)	53510 (N75A1) 53610 (N75A3)
Water Capacity	4 m³/h	4 m³/h	8 m³/h	10 m³/h
Running Model	Time Clock	Time Clock (B1) / Meter (B3)	Time Clock (A1) / Meter (A3)	Time Clock (A1) / Meter (A3)
Mount Type	Top Mount	Top Mount	Top Mount	Top Mount
Inlet/Outlet	1"M	1"F	1.5"M	2"M
Drain	1/2"M	1"F	1.5"M	2"M
Base	2.5"-8NPSM	2.5"-8NPSM	4"-8UN	4"-8UN
Riser Pipe	1.05" OD	1"D-GB	1.25"D-GB or 1.66" OD	1.5"D-GB or 1.9" OD
Available Tank Size	6"-14"	6"-14"	16"-18"	16"-21"
Working Pressure	0.15-0.6 MPa	0.15-0.6 MPa	0.2-0.6 MPa	0.15-0.6 MPa
Water Temperature	5-50 °C	5-50 °C	5-50 °C	5-50 °C
Turbidity	< 20 FTU	< 20 FTU	< 20 FTU	< 20 FTU
Media	Sand / Activated Carbon	Sand / Activated Carbon	Sand / Activated Carbon	Sand / Activated Carbon
Input Charge	AC 100V - 240V / 50-60 Hz	AC 100V - 240V / 50-60 Hz	AC 100V - 240V / 50-60 Hz	AC 100V - 240V / 50-60 Hz
Transformer Output	DC 12V/1.5A	DC 12V/1.5A	DC 24V/1.5A	DC 24V/1.5A



Model	53510B (N75B1) 53610B (N75B3)	53515 (F99B1) 53615 (F99B3)	53518 (N77B1)
Water Capacity	10 m³/h	15 m³/h	18 m³/h
Running Model	Time Clock (B1) / Meter (B3)	Time Clock (B1) / Meter (B3)	Time Clock
Mount Type	Top/Side Mount	Top/Side Mount	Top/Side Mount
Inlet/Outlet	2"M	2"M	2"M
Drain	2"M	2"M	2"M
Base	4"-8UN	4"-8UN	4"-8UN
Riser Pipe	1.5"D-GB or 1.9" OD	1.5"D-GB or 1.9" OD	1.5"D-GB or 1.9" OD
Available Tank Size	6"-21"	20"-30"	30"-36"
Working Pressure	0.15-0.6 MPa	0.2-0.6 MPa	0.2-0.6 MPa
Water Temperature	5-50 °C	5-50 °C	5-50 °C
Turbidity	< 20 FTU	< 20 FTU	< 20 FTU
Media	Sand / Activated Carbon	Sand / Activated Carbon	Sand / Activated Carbon
Input Charge	AC 100V - 240V / 50-60 Hz	AC 100V - 240V / 50-60 Hz	AC 100V - 240V / 50-60 Hz
Transformer Output	DC 24V/1.5A	DC 24V/1.5A	DC 24V/1.5A



Model	53520 (F95B1) 53620 (F95B3)	53520T (F111B1) 53620T (F111B3)	53540B (F112B1) 53640B (F112B3)	53550 (F96B1) 53650 (F96B3)
Water Capacity	21.6 m³/h	20 m³/h	40 m³/h	50 m³/h
Running Model	Time Clock (B1) / Meter (B3)	Time Clock (B1) / Meter (B3)	Time Clock (B1) / Meter (B3)	Time Clock (B1) / Meter (B3)
Mount Type	Side Mount	Top Mount	Side Mount	Side Mount
Inlet/Outlet	2"M	2"M	DN65	DN80
Drain	2"M	2"M	DN65	DN80
Base	-	4"-8UN	-	-
Riser Pipe	Side mount top and bottom distributor 2"M	2"D-GB	Side mount, top and bottom distributor DN80	Side mount, top and bottom distributor DN100
Available Tank Size	30"-36"	30"-36"	36"-48"	36"-48"
Working Pressure	0.2-0.6 MPa	0.2-0.6 MPa	0.2-0.6 MPa	0.2-0.6 MPa
Water Temperature	5-50 °C	5-50 °C	5-50 °C	5-50 °C
Turbidity	< 20 FTU	< 20 FTU	< 20 FTU	< 20 FTU
Media	Sand / Activated Carbon	Sand / Activated Carbon	Sand / Activated Carbon	Sand / Activated Carbon
Input Charge	AC 100V - 240V / 50-60 Hz	AC 100V - 240V / 50-60 Hz	AC 100V - 240V / 50-60 Hz	AC 100V - 240V / 50-60 Hz
Transformer Output	DC 24V/1.5A	DC 24V/1.5A	DC 24V/4.0A	DC 24V/4.0A

Manual Softening Control Valves

Structure & Performance Features

- Hermetic head faces structure.
- No hard water bypass and can operate with pressure.
- Start regeneration by manual, and handle can be rotated 360° cycle.
- F64BC, F64AC could be side-operated.

Applications

- Residential Softener System(**F64A/F64AC/F64B/F64BC**).
- Softener system for RO.
- Boiler softener system; ion exchange units.



Popular Models



Model	61202 (F64B)	61202C (F64BC)
Water Capacity	2 m ³ /h	2 m ³ /h
Regeneration Type	Downflow	Downflow
Handle material	Plastic handwheel	Plastic handwheel
Mount Type	Top Mount	Top Mount
Inlet/Outlet	3/4"F	3/4"F
Drain	1/2"M	1/2"M
Brine Tank Connector	3/8"M	3/8"M
Base	2.5"-8NPSM	2.5"-8NPSM
Riser Pipe	1.05" OD	1.05" OD
Available Tank Size	6"-10"	6"-10"
Working Pressure	0.15-0.6 MPa	0.15-0.6 MPa
Water Temperature	5-50 °C	5-50 °C
Turbidity	< 5 FTU	< 5 FTU



Model	61104 (F64A1) 61204 (F64A2)	61204C (F64AC)	61206 (N64F)
Water Capacity	4.5 m³/h	4.5 m³/h	8 m³/h
Regeneration Type	Downflow	Downflow	Downflow
Handle material	Metal (A1) / Plastic (A2)	Plastic handwheel	Plastic handwheel
Mount Type	Top Mount	Top Mount, Side control	Top Mount
Inlet/Outlet	1"F	1"F	1.5"M
Drain	1/2"M	1/2"M	3/4"M
Brine Tank Connector	3/8"M	3/8"M	1/2"M
Base	2.5"-8NPSM	2.5"-8NPSM	4"-8UN
Riser Pipe	1.05" OD	1.05" OD	1.25"D-GB
Available Tank Size	6"-16"	6"-16"	6"-21"
Working Pressure	0.15-0.6 MPa	0.15-0.6 MPa	0.15-0.6 MPa
Water Temperature	5-50 °C	5-50 °C	5-50 °C
Turbidity	< 5 FTU	< 5 FTU	< 5 FTU



Model	61210 (N64D)	61215 (F77AS)	61240B (F112AS)
Water Capacity	10 m³/h	15 m³/h	40 m³/h
Regeneration Type	Downflow	Downflow	Downflow
Handle material	Plastic handwheel	Plastic handwheel	Plastic handwheel
Mount Type	Top/Side Mount	Top/Side Mount	Side Mount
Inlet/Outlet	2"M	2"M	DN65
Drain	1"M	2"M, connect 1.5"M current limiting parts	DN65
Brine Tank Connector	1/2"M	3/4"M	3/4"M
Base	4"-8UN	4"-8UN	-
Riser Pipe	1.5"D-GB	1.5"D-GB or 1.9"OD	Side mount, top and bottom distributor DN80
Available Tank Size	6"-21"	30"-36"	40"-48"
Working Pressure	0.15-0.6 MPa	0.2-0.6 MPa	0.2-0.6 MPa
Water Temperature	5-50 °C	5-50 °C	5-50 °C
Turbidity	< 5 FTU	< 2 FTU	< 5 FTU

Automatic Softening Control Valves

Structure & Performance Features

- LED display, long time power off indication and data will be saved for three days after power off.
- No hard water bypass in regeneration cycle (except F92 and F130).
- With signal output connector, remote handling connector which can receive passive signal.
- With interlock connector which can realize service simultaneously and regeneration one by one.
- N77, F95, F111 and F99 adopt ball valve for brine drawing and refill.
- Time clock regeneration option: by days or by hours; Meter valve regeneration option: Meter Delayed (A-01), Meter Immediate (A-02), Intelligent Meter Delayed (A-03), intelligent Meter Immediate (A-04).
- Up-flow control valve can set interval backwash times F-00, which can realize several times service and one time backwash.
- N77, F95 and F111 have two valve cores, one is for controlling inlet water and brine drawing, another is for outlet water.
- N77 and F95 with RS-485 port are optional.

Applications

- Residential Softener Systems (**F63/F65/F68/F69**).
- Softener for RO pretreatment System.
- Boiler Softening System, Ion exchange system.

Notes

- *The model with a "S" means the valve with manual operation function.*
- *N77,F95,F111 brine refilled while service, brine refilling controlled by electronic ball valve.*
- *F63, F65, F68 and F69 have a variety of appearances optional.*
- *N74B is optional which can be top or side-mounted.*





Model	63502 (F65B1) 63602 (F65B3)	63502B (F65G1) 63602B (F65G3)	73502 (F69A1) 73602 (F69A3)
Water Capacity	2 m ³ /h	2 m ³ /h	2 m ³ /h
Running Model	Time Clock (B1) / Meter (B3)	Time Clock (G1) / Meter (G3)	Time Clock (A1) / Meter (A3)
Regeneration Type	Downflow	Downflow	Upflow
Mount Type	Top Mount	Top Mount	Top Mount
Inlet/Outlet	3/4"F	3/4"F	3/4"F
Drain	1/2"M	1/2"M	1/2"M
Brine Tank Connector	3/8"M	3/8"M	3/8"M
Base	2.5"-8NPSM	2.5"-8NPSM	2.5"-8NPSM
Riser Pipe	1.05" OD	1.05" OD	1.05" OD
Available Tank Size	6"-10"	6"-10"	6"-10"
Working Pressure	0.15-0.6 MPa	0.15-0.6 MPa	0.15-0.6 MPa
Water Temperature	5-45 °C	5-45 °C	5-45 °C
Turbidity	< 5 FTU	< 5 FTU	< 2 FTU
Input Charge	AC 100V - 240V / 50-60 Hz	AC 100V - 240V / 50-60 Hz	AC 100V - 240V / 50-60 Hz
Output Charge	DC 12V/1.5A	DC 12V/1.5A	DC 12V/1.5A



Model	73502B (F69G1) 73602B (F69G3)	63503 (F117A1) 63603 (F117A3)	63504 (F63C1) 63604 (F63C3)
Water Capacity	2 m ³ /h	2 m ³ /h	4 m ³ /h
Running Model	Time Clock (G1) / Meter (G3)	Time Clock (A1) / Meter (A3)	Time Clock (C1) / Meter (C3)
Regeneration Type	Upflow	Downflow	Downflow
Mount Type	Top Mount	Top Mount	Top Mount
Inlet/Outlet	3/4"F	3/4"F	1"M
Drain	1/2"M	3/4"M	1/2"M
Brine Tank Connector	3/8"M	3/8"M	3/8"M
Base	2.5"-8NPSM	2.5"-8NPSM	2.5"-8NPSM
Riser Pipe	1.05" OD	1.05" OD	1.05" OD
Available Tank Size	6"-10"	6"-10"	6"-14"
Working Pressure	0.15-0.6 MPa	0.15-0.6 MPa	0.15-0.6 MPa
Water Temperature	5-50 °C	5-50 °C	5-50 °C
Turbidity	< 2 FTU	< 5 FTU	< 5 FTU
Input Charge	AC 100V - 240V / 50-60 Hz	AC 100V - 240V / 50-60 Hz	AC 100V - 240V / 50-60 Hz
Output Charge	DC 12V/1.5A	DC 12V/1.5A	DC 12V/1.5A



Model	63504B (F63G1) 63604B (F63G3)	63504C (F63I1) 63604C (F63I3)	63504S (F63B1) 63604S (F63B3)
Water Capacity	4 m³/h	4 m³/h	4 m³/h
Running Model	Time Clock (G1) / Meter (G3)	Time Clock (I1) / Meter (I3)	Time Clock (B1) / Meter (B3)
Regeneration Type	Downflow	Downflow	Downflow
Mount Type	Top Mount	Side Mount	Top Mount
Inlet/Outlet	1" M	1" M	1" M
Drain	1/2" M	1/2" M	1/2" M
Brine Tank Connector	3/8" M	3/8" M	3/8" M
Base	2.5"-8NPSM	2.5"-8NPSM	2.5"-8NPSM
Riser Pipe	1.05" OD	1.05" OD	1.05" OD
Available Tank Size	6"-14"	6"-14"	6"-14"
Working Pressure	0.15-0.6 MPa	0.15-0.6 MPa	0.15-0.6 MPa
Water Temperature	5-50 °C	5-50 °C	5-50 °C
Turbidity	< 5 FTU	< 5 FTU	< 5 FTU
Input Charge	AC 100V - 240V / 50-60 Hz	AC 100V - 240V / 50-60 Hz	AC 100V - 240V / 50-60 Hz
Output Charge	DC 12V/1.5A	DC 12V/1.5A	DC 12V/1.5A



Model	73504 (F68C1) 73604 (F68C3)	73504B (F68G1) 73604B (F68G3)	73504S (F68A1) 73604S (F68A3)
Water Capacity	4 m³/h	4 m³/h	4 m³/h
Running Model	Time Clock (C1) / Meter (C3)	Time Clock (G1) / Meter (G3)	Time Clock (A1) / Meter (A3)
Regeneration Type	Upflow	Upflow	Upflow
Mount Type	Top Mount	Top Mount	Top Mount with handwheel
Inlet/Outlet	1" M	1" M	1" M
Drain	1/2" M	1/2" M	1/2" M
Brine Tank Connector	3/8" M	3/8" M	3/8" M
Base	2.5"-8NPSM	2.5"-8NPSM	2.5"-8NPSM
Riser Pipe	1.05" OD	1.05" OD	1.05" OD
Available Tank Size	6"-14"	6"-14"	6"-14"
Working Pressure	0.15-0.6 MPa	0.15-0.6 MPa	0.15-0.6 MPa
Water Temperature	5-50 °C	5-50 °C	5-50 °C
Turbidity	< 2 FTU	< 2 FTU	< 2 FTU
Input Charge	AC 100V - 240V / 50-60 Hz	AC 100V - 240V / 50-60 Hz	AC 100V - 240V / 50-60 Hz
Output Charge	DC 12V/1.5A	DC 12V/1.5A	DC 12V/1.5A



Model	63505 (F116A1) 63605 (F116A3)	F116E3	F130A3	73505 (F92A1) 73605 (F92A3)
Water Capacity	4 m³/h	5 m³/h	5 m³/h	4.7 m³/h
Running Model	Time Clock (A1) / Meter (A3)	Meter	Meter	Time Clock (A1) / Meter (A3)
Regeneration Type	Downflow	Downflow	Downflow	Upflow
Mount Type	Top Mount	Top Mount	Top Mount	Top Mount
Inlet/Outlet	1"M	1"M	1"M	1"M
Drain	3/4"M	3/4"M	NPT 3/4"	3/4"M
Brine Tank Connector	3/8"M	3/8"M	3/8"M	3/8"M
Base	2.5"-8NPSM	2.5"-8NPSM	2.5"-8NPSM	2.5"-8NPSM
Riser Pipe	1.05" OD	1.05" OD	1"D-GB	1"D-GB
Available Tank Size	6"-14"	10"-20"	7"-22"	9"-16"
Working Pressure	0.15-0.6 MPa	0.15-0.6 MPa	0.15-0.6 MPa	0.15-0.6 MPa
Water Temperature	5-50 °C	5-50 °C	5-50 °C	5-50 °C
Turbidity	< 5 FTU	< 5 FTU	< 5 FTU	< 2 FTU
Input Charge	AC 100V - 240V / 50-60 Hz	AC 100V - 240V / 50-60 Hz	AC 100V - 240V / 50-60 Hz	AC 100V - 240V / 50-60 Hz
Output Charge	DC 12V/1.5A	DC 12V/1.5A	DC 12V/2A	DC 12V/2.0A



Model	73605E (F92E3)	63508 (F133A1) 63608 (F133A3)	63510 (N74A1) 63610 (N74A3)	63510B (N74B1) 63610B (N74B3)
Water Capacity	5 m³/h	8 m³/h	10 m³/h	10 m³/h
Running Model	Meter	Time Clock (A1) / Meter (A3)	Time Clock (A1) / Meter (A3)	Time Clock (B1) / Meter (B3)
Regeneration Type	Upflow	Downflow	Downflow	Downflow
Mount Type	Top Mount	Top Mount	Top Mount	Top/Side Mount
Inlet/Outlet	1"M	1.5"M	2"M	2"M
Drain	NPT 3/4"	3/4"M	1"M	1"M
Brine Tank Connector	3/8"M	1/2"M	1/2"M	1/2"M
Base	2.5"-8NPSM	4"-8UN	4"-8UN	4"-8UN
Riser Pipe	1"D-GB	1.25"D-GB or 1.66" OD	1.5"D-GB or 1.9" OD	1.5"D-GB or 1.9" OD
Available Tank Size	7"-22"	16"-18"	20"-21"	20"-21"
Working Pressure	0.15-0.6 MPa	0.2-0.6 MPa	0.2-0.6 MPa	0.2-0.6 MPa
Water Temperature	5-50 °C	5-50 °C	5-45 °C	5-45 °C
Turbidity	< 2 FTU	< 5 FTU	< 5 FTU	< 5 FTU
Input Charge	AC 100V - 240V / 50-60 Hz	AC 100V - 240V / 50-60 Hz	AC 100V - 240V / 50-60 Hz	AC 100V - 240V / 50-60 Hz
Output Charge	DC 12V/1.5A	DC 24V/1.5A	DC 24V/1.5A	DC 24V/1.5A



Model	63515 (F99A1) 63615 (F99A3)	73515 (F99D1) 73615 (F99D3)	63518 (N77A1) 63618 (N77A3)	63520 (F95A1) 63620 (F95A3)
Water Capacity	15 m³/h	15 m³/h	18 m³/h	21.6 m³/h
Running Model	Time Clock (A1) / Meter (A3)	Time Clock (D1) / Meter (D3)	Time Clock (A1) / Meter (A3)	Time Clock (A1) / Meter (A3)
Regeneration Type	Downflow	Upflow	Downflow	Downflow
Mount Type	Top/Side Mount	Top/Side Mount	Top/Side Mount	Side Mount
Inlet/Outlet	2" M	2" M	2" M	2" M
Drain	1.5" M	1.5" M	1.5" M	1.5" M
Brine Tank Connector	3/4" M	3/4" M	3/4" M	3/4" M
Base	4"-8UN	4"-8UN	4"-8UN	-
Riser Pipe	1.5"D-GB or 1.9" OD	1.5"D-GB or 1.9" OD	1.5"D-GB or 1.9" OD	Side mount, top and bottom distributor 2" M
Available Tank Size	30"	30"	30"-36"	36"-40"
Working Pressure	0.2-0.6 MPa	0.2-0.6 MPa	0.2-0.6 MPa	0.2-0.6 MPa
Water Temperature	5-50 °C	5-50 °C	5-50 °C	5-50 °C
Turbidity	< 5 FTU	< 2 FTU	< 5 FTU	< 5 FTU
Input Charge	AC 100V - 240V / 50-60 Hz	AC 100V - 240V / 50-60 Hz	AC 100V - 240V / 50-60 Hz	AC 100V - 240V / 50-60 Hz
Output Charge	DC 24V/1.5A	DC 24V/1.5A	DC 24V/1.5A	DC 24V/1.5A



Model	63520T (F111A1) 63620T (F111A3)	73520 (F95D1) 73620 (F95D3)	63540B (F112A1) 63640B (F112A3)	63550 (F96A1) 63650 (F96A3)
Water Capacity	21.1 m³/h	21.6 m³/h	40 m³/h	50 m³/h
Running Model	Time Clock (A1) / Meter (A3)	Time Clock (D1) / Meter (D3)	Time Clock (A1) / Meter (A3)	Time Clock (A1) / Meter (A3)
Regeneration Type	Downflow	Upflow	Downflow	Downflow
Mount Type	Top Mount	Side Mount	Side Mount	Side Mount
Inlet/Outlet	2" M	2" M	DN65	DN80
Drain	1.5" M	1.5" M	DN65	DN80
Brine Tank Connector	3/4" M	3/4" M	3/4" M	3/4" M
Base	4"-8UN	-	-	-
Riser Pipe	2"D-GB	Side mount, top and bottom distributor 2" M	Side mount, top and bottom distributor DN80	Side mount, top and bottom distributor DN100
Available Tank Size	36"-40"	36"-40"	40"-48"	60"-63"
Working Pressure	0.2-0.6 MPa	0.2-0.6 MPa	0.2-0.6 MPa	0.2-0.6 MPa
Water Temperature	5-50 °C	5-50 °C	5-50 °C	5-50 °C
Turbidity	< 5 FTU	< 2 FTU	< 5 FTU	< 5 FTU
Input Charge	AC 100V - 240V / 50-60 Hz	AC 100V - 240V / 50-60 Hz	AC 100V - 240V / 50-60 Hz	AC 100V - 240V / 50-60 Hz
Output Charge	DC 24V/1.5A	DC 24V/1.5A	DC 24V/4.0A	DC 24V/4.0A

Continuous Water Supply Control Valves

One in Service One Standby – One Valve on Duplex Tank

To satisfy markets continuous water supply requirements, Runxin develop the first control valve, which can control two tanks one time to achieve one in service and one standby and guarantee continuous water supply.

This system contains one control valve and two tanks, it can achieve downflow or upflow regeneration through switch program. Besides, it adopts top or side mount method according to different output and tank structure.

This structure can achieve max. output 3.5 m³/h, 6 m³/h, 10 m³/h.



Technical Performance

Item		Requirements
Working Condition	Water Pressure	0.2–0.6 MPa
	Water Temperature	5–50 °C
Working Environment	Environment Temperature	5–50 °C
	Relative Humidity	≤95% (25 °C)
	Electrical Facility	AC 100V – 240V / 50–60 Hz
Inlet Water Quality	Water Turbidity	Upflow regeneration < 2FTU Downflow regeneration < 5FTU
	Water Hardness	First Grade Na+: 93610/93606 < 15 mmol/L 17610/17606 < 6.5 mmol/L
	Free Chlorine	< 0.1 mg/L
	Iron ²⁺	< 0.3 mg/L
	CODMn	< 2 mg/L (O ₂)

Notes

- First grade Na refers to First grade NA ion exchanger
- When the turbidity exceeds the working condition, a filter should be installed on the inlet of control valves.
- When the water hardness exceeds the working condition, the hardness of treated water can not meet the needed requirements (for example 0.03 mmol/L for boil water), you should adopt secondary softening.



17603	17603 (F73)	17606 (F98A)	17606T (F137)	17610 (F88A)	17610T (F135A)
Water Capacity	3.5 m³/h	6 m³/h	6 m³/h	10 m³/h	10 m³/h
Running Model	Meter	Meter	Meter	Meter	Meter
Regeneration Type	Upflow/Downflow	Upflow	Downflow	Upflow	Downflow
Mount Type	Top Mount	Side Mount	Top Mount	Side Mount	Top Mount
Inlet/Outlet	1"M	1"M	1"M	1.5"M	1.5"M
Drain	1/2"M	3/4"M	3/4"M	1"M	3/4"M
Brine Tank Connector	3/8"M	1/2"M	1/2"M	1/2"M	1/2"M
Base	2.5"-8NPSM	-	4"-8UN	-	4"-8UN
Riser Pipe	1.05" OD	Side mount, top and bottom distributor 1"M	1.5"D-GB (32 mm OD)	Side mount, top and bottom distributor 1.5"M	1.5"D-GB or 1.9"OD
Available Tank Size	12"-14"	20"-21"	16"-24"	20"-30"	20"-30"
Turbidity	< 2 FTU or < 5 FTU	< 2 FTU	< 5 FTU	< 2 FTU	< 5 FTU

One in Service One Standby – Floating Bed



Model	93606 (F98C)	93610 (F88C)
Water Capacity	6 m³/h	10 m³/h
Running Model	Meter	Meter
Regeneration Type	Upflow	Upflow
Mount Type	Side Mount	Side Mount
Inlet/Outlet	1"M	1.5"M
Drain	3/4"M	1"M
Brine Tank Connector	1/2"M	1/2"M
Base	-	-
Riser Pipe	Side mount, top and bottom distributor 1"M	Side mount, top and bottom distributor 1.5"M
Available Tank Size	14"-16"	20"-21"
Turbidity	< 2 FTU	< 2 FTU

One in Service One Standby – Two Valve and Two Tank

5–6 m³/h

- Suitable for 5-6 m³/h Continuous Water Supplying
- Two F92A3/F130A3 and DN25 Three-way Electronic Ball Valve (Four Core Plug)
- Two F92A3/F130A3 are interlocked as one system, and set C-02 (a connection for one in service one standby softening system)



10–20 m³/h

- Suitable for 10-20 m³/h Continuous Water Supplying
- Two N74A3/F99A3/N77A3/F95A3/F111A3 and F80
- Two valves are interlocked as one system, and set the system to A-02 and b-01; Connect the signal output connector with the control wire of F80.
- When the flow of working valve reduces to 0, the control valve regenerates F80 switches by the signal outlet connector controlling, the other valve turns to service.
- If the other valve is in regeneration, because of the function of interlock, the working valve still in service.

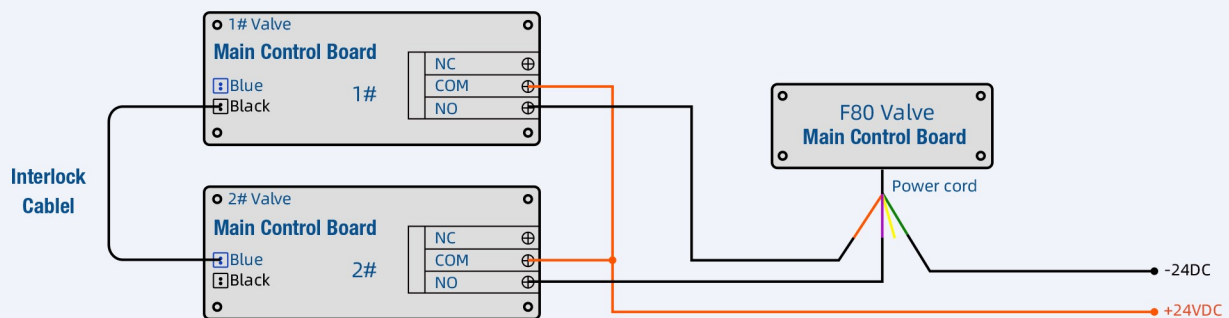

40–50 m³/h

- Suitable for 40–50 m³/h Continuous Water Supplying
- Two F112A3/F96A3 and Two DN25 Electronic Ball Valves
- Two valves are connected to signal line of one in service and one standby system (interlock wire), and set the system to C-02 (One in Service One Standby System).
- Ordinary F112A3/F96A3 needs to replace brine draw copper tube and install DN25 ball valve with it.
- Continuous water supplying, one valve in service, the other valve standby.



Two in Service One Standby

- One valve controls three tanks, two tanks supply with softened water in series, the other tank standby to achieve water supply continuously.
- When service finishes, the first grade in series turns to regenerate, the second grade turns to the first grade and supplies with softened water together with the standby tank as the second grade in series, which greatly improves the resin efficiency, saves water and salt.
- Regeneration tank keeps standby after switch and starts fast rinse before service.
- Only need one brine tank.
- It adopts hermetic head faces structure with ceramic sealing, reliable and duration.
- Up-flow or down-flow regeneration is optional by program.
- Raw water or softened water for regeneration is optional by changing the moving disk.
- Remove one tank to make the system as one in service one standby system.
- There is always two tanks in service in series which could treat the raw water with high hardness. It has backwash function, which could be used in high turbidity application which floating bed system can't be used.
- Suitable for treat high hardness water and continuous water supplying application

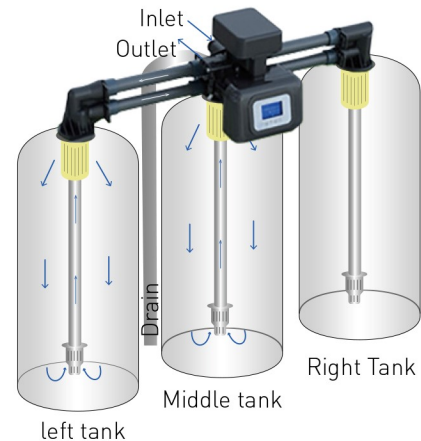

Model	18604A (F118A) 18604B (F118B)	18601B (F120B)
Water Capacity	4 m³/h	1.5 m³/h
Running Model	Meter	Meter
Regeneration Type	Downflow/Upflow	Downflow/Upflow
Mount Type	Top Mount	Top Mount
Inlet/Outlet	G1"	G3/4"
Drain	NPT 3/4"	NPT 3/4"
Brine Tank Connector	G3/8"	G3/8"
Base	3 × 2.5"-8NPSM	3 × 2.5"-8NPSM
Riser Pipe	3 × 1.05" OD	3 × 1.05" OD
Available Tank Size	10"-18"	10"-12"
Working Pressure	0.15-0.6 MPa	0.15-0.6 MPa
Water Temperature	5-50 °C	5-50 °C
Turbidity	Downflow < 5 FTU Upflow < 2 FTU	Downflow < 5 FTU Upflow < 2 FTU
Input Charge	AC 100V – 240V / 50-60 Hz	AC 100V – 240V / 50-60 Hz
Transformer Output	DC 12V/2A	DC 12V/2A

Note: F118A raw water regeneration mode; F118B soft water regeneration mode.

Softener Flow Chart

Softening

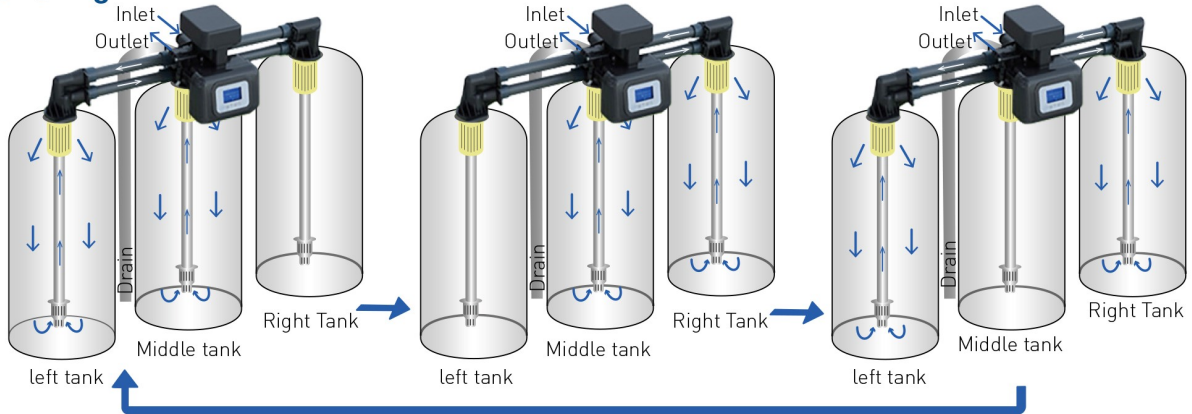

Left tank + middle tank in serial service, right tank regeneration and standby

Middle tank + right tank in serial service, left tank regeneration and standby

Right tank + left tank in serial service, middle tank regeneration and standby

Regeneration

It takes left tank and middle tank in serial service and right tank regeneration as sample.

www.redawatergroup.com

Left tank + middle tank in serial service, right tank backwash

Left tank + middle tank in serial service, right tank upflow brine draw

Left tank + middle tank in serial service, right tank downflow brine draw

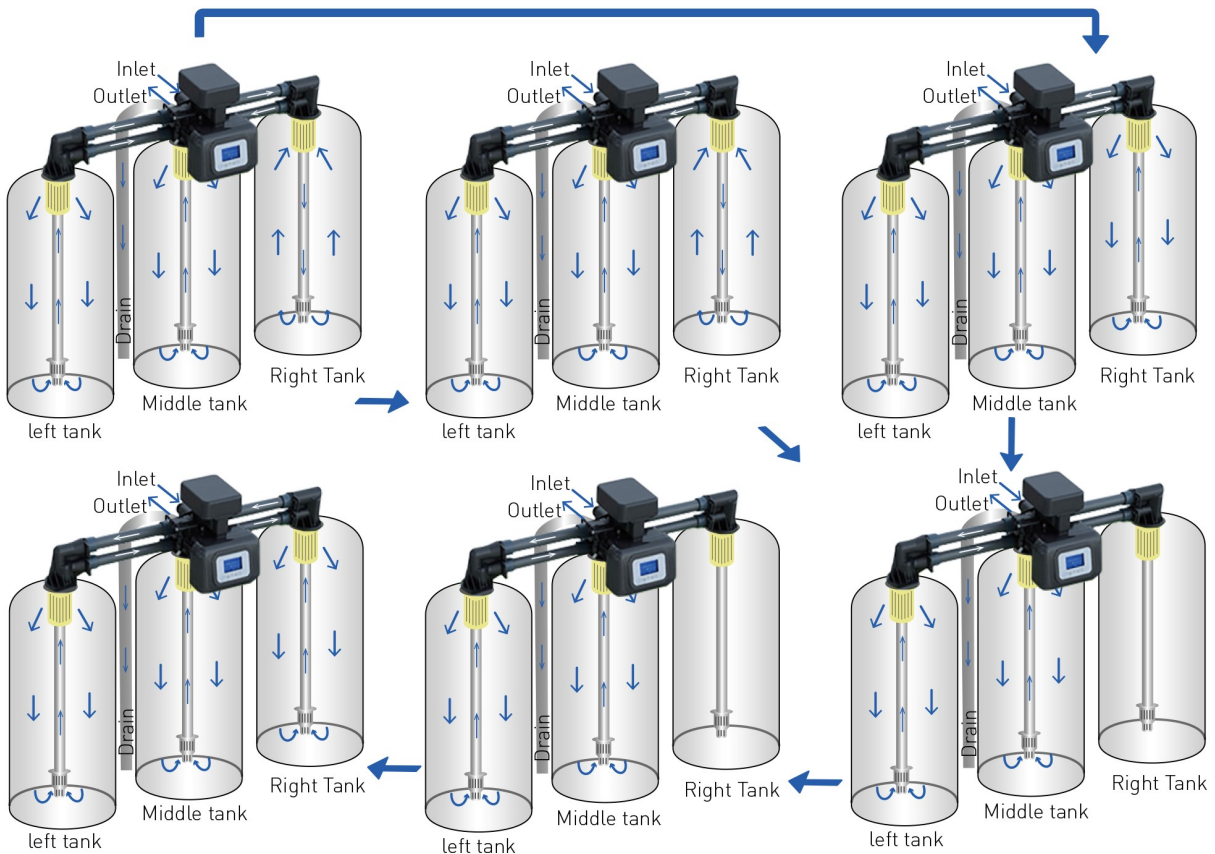

Left tank + middle tank in serial service, right tank fast rinse

Left tank + middle tank in serial service, right tank standby

Left tank + middle tank in serial service, right tank brine refill

P Series

Structure & Performance Features

- Locate by optocoupler, more stable performance. F63P, F67P and F68P adopt the same locating board, while F65P, F69P and F71P use the same locating board. They all use the same main control board.
- Hermetic head faces structure, no hard water bypass during regeneration cycle.
- When power on, program run one cycle then locate at the previous position.
- Cheaper and simpler.
- Indicator display



Model	54502 (F71P1)	64502 (F65P1) 64602 (F65P3)	74502 (F69P1) 74602 (F69P3)	74502Y (F69P1Y)
Water Capacity	2 m³/h	2 m³/h	2 m³/h	2 m³/h
Running Model	Time Clock	Time Clock (P1) / Meter (P3)	Time Clock (P1) / Meter (P3)	Time Clock
Regeneration Type	-	Downflow	Upflow	Upflow
Mount Type	Top Mount	Top Mount	Top Mount	Top Mount
Inlet/Outlet	3/4"M	3/4"M	3/4"F	3/4"M
Drain	3/4"M	1/2"M	1/2"M	1/2"M
Brine Tank Connector	-	3/8"M	3/8"M	3/8"M
Base	2.5"-8NPSM	2.5"-8NPSM	2.5"-8NPSM	2.5"-8NPSM
Riser Pipe	1.05" OD	1.05" OD	1.05" OD	1.05" OD
Available Tank Size	6"-10"	6"-10"	6"-10"	6"-10"
Working Pressure	0.15-0.6 MPa	0.15-0.6 MPa	0.15-0.6 MPa	0.15-0.6 MPa
Water Temperature	5-50 °C	5-50 °C	5-50 °C	5-50 °C
Turbidity	< 20 FTU	< 5 FTU	< 2 FTU	< 2 FTU
Input Charge	AC 100V - 240V / 50-60 Hz	AC 100V - 240V / 50-60 Hz	AC 100V - 240V / 50-60 Hz	AC 100V - 240V / 50-60 Hz
Output Charge	DC 12V/1.5A	DC 12V/1.5A	DC 12V/1.5A	DC 12V/1.5A



Model	54504 (F67P1)	64504 (F63P1) 64604 (F63P3)	74504 (F68P1) 74604 (F68P3)	74504Y (F68P1Y)
Water Capacity	4 m³/h	4 m³/h	4 m³/h	4 m³/h
Running Model	Time Clock	Time Clock (P1) / Meter (P3)	Time Clock (P1) / Meter (P3)	Time Clock
Regeneration Type	-	Downflow	Upflow	Upflow
Mount Type	Top Mount	Top Mount	Top Mount	Top Mount
Inlet/Outlet	1"F	1"M	1"M	1"M
Drain	1"F	1/2"M	1/2"M	1/2"M
Brine Tank Connector	-	3/8"M	3/8"M	3/8"M
Base	2.5"-8NPSM	2.5"-8NPSM	2.5"-8NPSM	2.5"-8NPSM
Riser Pipe	1.05" OD	1.05" OD	1.05" OD	1.05" OD
Available Tank Size	6"-14"	6"-14"	6"-14"	6"-14"
Working Pressure	0.15-0.6 MPa	0.15-0.6 MPa	0.15-0.6 MPa	0.15-0.6 MPa
Water Temperature	5-50 °C	5-50 °C	5-50 °C	5-50 °C
Turbidity	< 20 FTU	< 5 FTU	< 2 FTU	< 2 FTU
Input Charge	AC 100V - 240V / 50-60 Hz	AC 100V - 240V / 50-60 Hz	AC 100V - 240V / 50-60 Hz	AC 100V - 240V / 50-60 Hz
Output Charge	DC 12V/1.5A	DC 12V/1.5A	DC 12V/1.5A	DC 12V/1.5A

Q Series

Structure & Performance Features

- Integrate main board and display board on one board.
- Four digital display.
- With interlock connector and signal output connector.
- Parameters will be saved after power off.

Application

- Residential softener or filter system.
- Boiler softener, Ion-exchange equipment.



Model	55502 (F71Q1) 55602 (F71Q3)	75502 (F69Q1) 75602 (F69Q3)	65503 (F117Q1) 65603 (F117Q3)	55504 (F67Q1) 55604 (F67Q3)
Water Capacity	2 m³/h	2 m³/h	2 m³/h	4 m³/h
Running Model	Time Clock (Q1) / Meter (Q3)	Time Clock (Q1) / Meter (Q3)	Time Clock (Q1) / Meter (Q3)	Time Clock (Q1) / Meter (Q3)
Regeneration Type	-	Upflow	Downflow	-
Mount Type	Top Mount	Top Mount	Top Mount	Top Mount
Inlet/Outlet	3/4"M	3/4"M	3/4"F	1"F
Drain	3/4"M	3/4"NPT	3/4"NPT	1"F
Brine Tank Connector	-	3/8"M	3/8"M	-
Base	2.5"-8NPSM	2.5"-8NPSM	2.5"-8NPSM	2.5"-8NPSM
Riser Pipe	1.05" OD	1.05" OD	1.05" OD	1.05" OD
Available Tank Size	6"-10"	6"-10"	6"-10"	6"-10"
Working Pressure	0.15-0.6 MPa	0.15-0.6 MPa	0.15-0.6 MPa	0.15-0.6 MPa
Water Temperature	5-50 °C	5-50 °C	5-50 °C	5-45 °C
Turbidity	< 20 FTU	< 2 FTU	< 5 FTU	< 20 FTU
Input Charge	AC 100V - 240V / 50-60 Hz	AC 100V - 240V / 50-60 Hz	AC 100V - 240V / 50-60 Hz	AC 100V - 240V / 50-60 Hz
Output Charge	DC 12V/1.0A	DC 12V/1.0A	DC 12V/1.0A	DC 12V/1.5A



Model	75504 (F68Q1) 75604 (F68Q3)	65505 (F116Q1) 65605 (F116Q3)	65510 (N74Q1) 65610 (N74Q3)	55510 (N75Q1)
Water Capacity	4 m³/h	4 m³/h	10 m³/h	10 m³ /h
Running Model	Time Clock (Q1) / Meter (Q3)	Time Clock (Q1) / Meter (Q3)	Time Clock (Q1) / Meter (Q3)	Time clock
Regeneration Type	Upflow	Downflow	Downflow	-
Mount Type	Top Mount	Top Mount	Top Mount	Top Mount
Inlet/Outlet	1"M	1"M	2"M	2"M
Drain	3/4"NPT	3/4"NPT	1"M	2"M
Brine Tank Connector	3/8"M	3/8"M	1/2"M	-
Base	2.5"-8NPSM	2.5"-8NPSM	4"-8UN	4"-8UN
Riser Pipe	1.05" OD	1.05" OD	1.5"D-GB or 1.9" OD	1.5"D-GB or 1.9" OD
Available Tank Size	6"-14"	6"-14"	20"-30"	16"-24"
Working Pressure	0.15-0.6 MPa	0.15-0.6 MPa	0.2-0.6 MPa	0.15-0.6 MPa
Water Temperature	5-45 °C	5-45 °C	5-50 °C	5-50 °C
Turbidity	< 2 FTU	< 5FTU	< 5 FTU	< 20 FTU
Input Charge	AC 100V - 240V / 50-60 Hz	AC 100V - 240V / 50-60 Hz	AC 100V - 240V / 50-60 Hz	AC 100V - 240V / 50-60 Hz
Output Charge	DC 12V/1.5A	DC 12V/1.5A	DC 24V/1.5A	DC 24V/1.5A

Floating Bed

Structure & Performance Features

- Hermetic head faces structure (F112 has piston structure)
- For F88, F98 valve, one valve on twin tanks, one in service, the other standby.
- F83, F77CS and F112CS adopt hard water for regeneration, others adopt soft water for regeneration.
- Adopt the working process: up-flow service – brine draw – brine refill – fast rinse.
- Suitable for high hardness (less than 15 mmo/L) water treatment applications.



Model	93504 (F83A1) 93604 (F83A3)	93606 (F98C)	93610 (F88C)	91215 (F77CS)
Water Capacity	4 m³/h	6 m³/h	10 m³/h	15 m³/h
Running Model	Time Clock (A1) / Meter (A3)	Meter	Meter	Manual Softener
Regeneration Type	Upflow	Upflow	Upflow	Upflow
Mount Type	Top Mount	Side Mount	Side Mount	Top/Side Mount
Inlet/Outlet	1"M	1"M	1.5"M	2"M
Drain	1/2"M	3/4"M	1"M	2"M
Brine Tank Connector	3/8"M	1/2"M	1/2"M	3/4"M
Base	2.5"-8NPSM	-	-	4"-8UN
Riser Pipe	1.05" OD	Side mount, top and bottom distributor 1"M	Side mount, top and bottom distributor 1.5"M	1.5"D-GB
Available Tank Size	10"-14"	14"-16"	20"-21"	20"-30"
Working Pressure	0.15-0.6 MPa	0.2-0.6 MPa	0.2-0.6 MPa	0.2-0.6 MPa
Water Temperature	5-45 °C	5-50 °C	5-50 °C	5-50 °C
Turbidity	< 2 FTU	< 2 FTU	< 2 FTU	< 2 FTU
Input Charge	AC 100V - 240V / 50-60 Hz	AC 100V - 240V / 50-60 Hz	AC 100V - 240V / 50-60 Hz	-
Output Charge	DC 12V/1.5A	DC 24V/1.5 [^]	DC 24V/1.5A	-



Model	93520 (F95C1) 93620 (F95C3)	91240B (F112CS)	93640B (F112C3)
Water Capacity	20.5 m³/h	40 m³/h	40 m³/h
Running Model	Time Clock (C1) / Meter (C3)	Manual Softener	Meter
Regeneration Type	Upflow	Upflow	Upflow
Mount Type	Side Mount	Side Mount	Side Mount
Inlet/Outlet	2"M	DN65	DN65
Drain	1.5"M	DN65	DN65
Brine Tank Connector	3/4"M	3/4"M	3/4"M
Base	-	-	-
Riser Pipe	Side mount, top and bottom distributor 2"M	Side mount, top and bottom distributor DN80	Side mount, top and bottom distributor DN80
Available Tank Size	20"-30"	36"-40"	36"-40"
Working Pressure	0.2-0.6 MPa	0.2-0.6 MPa	0.2-0.6 MPa
Water Temperature	5-50 °C	5-50 °C	5-50 °C
Turbidity	< 2 FTU	< 2 FTU	< 2 FTU
Input Charge	AC 100V - 240V / 50-60 Hz	-	AC 100V - 240V / 50-60 Hz
Output Charge	DC 24V/1.5A	-	DC 24V/1.5A

Residential D Series

Structure & Performance Features

- LCD display, intuitional and convenient.
- Indication of long time power off, data saved after power off (saved for three days.)
- Up-flow valve can set interval backwash times F-00, which can realize several times service and one time backwash.
- Downflow or Upflow option can be set in the program, and also can mix hard water to the system if required not too soft water.
- With disinfection connector which can be connected with disinfection device to electrolyze brine during regeneration to disinfect.
- D series valve has foreground and background modes to prevent incorrect operation.
- F105 and F97 use soft water for brine refilling, both UF and DF option, have vacation mode and dry brine mode.
- F105 and F79 has the leakage protection function; F105 has the function of proportinally brine draw and brine refill based on the percentage of real capacity

Application

- Residential Softener or the Whole House Water Softener.
- RO Pre-treatment Softener.



Model	52502H (F71D1)	62502 (F65D1) 62602 (F65D3)	72502 (F69D1) 72602 (F69D3)	82602 (F79A-LCD, LED are also available.)	82602 (F79B-LCD, LED are also available.)
Water Capacity	2 m ³ /h	2 m ³ /h	2 m ³ /h	2 m ³ /h	2 m ³ /h
Running Model	Time Clock	Time Clock (D1) / Meter (D3)	Time Clock (D1) / Meter (D3)	Meter	Meter
Regeneration Type	-	Downflow	Upflow	Downflow/Upflow	Downflow/Upflow
Mount Type	Top Mount	Top Mount	Top Mount	Top Mount	Top Mount
Inlet/Outlet	3/4"M	3/4"F	3/4"F	3/4"M	3/4"M
Drain	3/4"M	1/2"M	1/2"M	1/2"M	1/2"M
Brine Tank Connector	-	3/8"M	3/8"M	3/8"M	3/8"M
Base	2.5"-8NPSM	2.5"-8NPSM	2.5"-8NPSM	2.5"-8NPSM	2.5"-8NPSM
Riser Pipe	1.05" OD	1.05" OD	1.05" OD	1.05" OD	1.05" OD
Available Tank Size	6"-10"	6"-10"	6"-10"	6"-10"	6"-10"
Working Pressure	0.15-0.6 MPa	0.15-0.6 MPa	0.15-0.6 MPa	0.15-0.6 MPa	0.15-0.6 MPa
Water Temperature	5-50 °C	5-50 °C	5-50 °C	5-50 °C	5-50 °C
Turbidity	< 20 FTU	< 5 FTU	< 2 FTU	< 5 FTU	< 5 FTU
Input Charge	AC 100V - 240V / 50-60 Hz	AC 100V - 240V / 50-60 Hz	AC 100V - 240V / 50-60 Hz	AC 100V - 240V / 50-60 Hz	AC 100V - 240V / 50-60 Hz
Output Charge	DC 12V/1.5A	DC 12V/1.5A	DC 12V/1.5A	DC 12V/1.5A	DC 12V/1.5A



Model	82602E (F105A3)	82603FD (F136BHW)	82603E (F97B3)	52504H (F67D1)
Water Capacity	2 m³/h	3 m³/h	4 m³/h	4 m³/h
Running Model	Meter	Meter	Meter	Time Clock
Regeneration Type	Downflow/Upflow	Downflow/Upflow	Downflow/Upflow	-
Mount Type	Top Mount	Top Mount	Top Mount	Top Mount
Inlet/Outlet	3/4"M	G1"	3/4"M	1"M
Drain	1/2"M	NPT 3/4"	1/2"M	1"M
Brine Tank Connector	3/8"M	3/8"M	3/8"M	-
Base	2.5"-8NPSM	2.5"-8NPSM	2.5"-8NPSM	2.5"-8NPSM
Riser Pipe	1.05" OD	1.05" OD	1.05" OD	1.05" OD
Available Tank Size	6"-10"	6"-12"	6"-18"	6" to 14"
Working Pressure	0.15-0.6 MPa	0.15-0.6 MPa	0.15-0.6 MPa	0.15-0.6 MPa
Water Temperature	5-50 °C	5-50 °C	5-50 °C	5-50 °C
Turbidity	Downflow < 5 FTU, Upflow < 2 FTU	Downflow < 5 FTU Upflow < 2 FTU	Downflow < 5 FTU Upflow < 2 FTU	< 20 FTU
Input Charge	AC 100V - 240V / 50-60 Hz	AC 100V - 240V / 50-60 Hz	AC 100V - 240V / 50-60 Hz	AC 100V - 240V / 50-60 Hz
Output Charge	DC 12V/1.5A	DC 12V/1.5A	DC 12V/2A	DC 12V/1.5A



Model	62504 (F63D1) 62604 (F63D3)	72504 (F68D1) 72604 (F68D3)	82604 (F82A-LCD) * 82604B (F82B-LCD)	82604 (F82A-LED) * 82604B (F82B-LED)
Water Capacity	4 m³/h	4 m³/h	4 m³/h	4 m³/h
Running Model	Time Clock (D1) / Meter (D3)	Time Clock (D1) / Meter (D3)	Meter	Meter
Regeneration Type	Downflow	Upflow	Downflow/Upflow	Downflow/Upflow
Mount Type	Top Mount	Top Mount	Top Mount	Top Mount
Inlet/Outlet	1"M	1"M	1"M	1"M
Drain	1/2"M	1/2"M	1/2"M	1/2"M
Brine Tank Connector	3/8"M	3/8"M	3/8"M	3/8"M
Base	2.5"-8NPSM	2.5"-8NPSM	2.5"-8NPSM	2.5"-8NPSM
Riser Pipe	1.05" OD	1.05" OD	1.05" OD	1.05" OD
Available Tank Size	6" to 18"	6" to 18"	6" to 18"	6" to 18"
Working Pressure	0.15-0.6 MPa	0.15-0.6 MPa	0.15-0.6 MPa	0.15-0.6 MPa
Water Temperature	5-50 °C	5-50 °C	5-50 °C	5-50 °C
Turbidity	< 5 FTU	< 2 FTU	< 5 FTU	< 5 FTU
Input Charge	AC 100V - 240V / 50-60 Hz	AC 100V - 240V / 50-60 Hz	AC 100V - 240V / 50-60 Hz	AC 100V - 240V / 50-60 Hz
Output Charge	DC 12V/1.5A	DC 12V/1.5A	DC 12V/1.5A	DC 12V/1.5A

*Note: A: No raw water passes valve when regeneration; B:With raw water passes valve when regeneration.

Special Application Control Valves

F107&F107C

Iron-Manganese Removal Device

It is composed of aeration device and multiport control valves. The device adopts impeller stirring plus dropping create aeration process.

And automatic air release valve constantly drain off the air and carbon dioxide in water.

Combining with automatic filter control valves, this device can help to remove the iron or manganese from the water which has a big containing, as a pre-treatment device before industrial softening system or demineralization system.



Model	F107	F107C
Water Capacity	2 m ³ /h	10 m ³ /h
Outlet Water Iron Content	Iron content < 0.3 mg/L	Iron content < 0.3 mg/L
Outlet Water Manganese Content	< 0.1 mg/L	< 0.1 mg/L
Outlet Water Turbidity	< 5 mg/L	< 5 mg/L
Inlet Water Iron Content	Iron content < 20 mg/L	Iron content < 20 mg/L
Inlet Water Manganese Content	< 3 mg/L	< 3 mg/L
Inlet Water Turbidity	< 15 mg/L	< 15 mg/L
Alkalinity	< 2 mg/L	< 2 mg/L
pH Value	6.8-9	6.8-9
Water Temperature	6-10 °C	6-10 °C

Control Valve for Achieving One Valve on Duplex Tanks and Working in Series

- Patented design: one valve on duplex tanks, working in series;
- Under 0.1 MPa pressure drop, the flow rate is 4 m³/h;
- Filter + softening duplex tanks work in series system;
- Ozone + filter duplex tanks for iron and manganese removal system works in series;
- Duplex tanks softener system works in series;
- Three or more tanks can be realized in series.



Model	12504 (F142A1)	12604 (F142A3)	12504 (F142B1)	12604 (F142B3)
Water Capacity	4 m ³ /h	4 m ³ /h	4 m ³ /h	4 m ³ /h
Running Model	Time Clock	Meter	Time Clock	Meter
Regeneration Type	Downflow, brine drawing	Downflow, brine drawing	Downflow, Ozone drawing	Downflow, Ozone drawing
Mount Type	Top Mount	Top Mount	Top Mount	Top Mount
Inlet/Outlet	G1"	G1"	G1"	G1"
Drain	NPT 3/4"	NPT 3/4"	NPT 3/4"	NPT 3/4"
Brine Tank Connector	G3/8"	G3/8"	G3/8"	G3/8"
Base	2.5"-8NPSM	2.5"-8NPSM	2.5"-8NPSM	2.5"-8NPSM
Riser Pipe	1"D-GB	1"D-GB	1"D-GB	1"D-GB
Turbidity	< 5 FTU	< 5 FTU	< 5 FTU	< 5 FTU
Transformer Input	AC 100V - 240V / 50-60 Hz	AC 100V - 240V / 50-60 Hz	AC 100V - 240V / 50-60 Hz	AC 100V - 240V / 50-60 Hz
Transformer Output	DC 12V/1.5A	DC 12V/1.5A	DC 12V/1.5A	DC 12V/1.5A

Bypass Valves Series



Model	41104 (F70A)	41102 (F70B)	41204 (F70C)
Water Capacity	4 m ³ /h	2 m ³ /h	4 m ³ /h
Inlet	1"M	3/4"M	1"M
Outlet	1"M	3/4"M	1"M
Valve Size	1"F	3/4"M	1"F
Inlet & Outlet Distance	50 mm	65/70 mm	50 mm
Working Pressure	0.6 MPa	0.6 MPa	0.6 MPa
Water Temperature	5–50 °C	5–50 °C	5–50 °C
Remark	Suited for F63/F68 Valve	Suited for F65/F69 Valve	Suited for F63/F68/F82 Valve



Model	41202 (F70D)	41206 (F70F)	41205 (F70G)
Water Capacity	2 m ³ /h	6 m ³ /h	5 m ³ /h
Inlet	3/4"M	1"M	NPT 3/4"M or 1"M or NPT 1"M
Outlet	3/4"M	1"M	NPT 3/4"M or 1"M or NPT 1"M
Valve Size	3/4"M	NPT 1" or 1"M	3/4"M or 1"M or NPT 1"M
Inlet & Outlet Distance	50 mm	50 mm	50 mm
Working Pressure	0.6 MPa	0.6 MPa	0.6 MPa
Water Temperature	5–50 °C	5–50 °C	5–50 °C
Remark	Suited for F79 Valve	Suited for F92/F97 Valve	Suited for F63/F68/F79/F82/F105/F136 Valve



Model	41302 (F70H)	41103 (F70I)	41302Y (F70HYL)
Water Capacity	2 m ³ /h	3 m ³ /h	2 m ³ /h
Inlet	3/4"M	1"M	3/4"M
Outlet	3/4"M	1"M	3/4"M
Valve Size	3/4"M	1"M	3/4"M
Inlet & Outlet Distance	50 mm	50 mm	50 mm
Working Pressure	0.6 MPa	0.6 MPa	0.6 MPa
Water Temperature	5–50 °C	5–50 °C	5–50 °C
Remark	Suited for F67N/F122 Valve	Suited for F79BD Valve	Suited for F105/F126 Valve

Appendix-1

Water Capacity	Filter		Manual Softener	Automatic Downflow		Automatic Upflow		Bypass Valve		
	Manual	Automatic		Downflow/Upflow	Time Clock Type	Meter Type	Time Clock Type	Meter Type	New Model	Old Model
1-2 m ³ /h	51201A/51201B/51201C/51102/51202C	53502/52502H/53502B/64502/55502	61202/61202C	63502/62502/63502B/64502/65502	63602/62602/63602B/64602/65602	73502/72502/73502B/74502/74502Y	73602/72602/73602B/74602	41104	F70A	Suited with F63/F68
	F52/F56B/F56C/F56E/F56EC	F71B1/F71D1/F71G1/F71P/F71Q	F64B/F64BC	F65B1/F65D1/F65G1/F65P1/F117Q1	F65B3/F65D3/F65G3/65P3/F117Q3	F69A1/F69D1/F69G1/F69P1/F69PY	F69A3/F69D3/F69G3/F69P3	41102	F70B	Suited with F65/F69
3-4 m ³ /h	51104/51204C/51240	53504S/53504/52504H/53504B/54504/55504/56503/52504E	61104/61204C	63504S/63504/62504/63504B/64504/65504	63604S/63604/63604B/64604/65604	73504S/73504/72504/73504B/74504/74504Y	73604S/73604/72604/73604B/74604	41204	F70C	Suited with F63/F68/F82
	F56A/F56K/F56AC	F67B/F67C1/F67D1/F67G1/F67P/F67Q/F67N/F67K	F64A/F64AC	F63B1/F63C1/F63D1/F63G1/F63P1/F116Q1	F63B3/F63C3/F63G3/F63P3/F116Q3	F68A1/F68C1/F68D1/F68G1/F68P1/F68PY	F68A3/F68C3/F68D3/F68G3/F68P3	41202	F70D	Suited with F79
5-6 m ³ /h	51106	53506S/53504-A	61206	63505E/63505	63605E/63605	72505/73505	72605/73605	41206	F70F	Suited with F97/92
	F56F	F67B-A/F67C1-A	N64F	F116A1/F130A1	F116A3/F130A3	F92A1-LCD/F92A1-LED	F92A-LCD/F92A-LED	41304	F70G	Suited with F63/F68/F79/F82/F105
8-10 m ³ /h	51208/51210	53508/53510/53510B/55510	61210	63508/63510/63510B/65510	63610/63610B			41302	F70H	Suited with F67N/F122
	F66L/N56D	F134A/N75A1/N75B1/N75Q	N64D	F133A/N74A1/N74B1/N74Q	N74A3/N74B3			41103	F70I	Suited with F79
12-18 m ³ /h	51215	53518/53515/53615	61215	63518/63515	63618/63615	73515	73615			
	F77BS	N77B1/F99B1/F99B3	F77AS	N77A1/F99A1	N77A3/F99A3	F99D1	F99D3			
20 m ³ /h		53520/53620		63520/63520T	63620/63620T	73520	73620			
		F95B1/F95B3		F95A1/F111A1	F95A3/F111A3	F95D1	F95D3			
30-40 m ³ /h	51240B	53540B/53640B	61240B	63540B	63640B					
	F112BS	F112B1/F112B3	F112AS	F112A1	F112A3					
50 m ³ /h		53550/53650		63550	63650					
		F96B1/F96B3		F96A1	F96A3					

Others			
Product	New Model	Old Model	Water Treatment Capacity
Downflow/Upflow Softener	83602	F79	2 m ³ /h
	82602	F105	2 m ³ /h
	82603E	F97A3	3 m ³ /h
	83604	F82A3	4 m ³ /h
	93604	F83A3	4 m ³ /h
Control Valve for Floating Bed	93606	F98C	6 m ³ /h
	93610	F88C	10 m ³ /h
	92115	F77CS	15 m ³ /h
	93620	F95C3	20 m ³ /h
	93640	F112C3	40 m ³ /h
One Valve on Duplex Tanks	17603	F73	3.5 m ³ /h
	17606	F98A	6 m ³ /h
	17606T	F137	6 m ³ /h
	17610T	F135	10 m ³ /h
	17610	F88A	10 m ³ /h
Electronic Three-way Valve	42020	F80	20 m ³ /h
On-line Sampling Monitory Device	44310	F84	
Disc Filter	45006	F90A	6 m ³ /h
	45012	F90B	12 m ³ /h
	45020	F90C	20 m ³ /h
	45040	F90D	40 m ³ /h

Appendix-2

Type	New Model	Old Model	Inlet/Outlet	Drain	Base	Riser Pipe	Brine Line Connector	Water Capacity (m ³ /h)	Tank Size	Regeneration Mode	Water Pressure	Turbidity
Manual Filter	51102/51202/51202C	F56E1/F56E2/F56E3	1/2" F or 3/4" F	1/2" F or 3/4" F	2.5" -SNPSM	1.05" OD		2	6" -10"		0.15-0.6 MPa	<20FTU
	51104/51204C/51104K	F56A/F56AC/F56K	1" F	1" F	2.5" -SNPSM	1.05" OD		4	6" -12"			
	51105/51205	F56F1/F56F2	1" F	1" F	2.5" -SNPSM	1" D-GB		6	6" -14"			
	51208	F56L	1.5" M	1.5" M	4" -8UN	1.25" D-GB 1.88" OD		8	10" -24"			
	51110/51210	N56C1/N56D2	2" F	2" F	4" -8UN	1.5" D-GB 1.9" OD		10	10" -24"			
	51215	F77B5	2" M	2" M	4" -8UN	1.5" D-GB 1.9" OD		15	30" - 40"			
	51240B	F112B5	DN65	DN65	Side-Mounted, DN80 Top and bottom strainer connector			40	36" -48"		0.2-0.6 MPa	
Automatic Filter	53502/53602/53502B/53502P/52502H/55502	F71B1/F71B3/F71G1/F71H/F71D/F71Q	3/4" M	3/4" M	2.5" -SNPSM	1.05" OD		2	6" -10"		0.2-0.6 MPa	
	53504/53504S/53504B/53504C/53504P/52504H/55504/56603M/52504E	F87C/F87B/F87G/F87H/F87D/F87Q/F87M/F87K	1" F F87M: 3/4" M		2.5" -SNPSM	1.05" OD		4	6" -24"		0.15-0.6 MPa	
	53505S	F87B1-A	1" F	1" F	2.5" -SNPSM	1" D-GB		6	6" -24"			
	53508/53608	F134A1/F134A3	1.5" M	1.5" M	4" -8UN	1.25" D-GB 1.88" OD		8	16" -24"			
	53510/53510B	N75AN75B	2" M	2" M	4" -8UN	1.5" D-GB 1.9" OD		10	6" -24"			
	53515	F99B	2" M	2" M	4" -8UN	1.5" D-GB 1.9" OD		15	20" -30"		0.2-0.6 MPa	<20FTU
	53518	N77B1	2" M	2" M	4" -8UN	1.5" D-GB 1.9" OD		18	24" -30"			
	535207/53620T	F111B1/F111B3	2" M	2" M	4" -8UN	2" D-GB		20	36" -48"			
	53520/53620	F98B1/F98B3	2" M	2" M	Side-Mounted, 2" M Top and bottom strainer connector			20	30" -36"			
	53540B/53540B	F112B1/F112B3	DN65	DN65	Side-Mounted, DN80 Top and bottom strainer connector			40	36" -48"			
	53550/53650	F98B1/F98B3	DN80	DN80	Side-Mounted, DN100 Top and bottom strainer connector			50	36" -48"			
	Manual Soften	61202/61202C/71202C	F84B/F84C/F84C	3/4" F	1/2" M	2.5" -SNPSM	1.05" OD	3/8" M	2	6" -12"		0.15-0.6 MPa
61104/61204/61204C		F84A1/F84A3/F84A4C	1" F	1/2" M	2.5" -SNPSM	1.05" OD	3/8" M	4	6" -18"			
61206		N84F	1.5" M	3/4" M	4" -8UN	1.25" D-GB	1/2" M	6	10" -28"			
61210		N84D	2" M	1" M	4" -8UN	1.5" D-GB	1/2" M	10	10" -30"			
61215		F77AS	2" M	2" M	4" -8UN	1.5" D-GB	3/4" M	15	30" -40"		0.2-0.6 MPa	
61240B		F112AS	DN65	DN65	Side-Mounted, DN80 Top and bottom strainer connector		3/4" M	40	48" -60"			
Automatic Softener		63502/63502B/63502P/62502/65503	F85B/F85G/F85P/F85D/F117Q	3/4" F	1/2" M	2.5" -SNPSM	1.05" OD	3/8" M	2	6" -12"	Downflow	
	73502/73502B/73502P/72502/75502	F89A/F89G/F89P/F89D/F89Q	3/4" F	1/2" M	2.5" -SNPSM	1.05" OD	3/8" M	2	6" -12"	Upflow		<
	63504S/63504/63504B/63504C/63504P/62504H/65504/65505/63505E	F83B/F83C/F83G/F83H/F83P/F83D/F116Q/F118E	1" M	1/2" M	2.5" -SNPSM	1.05" OD	3/8" M	4	6" -18"	Downflow		<5FTU
	73504S/73504/73504B/73504C/73504P/72504/75504	F89A/F89C/F89G/F89P/F89D/F89Q	1" M	1/2" M	2.5" -SNPSM	1.05" OD	3/8" M	4	6" -18"	Upflow		<5FTU
	63505/63605	F118A1/F118A3	1" M	3/4" M	2.5" -SNPSM	1.05" OD	3/8" M	4	6" -18"	Downflow		<5FTU
	73505/73605	F82A1/F82A3	1" M	3/4" M	2.5" -SNPSM	1" D-GB	3/8" M	5	10" -24"	Upflow		<5FTU
	63508/63608	F133A1/F133A3	1.5" M	3/4" M	4" -8UN	1.25" D-GB 1.88" OD	1/2" M	8	24" -30"	Downflow		<5FTU
	63510/63510B	N74AN74B	2" M	1" M	4" -8UN	1.5" D-GB 1.9" OD	1/2" M	10	20" -30"	Downflow		<5FTU
	63515/73615	F99A/F99D	2" M	1.5" M	4" -8UN	1.5" D-GB 1.9" OD	3/4" M	15	30" -40"	F99A Downflow F99D Upflow		Downflow<5FTU Upflow<2FTU
	63518/63618	N77A1/N77A3	2" M	1.5" M	4" -8UN	1.5" D-GB 1.9" OD	3/4" M	18	30" -40"	Downflow		0.2-0.6 MPa <5FTU
	63620/73520	F95A/F95D	2" M	1.5" M	Side-Mounted	/	3/4" M	20	30" -48"	F95A Downflow F95D Upflow		Downflow<5FTU Upflow<2FTU
	63620T	F111A	2" M	1.5" M	4" -8UN	2" D-GB	3/4" M	20	36" -48"	Downflow		<5FTU
	63640B	F112A	DN65	DN65	Side-Mounted, DN80 Top and bottom strainer connector		3/4" M	40	48" -60"	Downflow		<5FTU
	63650	F98A	DN80	DN80	Side-Mounted, DN100 Top and bottom strainer connector		3/4" M	50	60" -72"	Downflow		<5FTU
	82602/82602B	F79A-LCD/F79B-LCD	3/4" M	1/2" M	2.5" -SNPSM	1.05" OD	3/8" M	2	6" -18"	Down/Upflow		<5FTU or <2FTU
83604/82604B	F82A-LCD/F82B-LCD	1" M	1/2" M	2.5" -SNPSM	1.05" OD	3/8" M	4	6" -18"	Down/Upflow		0.15-0.6 MPa <5FTU or <2FTU	
One Valve On Duplex Tanks	17603	F73	1" M	1/2" M	2.5" -SNPSM	1.05" OD	3/8" M	3.5	12" -14"	Down/Upflow		<5FTU or <2FTU
	17606	F88A	1" M	3/4" M	Side-Mounted, 1" M Top and bottom strainer connector		1/2" M	6	20" -24"	Upflow		0.15-0.6 MPa <5FTU
	17610	F88A	1.5" M	1" M	Side-Mounted, 1.5" M Top and bottom strainer connector		1/2" M	10	20" -30"	Upflow		<5FTU
	17610T	F135A	1.5" M	3/4" M	4" -8UN	1.5" D-GB 1.9" OD	1/2" M	10	20" -30"	Downflow		0.2-0.6 MPa <5FTU
Control Valve for Floating Bed	17605T	F137	1" M	3/4" M	4" -8UN	1.5" D-GB (32 mm OD)	1/2" M	6	16" -24"	Top mounted Downflow		<5FTU
	93504	F83A	1" M	1/2" M	2.5" -SNPSM	1.05" OD	3/8" M	4	10" -14"		0.15-0.6 MPa	<5FTU
	93506	F86C	1" M	3/4" M	Side-Mounted, 1" M Top and bottom strainer connector		1/2" M	6	16" -24"			<5FTU
	93610	F88C	1.5" M	1" M	Side-Mounted, 1.5" M Top and bottom strainer connector		1/2" M	10	20" -24"			<5FTU
	91215	F77CS	2" M	2" M	4" -8UN	1.5" D-GB	3/4" M	15	20" -30"		0.2-0.6 MPa	<5FTU
	93520/93620	F96C1/F96C3	2" M	1.5" M	3/4" M	2" M	3/4" M	20	30" -36"			<5FTU
	91240B/93540B	F112CS/F112C	DN65	DN65	Side-Mounted, DN80 Top and bottom strainer connector		3/4" M	40	36" -48"			<5FTU
	Control valve for achieving one valve on duplex tanks and working in series											
12604	F142A	1" M	NPT3/4	2.5" -SNPSM	1" D-GB	3/8" M	4	6" -18"	Downflow (Brine Draw)		0.15-0.6 MPa	<5FTU
12504	F142B	1" M	NPT3/4	2.5" -SNPSM	1" D-GB	3/8" M	4	6" -18"	Downflow (Air Draw)			<5FTU



www.redawatergroup.com - info@redawatergroup.com

