

EXISTING 8 X 8 WALKWAY COLUMN

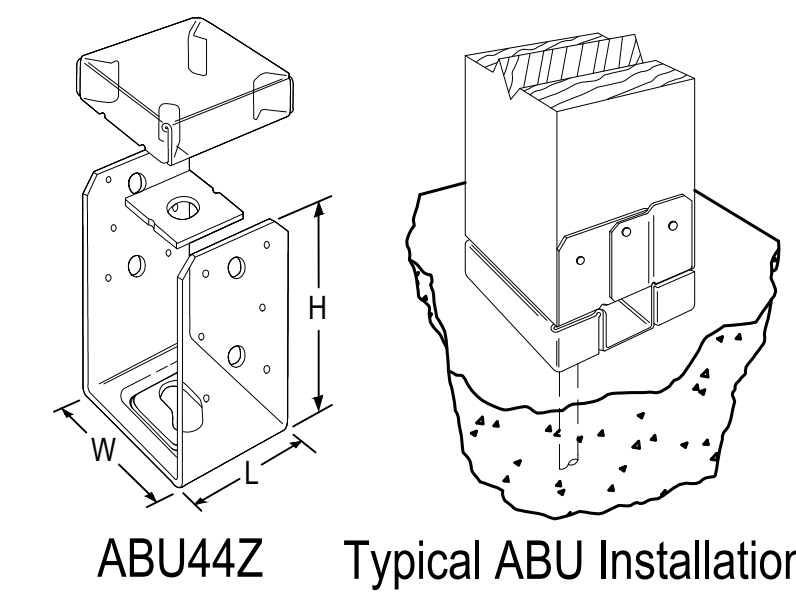
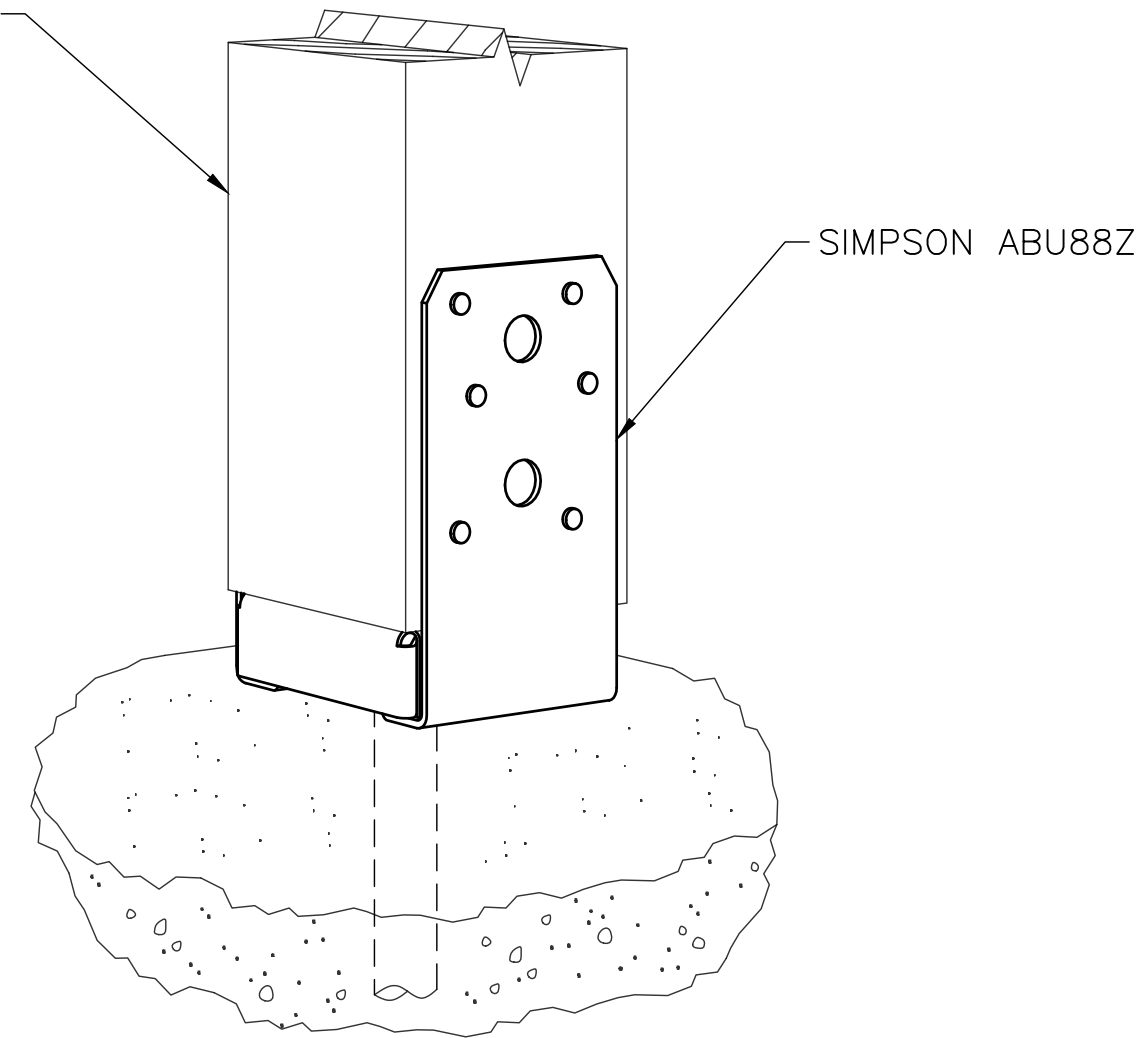

Installation:

- ABU - for pre-pour installed anchors. For Simpson Strong-Tie epoxy or mechanical anchors, select and install in accordance with www.strongtie.com.
- Products require washers between the nut and the base. Washers are supplied with the ABU.

Model No.	Post Size	Dimensions (in.)				Anchor Dia.	Post Fasteners			
		W	L	H	HB		Nails	SD Screws	Machine Bolts	
								Qty.	Dia.	
ABU66Z	6x6	5 1/2	5	6 1/16	1 3/4	5/8	12-16d	-	2	1/2
ABU88Z	8x8	7 1/2	7	7	-	2 - 5/8	18-16d	-	-	-

REPAIR PROCEDURE:

1. TEMPORARILY SHORE THE WALKWAY ABOVE.
2. USING A LASER LINE, CUT ALL COLUMNS A MINIMUM OF 6" ABOVE TOP OF CONCRETE, REMOVING ALL DETERIORATED WOOD. CUTS MUST BE SQUARE TO THE COLUMN.
3. CUT THE EXISTING WALKWAY CONCRETE AS REQUIRED TO PROVIDE CLEARANCE FOR THE SONOTUBE.
4. EXCAVATE TO THE TOP OF THE EXISTING FOOTER.
5. INSTALL 4 NO. 4 X 20" LG REBAR W/ 6" EMBEDMENT USING EPOXY ADHESIVE AND (2) NO. 4 REINFORCEMENT HOOPS AS SHOWN, MAINTAINING 3" MINIMUM COVER.
6. APPLY A RELEASE AGENT TO THE 14" SONOTUBE FORM AND INSTALL RESTING ON TOP OF THE EXISTING FOOTER.
7. INSTALL (2) TWO 5/8" X 8" LG THREADED RODS AT THE CENTER OF THE ABU88Z POST BASE.
8. INSTALL THE TOP PLATE OF THE BASE AND FASTEN TO THE COLUMN USING 16D GALVANIZED NAILS.
9. POUR 3000 PSI CONCRETE TO THE BOTTOM OF THE COLUMN BASE SUPPORT.
10. AFTER THE CONCRETE CURES, REMOVE THE SONOTUBE FORM PER MANUFACTURERS RECOMMENDATIONS.
11. RE-ROUTE ADJACENT DOWN SPOUTS AS REQUIRED.

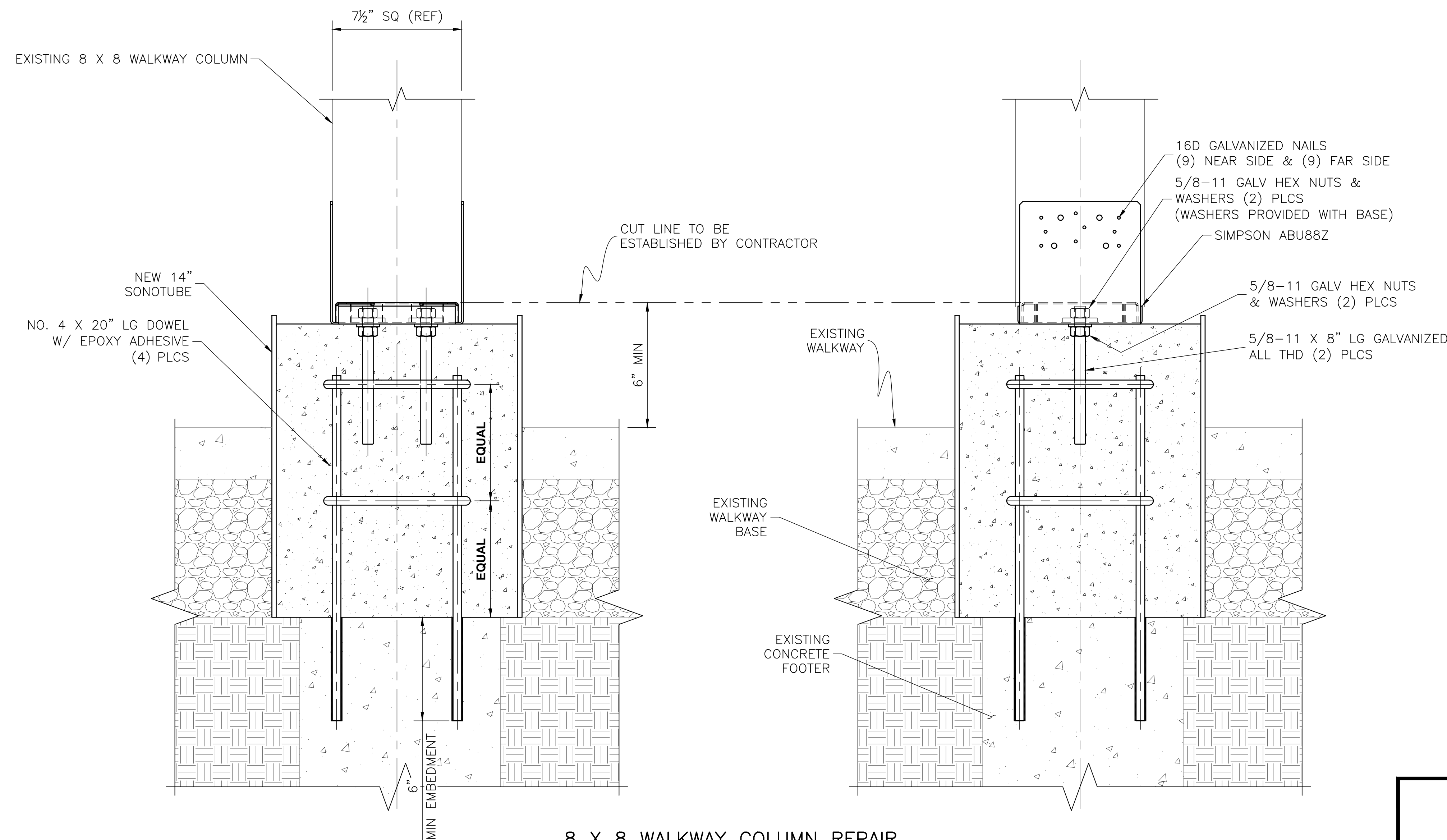

**8 X 8 WALKWAY COLUMN REPAIR
W/ BURIED FOOTER**
SCALE: 3" = 1'-0"

PROJECT No. G6970		 GLOBEX CORPORATION ENGINEERS AND CONSULTANTS CANFIELD, OHIO
CUSTOMER No.		
DRN: CPE	DATE: 06/08/23	
CHKD:	DATE:	
APPD:		DATE:
MARINERS POINT CONDO ASSOCIATION 8 X 8 WALKWAY COLUMN BASE REPAIR PROCEDURES		
SCALE: AS NOTED	DWG. No. G7053-002	REV. -
REV.	DESCRIPTION	DATE BY CHKD

The content of this document remains the full property of the Globex Corporation; the document may neither be reproduced nor communicated to third parties in any way, nor used for own purpose, particularly for the execution of what is therein represented, without the written authorization of the Globex Corporation.