



---

A M E R I C A

---

**Illustrated  
Parts:  
Model 722**

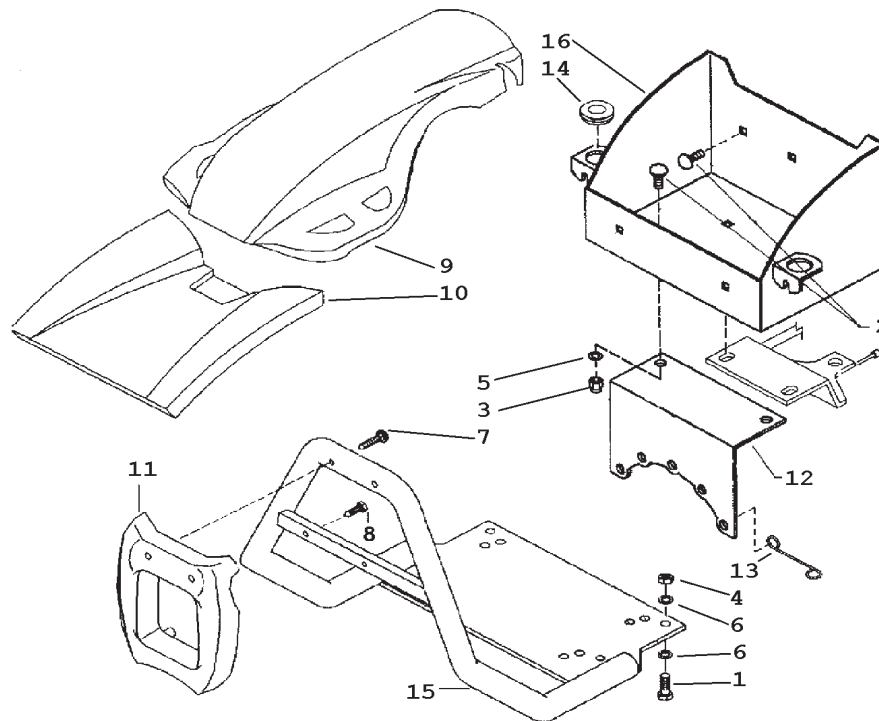

700.01.0-01.2

ID	PART NO	DESCRIPTION	ID	PART NO	DESCRIPTION
1	311.12154	CAPSCREW, M8X40 UNI 57398G	11	552.57622	FRONT BUMPER GUARD
2	311.21558	BOLT, M6 X 16	12	561.57393	BATTERY/TOOL BOX SUPPORT
3	312.41060	NUT, LOCK M6	13	580.48035	SUPPORT, GAS CABLE SHEATH
4	312.41080	NUT, LOCK M8	14	580.56991	CAP
5	314.11064	WASHER, FLAT, M6 4X12	15A	590.56113	BUMPER, HONDA GX8
6	314.11084	WASHER, FLAT, M8 4X17	15B	590.56123	BUMPER, BRIGGS
7	315.10099	SCREW, SELF TAPPING, M6.3X38	16A	590.57399	SUPPORT, LOWER GUARD
8	315.10100	SCREW, SELF TAPPING, M6.3X19	16B	590.57395	BATTERY BOX, ELECTRIC START
9	552.57620	COVER, HANDLEBAR			
10	552.57621	GUARD, LOWER			

Revised 01/10/2012

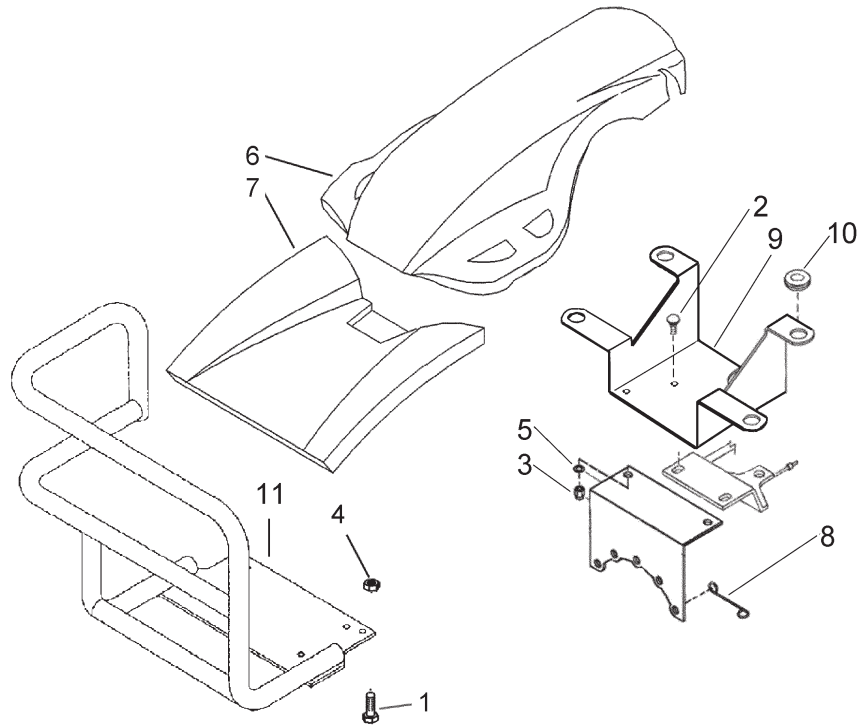

700.01.3-01.4

ID	PART NO	DESCRIPTION	ID	PART NO	DESCRIPTION
1	311.12154	CAP SCREW, M8X40 UNI 5739-8G			
2	311.21558	BOLT, M6 X 16			
3	312.41060	NUT, LOCKNUT, M6			
4	312.41084	NUT, FLANGED, LOCK M8			
5	314.11064	WASHER, FLAT, M6			
6	552.57620	COVER, HANDLEBAR			
7	552.57621	GUARD, LOWER			
8	580.48035	SUPPORT, GAS CABLE SHEATH			
9	561.57399	SHIELD SUPPORT, RECOIL ONLY!!!			
10	580.56991	CAP			
11	590.56113	BUMPER, WRAP AROUND			

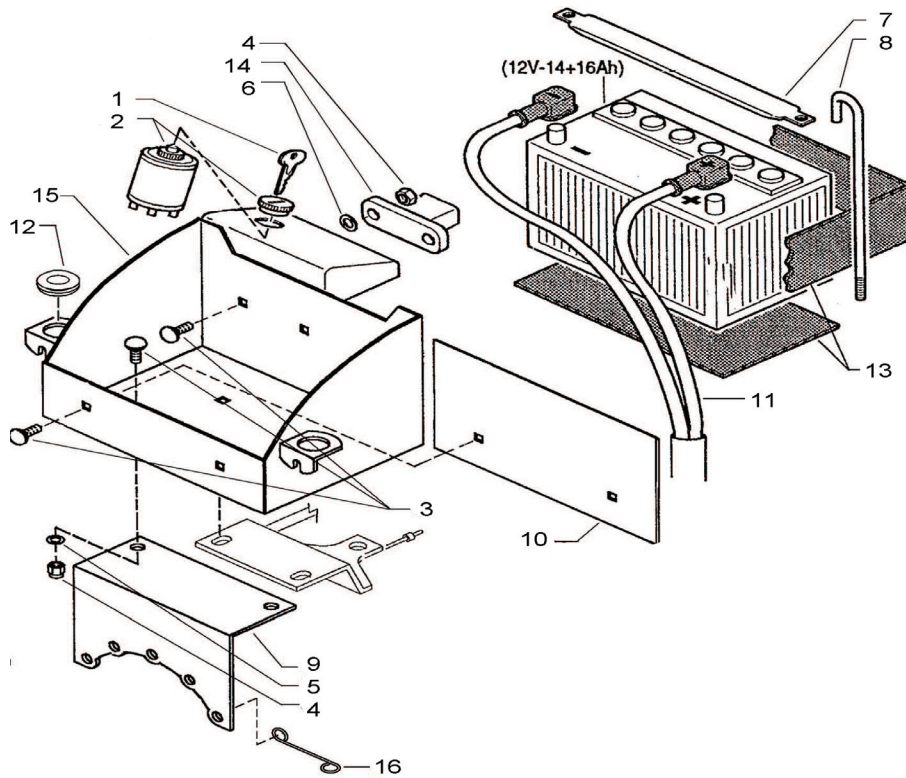

700.01.0-01.2

ID	PART NO	DESCRIPTION	ID	PART NO	DESCRIPTION
1	300.00276	KEY	11	580.57396	BATTERY CABLES
2	300.00277	SWITCH	12	580.56991	SUPPORT, BODY GAURD
3	311.21558	SCREW	13	580.57397	PAD SET
4	312.41060	LOCKNUT, M6	14	581.57389	SOLENOID
5	314.11064	WASHER FLAT M6.4X12	15	590.57395	BATTERY BOX
6	314.11090	WASHER, FLAT M9X24	16	580.48035	SUPPORT, THROTTLE CABLE
7	561.19937	BRACKET, BATTERY			
8	561.57387	ROD			
9	561.57393	BATTERY SUPPORT			
10	561.57398	SHIELD 6.5 & 8HP INTEK			

Revised 01/10/2012

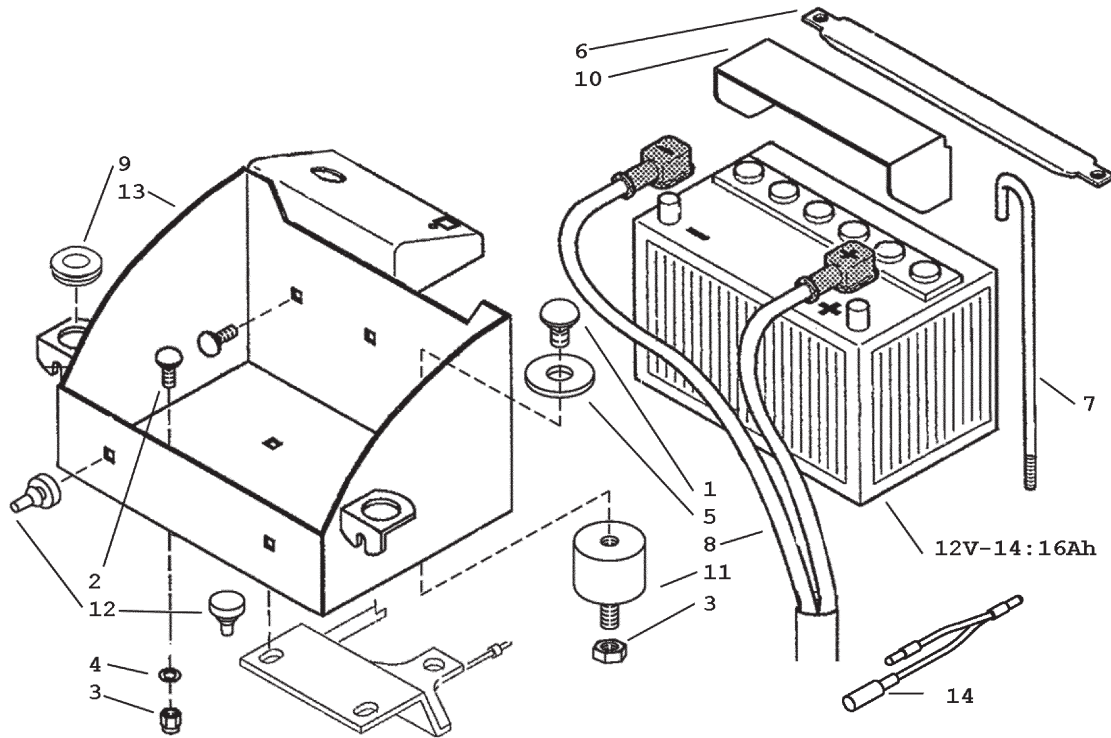

700.01.3-01.4

ID	PART NO	DESCRIPTION	ID	PART NO	DESCRIPTION
1	311.00201	BOLT W/SQUARE NUT, M6X12	11	581.35225	SHOCK MOUNT
2	311.21558	BOLT, M6X16	12	581.57405	RUBBER CUSHIONS
3	312.41060	LOCKNUT, STANDARD, M6	13	590.57390	BATTERY BOX
4	314.11064	WASHER	14	580.57385	WIRING HARNESS (HONDA)
5	314.11090	WASHER, FLAT, M9X24			
6	561.19937	BATTERY BRACKET			
7	561.57387	ROD, BATTERY			
8	580.47460	CABLE, ELECTRIC START			
9	580.56991	SUPPORT, CAP			
10	580.57610	BATTERY COVER			

Revised 01/10/2012

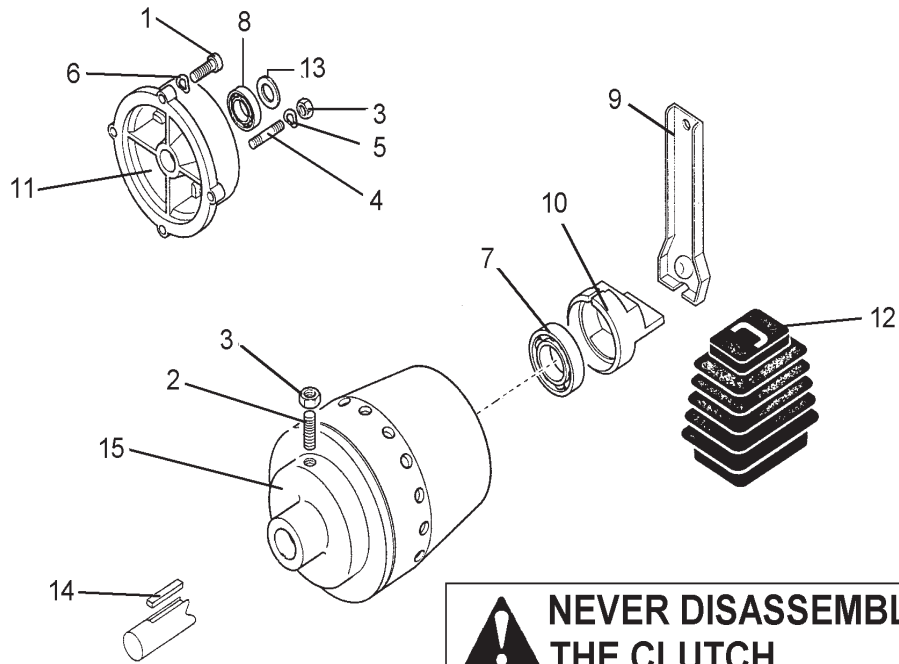

**⚠ NEVER DISASSEMBLE THE CLUTCH**

700- 02.0

ID	PART NO	DESCRIPTION	ID	PART NO	DESCRIPTION
1	311.00015	SCREW, 3/8X1"	11	531.56166	FLANGE
2	311.00787	SCREW, M8X35	12	551.57609	BOOT
3	312.11080	NUT, M8	13	563.47484	WASHER
4	313.12088	STUD, M8X40X14X14	14	563.49782	KEY
5	314.23084	WASHER, WAVEY	15	592.47907	CLUTCH (INCLUDES 7 & 10)
6	314.23105	WASHER, WAVEY			
7	371.12173	BEARING, M17X40X12			
8	371.12233	BEARING, M20X47X14			
9	509.56262	LEVER, RECOIL START			
10	524.47896	CONE PUSHER			

Revised 01/10/2012

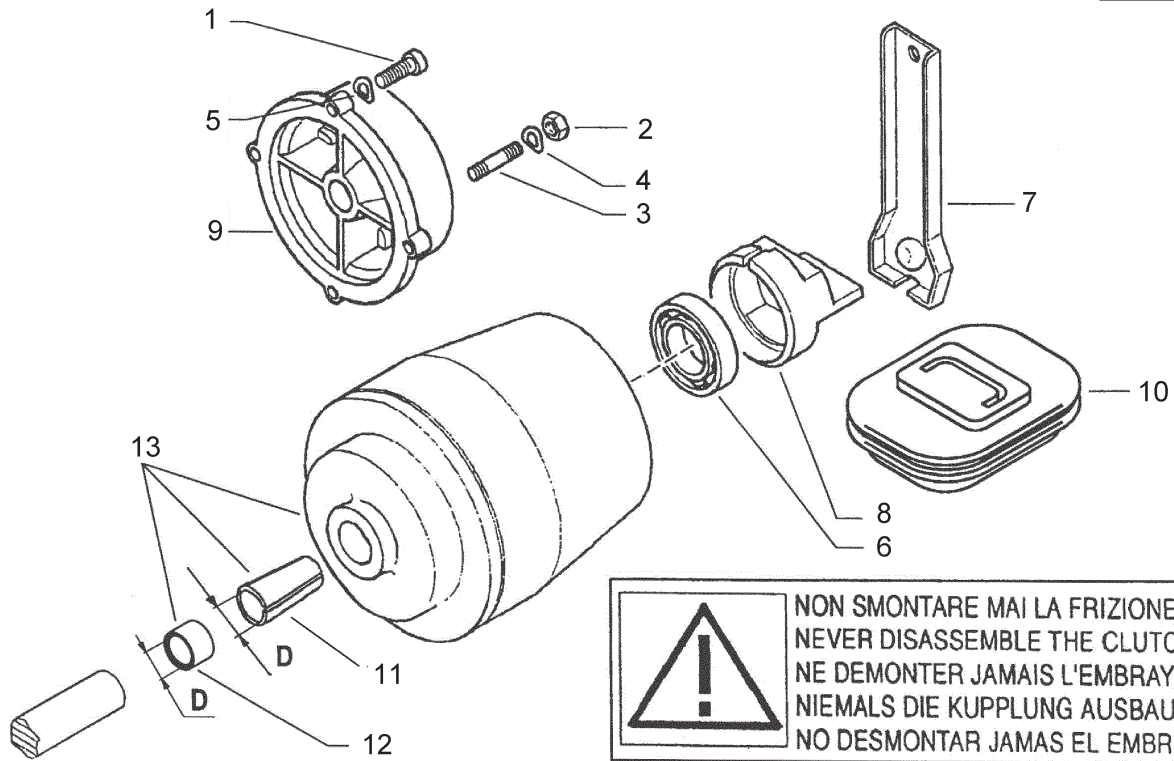

700- 02.1-02.2

ID	PART NO	DESCRIPTION	ID	PART NO	DESCRIPTION
1	311.00015	SCREW, 3/8X1"	11	561.56281	SPACER (D=25.4)
2	312.11080	NUT, M8	12	561.56285	SPACER (D=25.4)
3	313.12088	STUD, M8X40X14X14	13	592.56279	CLUTCH (INCLUDES 6 & 8)
4	314.23084	WASHER, WAVE			
5	314.23105	WASHER. WAVE			
6	371.12173	BEARING, M17X40X12			
7	509.56262	LEVER, RECOIL START			
8	524.47896	PUSHER CONE			
9	531.56150	FLANGE			
10	551.57609	BOOT			

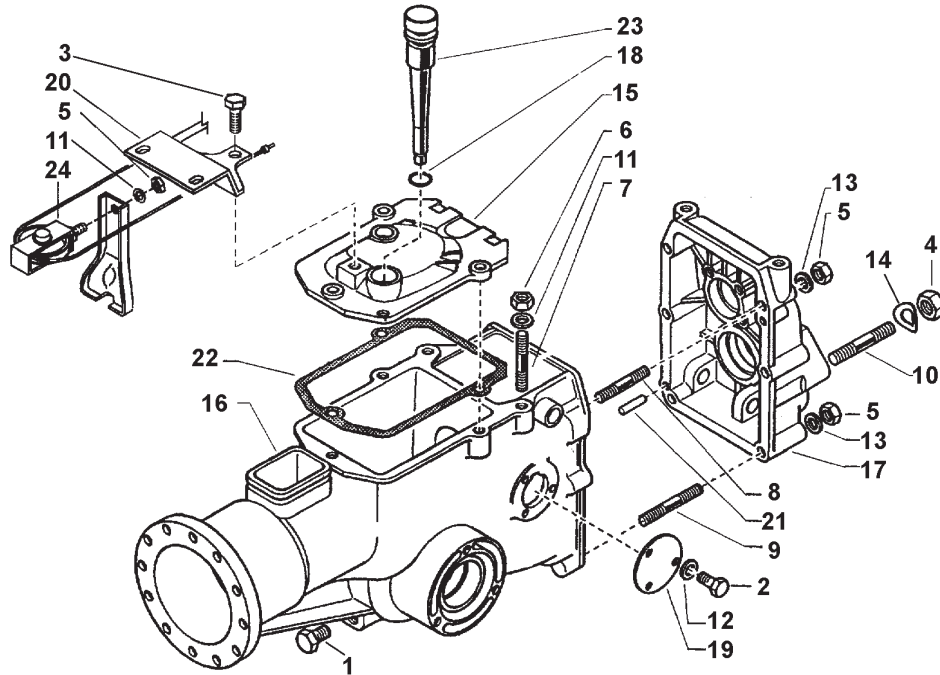

700- 03.0-03.1

ID	PART NO	DESCRIPTION	ID	PART NO	DESCRIPTION
1	300.40001	PLUG	16	531.56325	GEAR BOX CASE
2	311.11090	SCREW, COUNTER SUNK, M6X16	17	531.56332	REAR COVER
3	311.12210	CAP SCREW	18	551.02678	"O" RING
4	312.21121	NUT, M12X1.25	19	561.47520	SIDE COVER
5	312.41080	NUT, SELF LOCKING, M8	20	561.57394	PLATE
6	312.41080	NUT	21	580.43053	PARALLEL PIN
7	313.12082	STUD, M8X38X14X20	22	580.43117	GASKET, COVER
8	313.12086	STUD, M8X56X20X12	23	590.15425	CAP WITH DIP STICK
9	313.12094	STUD, M8X68	24	590.56258	PULLEY ASSEMBLY
10	313.12125	STUD, M12X1.25X12X64			
11	314.21083	SUPER WASHER, M8			
12	314.22064	WASHER, LOCK, M6.4			
13	314.23084	WASHER, LOCK, M8.4			
14	314.21132	WASHER, DOME, M13 ***			
15	531.43128	GEARBOX COVER			

\*\*\* Note: Dome should be oriented towards the nut.



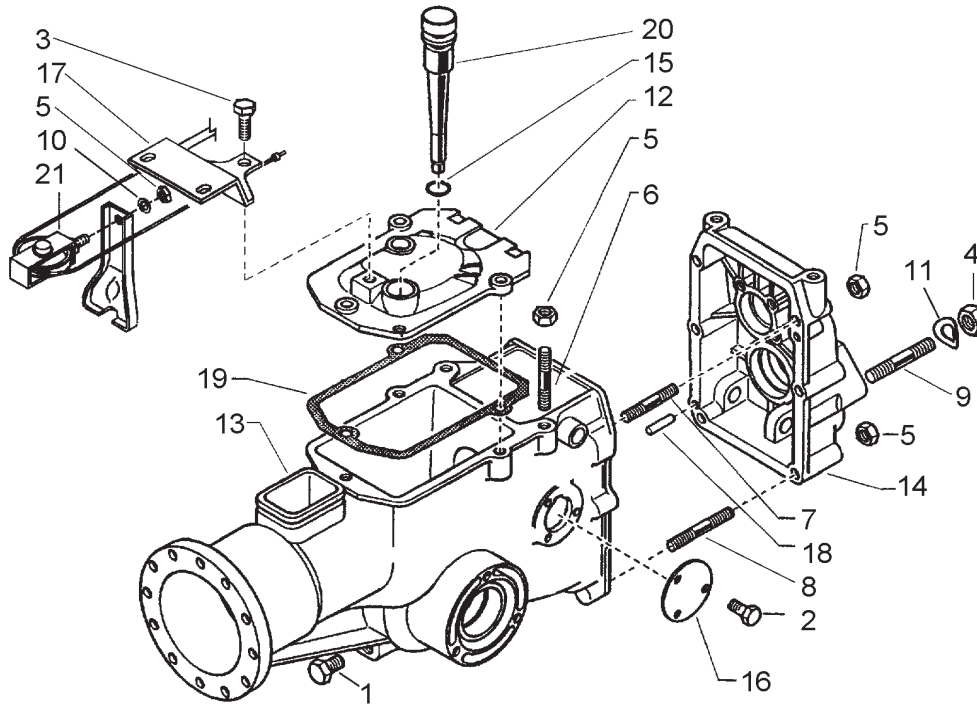

700- 03.2

ID	PART NO	DESCRIPTION	ID	PART NO	DESCRIPTION
1	300.40001	PLUG	16	561.47520	SIDE COVER
2	311.12083	SCREW	17	561.57394	PLATE
3	311.12210	CAP SCREW	18	580.43053	PARALLEL PIN
4	312.21121	NUT, M12X1.25	19	580.43117	GASKET, COVER
5	312.41084	NUT, SELF LOCKING, M8	20	590.15425	CAP WITH DIP STICK
6	313.12082	STUD, M8X38X14X20	21	590.56258	PULLEY ASSEMBLY
7	313.12086	STUD, M8X56X20X12			
8	313.12094	STUD, M8X68			
9	313.12125	STUD, M12X1.25X12X64			
10	314.21083	SUPER WASHER, M8			
11	314.21132	WASHER, DOME, M13 ***			
12	531.43128	GEARBOX COVER			
13	531.56325	GEAR BOX CASE			
14	531.56332	REAR COVER			
15	551.02678	"O" RING			

\*\*\* Note: Dome should be oriented towards the nut.

Revised 11/09/2015

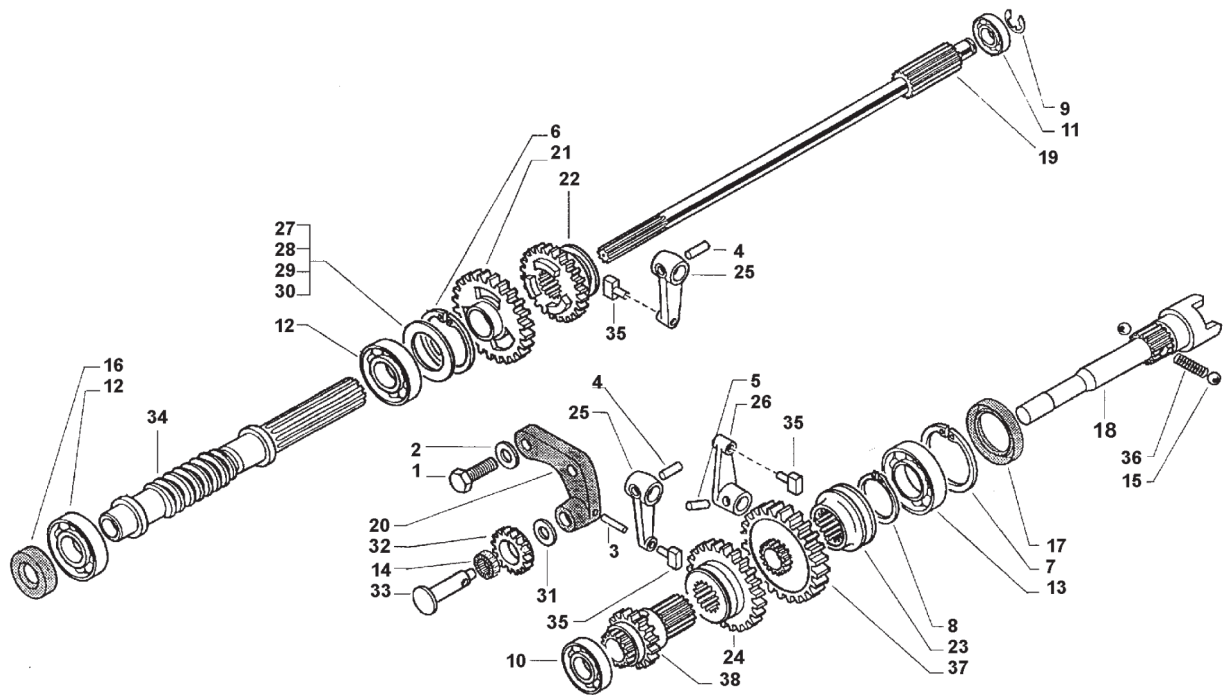

700- 05.0

ID	PART NO	DESCRIPTION	ID	PART NO	DESCRIPTION
1	311.12211	SCREW, M10X30	21	524.56354	FIRST GEAR
2	314.21101	SUPER WASHER, M10	22	524.56361	SLIDER GEAR
3	342.13024	LOCKING PIN, M4X25	23	524.56362	PTO SLIDER
4	342.13060	LOCKING PIN, M6X24	24	524.56370	SLIDER, REVERSER
5	342.13061	LOCKING PIN, M6X20 SPIRAL	25	524.56389	LEVER, SLIDER
6	351.11052	CIRCLIP, INTERNAL	26	524.56390	LEVER, PTO ENGAGEMENT
7	351.11055	CIRCLIP, INTERNAL	27	563.56328	SHIM, 1.5MM
8	351.21031	CIRCLIP, EXTERNAL	28	563.56329	SHIM, 1.6MM
9	352.11120	RETAINING RING	29	563.56330	SHIM, 1.7MM
10	371.11151	BEARING, M15X35X11	30	563.56331	SHIM, 1.8MM
11	371.11152	BEARING, M15X42X13	31	563.56348	WASHER
12	371.11255	BEARING, M25X52X15	32	564.56347	REVERSE GEAR
13	371.12229	BEARING, M30X55X13	33	564.56351	PIN, REVERSE GEAR
14	373.20120	BEARING, M12X15X10	34	564.56475	WORM GEAR
15	379.10832	BALL, 1/4"	35	580.43086	SHOE
16	382.11500	OIL SEAL, M15X40X10	36	580.56391	SPRING, PTO BALLS
17	382.13800	OIL SEAL, M38X55X7	37	590.56365	PTO GEAR
18	524.56335	PTO SHAFT	38	590.56384	GEAR
19	524.56339	MAIN SHAFT			
20	524.56349	REVERSER BRACKET			

# 722

## Transmission

### Serial Number Range 937702 -----

# 5.01

\* = New Part or Change

# = Note

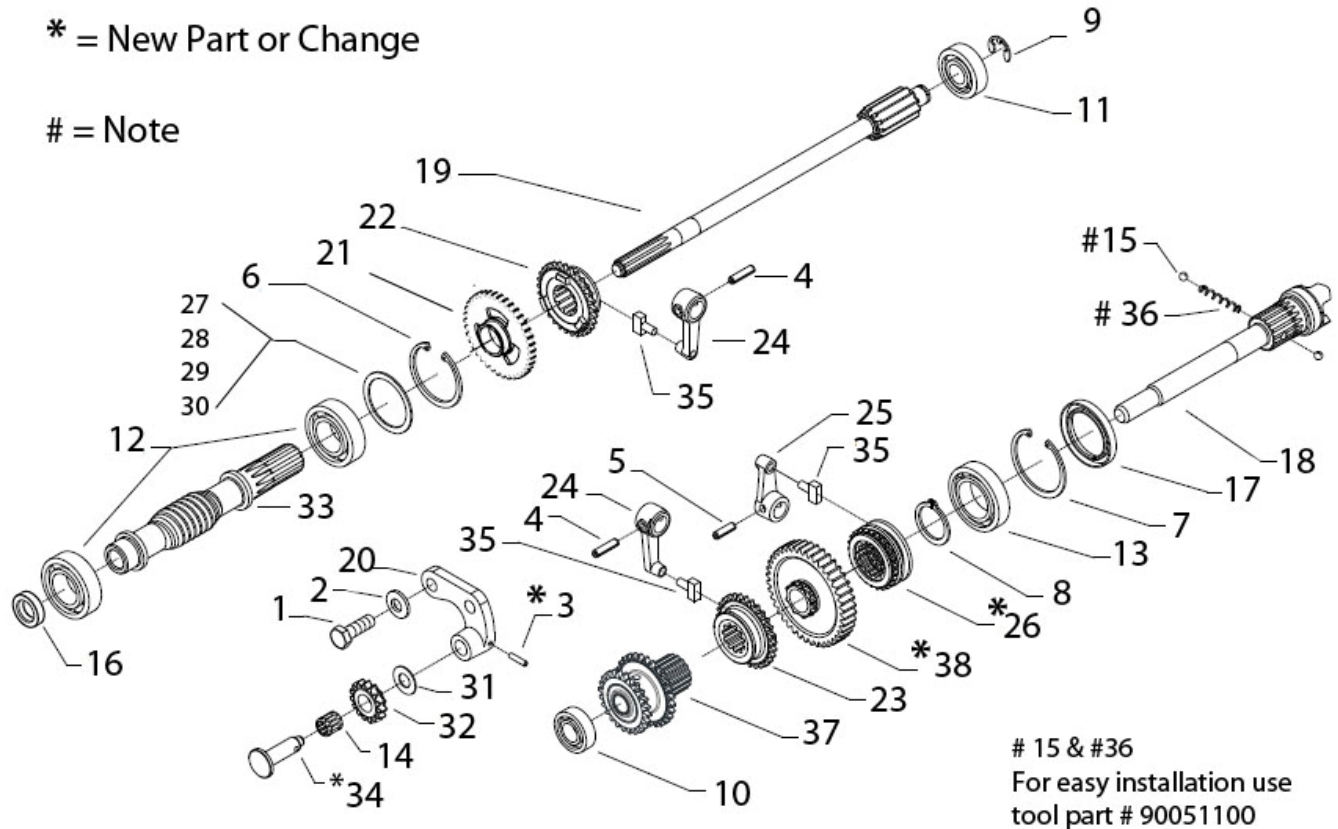

# 15 & #36  
For easy installation use  
tool part # 90051100

ID	PART NO	DESCRIPTION	ID	PART NO	DESCRIPTION
1	31112211	SCREW TE M10X30 UNI 5739	21	52456354	FIRST GEAR
2	31421101	WASHER M10	22	52456361	SLIDER GEAR
*3	34213024	ROLL PIN M4X24	23	52456370	PTO SLIDER
4	34213060	ROLL PIN M6X24	24	52456389	LEVER SLIDER
5	34213061	ROLL PIN M6X20 SPIRAL	25	52456390	LEVER PTO ENGAGEMENT
6	35111052	SEEGER RING I 52 DIN 472	*26	52456706	PTO SLIDER
7	35111055	SEEGER RING I 55 DIN 472	27	56356328	SHIM 1.5 MM
8	35121031	SEEGER RING E 30 UNI 7436	28	56356329	SHIM 1.6 MM
9	35211120	SEEGER RING E 12 UNI 7434	29	56356330	SHIM 1.7 MM
10	37111150	BEARING M15X35X11	30	56356331	SHIM 1.8 MM
11	37111152	BEARING M15X42X13	31	56356348	ADJUSTING RING
12	37111255	BEARING M25X52X15	32	56456347	REVERSER GEAR
13	37112229	BEARING M30X55X13	33	56456475	WORM GEAR
14	37320120	BEARINGGM 12X15X10	*34	56456736	PIN
#15	37910832	BALL 1/4	35	58043086	SHOE
16	38211500	OIL SEAL 15X28X7	#36	58056391	SPRING FOR PTO BALLS
17	38213800	OIL SEAL 38X55	37	59056384	DOUBLE GEAR
18	52456335	PTO SHAFT	*38	59056707	PTO GEAR
19	52456339	MAIN INPUT SHAFT		59968940	PTO KIT CONSISTS OF *26 & *38
20	52456349	REVERSER BRACKET			

Revised 01/10/2012

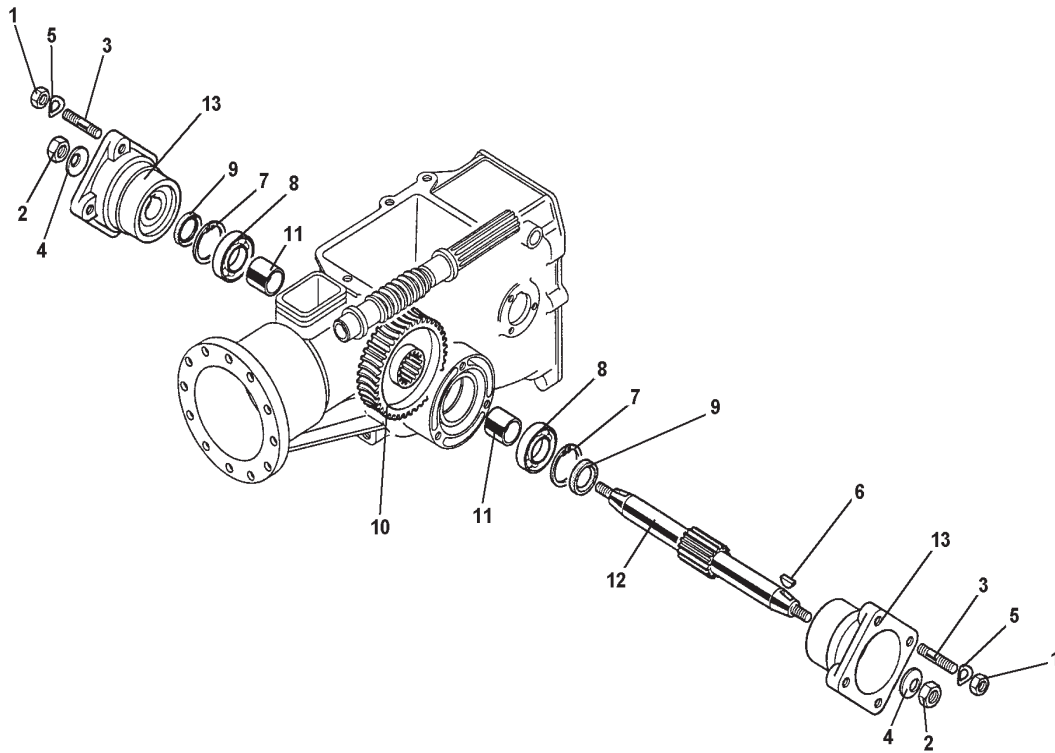

700 - 06.00

ID	PART NO	DESCRIPTION	ID	PART NO	DESCRIPTION
1	312.11100	NUT, M10	11	561.43059	SPACER
2	312.41120	NUT, SELF LOCKING, M12	12	563.43058	WHEEL SHAFT
3	313.12102	STUD, M10X40X22X14	13	590.43063	HUB, WHEEL WITH STUDS
4	314.21130	SUPER WASHER, M12			
5	314.23105	WASHER, LOCK, M10.5			
6	343.11060	KEY, M6X10			
7	351.11052	CIRCLIP, INTERNAL			
8	371.11250	BEARING, M25X52X15			
9	382.12501	OIL SEAL, M25X52X10			
10	541.43090	GEAR			

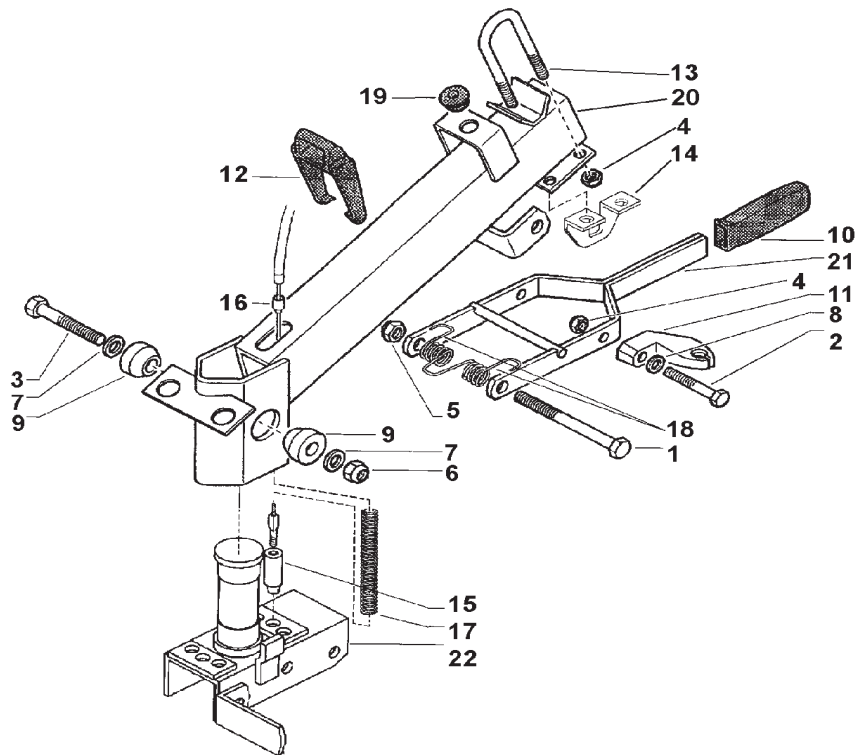

700- 09.0

ID	PART NO	DESCRIPTION	ID	PART NO	DESCRIPTION
1	311.11229	CAP SCREW, M10X110	17	580.56918	SPRING, STEERING COLUMN
2	311.12153	CAP SCREW, M8X35	18	580.56942	HANDLEBAR RELEASE SPRING
3	311.12293	CAP SCREW, M12X80	19	580.56991	SUPPORT CAP
4	312.41080	LOCK NUT, M8	20	590.56912	STEERING COLUMN
5	312.41100	LOCK NUT, M10	21	590.56935	LEVER, HANDLEBAR SELECTION
6	312.41126	LOCK NUT, M12 DEFORMED	22	590.56952	SUPPORT
7	314.21100	SPRING			
8	314.23084	WASHER LOCK, M8.4			
9	521.56917	WEDGE			
10	551.02714	KNOB			
11	552.43340	SUPPORT, CONTROL ROD			
12	552.49668	CABLE GUIDE			
13	561.56940	U BOLT			
14	561.56948	BRACKET			
15	563.56924	CAP			
16	580.42167	SHEATH END			

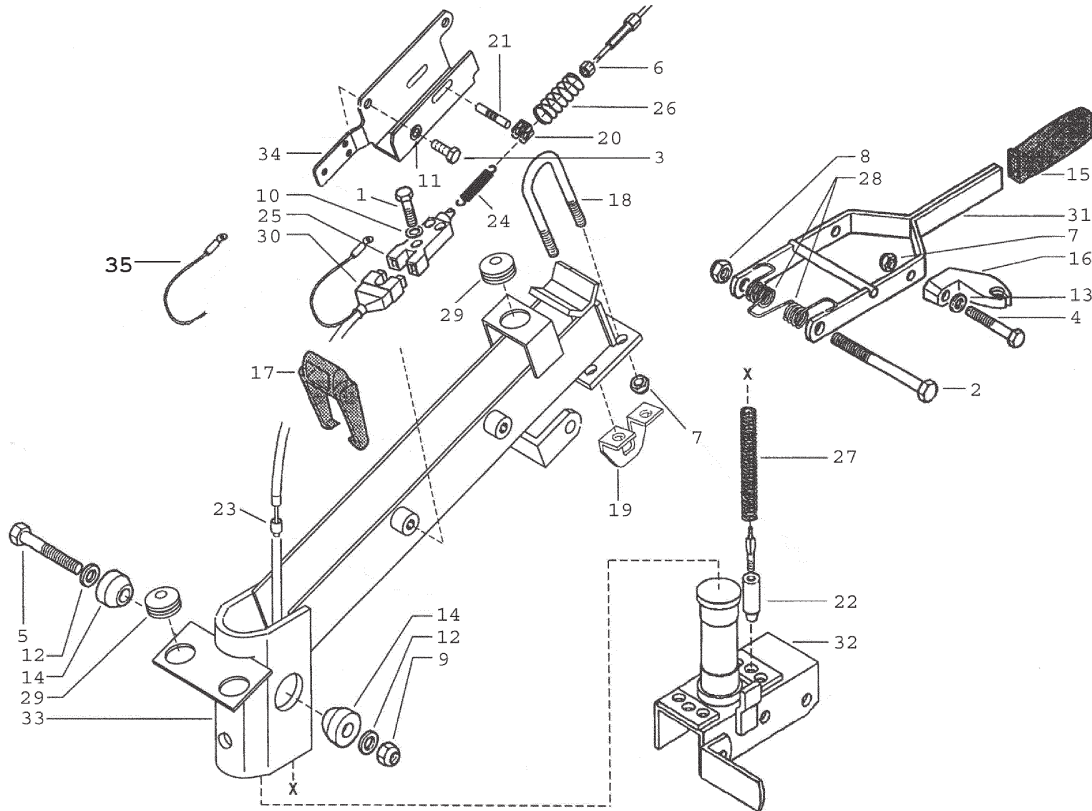

700-09.1-09.2

ID	PART NO	DESCRIPTION	ID	PART NO	DESCRIPTION
1	311.11086	CAP SCREW, M4.7X25	22	563.56924	CAP
2	311.11229	CAP SCREW, M10X110	23	580.42167	SHEATH END
3	311.12150	CAP SCREW, MX20	24	580.47712	SPRING, STOP
4	311.12153	CAP SCREW, M8X35	25	580.48009	STOP SWITCH
5	311.12293	CAP SCREW, M12X80	26	580.57413	CHECK SPRING, MOTOR STOP
6	312.11080	NUT, M8	27	580.56918	SPRING, STEERING COLUMN
7	312.41080	LOCK NUT, M8	28	580.56942	HANDLEBAR RELEASE SPRING
8	312.41100	LOCK NUT, M10	29	580.56991	SUPPORT CAP
9	312.41126	LOCK NUT, M12 DEFORMED	30	580.57417	MOTOR STOP WIRING
10	314.11043	WASHER, FLAT, M4	31	590.56935	LEVER, HANDLEBAR SELECTION
11	314.21083	WASHER, SUPER M8	32	590.56952	SUPPORT
12	314.21100	SPRING WASHER	33	590.56995	STEERING COLUMN
13	314.23084	WASHER LOCK B 8.4	34	592.57409	SUPPORT, ENGINE STOP
14	521.56917	WEDGE	35	580.57419	GROUND WIRE, FOR S/N 794196+
15	551.02714	KNOB			
16	552.43340	SUPPORT, CONTROL ROD			
17	552.49668	CABLE GUIDE			
18	561.56940	U BOLT			
19	561.56948	BRACKET			
20	561.57411	MOTOR STOP FORK			
21	561.57412	SPRING CHECK PIN			

Revised 01/10/2012

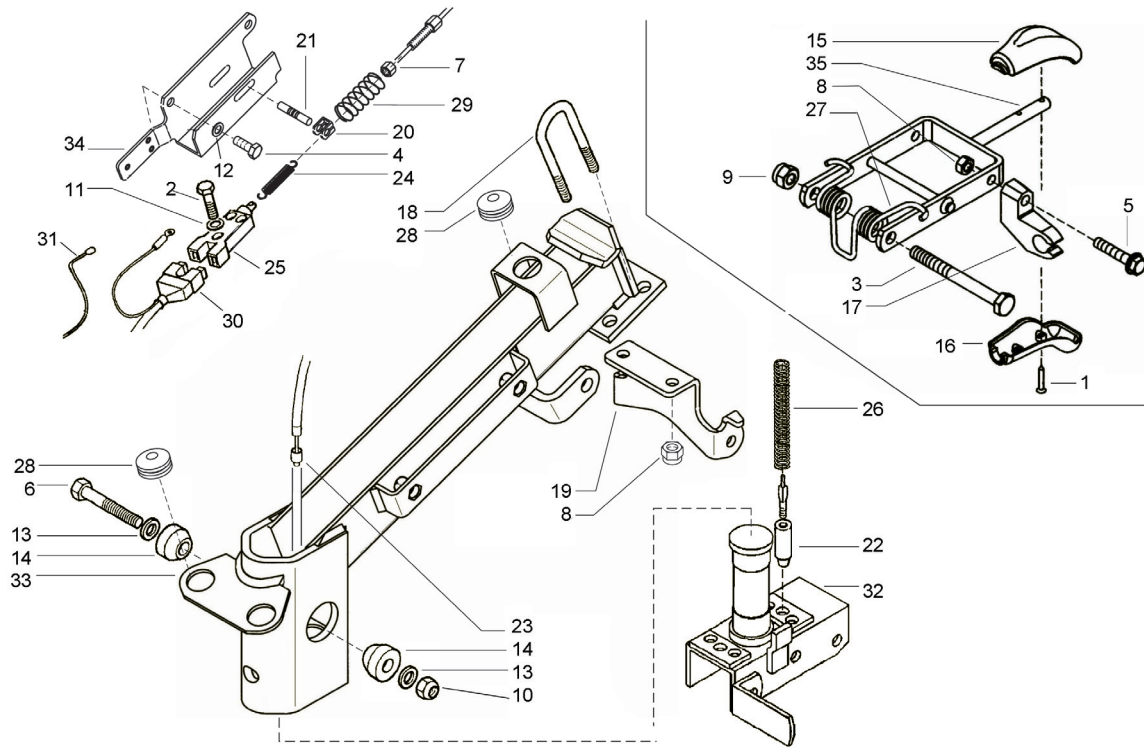

700-09.3

ID	PART NO	DESCRIPTION	ID	PART NO	DESCRIPTION
1	311.00451	SCREW 5X25	26	580.56918	SPRING, STEERING COLUMN
2	311.11086	CAP SCREW, M4.7X25	27	580.56942	HANDLEBAR RELEASE SPRING
3	311.11229	CAP SCREW, M10X110	28	580.56991	SUPPORT CAP
4	311.12150	CAP SCREW, MX20	29	580.57413	CHECK SPRING, MOTOR STOP
5	311.12165	SCREW	30	580.57417	MOTOR STOP WIRING
6	311.12293	CAP SCREW, M12X80	31	580.57419	WIRE, GROUND FOR S/N 794196+
7	312.11080	NUT, M8	32	590.56952	SUPPORT
8	312.41080	LOCK NUT, M8	33	592.56999	STEERING COLUMN
9	312.41100	LOCK NUT, M10	34	592.57409	SUPPORT, ENGINE STOP
10	312.41126	LOCK NUT, M12 DEFORMED	35	590.57010N	LEVER, HANDLEBAR SELECTION
11	314.11043	WASHER, FLAT, M4			
12	314.21083	WASHER, SUPER M8			
13	314.21100	SPRING WASHER			
14	521.56917	WEDGE			
15	551.57212	UPPER HANDLE HALF, BLACK			
16	551.57213	LOWER HANDLE HALF, BLACK			
17	552.43340	SUPPORT, CONTROL ROD			
18	561.56940	U BOLT			
19	561.56974	BRACKET			
20	561.57411	MOTOR STOP FORK			
21	561.57412	SPRING CHECK PIN			
22	563.56924	CAP			
23	580.42167	SHEATH END			
24	580.47712	SPRING, STOP			
25	580.48009	STOP SWITCH			

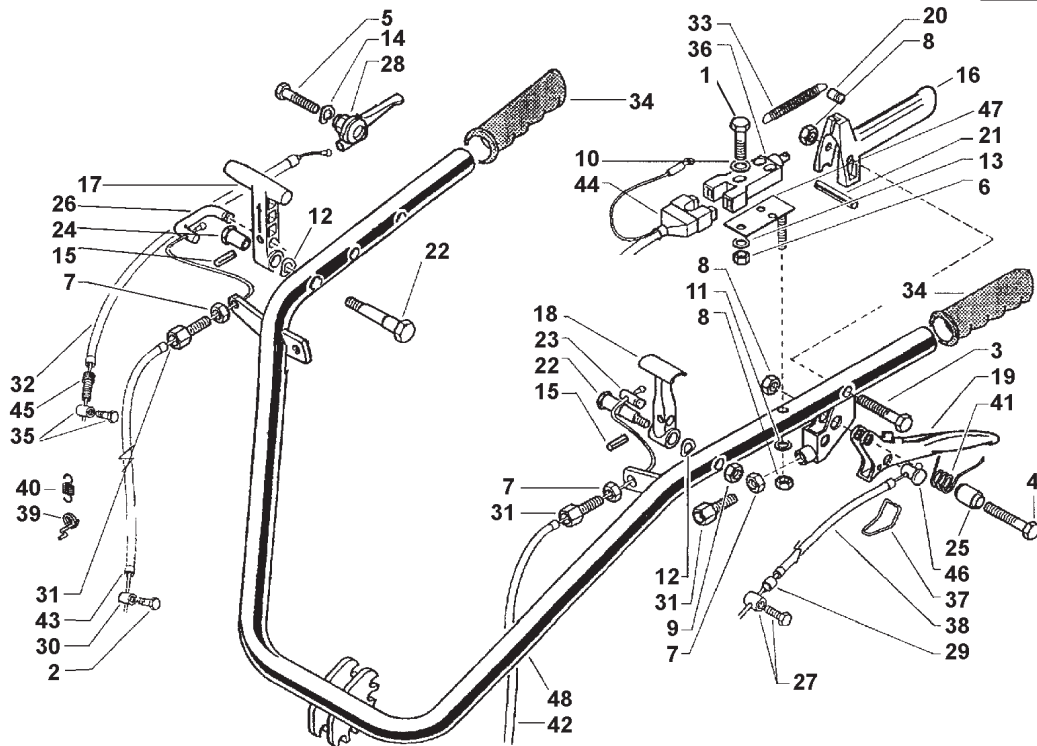

700.11.0-11.1

ID	PART NO	DESCRIPTION	ID	PART NO	DESCRIPTION
1	311.11086	CAP SCREW, M4X25	26	561.57332	PIN, REVERSE CABLE
2	311.11091	CAP SCREW, M6X14	27	580.02429	CLAMP, CABLE
3	311.11097	CAP SCREW, TE M6X14	28	580.02538	LEVER, ACCELERATOR
4	311.12089	CAP SCREW, M6X25	29	580.42167	SHEATH END
5	311.12153	CAP SCREW, M8X35	30	580.42200	PIN, CABLE CLAMP
6	312.11040	NUT, M4	31	580.42202	SCREW, M8 ADJUSTING
7	312.11080	NUT, M8	32	580.43219	CABLE
8	312.41060	LOCK NUT, M6	33	580.47712	SPRING
9	312.41080	LOCK NUT, M8	34	580.48000	GRIP
10	314.11043	WASHER, FLAT M4.3X19	35	580.48002	CLAMP, CABLE
11	314.11064	WASHER, FLAT M6X12.5	36	580.48009	SAFETY INTERLOCK
12	314.11084	WASHER, FLAT M8.4X17	37	580.51670	STOP WIRE
13	314.23043	WASHER, LOCK M4.3	38	580.53035	CABLE
14	314.23084	WASHER, LOCK M8.4X17	39	580.56158	SPRING
15	342.13020	PIN, SPLIT, M4X20 SPIROL	40	580.56164	SPRING
16	552.48041	LEVER, MOTOR STOP	41	580.56593	SPRING
17	552.48283	LEVER, REVERSER	42	580.57284	CABLE WITH SHEATH
18	552.48284	LEVER, STEERING COL. RELEASE	43	580.57329	CABLE, REVERSE
19	561.47655	LEVER, CLUTCH	44	580.57401	WIRE HARNESS
20	561.47711	PIN, LATCH	45	581.47704	SCREW, M6 ADJUSTING
21	561.48037	PIN	46	581.50313	BARREL
22	561.48285	PIN	47	590.47709	PLATE, INTERLOCK
23	561.48286	PIN, DRILLED	48	590.57116	HANDLEBAR COMPLETE
24	561.48287	BUSHING			
25	561.50361	SPACER, LEVER			



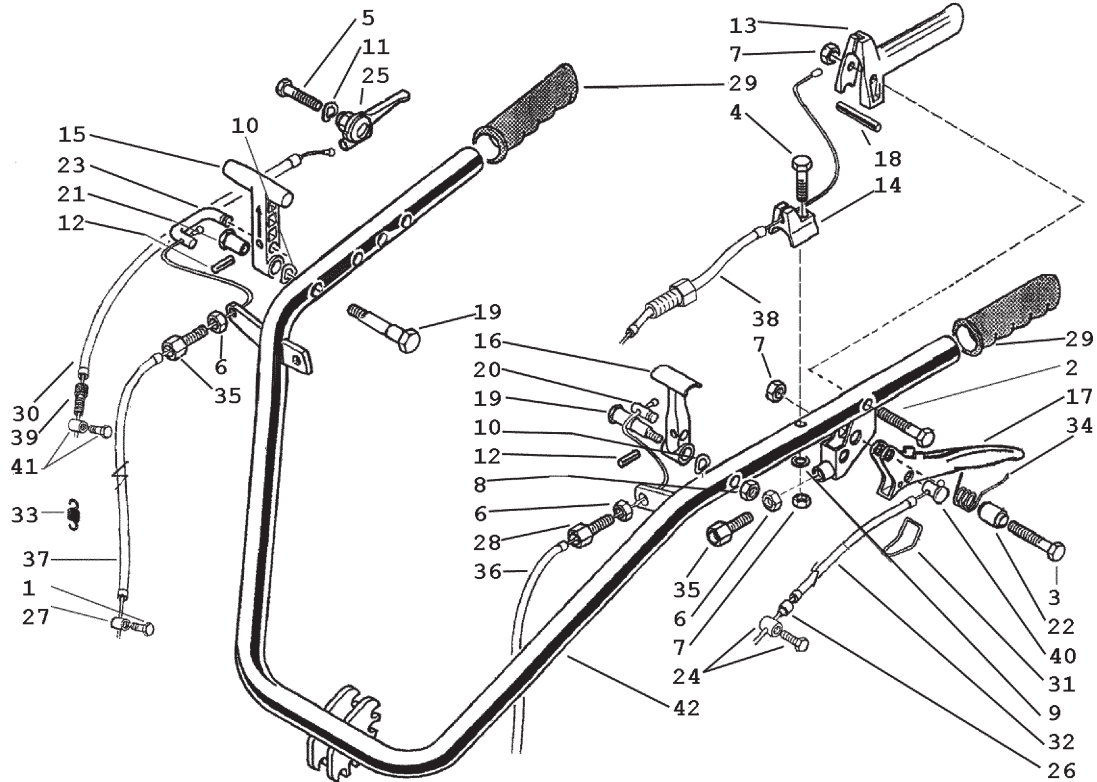

700.11.2-11.4

ID	PART NO	DESCRIPTION	ID	PART NO	DESCRIPTION
1	311.12090	CAP SCREW, M6X16	26	580.42167	SHEATH END
2	311.11097	CAP SCREW, M6X45	27	580.42200	CLAMP
3	311.12089	CAP SCREW, M6X25	28	580.42202	SCREW, ADJUSTING M8
4	311.12092	CAP SCREW, M6X35	29	580.48000	GRIP
5	311.12153	CAP SCREW, M8X35	30	580.48012	CABLE, ACCELERATOR, 73SHX79
6	312.11080	NUT, M8	31	580.51670	STOP WIRE
7	312.41060	LOCK NUT, M6	32	580.53035	CABLE
8	312.41080	LOCK NUT, M8	33	580.56155	SPRING
9	314.11064	FLAT WASHER, M6	34	580.56593	SPRING
10	314.11084	FLAT WASHER, M8	35	580.56595	SCREW, ADJUSTMENT
11	314.23084	LOCK WASHER, M8.4	36	580.57284	CABLE & SHEATH, STEERING COLUMN RELEASE
12	342.13020	PIN, SPLIT, M4 X 20 SPIROL	37	580.57329	CABLE AND SHEATH
13	552.48041	LEVER, MOTOR STOP	38	580.57416	CABLE, MOTOR STOP
14	552.48038	GUIDE, CABLE	39	581.47704	SCREW, ADJUSTING M6
15	552.48283	LEVER, REVERSER			
16	552.48284	LEVER, STEERING COL. RELEASE	40	581.50313	BARREL
17	561.47655	LEVER, CLUTCH	41	581.56156	CLAMP
18	561.48037	PIN	42	592.57151	HANDLEBAR COMPLETE
19	561.48285	PIN			
20	561.48286	DRILLED PIN			
21	561.48287	BUSHING, REVERSE LEVER			
22	561.50361	LEVER, SPACER			
23	561.57332	PIN, REVERSE CABLE			
24	580.02429	CABLE CLAMP			
25	580.02538	ACCELERATOR LEVER			

Revised 07/15/2014

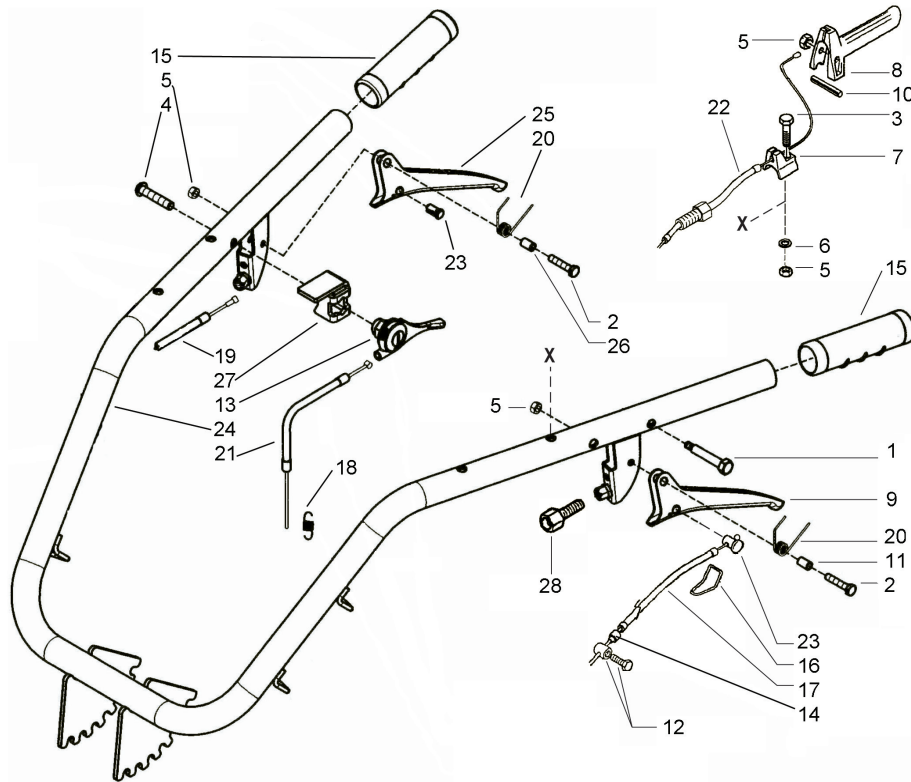

700.11.5

ID	PART NO	DESCRIPTION	ID	PART NO	DESCRIPTION
1	311.11097	CAP SCREW, M6 X 45	16	580.51670	STOP WIRE
2	311.12089	CAP SCREW, M6 X 25	17	580.53035	CABLE
3	311.12092	CAP SCREW, M6 X 35	18	580.56155	SPRING
4	311.21020	SCREW	19	580.56193	CABLE
5	312.41060	LOCK NUT, M6	20	580.56593	SPRING
6	314.11064	FLAT WASHER, M6	21	580.56815	CABLE & SHEATH
7	552.48038	GUIDE, CABLE	22	580.57416	CABLE, MOTOR STOP
8	552.48041	LEVER, MOTOR STOP	23	581.50313	BARREL
9	561.47655	LEVER, CLUTCH	24	592.57162	HANDLEBAR COMPLETE
10	561.48037	PIN	25	561.48470N	LEVER
11	561.50361	LEVER, SPACER	26	561.56603Z	SPACER
12	580.02429	CABLE CLAMP	27	561.56874N	PANEL
13	580.02538	LEVER, THROTTLE	28	580.56595	SCREW, ADJUSTING
14	580.42167	SHEATH END			
15	580.48000	GRIP			

Revised 01/10/2012

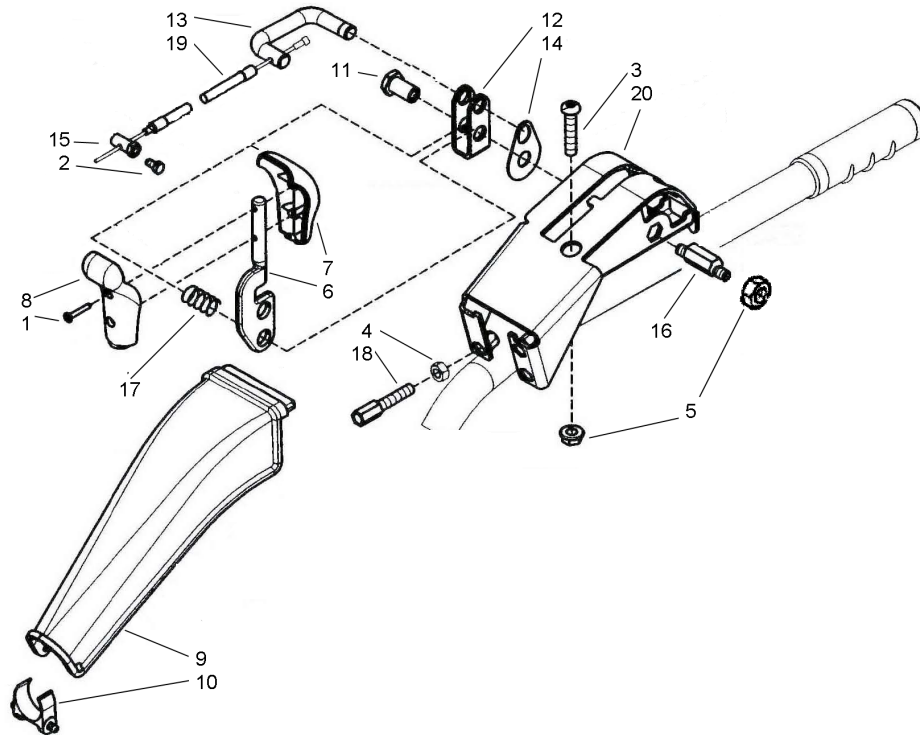

700.11.A.0

ID	PART NO	DESCRIPTION	ID	PART NO	DESCRIPTION
1	311.00451	SCREW 5X26	11	561.48287	BUSHING, REVERSE LEVER
2	311.12090	CAP SCREW, M6X16	12	561.56859Z	FORK
3	311.21020	SCREW	13	561.56832Z	ANCHOR
4	312.11080	NUT	14	563.56833Z	PLATE, SMALL
5	312.41084	NUT	15	563.56840Z	SCREW, CLAMPING
6	521.56810Z	LEVER	16	563.56858Z	PIN
7	551.57214	UPPER HANDLE HALF, RED	17	580.49830	SPRING
8	551.57215	LOWER HANDLE HALF, RED	18	580.56595	ADJUSTER
9	552.56835	COVER	19	580.56848	CABLE & SHEATH
10	552.56836	CROSS PIECE	20	592.56850	SUPPORT

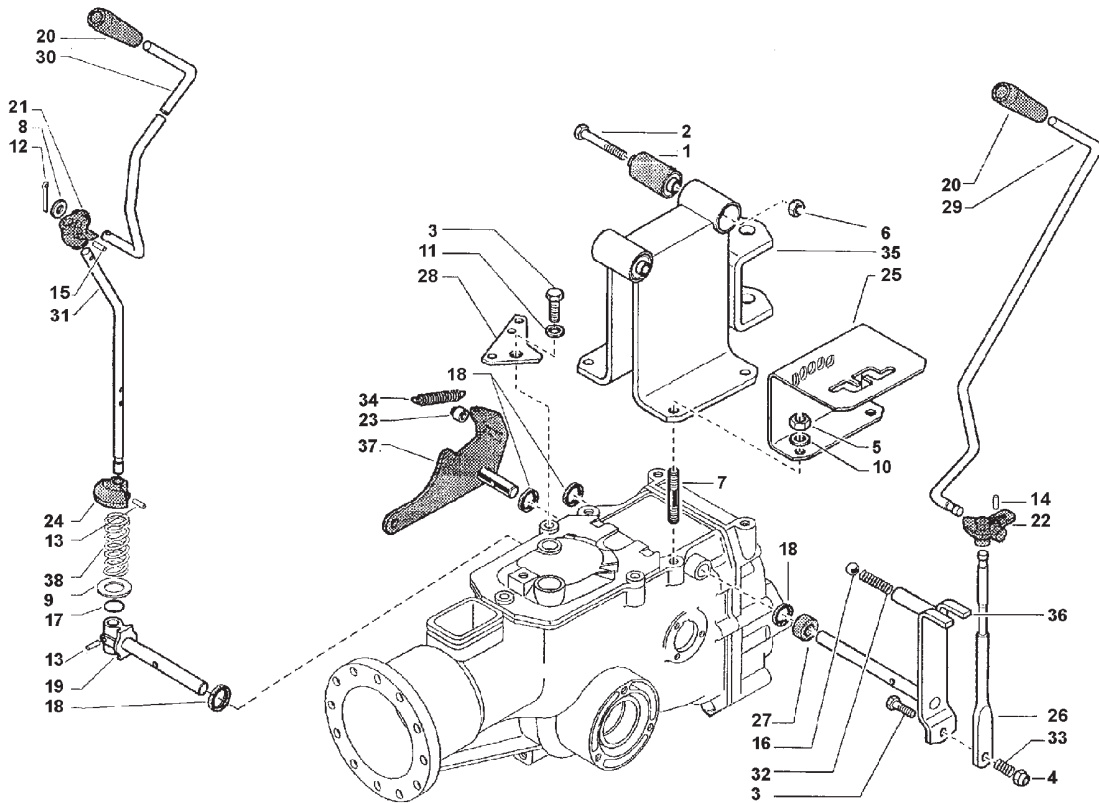

700.13.0

ID	PART NO	DESCRIPTION	ID	PART NO	DESCRIPTION
1	300.10142	SILENT BLOCK	21	552.48379	PTO ARTICULATOR
2	311.11217	CAP SCREW, M10X75	22	552.57249	SPEED ARTICULATOR
3	311.12152	CAP SCREW, M8X30	23	552.57313	PIN, PTO LOCKOUT
4	312.41080	LOCK NUT, M8	24	552.57321	PTO LOCKOUT
5	312.41085	LOCK NUT, M8 DEFORMED	25	561.57236	GEAR SELECTOR 3+2
6	312.41100	LOCK NUT, M10	26	561.57248	LEVER, SPEED CONTROL
7	313.12082	STUD, M8X35X14X20	27	561.57257	SPACER
8	314.11104	WASHER, FLAT M10.5X8	28	561.57274	REVERSE BRACKET
9	314.14130	WASHER, FLAT M13	29	561.57311	ROD, SPEED
10	314.21083	WASHER, SUPER M8	30	561.57312	ROD, PTO
11	314.23084	WASHER, LOCK M8.4 DIN13	31	561.57324	SHIFT ARM, PTO
12	341.10028	PIN, COTTER A 2X15	32	580.43176	SPRING
13	342.13020	PIN, SPLIT 4X20 SPIROL	33	580.57232	SPRING
14	342.13022	PIN, SPLIT 3X22 SPIROL	34	580.57273	SPRING
15	342.13024	PIN, SPLIT 4X24 SPIROL	35	590.56920	SUPPORT, HANDLEBAR
16	379.11532	BALL 15/32	36	590.57251	GEAR LEVER 3+2
17	381.11191	O-RING	37	590.57319	LEVER, PTO LOCKOUT
18	382.11400	OIL SEAL M14X22X4	38	F0831193010	SPRING
19	523.57250	PTO SHAFT			
20	551.42076	KNOB			

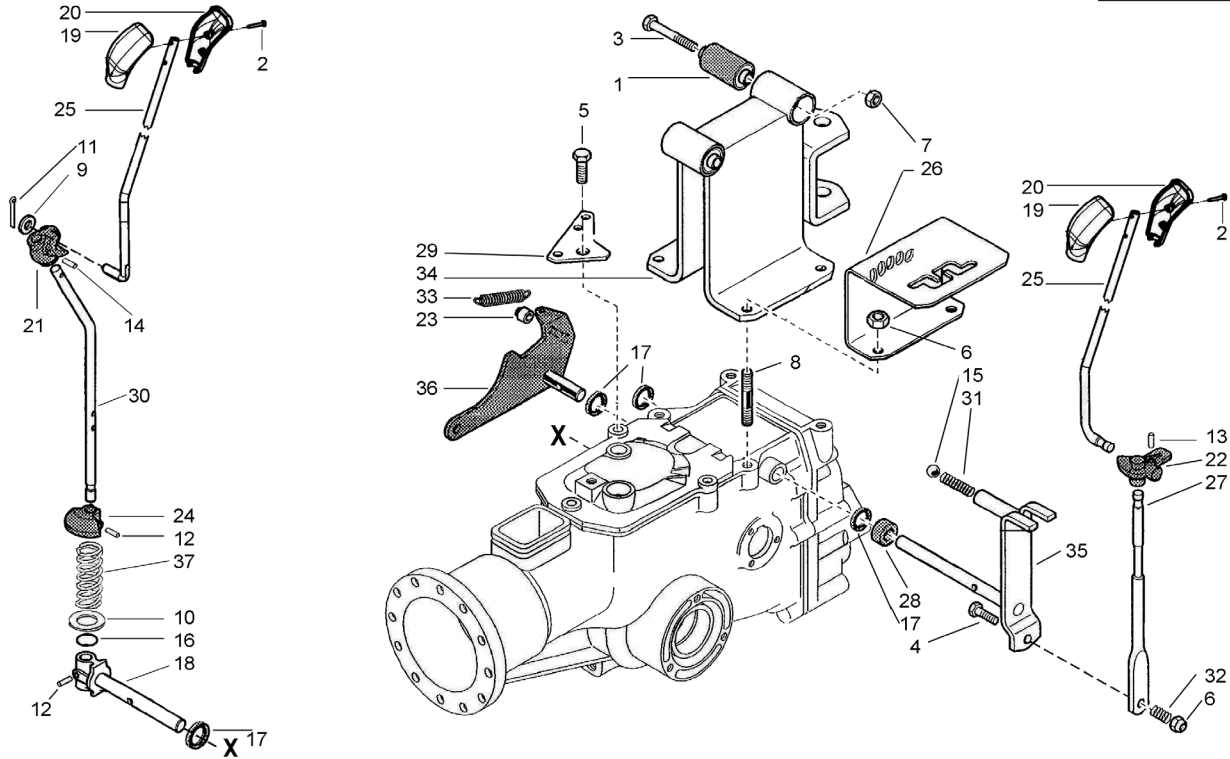

700.13.1

ID	PART NO	DESCRIPTION	ID	PART NO	DESCRIPTION
1	300.10142	SILENT BLOCK	26	561.57236	GEAR SELECTOR 3+2
2	311.00451	SCREW	27	561.57248	LEVER, SPEED CONTROL
3	311.11217	CAP SCREW, M10X75	28	561.57257	SPACER
4	311.12152	CAP SCREW, M8X30	29	561.57274	REVERSE BRACKET
5	311.12167	SCREW	30	561.57324	SHIFT ARM, PTO
6	312.41084	LOCK NUT, M8	31	580.43176	SPRING
7	312.41100	LOCK NUT, M10	32	580.57232	SPRING
8	313.12082	STUD, M8X35X14X20	33	580.57273	SPRING
9	314.11104	WASHER, FLAT M10.5X8	34	590.56920	SUPPORT, HANDLEBAR
10	314.14130	WASHER, FLAT M13	35	590.57251	GEAR LEVER 3+2
11	341.10028	PIN, COTTER A 2X15	36	590.57319	LEVER, PTO LOCKOUT
12	342.13020	PIN, SPLIT 4X20 SPIROL	37	F0831193010	SPRING
13	342.13022	PIN, SPLIT 3X22 SPIROL			
14	342.13024	PIN, SPLIT 4X24 SPIROL			
15	379.11532	BALL 15/32			
16	381.11191	O-RING			
17	382.11400	OIL SEAL M14X22X4			
18	523.57250	PTO SHAFT			
19	551.57212	UPPER HDLE.REL.KNOB BLACK			
20	551.57213	LOWER HDLE.REL. KNOB BLACK			
21	552.48379	PTO ARTICULATOR			
22	552.57249	SPEED ARTICULATOR			
23	552.57313	PIN, PTO LOCKOUT			
24	552.57321	PTO LOCKOUT			
25	561.56792	CONTROL ROD			

Revised 01/10/2012

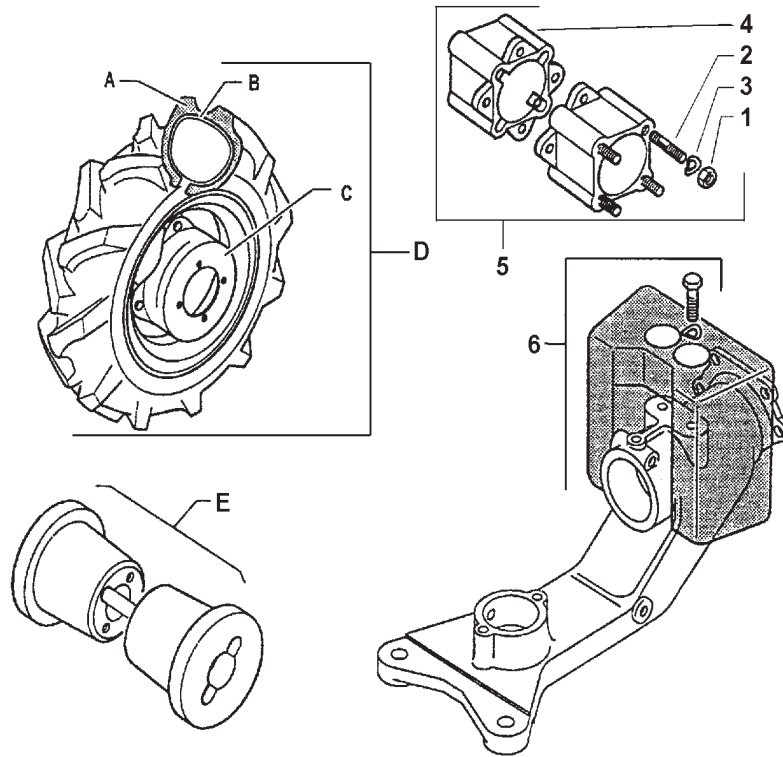

700.14.0

ID	PART NO	DESCRIPTION	ID	PART NO	DESCRIPTION
1	312.11100	NUT, M10	4	NSI	USE ITEM# 922.4385
2	313.12102	STUD, M10X40X24X12	5	922.43685	PAIR WHEEL EXTENSIONS COMPLETE
3	314.23105	WASHER, M10.5			
A	391.13502	TIRE 3.50 - 8"	D	922.57775	PAIR WHEELS COMPLETE
	391.14008	TIRE 4.00 - 8"		922.43680	PAIR WHEELS COMPLETE
	391.14010	TIRE 4.00 - 10"		922.48332	PAIR WHEELS COMPLETE
	391.15010	TIRE 5.00 - 10"		922.48334	PAIR WHEELS COMPLETE
	391.15012	TIRE 5.00 - 12"		922.44806	PAIR WHEELS COMPLETE
	391.16018	TIRE 6.50 - 12"		922.44809	PAIR WHEELS COMPLETE
B	394.13502	TUBE 3.50 - 8"			
	394.14008	TUBE 4.00 - 8"			
	394.14010	TUBE 4.00 - 10"			
	394.15010	TUBE 5.00 - 10"			
	394.15012	TUBE 5.00 - 12"			
	394.16018	TUBE 6.50 - 12"			
C	580.43250	RIM 3.50 - 8" & 4.00 - 8"			
	580.48330	RIM 4.00 - 10" & 5.00 - 10"			
	580.44804	RIM 5.00 - 12" & 6.50 - 12"			

**NSI - Not serviced  
individually**

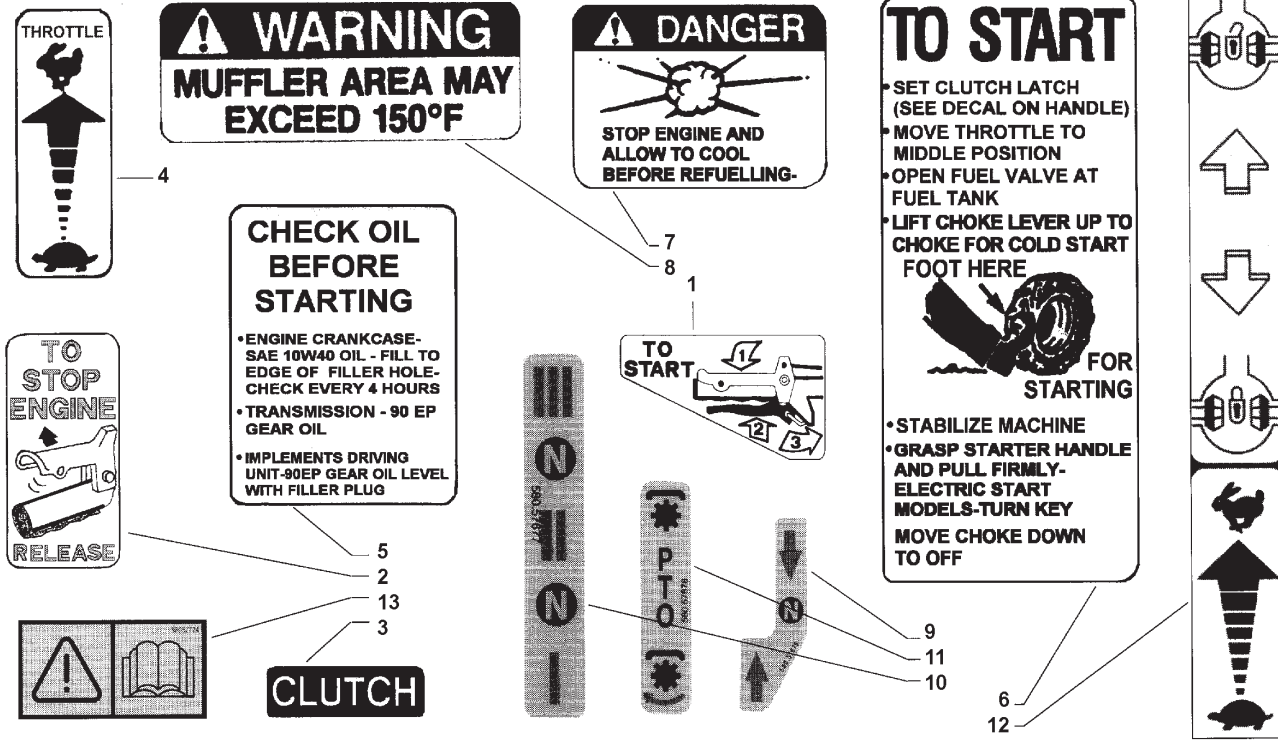

700.15.0

ID	PART NO	DESCRIPTION	ID	PART NO	DESCRIPTION
1	580.47950	DECAL, TO START			
2	580.47951	DECAL, ENGINE STOP			
3	580.47952	DECAL, CLUTCH			
4	580.47953	DECAL, THROTTLE			
5	580.47959	DECAL, CHECK OIL			
6	580.47960	DECAL, TO START			
7	580.47961	DECAL, DANGER			
8	580.47962	DECAL, WARNING			
9	580.57676	DECAL, NEUTRAL			
10	580.57677	DECAL, GEAR			
11	580.57678	DECAL, PTO			
12	580.57688	DECAL, DIFF & THROTTLE			
13	580.57724	DECAL, READ OP MANUAL			

Revised 01/10/2012



9



10



8

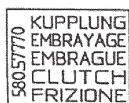

11



4



5



6

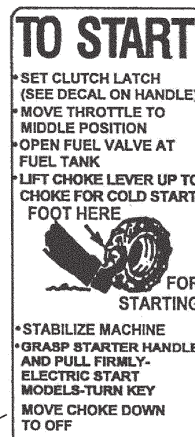

3

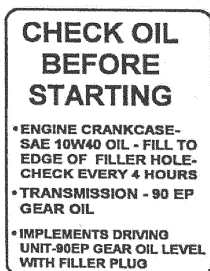

2



12



1



7

700.15.1

ID	PART NO	DESCRIPTION	ID	PART NO	DESCRIPTION
1	580.47953	DECAL, THROTTLE			
2	580.47959	DECAL, CHECK OIL			
3	580.47960	DECAL, TO START			
4	580.57676	DECAL, NEUTRAL			
5	580.57677	DECAL, GEAR			
6	580.57678	DECAL, PTO			
7	580.57688	DECAL, DIFF & THROTTLE			
8	580.57724	DECAL, READ OP MANUAL			
9	580.57767	DECAL, GEAR			
10	580.57768	DECAL, PTO			
11	580.57770	DECAL, CLUTCH			
12	580.57772	DECAL, OPERATOR PRESENCE			



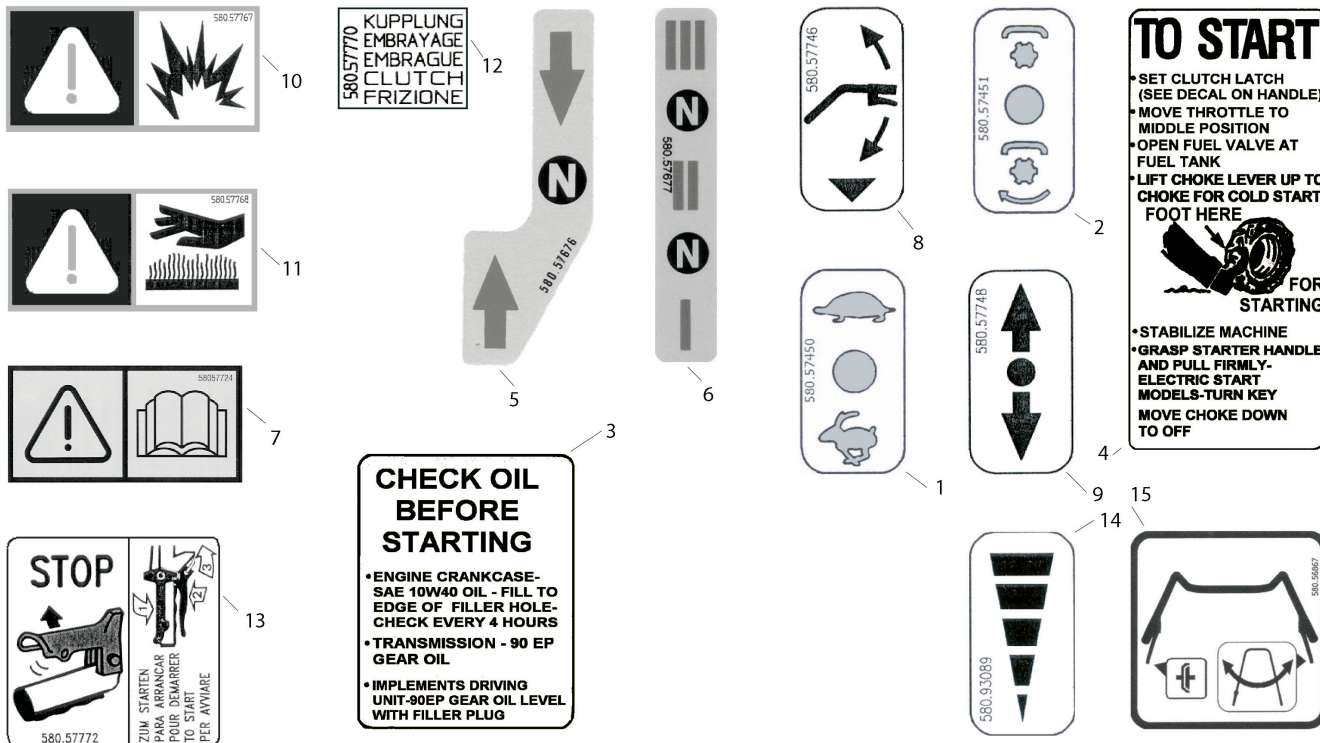

700-15.2

ID	PART NO	DESCRIPTION	ID	PART NO	DESCRIPTION
1	580.57450	DECAL, THROTTLE			
2	580.57451	DECAL			
3	580.47959	DECAL, CHECK OIL			
4	580.47960	DECAL, TO START			
5	580.57676	DECAL, NEUTRAL			
6	580.57677	DECAL, GEAR SELECT			
7	580.57724	DECAL, READ OP. MANUAL			
8	580.57746	DECAL, HEIGHT ADJ.			
9	580.57748	DECAL, FWD/REVERSE			
10	580.57767	DECAL			
11	580.57768	DECAL			
12	580.57770	DECAL, CLUTCH			
13	580.57772	DECAL, OPERATOR PRESENCE			
14	580.93089	DECAL			
15	580.56867	DECAL, HANDLE PIVOT			

# 722

**Decals, Logos & Unit Identification**

**Serial Number Range  
UP TO 01/2006**

# 12.00

Revised 01/10/2012

580.57762 **PROFESSIONAL**

580.57761 **HARVESTER**

580.57752 **712GX5**

580.57753 **712GX8**

580.57756 **732GX11**

580.57755 **722** — 7

580.57754 **718** — 6

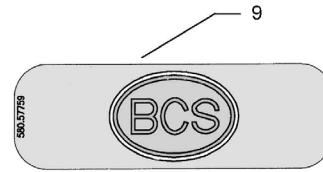

700.16.0

ID	PART NO	DESCRIPTION	ID	PART NO	DESCRIPTION
1	530.48656	DECAL, BCS LOGO			
2	580.57681	DECAL, 710			
3	580.57692	DECAL, GARDENER			
4	580.57752	DECAL, 712GX5			
5	580.57753	DECAL, 712GX8			
6	580.57754	DECAL, 718			
7	580.57755	DECAL, 722			
8	580.57756	DECAL, 732GX11			
9	580.57759	DECAL, BCS LOGO			
10	580.57761	DECAL, HARVESTER			
11	580.57762	DECAL, PROFESSIONAL			

Revised 01/10/2012

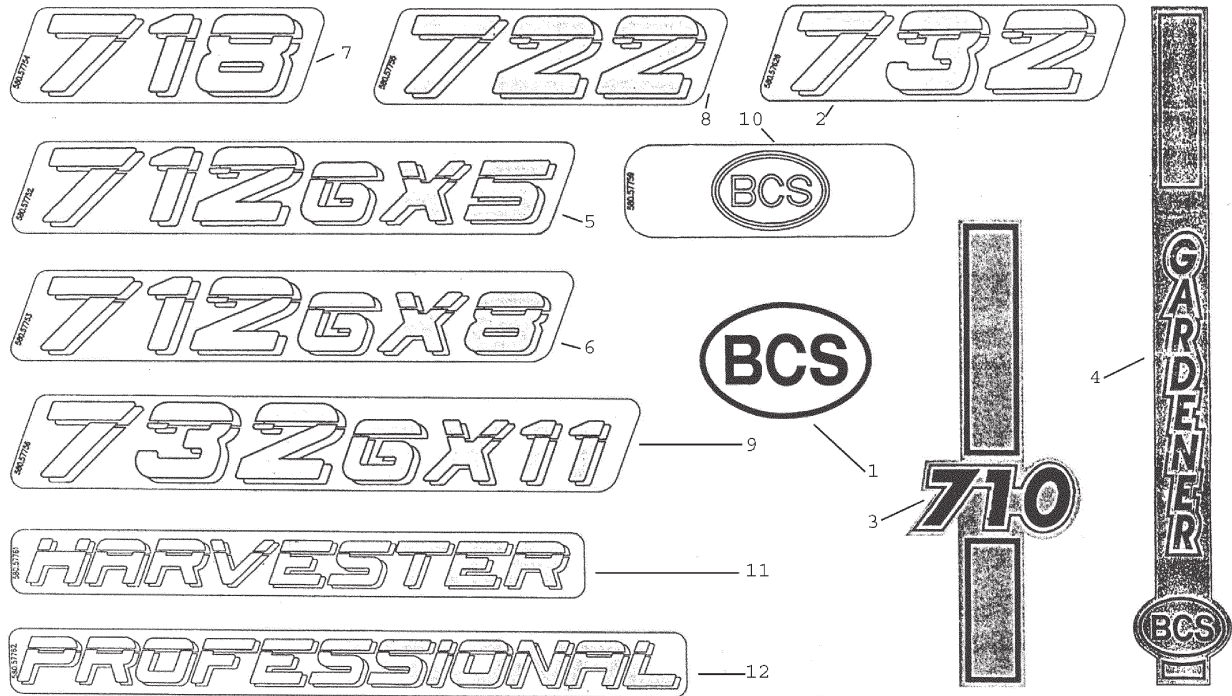

700.16.1

ID	PART NO	DESCRIPTION	ID	PART NO	DESCRIPTION
1	530.48656	DECAL, BCS LOGO			
2	580.57626	DECAL, 732			
3	580.57681	DECAL, 710			
4	580.57692	DECAL, GARDENER			
5	580.57752	DECAL, 712GX5			
6	580.57753	DECAL, 712GX8			
7	580.57754	DECAL, 718			
8	580.57755	DECAL, 722			
9	580.57756	DECAL, 732GX11			
10	580.57759	DECAL, BCS LOGO			
11	580.57761	DECAL, HARVESTER			
12	580.57762	DECAL, PROFESSIONAL			

Revised 01/10/2012



700-16.2

ID	PART NO	DESCRIPTION	ID	PART NO	DESCRIPTION
1	530.48656	DECAL, BCS LOGO			
2	580.58470	DECAL, 712GX5			
3	580.58471	DECAL, 712GX8			
4	580.58472	DECAL, 718			
5	580.58473	DECAL, 722			
6	580.58474	DECAL, 732GX11			
7	580.58475	DECAL, 732GX13			
8	580.58480	DECAL, RENTAL			
9	580.58481	DECAL, HARVESTER			
10	580.58482	DECAL, PROFESSIONAL			