



Naòs System

Sistema pensato per interpretare un nuovo concetto di spazio ufficio. Un ambiente costruito con rigorosa semplicità, dove l'impiego diffuso della tecnologia non è mai invasivo. Un paesaggio architettonico definito da presenze essenziali. Esili strutture monolitiche, che disegnano nuovi scenari per il lavoro. Innovative configurazioni a sviluppo lineare, costruite con elementi modulari, in grado di assicurare elevate prestazioni tecniche, flessibilità di utilizzo e grande comfort. Postazioni aggregate a spazio aperto, attrezzate per soddisfare esigenze funzionali specifiche: zone operative, uffici direzionali, biblioteche, sale riunioni... Un sistema in continua evoluzione, progettato per andare oltre.

System conceived to interpret a new concept of office space. A setting constructed with rigorous simplicity, in which the all-pervasive use of technology never makes its presence felt. An architectonic office-scape defined by essential presences. Slender monolithic structures, which design new scenarios for work. Innovative configurations, which are built up in a linear fashion, constructed with modular elements, capable of assuring consummate technical performance, utilitarian flexibility and matchless comfort. Clustered open-space workstations, equipped to satisfy specific functional needs - operative areas, executive offices, libraries, meeting rooms... A system in continuous evolution, designed to go far beyond the indispensable minimum.





Tavoli per ufficio. Elementi monolitici di grandi dimensioni, caratterizzati da forme essenziali, materiali selezionati, accurato studio dei particolari ed elevate prestazioni di stabilità e sicurezza. Soluzioni tipologiche innovative, realizzate con componenti modulari di un unico sistema costruttivo, capace di adeguarsi a situazioni diverse. Configurazioni operative a spazio aperto, aggregate a due, a quattro, a sei, a otto... Postazioni di lavoro in linea, attrezzate con pannelli divisorii, bracci di supporto per monitor e pratici sportelli di accesso alla canalizzazione sottopiano.

Tables for the office. Large-sized monolithic elements, characterized by essential forms, select materials, a painstaking study of detailing and surefire safety and stability. Innovative typological solutions, achieved with the modular components of a unique constructive system, capable of adapting to a wide variety of situations. Open-space operative configurations in clusters of two, four, six, eight... Workstations with a linear setup, equipped with dividing screens, monitor arm supports and practical windows giving access to under-top wire management solutions.

Il tavolo si configura come una struttura monolitica, costruita con elementi modulari in alluminio a sezione triangolare e rettangolare, assemblati mediante un particolare sistema di fissaggio, che assicura elevate prestazioni tecniche e di sicurezza. Il telaio di supporto orizzontale è appoggiato alle quattro gambe posizionate agli angoli, mentre al centro è sorretto da montanti collegati

al vassoio predisposto per la canalizzazione sottopiano. Tutta la struttura è realizzata in profilati di alluminio anodizzato con finitura lucida oppure opaca; a richiesta è disponibile anche la versione verniciata. Le postazioni di lavoro sono completate dalle cassettiere metalliche Neutra e da una linea di accessori funzionali che qualificano le varie tipologie.

The table is configured as a monolithic structure, constructed with modular elements in aluminium with triangular and rectangular cross-sections, assembled by means of a special anchoring system, which assures top-notch safety and technical performance. The horizontal support frame rests on four legs positioned at the corners, while it is supported at the center by

uprights connected to a tray for under-top wire management. The entire structure is made of anodized aluminium sections with a glossy or opaque finish. Also available, by request, is a painted version. The workstations are rounded out by metallic drawer pedestals Neutra and a range of functional accessories which complement the various styles.





Le postazioni operative sono separate da schermi vetriati, disponibili in due tipologie: gli elementi bassi sono realizzati in cristallo extrachiaro con bordo satinato e spessore di 19 mm, mentre quelli a media altezza sono costituiti da un pannello in vetrocamera acidato con telaio in policarbonato; entrambi si possono illuminare con un sistema di luci posizionate al di sotto dei pannelli. Studiati per proteggere maggiormente le postazioni e migliorarne l'insonorizzazione,

gli schermi sono inoltre predisposti per accogliere una serie di contenitori pensili (raccoglitori e vaschette) e un innovativo braccio snodato che consente il fissaggio e il corretto posizionamento dei monitor in dotazione a ogni postazione. Disponibile anche nella versione a doppio snodo, il braccio di supporto si sposta facilmente lungo il pannello divisorio ed è perfettamente regolabile mediante semplici dispositivi di movimento e registrazione in altezza, inclinazione e rotazione.

Workstations are divided by two types of glass screens: the low elements are made in extra-clear glass with a matte border and are 19mm thick, while the medium height screens feature an etched double-glazed panel with a polycarbonate frame; both types of screens can be illuminated by a system of lights positioned under the panels. Designed to provide more protection to workstations and to improve soundproofing, the screens are also able to hold a series of suspended containers

(file storage and trays) and include an innovative articulated arm which enables the monitors provided at each workstation to be correctly positioned and secured. The support arm is also available in a two-way adjustable version and glides smoothly along the partition. Easy-to-use devices adjust the height, inclination and rotation of the monitor.



Una parete libreria e grandi tavoli definiscono lo spazio biblioteca. Un ambiente aperto, luminoso e confortevole, pensato per attività di studio, lettura, consultazione, ricerca individuale e di gruppo. Ogni postazione dispone di un'ampia superficie di utilizzo, attrezzata con dotazioni funzionali specifiche: lampade con luce diretta sul piano di lavoro, vassoio sottostante ispezionabile per la distribuzione degli impianti, sportelli di servizio per l'alimentazione delle strumentazioni informatiche.

A bookcase wall and large tables lend definition to the library space. An open environment, which is luminous and comfortable. It was conceived for study, reading, and consultation activities, as well as individual and group research. Every workstation has a large usable surface, equipped with specific functional features - lamps that shed a direct light on the worktop, an underlying tray that is easily accessible for wire management and service windows for supplying power to computing instrumentation.

Il piano di lavoro è realizzato in cristallo extrachiaro acidato, temperato e retroverniciato bianco; disponibile a richiesta anche con altri materiali di finitura (Forbo linoleum desk top, nero o grigio; legno sicomoro naturale; laminato bianco). I tavoli sono dotati di sportelli ribaltabili a 180°, che consentono di accedere

comodamente al vassoio sottostante, predisposto per la canalizzazione degli impianti. Le postazioni possono essere attrezzate con accessori funzionali che qualificano le varie tipologie: i tavoli biblioteca sono dotati di lampade a luce diretta sul piano, mentre le versioni operative sono caratterizzate dai pannelli divisorii.

The work top is made of etched, ultra-white plate glass, that has been toughened and painted white. Also available, by request, with other finishing materials (black or grey Forbo linoleum desk top; natural sycamore wood; white laminate). The tables come equipped with windows that can be tipped up to an angle of 180°, which enable the user to get at

the underlying tray, designed for wire management, with the greatest of ease. Workstations can be equipped with functional accessories that qualify the various typologies: library table-tops are supplied with direct-light lamps, while operative versions are characterized by panel dividers.





Il tavolo biblioteca è caratterizzato dalla lampada a luce diretta, posizionata al centro, lungo la mezzera. Il corpo illuminante, realizzato in profilato di alluminio verniciato, è sostenuto da esili montanti, che assolvono anche la funzione di alimentazione elettrica. Al di sotto del piano, si trova

il vassoio predisposto per la canalizzazione degli impianti, al quale si accede comodamente attraverso gli sportelli (ribaltabili di 180°) ricavati nel piano del tavolo. L'allacciamento alla rete (elettrica, telefonica, dati ecc.) avviene mediante il collegamento canalizzato tra vassoio sottopiano e montanti strutturali centrali.

The library table is characterized by a direct-light lamp, positioned in the center, along the center line. The lighting body, made of painted aluminium section, is held up by slender uprights, that also carry out the function of supplying electricity. Underneath the top is a tray for wire management, which can be

easily accessed through windows (that can be tipped up to 180 degrees), carved into the top of the table. Connection to the network (electric, telephonic, data etc.) is done through a channelized link between under-top tray and central structural uprights.





Tavolo caratterizzato da un'ampia superficie di utilizzo, con piano di lavoro in cristallo extrachiario retroverniciato bianco. Prodotto in tre formati modulari e disponibile (a richiesta) anche con altri materiali di finitura (linoleum, sicomoro, laminato). Dotato di canalizzazione sottopiano, accessibile mediante uno sportello di servizio (ribaltabile di 180°), che consente di alimentare le strumentazioni elettroniche della postazione. Schermi divisorii attrezzati e lampade a luce diretta qualificano la versione operativa e il tavolo biblioteca.

Table characterized by a broad, usable surface, with a work top in ultra-clear plate glass, painted white. Produced in three modular sizes and available (by request) with other finishing materials (linoleum, sycamore and laminate). Equipped with under-top raceways and accessible by means of a service window (which can be tipped up to an angle of 180°), making it possible to supply the electronic instrumentation on the workstation. Equipped screen dividers and direct-light lamps qualify the operative version and the library table.

Il sistema si articola in tre tipologie funzionali: il tavolo riunioni, completamente libero, il tavolo operativo, dotato di schermo divisorio trasparente, e il tavolo biblioteca, attrezzato con lampada a luce diretta sul piano. Ogni tipologia si sviluppa in linea secondo tre moduli base (cm 150x150, 180x180, 210x210), nelle configurazioni aggregate a due, quattro, sei, otto postazioni.

The system comprises three functional typologies: the meeting table, which is completely free, the operative table, provided with transparent screen dividers and the library table, equipped with a direct-light lamp on the top. Every typology is worked out in a linear fashion, in accordance with three basic modules (150x150, 180x180, 210x210 cms.), in configurations of two, four, six and eight workstations.





Struttura modulare realizzata in profilati di alluminio anodizzato, a sezione triangolare, con finitura lucida oppure opaca (a richiesta verniciata). Telaio portante appoggiato alle quattro estremità e ai sostegni centrali, in modo da consentire ampia libertà nei movimenti. Montanti interni e vassoio sottopiano predisposti per la risalita e la distribuzione dei cavi di alimentazione elettrica. Sistema di assemblaggio sicuro e funzionale. Materiali selezionati e studio accurato dei particolari. Soluzioni costruttive semplici e innovative, in grado di garantire elevate prestazioni tecniche, flessibilità di utilizzo e grande leggerezza formale.

Modular structure made of anodized aluminium sections, with a triangular cross-section and a glossy or opaque finish (painted, by request). Support frame rests on its four extremities and central supports, so as to give users the ultimate in freedom of movement. Internal uprights and undertop tray are designed to handle the rise and distribution of electrical supply wiring. Functional and surefire assembly system. Select materials and scrupulous research on detail work. Simple and innovative constructive solutions, capable of guaranteeing world-class technical performance, utilitarian flexibility and eye-pleasing formal lightness.

Il programma è completato da una serie di scrivanie singole, pensate per rispondere alle esigenze degli spazi direttivi, professionali e di servizio, per gli uffici direzionali e per piccole sale riunioni. Realizzata con le stesse finiture e caratteristiche costruttive delle tipologie aggregate, la

postazione operativa individuale è disponibile in tre versioni dimensionali, tutte con vano di servizio per l'alimentazione delle strumentazioni elettroniche, posizionato sottopiano e accessibile mediante uno sportello laterale ribaltabile a 180°.

The program is rounded out by a series of individual desks, conceived to respond to the needs of managerial, professional and service spaces, for executive offices and small conference rooms. Made with the same finishes and constructive characteristics as clustered

typologies, the individual operative workstation is available in three dimensional versions, all with a service bay for the supply of electronic instrumentation, positioned under-top and accessible by means of a lateral window, which can be tipped up to an angle of 180 degrees.





La scrivania operativa singola, disponibile in tre formati (cm 90x180, 90x210, 120x180), è caratterizzata dal vano tecnico posizionato sotto il piano, accessibile mediante lo sportello ribaltabile laterale, che consente l'alimentazione di tutte le strumentazioni

tecnologiche e di servizio in dotazione alla postazione di lavoro; l'allacciamento alla rete (elettrica, telefonica, dati ecc.) avviene tramite il passaggio dei cavi attraverso una speciale canalizzazione ricavata all'interno di una gamba.

The single desk, available in three sizes, (cm 90x180, 90x210, 120x180), features a compartment located under the work surface, accessed by means of a lateral window on one side, which holds all of the power cables for the technological and service equipment used by the

workstation; this compartment is connected to the mains and other systems (electricity, telephone, data transmission) by means of a special conduit inside the table leg.

NaosSystem

Y | N | 1 | 1 | 5 | 0 | 1 | 5 | 0 | P | I | |
Y | N | 1 | 1 | 5 | 0 | 1 | 5 | 0 | S | T | |

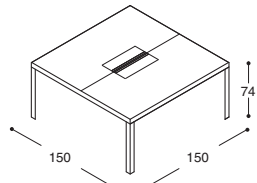

Y | N | 2 | 1 | 5 | 0 | 1 | 5 | 0 | P | I | |
Y | N | 2 | 1 | 5 | 0 | 1 | 5 | 0 | S | T | |

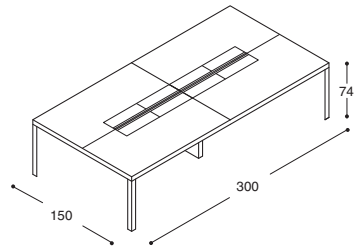

Y | N | 3 | 1 | 5 | 0 | 1 | 5 | 0 | P | I | |
Y | N | 3 | 1 | 5 | 0 | 1 | 5 | 0 | S | T | |

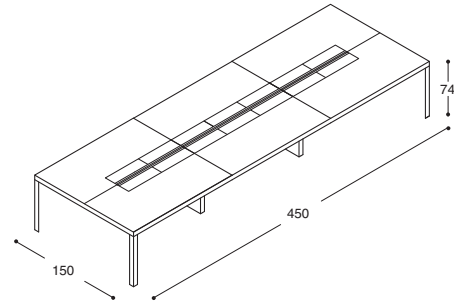

Y | N | 4 | 1 | 5 | 0 | 1 | 5 | 0 | P | I | |
Y | N | 4 | 1 | 5 | 0 | 1 | 5 | 0 | S | T | |

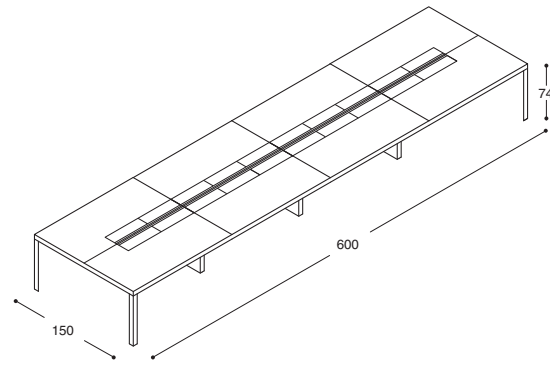

Y | N | 1 | 1 | 8 | 0 | 1 | 8 | 0 | P | I | |
Y | N | 1 | 1 | 8 | 0 | 1 | 8 | 0 | S | T | |

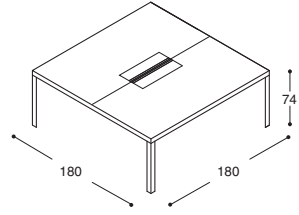

Y | N | 2 | 1 | 8 | 0 | 1 | 8 | 0 | P | I | |
Y | N | 2 | 1 | 8 | 0 | 1 | 8 | 0 | S | T | |

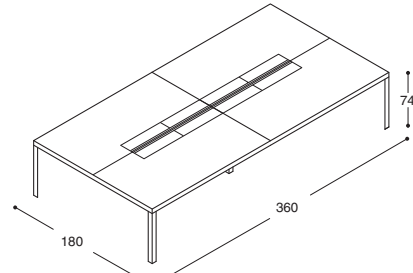

Y | N | 3 | 1 | 8 | 0 | 1 | 8 | 0 | P | I | |
Y | N | 3 | 1 | 8 | 0 | 1 | 8 | 0 | S | T | |

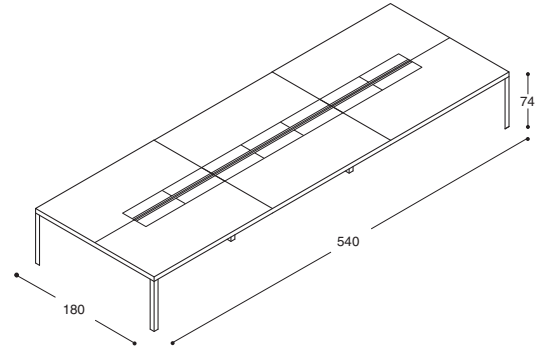

Y | N | 4 | 1 | 8 | 0 | 1 | 8 | 0 | P | I | |
Y | N | 4 | 1 | 8 | 0 | 1 | 8 | 0 | S | T | |

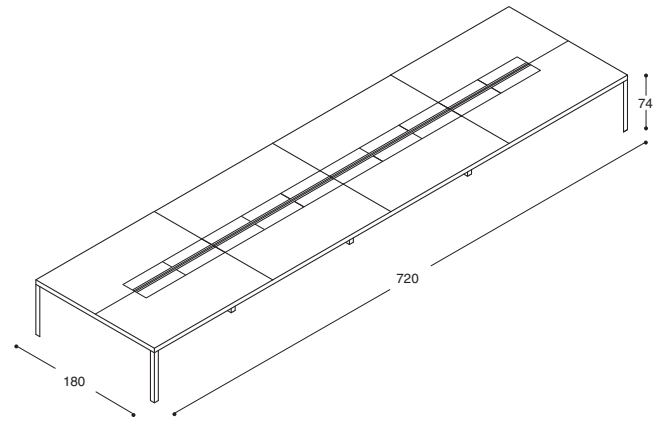

Y | N | 1 | 2 | 1 | 0 | 2 | 1 | 0 | P | I | |
Y | N | 1 | 2 | 1 | 0 | 2 | 1 | 0 | S | T | |

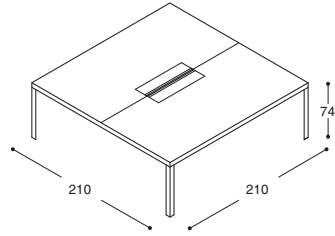

Y | N | 2 | 2 | 1 | 0 | 2 | 1 | 0 | P | I | |
Y | N | 2 | 2 | 1 | 0 | 2 | 1 | 0 | S | T | |

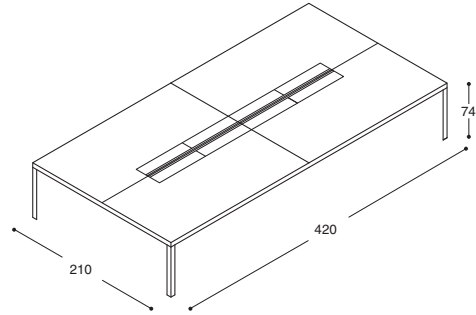

Y | N | 3 | 2 | 1 | 0 | 2 | 1 | 0 | P | I | |
Y | N | 3 | 2 | 1 | 0 | 2 | 1 | 0 | S | T | |

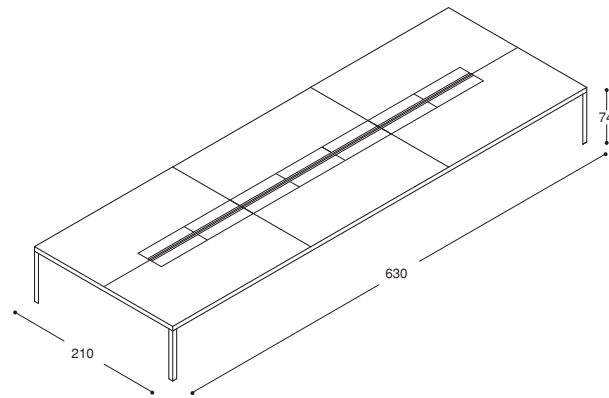

Y | N | 4 | 2 | 1 | 0 | 2 | 1 | 0 | P | I | |
Y | N | 4 | 2 | 1 | 0 | 2 | 1 | 0 | S | T | |

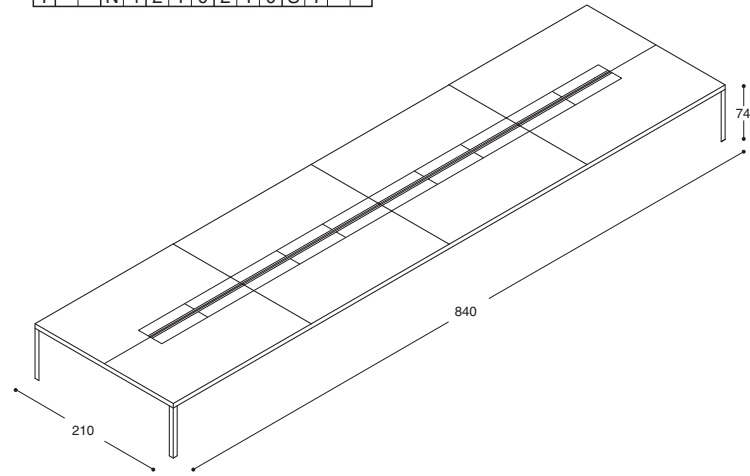

Y | N | Y | 1 | 8 | 0 | 0 | 9 | 0 | P | I | |
Y | N | Y | 1 | 8 | 0 | 0 | 9 | 0 | S | T | |

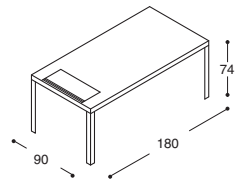

Y | N | Y | 2 | 1 | 0 | 0 | 9 | 0 | P | I | |
Y | N | Y | 2 | 1 | 0 | 0 | 9 | 0 | S | T | |

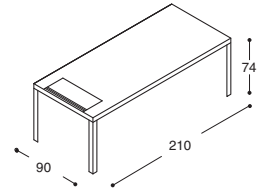

Y | N | Y | 1 | 8 | 0 | 1 | 2 | 0 | P | I | |
Y | N | Y | 1 | 8 | 0 | 1 | 2 | 0 | S | T | |

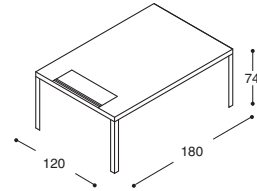

Y N 2 1 5 0 S 1 7
Y N 3 1 5 0 S 1 7
Y N 4 1 5 0 S 1 7
Schermo/Screen
Y N 2 1 5 0 L U
Y N 3 1 5 0 L U
Y N 4 1 5 0 L U
Luce sottopiano/Undertop light

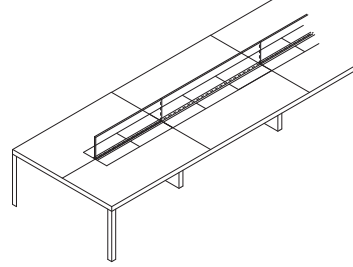

Y N 2 1 5 0 P 3 6
Y N 3 1 5 0 P 3 6
Y N 4 1 5 0 P 3 6
Schermo alto/High screen
Y N 2 1 5 0 L U
Y N 3 1 5 0 L U
Y N 4 1 5 0 L U
Luce sottopiano/Undertop light

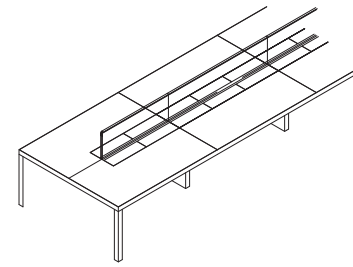

Y N 2 1 5 0 L T
Y N 3 1 5 0 L T
Y N 4 1 5 0 L T
Lampada/Lamp

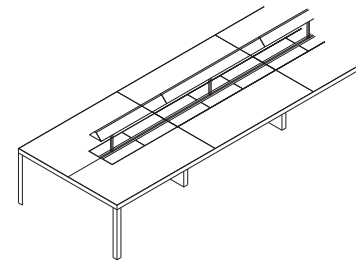

I A F S R 2
Braccio portamonitor/Monitor arm

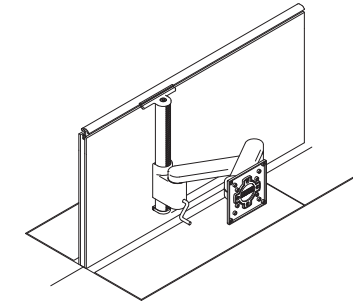

I A P V A
Contentitore pensile/Hanging bin

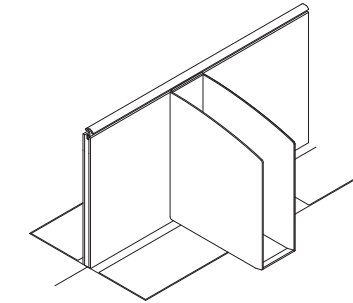

Q A P V
Vaschetta pensile/Hanging tray

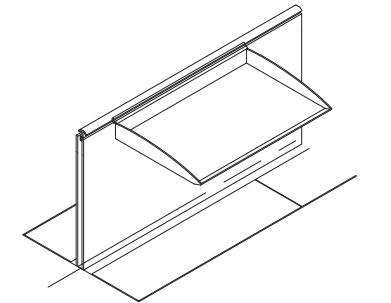

Y N 2 1 8 0 S 1 7
Y N 3 1 8 0 S 1 7
Y N 4 1 8 0 S 1 7
Schermo/Screen
Y N 2 1 8 0 L U
Y N 3 1 8 0 L U
Y N 4 1 8 0 L U
Luce sottopiano/Undertop light

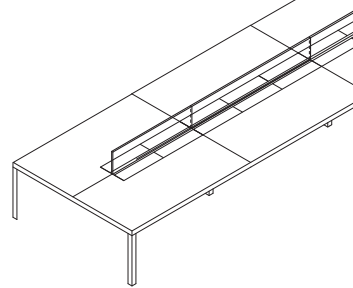

Y N 2 1 8 0 P 3 6
Y N 3 1 8 0 P 3 6
Y N 4 1 8 0 P 3 6
Schermo alto/High screen
Y N 2 1 8 0 L U
Y N 3 1 8 0 L U
Y N 4 1 8 0 L U
Luce sottopiano/Undertop light

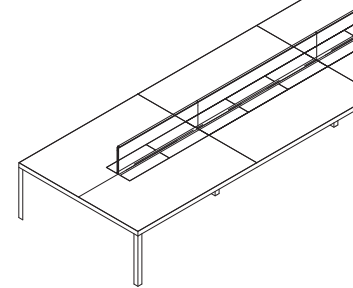

Y N 2 1 8 0 L T
Y N 3 1 8 0 L T
Y N 4 1 8 0 L T
Lampada/Lamp

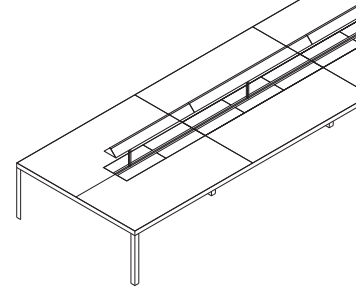

I A U N I 1 5 0 N S
Porta unità centrale/CPU holder

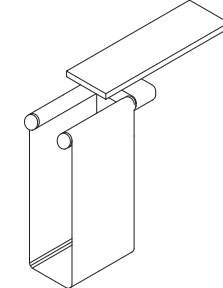

I A U N I 1 8 0 N S
Porta unità centrale/CPU holder

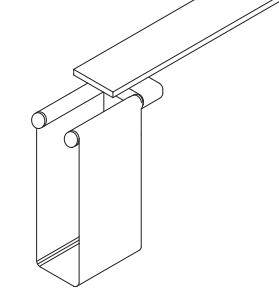

I A U N I 2 1 0 N S
Porta unità centrale/CPU holder

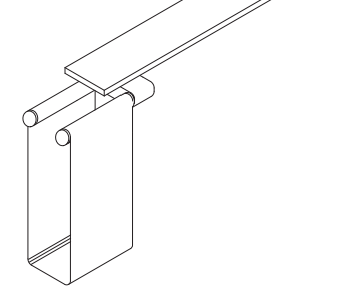

Y N 2 2 1 0 S 1 7
Y N 3 2 1 0 S 1 7
Y N 4 2 1 0 S 1 7
Schermo/Screen
Y N 2 2 1 0 L U
Y N 3 2 1 0 L U
Y N 4 2 1 0 L U
Luce sottopiano/Undertop light

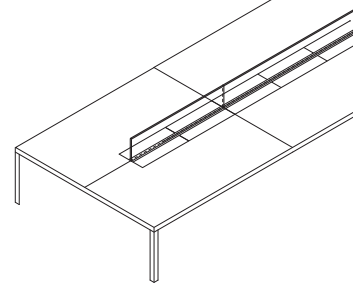

Y N 2 2 1 0 P 3 6
Y N 3 2 1 0 P 3 6
Y N 4 2 1 0 P 3 6
Schermo alto/High screen
Y N 2 2 1 0 L U
Y N 3 2 1 0 L U
Y N 4 2 1 0 L U
Luce sottopiano/Undertop light

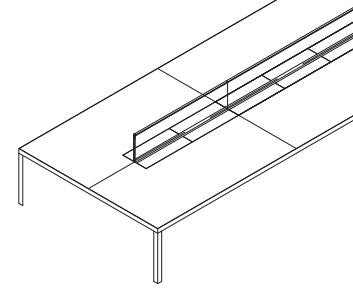

Y N 2 2 1 0 L T
Y N 3 2 1 0 L T
Y N 4 2 1 0 L T
Lampada/Lamp

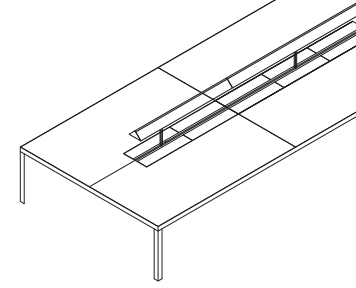

I A U N I 9 0 Y N S
Porta unità centrale/CPU holder

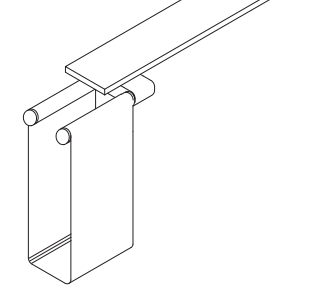

I A U N I 1 2 0 Y N S
Porta unità centrale/CPU holder

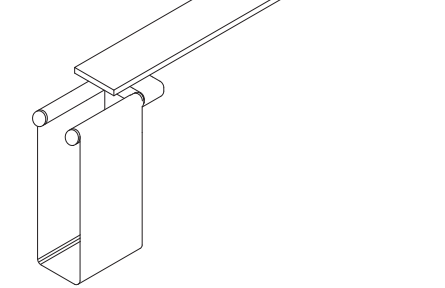

UNIFOR**Stabilimento e uffici**

22078 Turate (Como)
via Isonzo 1
tel. (02) 967 191
fax (02) 967 50859
(02) 967 50399
www.unifor.it
e-mail: unifor@unifor.it

Filiali italiane

20121 Milano
corso Matteotti 14
tel. (02) 7600 9024
fax (02) 7600 4765
e-mail: uniformilano@unifor.it

00173 Roma
via Tuscolana 1788
tel. (06) 721 0505-721 0479
fax (06) 721 1487
e-mail: uniforrroma@unifor.it

80121 Napoli
via D. Morelli 24
tel. (081) 764 4062-764 4172
fax (081) 764 3133
e-mail: unifornapoli@unifor.it

Agenzie italiane

70121 Bari
piazza Eroi del Mare 6
tel. (080) 5249373
fax (080) 5249484
e-mail: stecchi.system@tin.it

40128 Bologna
via del Lavoro 60
tel. (051) 631 1368
fax (051) 631 1370
e-mail: info@progetto-ufficio.com

39100 Bolzano
via Esperanto 3
tel. (0471) 050 505
fax (0471) 050 500
e-mail: info@artebobject.it

42040 Campegine (Reggio Emilia)
via Aldo Moro 8
tel. (0522) 906 154
fax (0522) 906 697
e-mail: prouf@tin.it

36030 Costabissara (Vicenza)
via Pasubio 17
tel. (0444) 557 894
fax (0444) 557 073
e-mail: fontanacontract@fontanasrl.net

35020 Padova Z.I.
Loc. Saonara
via Irpinia 56
tel. (049) 879 1870
fax (049) 879 1871
e-mail: info@ambienteufficio.it

90146 Palermo
via San Lorenzo, 155/161
tel. (091) 689 0738
fax (091) 751 0656
e-mail: mail@massimilianotroja.com

06100 Perugia
via Mario Angeloni 65
tel. (075) 500 2715
fax (075) 500 8984
e-mail: perugia@lorettiarredamenti.it

51100 Pistoia
via N. Machiavelli 25
tel. (0573) 975 458
fax (0573) 975 488
e-mail: info@logosforniture.it

33047 Remanzacco (Udine)
Strada di Oselin 78
tel. (0432) 649 232
fax (0432) 668 633
e-mail: info@multitema.it

24040 Stezzano (Bergamo)
via Circonvallazione Ovest 24
tel. (035) 454 0450
fax (035) 454 0460
e-mail: info@rova.it

61010 Tavullia (Pesaro)
via Selvagrossa 24/26
loc. Case bruciate
tel. (0721) 201366
fax (0721) 202483
e-mail: dellachiara@dellachiara.it

38100 Trento
via Dosso Dossi 4
tel. (0461) 828 900
fax (0461) 828 901
e-mail: info@habitat-ufficio.it

31100 Treviso
via Ponchielli 2
tel. (0422) 262 223
fax (0422) 262 386
e-mail: sagola@tin.it

37138 Verona
via Albere 47/A
tel. (045) 567 066
fax (045) 572 041
e-mail: centrufficioverona@tiscali.it

Filiali estere

Australia
Unifor Australia Pty Ltd
140 Bank Street
Pymont, N.S.W. 2009
tel. (02) 9552 9552
fax (02) 9552 9553
e-mail: sydney@uniforaust.com

Unifor Melbourne Office
450 Latrobe Street
Melbourne Victoria 3000
C/o Phoenix Lane
tel. (03) 9329 5900
fax (03) 9329 9766
e-mail: melbourne@uniforaust.com

France
Unifor France S.A.
6 rue des Saints Pères
75007 Paris
14 rue Pierre Nicolau
93582 Saint Ouen (Cedex)
tel. (01) 4012 7717
fax (01) 4010 0124
e-mail: unifor@unifor.fr

Great Britain
Ergonom Ltd.
Whittington House
19-30 Alfred Place
London WC1E 7EA
tel. (0207) 3232 325
fax (0207) 3232 032
e-mail: enquiry@ergonom.com

Hong Kong
Unifor Hong Kong Ltd.
19th Floor
Top Glory Tower
262 Gloucester Road
Hong Kong
tel. (852) 2836 9333
fax (852) 2836 9997
e-mail: unifor@unifor.com.hk

Singapore/Malaysia
Unifor Asia Pacific Pte Ltd
11 Keppel Road
01-01 RCL Centre
Singapore 089057
tel. (65) 6221 1822
fax (65) 6221 1833
e-mail: general@unifor-asia.com

U.S.A.
Unifor
149 Fifth Avenue
New York, NY 10010
tel. (212) 673 3434
fax (212) 673 7317
e-mail: unifor@uniforusa.com

Rappresentanze estere

Austria
Pflau
Am Gestade
A-1010 Wien
tel. (01) 535 4075
fax (01) 535 40759
e-mail: office@pflau.com

Bahrain
Pico international
Po. box 13990 Muharraq Bahrain
tel. 218 8998
tel. (02) 531 1350
fax 226 555
e-mail: picobah@batelco.com.bh

Belgium
SV Interior Projects NV/SA
Koningin Astridlaan 59
Avenue Reine Astrid
B-1780 Wemmel
tel. (02) 531 1350
fax (02) 531 1351
e-mail: info@sv.be

Canada
Italinteriors Contract
276 King Street West
Suite 30
Toronto , Ontario M5V 1J2
tel. (0416) 364 1011
fax (0416) 364 7978
e-mail: info@italinteriors.com

Chile
Muzard S.A.
Merced 26
Santiago
tel. (02) 639 1421
fax (02) 639 1958
e-mail: miguel@muzard.com

Croazia
Art Avantgarde
ilica 15
Zagreb HR
tel. (1) 48 12 900
fax (1) 48 17 217
e-mail: aag.dizain.centar@zg.hinet.hr

Czech Republic
Konsepti
Komunardu 32
170 00 Praha 7
tel. (0222) 326 928
fax (0222) 321 358
e-mail: studio@konsepti.cz

Denmark
Hans Due Design AS
Rungstedvej 16
DK-2970 Horsholm
tel. (0045) 4576 1516
fax (0045) 4576 1517
e-mail: hd@hansduedesign.dk

Dubai
Al Reyami Group
Po. box 14662 Dubai
tel. (4) 336 4666
fax (4) 336 6775
e-mail: rof@emirates.net.ae

Ofis Al Gurg OFD
Po. box 325 Dubai
tel. (4) 335 2499
fax (4) 336 5643
e-mail: info@ofisdubai.com

Germany
Uni.Projekt
Vertriebsgesellschaft mbH
Tulpenweg 4
93138 Lappersdorf
tel. (0941) 897 9082
fax (0941) 897 9085
e-mail: info@unifor.de

Showroom
Charlottenstr. 77
10117 Berlin
tel. (030) 8804 790
fax (030) 8804 7920
e-mail: vb.berlin@unifor.de

Greece
New plan Ltd.
2, Vas. Alexandrou St.
16121 Athens
tel. (01) 729 1091
fax (01) 723 9870
e-mail: newplan@otenet.gr

Holland
SV Interieur Groep
Terbregse Rechter
Rottekade 137
3055 XC Rotterdam
tel. (010) 211 2050
fax (010) 422 3495
e-mail: info@sv.nl

Showroom
Dorpsstraat 75
1182 JC Amstelveen
tel. (020) 347 2130
fax (020) 647 0095

Hungary
Sincord
Vahot u.6
H-1119 Budapest
tel. (01) 203 0320
fax (01) 203 0311
e-mail: sincord@sincord.hu

Ireland
Project Office
1 Exchange Street Upper
Temple Bar West
Dublin 8
tel. (01) 671 5700
fax (01) 671 5701
e-mail: unifor@projectoffice.ie

Israel
Midua Engineering & Systems
36, Ein-hai Str., Kfar Malal
P.O. Box 1234
Hod-Hasharon 45111
tel. (09) 744 2881
fax (09) 744 2880
e-mail: midua@shani.net

Japan
Shukoh Co. Ltd.
Nihon Seimei Kawasaki Building
1-1, Minami-machi
Kawasaki- ku, Kawasaki-shi
210-0015 Kanagawa
tel. (044) 210 5123
fax (044) 246 9861
e-mail: sec@shukoh.co.jp

Showroom
Tokyo Design Center 7th floor
5-25-19, Higashi-Gotanda
Shinagawa-ku, Tokyo 141-0022
tel. (03) 5798 2231
fax (03) 5498 2232

Messico
Esencial
Polanco Goldsmith 60
11560 Mexico City
tel. (55) 5282 2034
e-mail: afermandez@esencial.com.mx

New Zealand
Cite Ltd.
18 Normandy Road
Mt Eden
Auckland 1001
tel. (09) 623 9233
fax. (09) 623 0233
e-mail: katrina@citeltl.co.nz

Norway
Robert Tandberg
Postboks 538 Sentrum
N-0105 Oslo
Besøksadresse:
Dronningensgate 10-14
N-0152 Oslo
tel. (0047) 22473020
fax (0047) 22473021
e-mail: rune@roberttandberg.no

Portugal
Helder Gonçalves
Largo do C8 145
4595-298 Penamaior
tel. (255) 866 001
fax (255) 866 002
e-mail: helder@spring.mail.pt

Russia
000 Artica
Staraya Basmannaya 15/2
Moscow
tel. (095) 261 3260
fax (095) 261 3260
e-mail: sosidach@unifor.info

Transphere
Timura Frunze Ulitza
c/o Artplay centre
Moscow
tel. (095) 543 9707
fax (095) 543 9704
e-mail: info@transphere.ru

Slovenija
I D
Slovenska c.9
1000 Ljubljana
tel. (061) 426 9030
fax (061) 426 9032
e-mail: info@id-online.net

Spain
Unifurniture, S.L.
c/. Casp., 46 Desp. 2º 1º A
08010 Barcelona
tel. (093) 412 4635
fax (093) 412 4831
e-mail: info@unifurniture.net

Switzerland
Unitrend
Riedstrasse 1
CH-6343 Rotkreuz
tel. (041) 790 5454
fax (041) 790 5575
e-mail: info@unifor.ch

Testi: Livio Salvadori
Foto: Mario Carrieri

Fotolito: Pluscolor
Stampa: Grafiche Mariano
Finito di stampare: Febbraio 2008

