

CRONO

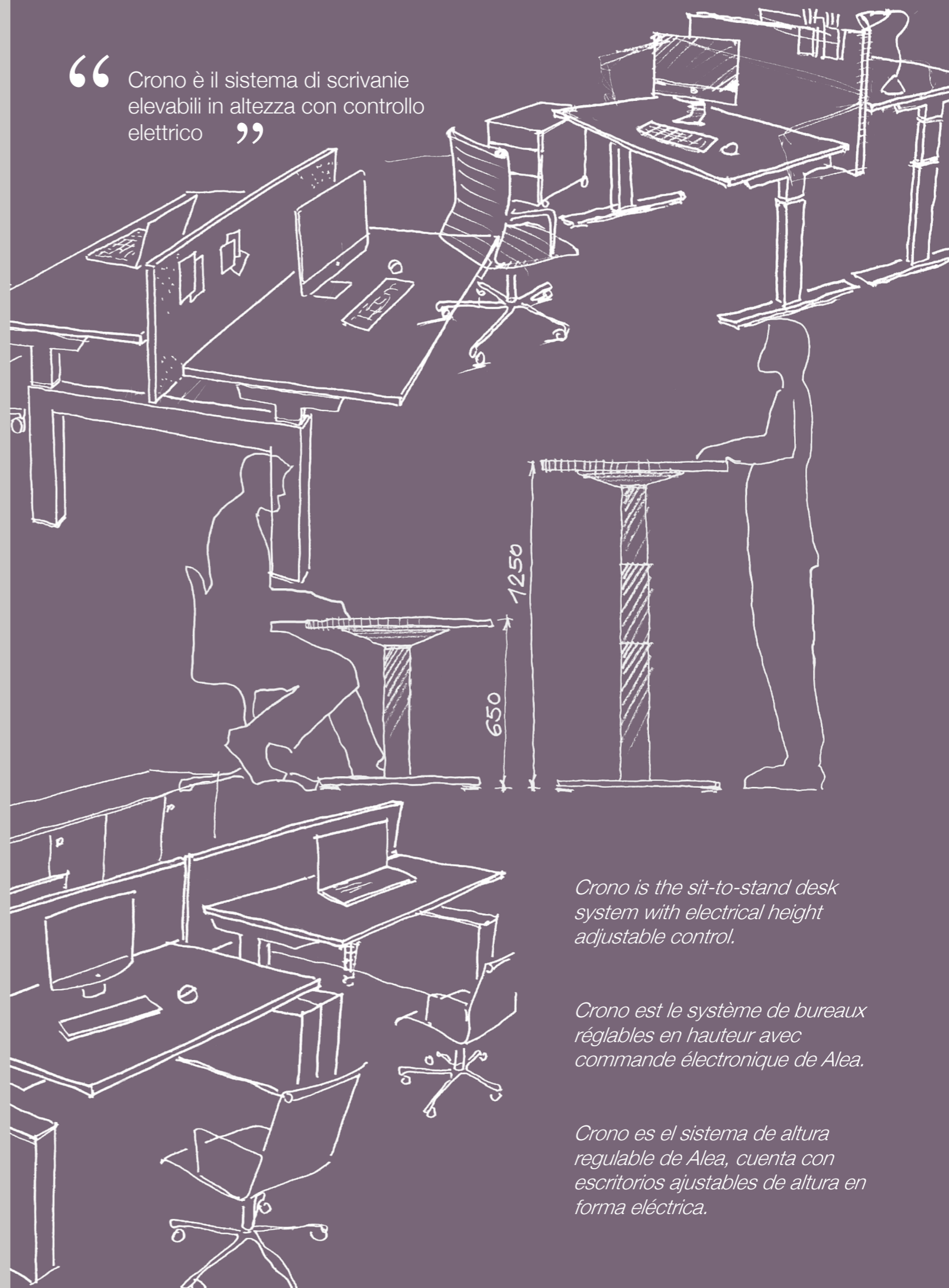

“ Crono è il sistema di scrivanie elevabili in altezza con controllo elettrico ”



Crono is the sit-to-stand desk system with electrical height adjustable control.

Crono est le système de bureaux réglables en hauteur avec commande électronique de Alea.

Crono es el sistema de altura regulable de Alea, cuenta con escritorios ajustables de altura en forma eléctrica.



Crono è un sistema di scrivanie e postazioni multiple regolabili elettricamente in altezza. Il sistema è stato studiato e progettato per rispondere alla necessità di creare postazioni di lavoro ergonomiche, capaci di maggiore attenzione alla salute e al benessere dell'utilizzatore.

Crono is an electrical height-adjustable system fitting freestanding desks and benches. The system has been designed to respond to the demand of ergonomic workstations oriented to the health and well-being of the user.

Crono est un système de bureaux et de bench réglables en hauteur avec commande électronique. Le système a été étudié et conçu pour répondre à la nécessité de créer des postes de travail ergonomiques et de prêter plus d'attention à la santé et au bien-être de l'utilisateur.

Crono es un sistema eléctrico de altura ajustable que se adapta a escritorios y bancos independientes. El sistema ha sido diseñado para responder a la demanda de estaciones de trabajo ergonómicas orientadas a la salud y el bienestar del usuario.





La scrivania può essere dotata di accessori per la gestione del cablaggio, quali top access, e vertebre in materiale plastico.

The desk can be equipped with wiring accessories such as top access and plastic vertical cable ducts to handle all cable and power outlet requirements.

Le bureau peut être équipé d'accessoires pour la gestion du câblage tels que top access et vertèbres remontée de câbles en plastique.

El escritorio puede equiparse con accesorios de cableado tales como top access y vértebras de policarbonato translúcido.







La struttura si compone di montanti in alluminio collegati a piedi in acciaio ed è disponibile con sviluppo telescopico a 1 o 2 stadi. Il piano è realizzato in nobilitato melaminico di spessore pari a 30 mm e bordato in ABS da 2 mm. Le gambe sono collegate tra loro tramite una trave metallica.

The structure is made of aluminium uprights joined to steel feet and is available with telescopic extension with 1 or 2 steps. The desktop is made of Italian melamine, 30 mm thick, with 2 mm ABS edge. The legs are connected to each other through a metal beam.

La structure est composée de montants en aluminium assemblés à des pieds en acier et est disponible avec une extension télescopique à 1 ou 2 étapes. Le plan de travail est réalisé en mélaminé de 30 mm d'épaisseur avec chant en ABS de 2 mm. Les jambes sont reliées entre elles par une poutre métallique.

La estructura está hecha de montantes de aluminio unidos a pies de acero y está disponible con extensión telescópica con 1 o 2 pasos. El sobre está hecho de melamina de 30 mm de grosor con borde de ABS de 2 mm. Las patas están conectadas entre sí a través de un estructura de metal.

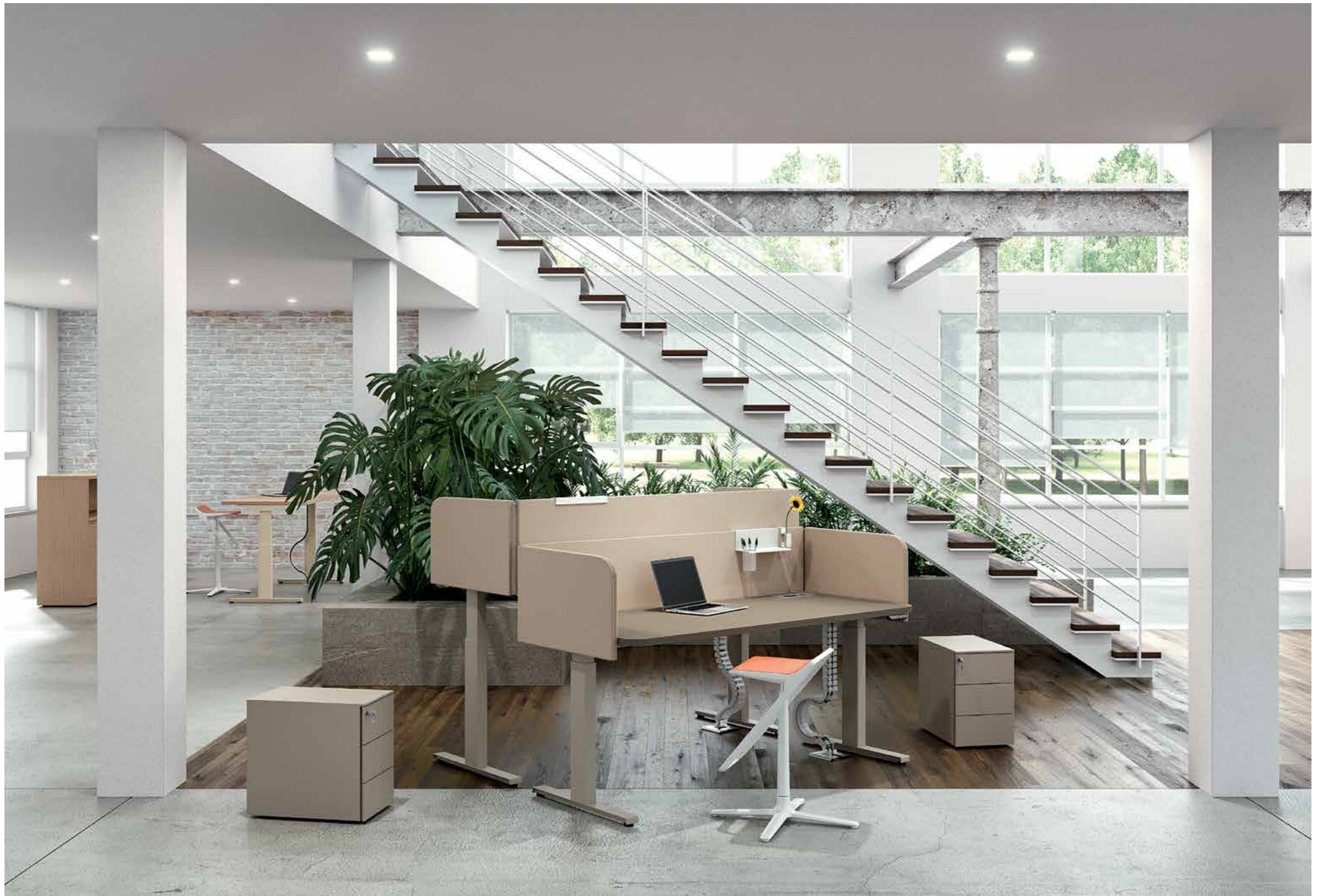

Alla scrivania può essere applicato uno screen ergonomico che copre fronte e lati, rivestito in tessuto puntaspilli e integrabile con accessori in metallo.



An ergonomic and pinnable screen, covering the front and sides of the desk, can be supplied. It is upholstered in fabric with the possibility of hanging metal accessories.

Un écran ergonomique couvrant l'avant et les côtés du plan de travail peut être appliqué au bureau, recouvert de tissu punaisable, il peut être équipé d'accessoires en métal.

Una pantalla ergonómica y pinchable, que cubre la parte frontal y los laterales del escritorio, se puede aplicar al escritorio. Está tapizada en tela y se puede integrar con accesorios metálicos.







Oltre alla scrivania singola, Crono offre la possibilità di comporre delle postazioni multiple. In questo caso l'appoggio a terra è garantito da colonne prive di piede, unite tra loro da un traverso.



In addition to the stand alone desk, Crono structure works as well for benches. In this case the structure is a simple column without a foot, joined with a structural beam.

En plus du bureau, Crono offre la possibilité de composer des postes de travail multiples. Dans ce cas le support au sol est garanti par des colonnes sans pied, reliées entre elles par une traverse.

Además del escritorio individual, la estructura Crono también funciona para bancos. En este caso, el soporte de tierra está garantizado por columnas sin pie, unidas por una viga estructural.







The elevation is controlled by a handswitch positioned underneath the top, also available in the programmable version with the possibility to store up to 4 positions in height.

L'élévation est contrôlée par un tableau fixé sous le plan de travail, également disponible dans la version programmable donnant la possibilité de mémoriser jusqu'à 4 hauteurs différentes.

L'elevazione è regolata da una pulsantiera che viene fissata sotto il piano, disponibile anche nella versione programmabile con possibilità di memorizzare fino a 4 posizioni in altezza.



La elevación está controlada por un interruptor de mano ubicado debajo del sobre, también disponible en la versión programable con la posibilidad de almacenar hasta 4 posiciones de altura.

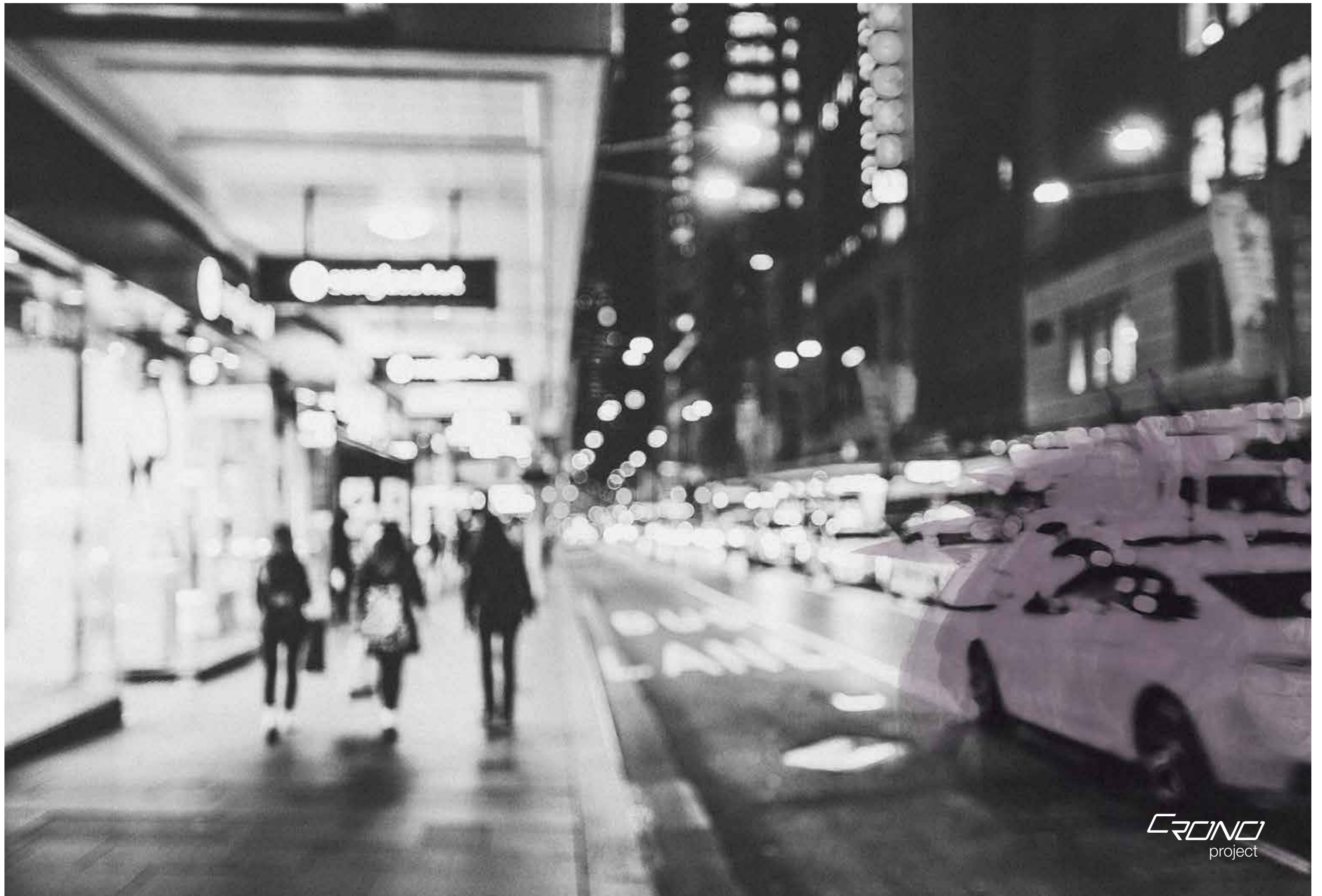



La struttura di Crono può essere integrata a contenitori laterali e pannelli frontali a creare ambiti di lavoro con adeguata privacy per gli operatori.



Crono structure can be integrated with adjacent storage units and frontal panels to create cubical units with high privacy standards and improved aesthetic.

La structure de Crono peut être intégrée avec des meubles porteurs latéraux et des écrans frontaux afin de créer une île de travail offrant une intimité maximale à son utilisateur.

La estructura Crono se puede integrar a contenedores laterales y paneles frontales personalizados para crear unidades cúbicas con altos estándares de privacidad.













I piani scrivania sono disponibili anche con angoli stondati per abbinarsi alla forma ergonomica degli screen.

Desktops are also available with rounded corners to match the ergonomic shape of the screens.

Les plans de travail sont également disponibles avec coins arrondis pour répondre à la forme ergonomique des écrans.

Los escritorios también están disponibles con esquinas redondeadas para que coincidan con la forma ergonómica de las pantallas.









The solid legs, besides an improved aesthetics, give the possibility of accommodating the cables inside them. The folded structure can be easily inspected by means of a removable panel.

Les piètements peuvent être insérés dans des caissons vides, dit murets, qui, en plus d'une variable esthétique, donnent la possibilité de stocker le câblage et réaliser l'électrification des plans de travail d'une façon propre et efficace. La structure, réalisée en folding de mélaminé, peut être aisément inspectée grâce à un panneau amovible.

Las patas sólidas, además de una estética diferente, brindan la posibilidad de ocultar y pasar los cables dentro de ellas. La estructura, hecha de forma plegada, se puede inspeccionar fácilmente por medio de un panel extraíble

Le gambe possono essere inserite in scocche, dette muretti, i quali, oltre ad una variabile estetica, danno la possibilità di elettrificare i piani lavoro in quanto cavi al loro interno. La struttura, realizzata in folding, è ispezionabile grazie ad un pannello amovibile.







In the multiple workstations Crono features fabric pinnable frontal screens fixed to the structure.

Pour les postes multiples type bench on utilise des écrans frontaux en tissu punaisable fixés à la structure.

En las múltiples estaciones de trabajo, Crono presenta pantallas frontales pinchables de tela fijadas a la estructura.

Nelle postazioni multiple vengono utilizzati screen frontali in tessuto puntaspilli fissati alla struttura.





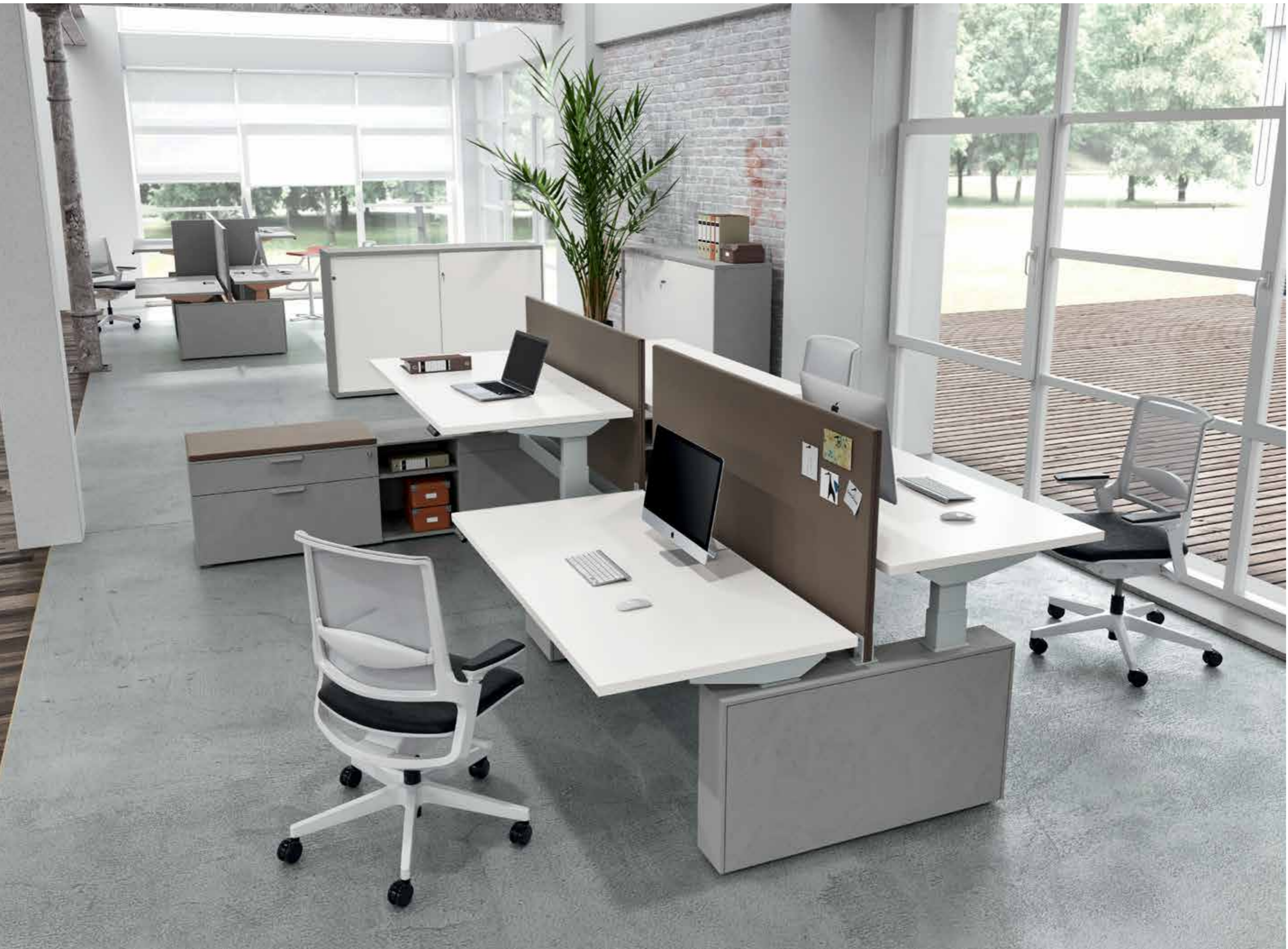

I contenitori laterali prevedono sezioni a giorno e con cassetti classificatori. Possono essere completate da cuscini rivestiti in tessuto abbinato agli screen.



The side storage units are provided with open shelving and filing drawer sections. They can be completed with fabric-coated cushions combined with the screens.

Les meubles porteurs latéraux se composent de modules casiers ouverts pour le classement et des rangements à tiroirs pour dossiers suspendus. Ils peuvent être équipés sur le dessus avec des coussins en tissu assortis à celui des écrans.

Los contenedores laterales cuentan con un compartimiento abierto y cajones archivadores. Se pueden completar con cojines recubiertos de tela combinada con las pantallas.





Crono offers different finishes for the top and for the structure allowing many colour combinations.

Crono offre de nombreuses finitions différentes pour le plan de travail et pour sa structure, ce qui donne une grande variété de combinaisons possibles.

Crono ofrece diferentes acabados para el sobre y para la estructura que permiten muchas combinaciones de colores.

Crono offre numerose finiture per il piano e per la struttura che si possono comporre con molteplici combinazioni di colore.

Estensione della struttura | *structure extention* | *extension de la structure* | *extensión de la estructura*

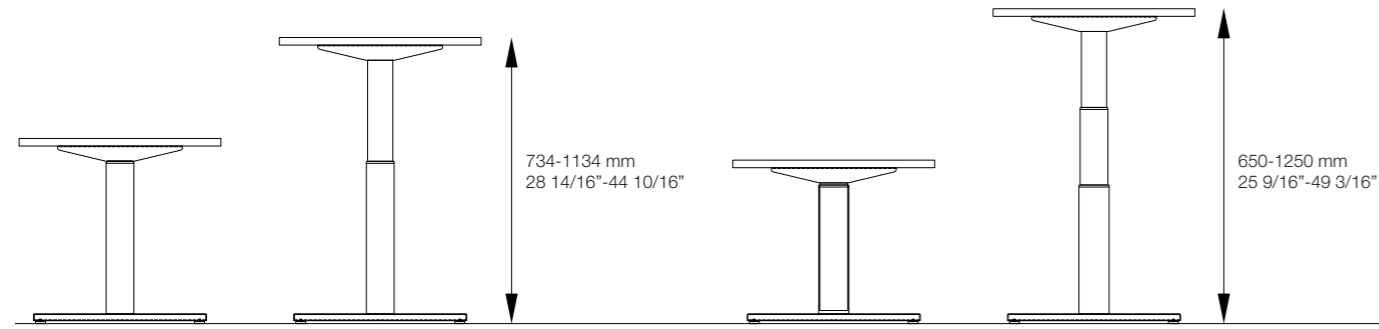

1 step
1 step
1 niveau
1 step

2 step
2 steps
2 niveaux
2 step

Tipologia di piede | *foot type* | *type de pied* | *tipo de pie*

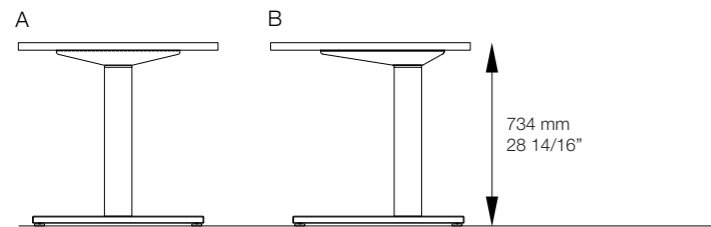

A) Piede dritto simmetrico, B) Piede dritto asimmetrico
A) Straight symmetrical foot, B) Straight asymmetrical foot
A) Pied droit symétrique, B) Pied droit asymétrique
A) Pie recto simétrico, B) Pie recto asimétrico

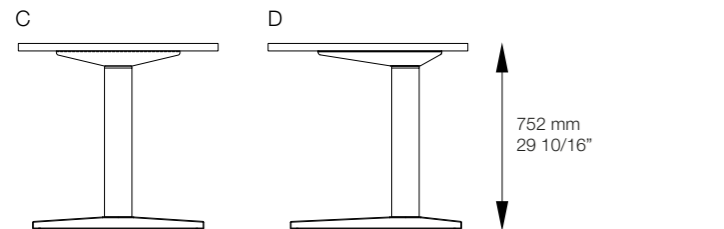

C) Piede sagomato simmetrico, D) Piede sagomato asimmetrico
C) Shaped symmetrical foot, D) Shaped asymmetrical foot
C) Pied courbe symétrique, D) Pied courbe asymétrique
C) Pie curvo simétrico, D) Pie curvo asimétrico

Per la versione con piede sagomato le altezze minima e massima sopra riportate, sono aumentate di 18 mm, a causa della forma del piede.
On the version with shaped feet, the minimum and maximum height are increased by 18 mm (11/16") due to the shape of the feet.
Pour la version avec le pied courbe, les hauteurs minimales et maximales mentionnées ci-dessus, sont augmentées de 18 mm, en raison de la forme du pied.
En la versión con pie curvo, la altura mínima y máxima incrementa de 18 mm debido a la forma de los pies.

Struttura freestanding | *freestanding structure* | *structure autoportante* | *estructura independiente*

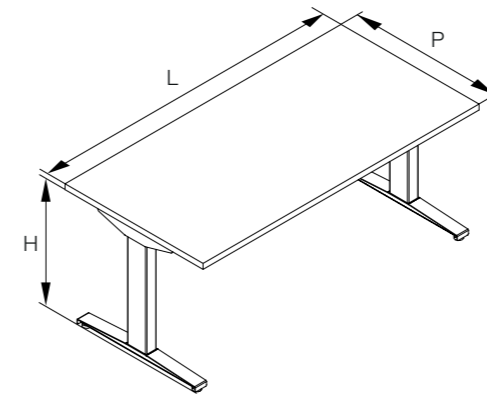

H 734 - 1134 mm 8 14/16"x 44 10/16" 650 - 1250 mm 25 9/16"x 49 3/16"				
	L 140 55 2/16"	L 160 63"	L 180 70 14/16"	L 200 78 12/16"
P 80 31 8/16"	•	•	•	•
P 90 35 7/16"			•	•

Bench | *bench* | *bench* | *bench*

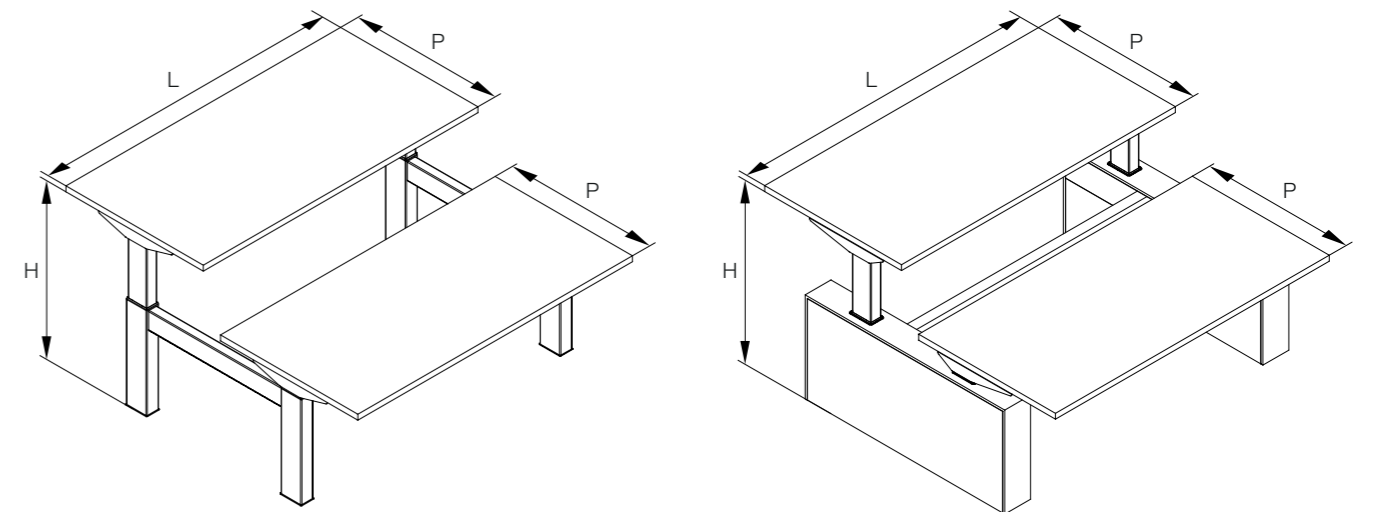

H 734 - 1134 mm 8 14/16"x 44 10/16" 650 - 1250 mm 25 9/16"x 49 3/16"				
	L 140 55 2/16"	L 160 63"	L 180 70 14/16"	L 200 78 12/16"
P 80 31 8/16"	•	•	•	•

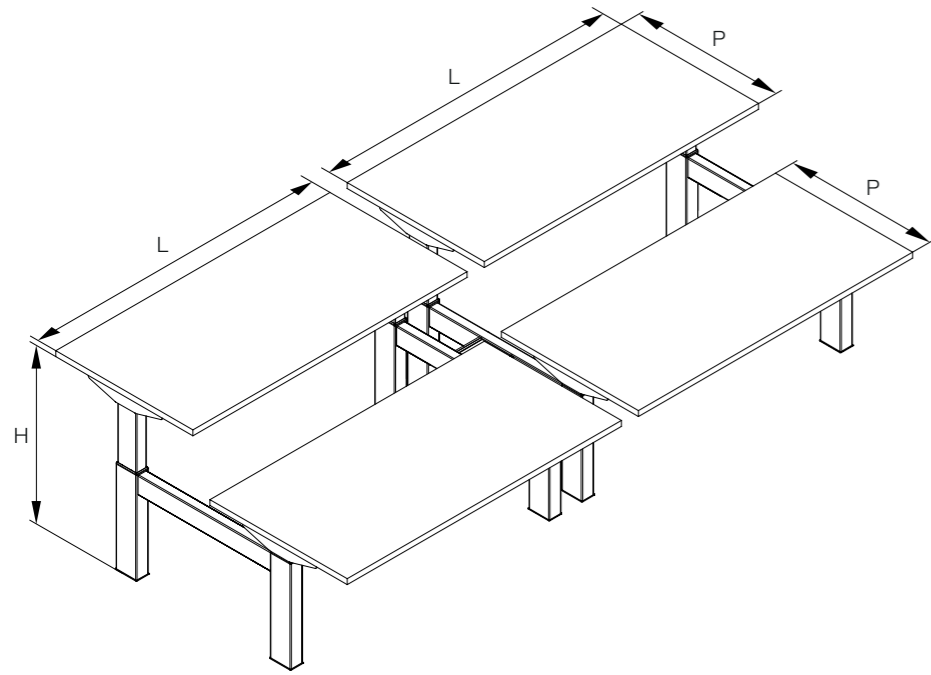

Pulsantiera | *handswitch* | *tableau* | *mando de control*



Pulsantiera semplice
Basic handswitch
Tableau simple
Mando de control simple





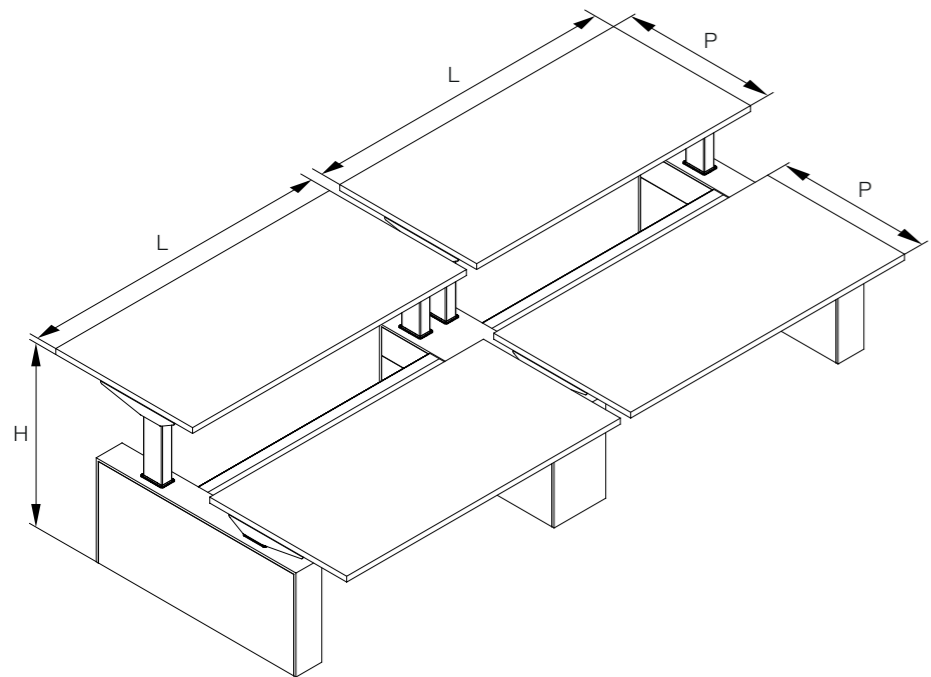





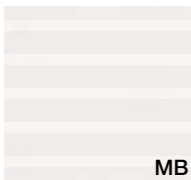



Pulsantiera con 4 memorie
Handswitch with 4 memories
Tableau avec 4 mémoires
Mando de control con 4 memorias

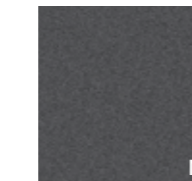



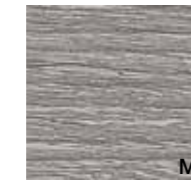

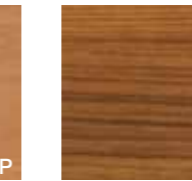

H 734 - 1134 mm 8 14/16" x 44 10/16" 650 - 1250 mm 25 9/16" x 49 3/16"				
	L 140 55 2/16"	L 160 63"	L 180 70 14/16"	L 200 78 12/16"
P 80 31 8/16"	•	•	•	•

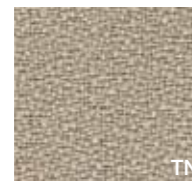
Melaminico Italian melamine Melaminé Melaminico



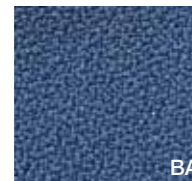



 Bianco rigato Rippled effect white Blanc avec rayures en sérigraphie Blanco rayado	 Grigio rigato Rippled effect grey Gris avec rayures en sérigraphie Gris rayado	 Nichel Nickel Nickel Niquel	 Cacao Cocoa Cacao Cacao		
 Bianco White Blanc Blanco	 Talco Talco Talco Talco	 Noisette Noisette Noisette Noisette	 Ardesia Ardesia Talco Pizarra	 Nero Black Noir Negro	
 Rovere chiaro Light oak Chêne clair Roble claro	 Rovere americano American oak Chêne américain Roble americano	 Rovere grigio Grey oak Chêne gris Roble gris	 Rovere moro Dark oak Chêne foncé Roble oscuro	 Noce Chiaro Walnut Noyer Nogal	 Noce Canaletto Canaletto Walnut Noyer Canaletto Nogal Canaletto
Piano Top Plateau Sobre	Modesty panel Modesty panel Voile de fond Faldón	Screen Screen Écran Panel	Muretto Solid leg Niveau Costado		

Tessuto Fabric Tissu Tejido









 Perla Pearl grey Gris perle Gris perla	 Crema Creme Crème Crema	 Tortora Turtledove Tourterelle Tortola	 Grigio Grey Gris Gris	 Arancione Orange Orange Naranja	 Rosso Red Rouge Rojo
 Blu Blue Bleu Azul	 Blu avio Sky blue Bleu clair Azul "Avio"	 Verde acqua Aqua green Vert d'eau Verde agua	Screen Screen Écran Panel		

• Le finiture contenute nel presente catalogo sono puramente indicative e non sono di riferimento per le forniture del prodotto.
• Due to the printing process, finishes shown in this catalogue are for illustration only. The finish on the final item may differ slightly from the printed illustration.

Goffrato Embossed Gaufré Gofrado

 Goffrato Moka Embossed Mocha Gaufré Moka Gofrado Cafe	 Goffrato Indaco Embossed Indigo Gaufré Indigo Gofrado Azul Indigo	 Goffrato Rubino Embossed Ruby Gaufré Rubis Gofrado Rubi	 Goffrato Cedro Embossed lime green Gaufré vert Cédrot Gofrado verde Cedro	 Goffrato Argento Embossed Silver Gaufré Argent Gofrado Plata	 Goffrato bianco Embossed white Gaufré blanc Gofrado blanco
 Goffrato nero Embossed black Gaufré noir Lacado negro	 Goffrato rosso "F" Embossed red "F" Gaufré rouge "F" Lacado rojo "F"	 Goffrato arancione Embossed orange Gaufré indigo Lacado naranja	 Goffrato grigio scuro Embossed grey Gaufré gris Lacado gris	 Goffrato azzurro Embossed blue Gaufré bleu Lacado azul	 Goffrato verde Embossed green Gaufré vert Lacado verde
 Ardesia Ardesia Ardesia Pizarra	 Noisette Noisette Noisette Noisette	Screen Screen Écran Panel			

Metacrilato Metacrylate Méthacrylate Metacrilato

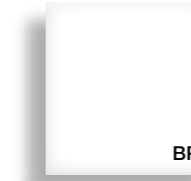
 Trasparente Transparent Transparent Transparente	 Rosso trasparente Red transparent Rouge transparent Rojo transparente	 Blu trasparente Blue transparent Bleu transparent Azul transparente	 Bianco satinato Satin-finish white Blanc satiné Blanco satinado	 Arancione satinato Satin-finish orange Orange satiné Naranja satinado	 Blu satinato Satin-finish blue Bleu satiné Azul satinado
 Verde satinato Satin-finish green Vert satiné Verde satinado	 Grigio fumè satinato Satin-finish smoky grey Gris satiné Gris satinado	 Bianco opalino Opaline white Blanc opalin Blanco opaco	Screen Screen Écran Panel		

• Les finitions contenues dans ce catalogue ne sont pas contractuelles - les photos ne pouvant rendre la parfaite réalité.
• Los acabados contenidos en este catálogo son puramente indicativos y no son de referencia para los suministros del producto.

Epossidico Epoxy Epoxyde Epoxídico



Bianco
White
Blanc
Blanco



Talco
Talco
Talco
Talco



Grigio
Grey
Gris
Gris



Sabbia
Cream
Sable
Arena



Noisette
Noisette
Noisette
Noisette



Ardesia
Ardesia
Ardesia
Pizarra



Oro
Gold
Or
Oro



Rame
Copper
Cuivre
Cobre



Bronzo
Bronze
Bronze
Bronce



Nero
Black
Noir
Negro

Gamba
Leg
Pied
Pata

• **Le finiture contenute nel presente catalogo sono puramente indicative e non sono di riferimento per le forniture del prodotto.**
 • Due to the printing process, finishes shown in this catalogue are for illustration only. The finish on the final item may differ slightly from the printed illustration.
 • Les finitions contenues dans ce catalogue ne sont pas contractuelles - les photos ne pouvant rendre la parfaite réalité.
 • Los acabados contenidos en este catálogo son puramente indicativos y no son de referencia para los suministros del producto.

concept & graphic design
Alea marketing + communication

design
Filippon & Mirto Antonel

art direction
Mirto Antonel

CE/CABH/AA



GLOBAL HEADQUARTERS AND SHOWROOM : Via Col de Rust, 19 - 33070 Sarone (PN) - Italia : Tel ++39 0434 777 333
www.aleaoffice.com - email: info@aleaoffice.com

NORTH AMERICAN HEADQUARTERS : Midtown 2, 3449 NE 1st Avenue L-32, Miami, FL 33137 - USA : Tel ++1 305 470 1200
www.alea-usa.com - email: info@alea-usa.com

NEW YORK SHOWROOM : New York Design Center, 200 Lexington Ave Suite #1509, New York, NY 10016 – USA

ALEA UK OFFICE AND SHOWROOM : 50-54 Clerkenwell Road, London EC1M 5PS : www.aleaoffice.co.uk - email: info@aleaoffice.com