

企业概况
profil d'entreprise
company profile
企业概况
Firmenprofil
Företagsprofil
profil tyrtke
شركة
oemutatkozás

компания
perfil de la compañía

профіль
profilo aziendale

بيانات
profil da
profil d'ent

company profile

alea

CMC, the mother company, is established specializing in home and office furnishings.

*Si costituisce CMC, azienda madre specializzata in arredamento per casa e ufficio.
Fondation de CMC, société mère spécialisée dans le mobilier pour la maison et le bureau.
Se constituye CMC, empresa matriz especializada en mobiliario para la casa y la oficina.*

1973



1992



Teatro becomes the first Alea product to achieve international success.

*La collezione Teatro diventa il primo prodotto Alea di successo internazionale.
Le produit Teatro devient le premier produit Alea au succès international.
El producto Teatro se convierte en el primer producto Alea de éxito internacional.*

1998



The Oscar column collection enables Alea to compete for the most prestigious tenders.

*Il sistema a colonna Oscar consente ad Alea di competere nei tender più prestigiosi.
Le système à colonnes Oscar permet à Alea de concurrencer ses adversaires lors de la présentation des offres les plus prestigieuses.
El sistema de columna Oscar permite competir a Alea en las más prestigiosas licitaciones.*

1993



The Alea brand is created for the office division.

*Nasce il marchio Alea ad identificare la sola divisione ufficio.
Création de la marque Alea identifiant uniquement la division mobilier de bureau.
Nace la marca Alea, que incluye solamente la sección de mobiliario para oficina.*

The Zefiro collection is included in the 2003 ADI INDEX, and nominated for the Compasso d'Oro prize in 2004.

*Zefiro viene inserito nel ADI INDEX 2003, selezione Compasso d'Oro 2004.
Zefiro fait son apparition dans ADI INDEX 2003, sélection "Compasso d'Oro 2004".
Zefiro se incorpora en el ADI INDEX 2003, selección Compasso d'Oro 2004.*

2002



Alea USA is established in Miami to directly meet the requirements of the North American market.

*Nasce Alea USA a Miami per supportare direttamente il mercato nord americano.
Naissance d'Alea USA à Miami pour fournir un support direct au marché de l'Amérique du Nord.
Nace Alea USA en Miami con la intención de apoyar directamente al mercado norteamericano.*

2007



Regional Government of Friuli-Venezia Giulia awards the Ecopack packaging line for its groundbreaking technology with low environmental impact.

*La regione FVG premia la linea imballo Ecopack per l'innovazione tecnologica in materia di impatto ambientale.
La Région FVG remet un prix à la ligne d'emballage Ecopack pour son innovation technologique en matière d'impact environnemental.
La Región FVG premia la línea de embalaje Ecopack por su innovación tecnológica en materia de impacto ambiental.*

2003



2008



Bayer HealthCare's East Coast U.S. Headquarters project gets the 2013 Impact Award.

*Il progetto BAYER-New Jersey viene premiato con l'Impact Award 2013.
Le projet de Bayer HealthCare East Coast U.S. Headquarters remporte le prix en 2013 Impact Award.
El proyecto Bayer HealthCare's East Coast U.S. Headquarters lleva el premio en 2013 Impact Award*

2015



ADNOC project in Abu Dhabi.
*Progetto ADNOC Abu Dhabi.
Projet ADNOC Abu Dhabi.
Proyecto ADNOC Abu Dhabi.*

2013



A new office headquarters is opened in Sarone.
*Nuova sede direzionale a Sarone.
Implantation du nouveau siège social à Sarone.
Nueva sede central en Sarone.*



Mission and philosophy

Alea, established in 1973, has become a leading manufacturer of office furniture on the international scene due to its specialization. Alea offers a wide range of high quality products from executive and managerial collections to stylish operating systems. Our mission is helping people to operate in an attractive and efficient working environment. Alea is capable of providing tailor made solutions to meet specific customer requirements and needs.

Fondata nel 1973, Alea è diventata una delle aziende specializzate nell'arredamento per ufficio maggiormente attive sul mercato internazionale. La nostra missione è quella di arredare spazi lavorativi con soluzioni stimolanti e razionali. Alea propone una ampia gamma di prodotti di alta qualità per gli ambienti direzionali ed operativi, caratterizzati da una attenta ricerca di materiali e design innovativi. Oltre ai prodotti di serie, per assecondare le specifiche richieste della nostra clientela, possiamo offrire soluzioni personalizzate.

Alea est une Société privée italienne née en 1973 spécialisée dans la production de mobilier de bureau. Alea est devenue aujourd'hui une signature reconnue dans le monde entier. Alea propose une vaste gamme de produits d'excellente qualité. L'offre produits est large et couvre pratiquement toutes les exigences de l'aménagement du bureau. Notre but est d'offrir à nos clients un domaine ou travailler, qui soit agréable, attrayant et efficace. Alea est spécialisée aussi dans la production de solutions sur mesure pour répondre aux exigences et besoins spécifiques des clients. Cela représente à ce jour notre "core business".

Alea, es una empresa italiana fundada en 1973, es líder en la producción de mobiliario de oficina a nivel internacional por su especialización y la innovación incesante. Alea ofrece una amplia gama de productos de alta calidad a partir de las colecciones ejecutivas hasta los sistemas operativos. La misión de Alea es ayudar a mejorar la productividad de sus clientes pensando y realizando ambientes de trabajo atractivos y funcionales. Alea puede ofrecer un producto personalizado para así satisfacer las exigencias de todos los clientes.



Location and production organization

Alea corporate headquarters and manufacturing facilities are located 60 Kms North of Venice, in North Eastern Italy, one of the most productive and innovative manufacturing districts in Europe. This location allows Alea to respond quickly to the international market requests. The manufacturing process is inspired to the “just in time” concept and it is coordinated in real time with a network of local specialized suppliers, to guarantee prompt deliveries. All our products are Made in Italy.



Lo stabilimento produttivo è situato in uno dei piu' importanti distretti industriali europei, che concorre a fornire risposte rapide e professionali alle sollecitazioni dei mercati internazionali. La organizzazione produttiva si ispira al principio del 'just in time' e si fonda sulla cooperazione con un network di aziende specializzate coordinate da Alea in tempo reale per consentire una rapida evasione delle commesse. I prodotti Alea sono 100% Made in Italy.

Alea se trouve à 60 kms au nord de Venise, dans le Nord-Est de l'Italie, l'une des zones les plus dynamiques et industrialisées d' Europe, nous employons 80 effectifs, sur 15.000 m2. L'usine se trouve au milieu d'une région très importante de production de meubles. Cet emplacement permet à Alea de répondre rapidement à la demande des marchés avec une flexibilité d'adaptation unique aux demandes spécifiques du marché. L'organisation de la production est gérée par le principe "just in time" avec un réseau de fournisseurs spécialisés, coordonnés en temps réel, afin de garantir de promptes livraisons. Tous nos produits sont Made in Italy.

Alea se encuentra a 60 kilómetros al norte de Venecia, en el noreste de Italia, una de las zonas más dinámicas e industrializadas de Europa. La fábrica está situada en el centro de un distrito muy importante en la producción de muebles. Esta ubicación permite ALEA responder rápidamente a las rigurosas demandas de los mercados internacionales. ALEA trabaja siguiendo la lógica productiva del "just in time" y coordina un grupo de proveedores que le permiten satisfacer rápidamente a todos los requisitos, también a las más articuladas exigencias de los clientes. Nuestros productos son Made in Italy.





Market distribution and sales information

Alea has about 1,000 highly qualified dealers in more than 90 countries. Main Export destinations : France, U.S.A., Russia, U.K. , Middle East, Latin America. In order to provide a better service worldwide,Alea has opened three branches of its own in Miami (USA), Panama and Singapore. Exports represent about 95 % of total sales volume.

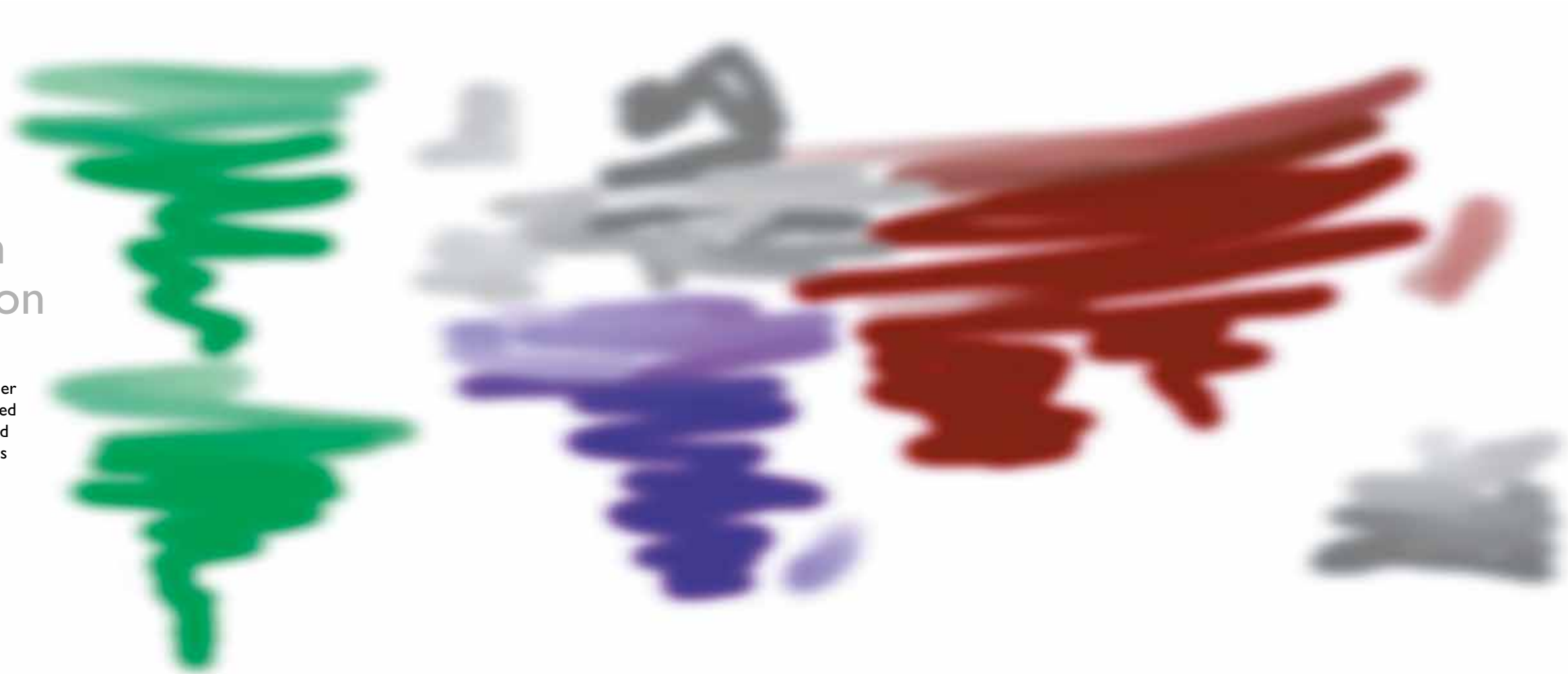

Alea conta su più di 1.000 distributori altamente specializzati operanti in circa 90 paesi di tutto il mondo. Le esportazioni coprono circa il 95% del fatturato globale. Le aree di destinazione dei prodotti Alea vanno dalla Francia, agli Stati Uniti, dalla Russia alla Gran Bretagna, dal Medio Oriente all'America Latina. Gli Stati Uniti – uno dei mercati maggiormente produttivi – vengono seguiti dalla sede di Alea USA situata a Miami (Florida).

Alea possède environ 1000 distributeurs hautement qualifiés dans plus de 90 pays du monde. Principales destinations d'exportation: USA, CE, Moyen-Orient, Ameriques. Afin de fournir un meilleur service dans le monde entier, Alea a ouvert trois succursales propres à Miami (USA), Panama et Singapour. L'exportation représente 95% du volume des ventes.

Alea colabora con 1.000 distribuidores altamente calificados en más de 90 países. Principales destinos de exportación : EE.UU, CE, Oriente Medio y América Latina. Con el fin de ofrecer un mejor servicio en todo el mundo, Alea ha abierto tres sucursales en Miami (EE.UU), Panamá y Singapur. Las exportaciones representan alrededor del 95% del volumen de ventas (año 2013)

Design and innovation

Alea is focused on design-oriented collections, particularly appreciated by the A & D community. Aiming at quality and innovation, Alea's collections are characterized by their style and unique technical features. Alea's bestseller Zefiro has been chosen as a product of innovative design and has been shortlisted for the prestigious ADI Design awards (selection for Golden Compass).



Alea si è sempre caratterizzata per prodotti di alto profilo tecnico e dallo stile innovativo: questa attitudine è molto apprezzata da architetti e designer internazionali. Negli arredi di Alea la qualità dei materiali si combina con uno design unico e con soluzioni tecnologiche peculiari. Tra i prodotti di maggiore successo, la linea Zefiro ha ottenuto la selezione per il Compasso d'oro.

Alea se concentre sur des collections ciblées qui conjugent design et fonction. Elles sont particulièrement appréciées par les Architectes & Designers. Ayant comme but la qualité et l'innovation, les collections Alea se caractérisent par leur contenu de style et leurs caractéristiques techniques uniques. Les matériaux utilisés et les détails qu'on retrouve dans nos produits nous permettent d'offrir un produit "haute couture".

Alea se concentra en "design-oriented collections", particulièrement apprécié par "A & D community". Buscando calidad e innovación, las colecciones de Alea se caracterizan por su estilo y características técnicas. Los materiales utilizados y los detalles que se encuentran en nuestros productos, nos permite ofrecer un producto de "haute couture".



Environment

ALEA believes that a sustainable business can work for the environment, consumers and employees. In pursuit of this principle we focus our efforts on developing ecologically friendly products and activities. ALEA develops environmentally low impact products, prioritizing the use of recyclable products with low emissions. None of the veneers used by ALEA are mentioned in CITES lists (Convention on International Trade in Endangered Species of Wild Fauna and Flora).



ALEA ha sempre dimostrato particolare attenzione alle conseguenze ambientali della propria produzione industriale.

Questa sensibilità ha fatto sì che i materiali utilizzati per le proprie linee di arredamento siano stati scelti sempre tra quelli maggiormente riciclabili ed ecocompatibili. Tutti i prodotti ALEA sono imballati usando esclusivamente cartone, senza l'inserimento di plastica o poliuretano espanso nei colli in spedizione.

ALEA estime qu'une entreprise pérenne doit travailler pour l'environnement, le consommateur et le salarié. Suivant ce principe, nous concentrons nos efforts sur le développement d'activités avec des produits respectueux de l'environnement. ALEA fournit des produits à faible impact environnemental en utilisant en priorité des produits recyclables. Les panneaux de ALEA appartiennent à la classe E1 concernant l'émission de formaldéhyde. Aucun des placages utilisés par ALEA n'est mentionné dans les listes de la CITES (Convention sur le commerce international des espèces menacées de faune et flore).

ALEA cree que un negocio sostenible puede trabajar para el medio ambiente, clientes y empleados. Perseguendo este principio, concentramos nuestros esfuerzos en el desarrollo de productos y actividades ecológicos. ALEA desarrolla productos de bajo impacto ambiental, con prioridad al uso de productos reciclables. Los paneles de ALEA corresponden a la Clase E1 en términos de emisión de formaldehído. Ninguna de las chapas utilizadas por ALEA se mencionan en las listas de la CITES (Convención sobre el Comercio Internacional de Especies Amenazadas de Fauna y Flora Silvestres).

Ecopacking

Consistent with Green initiatives, all ALEA products are packaged with cardboard only. ALEA has eliminated completely the use of foam and recently purchased a robotized packing line machine that minimizes the use of cardboard per item, thereby significantly reducing the waste of packing material per product. The cartonboard used for the packing is 85% recycled. All ALEA packages are labeled with the ECOPACK logo.



Tutti i prodotti ALEA sono imballati usando esclusivamente cartone, senza l'inserimento di plastica o poliuretano espanso nei colli in spedizione. Una speciale e innovativa macchina in linea, recentemente messa in attivazione, taglia e piega fogli di cartone per comporre l'intero imballaggio, incluse le sponde perimetrali di protezione. In questo modo il materiale di imballaggio può essere facilmente recuperato e riciclato, dal momento che è composto di un unico materiale da smaltire. Tutti i colli ALEA riportano esternamente il logo ECOPACK per sottolineare questa significativa iniziativa.

Cohérente avec les initiatives Green, tous les produits ALEA sont conditionnés en utilisant uniquement du carton, sans mousse et polystyrène dans les colis. Le carton utilisé pour l'emballage est composé de 85% de fibres recyclées. Une machine a été créée pour l'emballage automatique. Elle est très spécifique et novatrice. Elle plie le carton, prépare les parois de protection et emballe automatiquement tous les éléments. Grâce à ce choix, les emballages peuvent être facilement recyclés. Ils sont constitués d'un seul matériau, naturel et non polluant. Tous les cartons ALEA sont marqués avec le logo ECOPACK, en insistant sur l'initiative, qui réduit l'impact sur l'environnement.

Todos los productos de ALEA están embalados utilizando solo cartón eliminando completamente el uso de espuma de poliestireno. El cartón utilizado por el embalaje se puede reciclar por el 85%. Una nueva e innovadora línea de embalaje, pliega y corta el cartón y en automático empaqueta cada bulto. De esta manera, el embalaje puede ser reciclado con facilidad ya que está hecho de un material único, natural y no contaminante. Todos los paquetes de ALEA se firman con el logotipo de ECOPACK, enfatizando esta iniciativa que reduce el impacto sobre el medio ambiente.

Certificates

ALEA has always given the utmost attention to quality control and has been committed to manufacturing products that fully comply with the user's needs. ALEA has certified its Quality System according to UNI EN ISO 9001 and has obtained the UNI EN ISO 14001 Certificate for Environmental Management. We have also successfully obtained the certifications BS OHSAS 18001 Occupational Health and Safety Assessment Series.

Moreover ALEA can supply FSC® (License Code FSC-C1 18323) certified products in according to FSC-STD-40-004 on client demand. ALEA's collections comply with the most severe international standards.



ALEA è in possesso delle Certificazioni Internazionali:
UNI EN ISO 9001 (Sistemi di Gestione per la Qualità)
UNI EN ISO 14001 (Sistemi di Gestione Ambientale)
BS OHSAS 18001 (Sistemi di gestione della tutela della salute e della sicurezza sul posto di lavoro)
Inoltre, su richiesta del cliente, ALEA può fornire prodotti certificati FSC® (License Code FSC-C1 18323) secondo lo standard FSC-STD-40-004.

ALEA a toujours accordé la plus grande attention aux procédures de qualité et s'est engagée vers la fabrication de produits qui se conforment entièrement aux besoins de l'utilisateur. A' ce propos voici les certifications que nous avons obtenues: UNI EN ISO 9001 (Système de gestion de la qualité), UNI EN ISO 14001 (Système de gestion de l'environnement), BS OHSAS 18001 (Système de gestion de la tutelle de la santé et de la sûreté sur le poste de travail)

En plus, sur demande du client, ALEA peut fournir de produits certifiés FSC® (License Code FSC-C1 18323) qui répondent au standard FSC-STD-40-004.

L'ensemble des collections ALEA sont conformes aux normes internationales les plus sévères.

ALEA siempre ha prestado la máxima atención al control de calidad y se ha dedicado a la fabricación de productos que cumplen plenamente con las necesidades del usuario. ALEA ha certificado su sistema de Calidad según la norma UNI EN ISO 9001, ha obtenido el Certificado de Gestión Ambiental UNI EN ISO 14001 y la certificación BS OHSAS 18001 sobre la protección de la salud y seguridad en el lugar de trabajo.

Ademas ALEA puede proveer productos certificados FSC® (License Code FSC-C1 18323) segun la norma FSC-STD-40-004 sobre petición del cliente.

Project Development

Come si realizza un progetto

Comment on realise un projet

Como se realiza un proyecto

Client/Architect

Initial information

- layout
- typicals
- finishes
- budget

1

Il Cliente/Architetto fornisce gli input: layout, tipologie, soluzioni, finiture, budget.

Le Client/Architecte fournit les données: layout, postes types, solutions, finitions, budget.

El Cliente/Arquitecto proporciona las informaciones iniciales: puestos tipo, soluciones, acabados, presupuesto.

Customer service

Receive and interpret information

- analysis
- share information with technical department
- continued client interaction/ updates

2

L'Ufficio Commerciale riceve e interpreta le informazioni: analizza gli input, condivide le informazioni con l'Ufficio Tecnico, interagisce con il cliente per gli aggiornamenti.

Le Service Commercial reçoit et traite les informations: analyse les données, partage les informations avec le BE – interagit avec le client pour les éventuels ajustements à apporter.

El Departamento Comercial recibe e interpreta la información: hace una análisis de la información recibida, comparte la información con el Departamento Técnico, interacciona con el cliente para revisarlo.

Technical department

Technical analysis of provided typical

- typical review
- conversion of design typical to actual components
- technical drawings

3

L'Ufficio Tecnico studia la tipologia selezionata: elabora l'ingegnerizzazione del prodotto, realizza i disegni tecnici finalizzati alla produzione.

Le BE analyse la typologie sélectionnée: étudie et développe le produit de façon industrielle, en réalisant les dessins techniques pour la mise en fabrication.

El Departamento Técnico estudia la muestra elegida – realiza la programación del producto – realiza los dibujos técnicos para la producción

Mock up department

Mock up production

- production of mock up components
- assembly at factory
- shipment/delivery to client

4

La Sezione Prototipi realizza i componenti del mock-up: pre-assembla la campionatura in azienda, lo invia al cliente per l'approvazione.

La Division Prototypes réalise les composants du mock - up: pré-installe à l'usine les prototypes, organise la livraison chez le client pour l'accord définitif.

El Departamento de Prototipos realiza los componentes de la muestra: instala la muestra en fabrica, la envia al cliente para aprobación.

Manufacturing department

Product production

- manufacturing
- shipment and delivery

5

La Produzione si occupa della realizzazione del prodotto che poi viene consegnato al cliente.

La Production s'occupe de la réalisation du produit fini qui sera livré au client dans les délais convenus.

El Departamento de Producción se ocupa de realizar el producto que después se envia al cliente.

Client/Architect. Initial information.

1

WORKSTATION MOCK UP

Components

Worksurface

- (1) Minimal height adjustment worksurface, 27"D x 72" W (28" - 32" height +/-) with metal spacer(s).
- (1) Sit to stand adjustable height desk - 27"(+/-)D x 72" W

Gallery Panel

- 76"W x 50"H x 3/4" thick wood gallery panel with applied fabric tack panel on inside of workstation (leave 3" at top and sides)

Low Storage Credenza

- 54"W x 16"D x 21"H (+/-) Low storage credenza unit with applied seat cushion. 30"W open storage shelf and 24"W lateral drawer accessible from user side with 3"-6" raised metal legs.

Workwall

- Storage components: 12"W x 18"D x 50"H Wardrobe storage tower; 18"W x 18"D x 26"H Box/File; 30"W x 18"D x 26"H Box/File; 30"W x 18"D x 26"H Open storage shelf
- All units to have 3"-6" metal legs; All wood drawers and doors to be full overlay
- 78"W x 18"D Continuous plastic laminate worksurface; 6"H x 78"W x 10"D Open storage shelf in laminate; panel below open and storage shelf to be laminate
- All storage components to be lockable
- 26" high worksurface should have power/datgrommet or wire management trough located in corner as shown at right.

Power and Data Requirements

- Integrated power and data to be concealed in workwall and routed through technology zoned component.
- Power and data accessed at worksurface with top grommet.
- Wiring to be three 120Vac 20A circuits each with dedicated neutrals (no shared neutrals) and shared equipment ground conductor.
- One infeed per cluster of six (typical)

Finishes

Worksurfaces

- Bright white color plastic laminate

Storage Component

- Bright white color plastic laminate or metal

Wood

- Engineered wood to match natural rift cut oak
- Provide alternate gallery panel sample of plastic laminate to match engineered natural rift cut oak: 24"W x 50"H

Panel Fabric & Seat Cushion

- Charcoal gray color to match Maharam- Messenger 458640-008 Bayou

Hardware

- Hardware- satin stainless (or similar) tab pull
- Legs & spacer - satin stainless (or similar)

Accessories

- LED task lamp with occupancy sensor
- Keyboard tray
- Monitor arm - fully adjustable

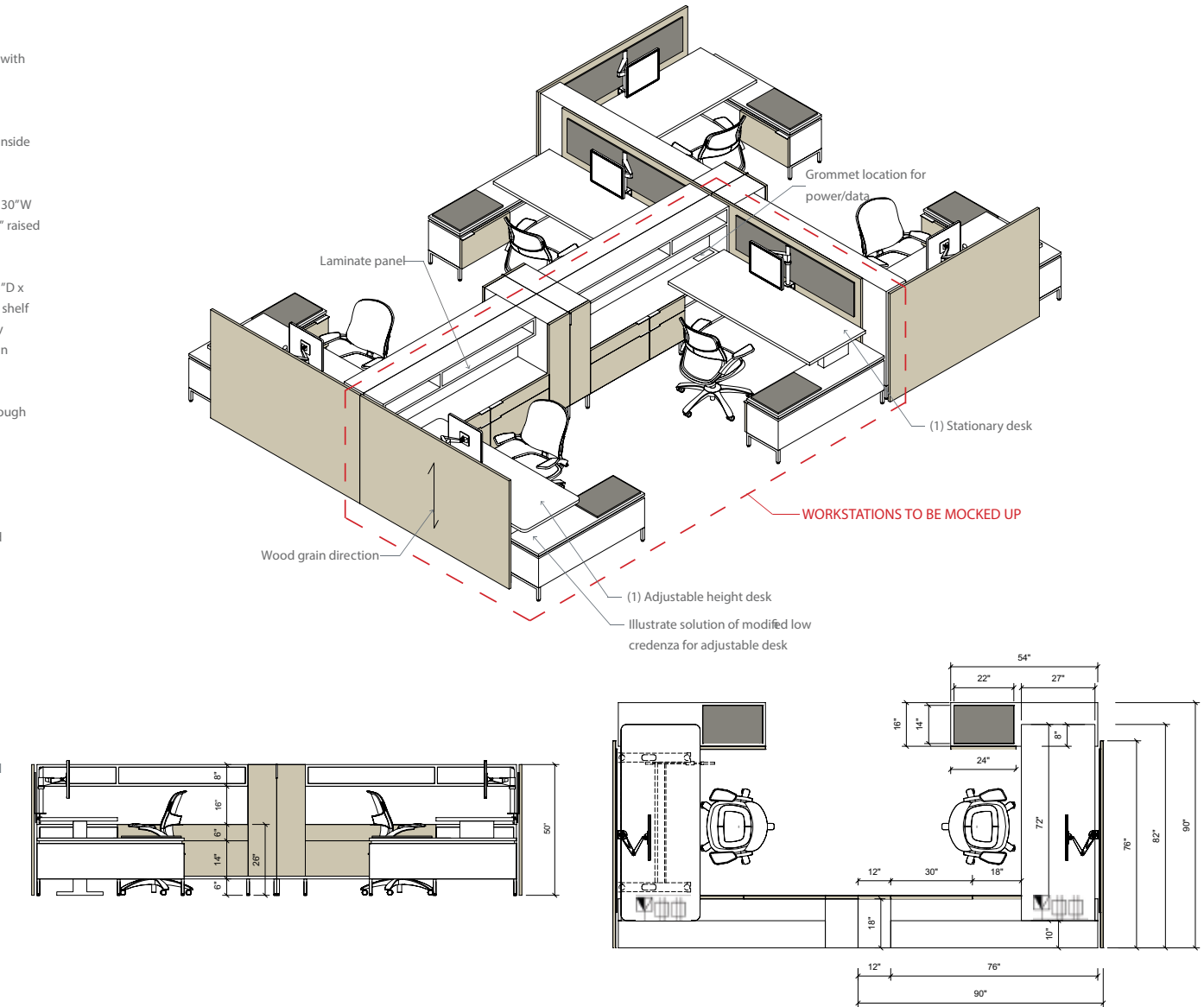

Il Cliente/Architetto fornisce gli input.

Le Client/Architecte fournit les données.

El Cliente/Arquitecto proporciona las informaciones iniciales.

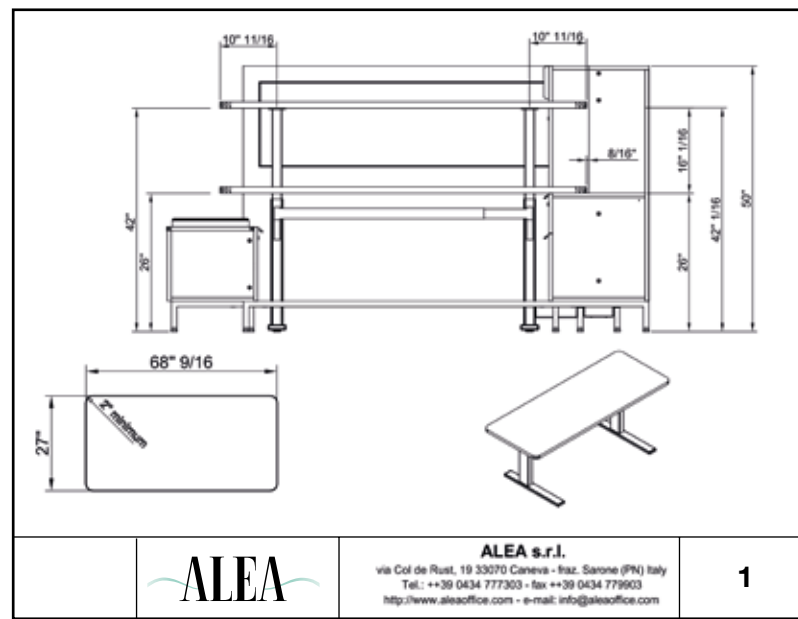
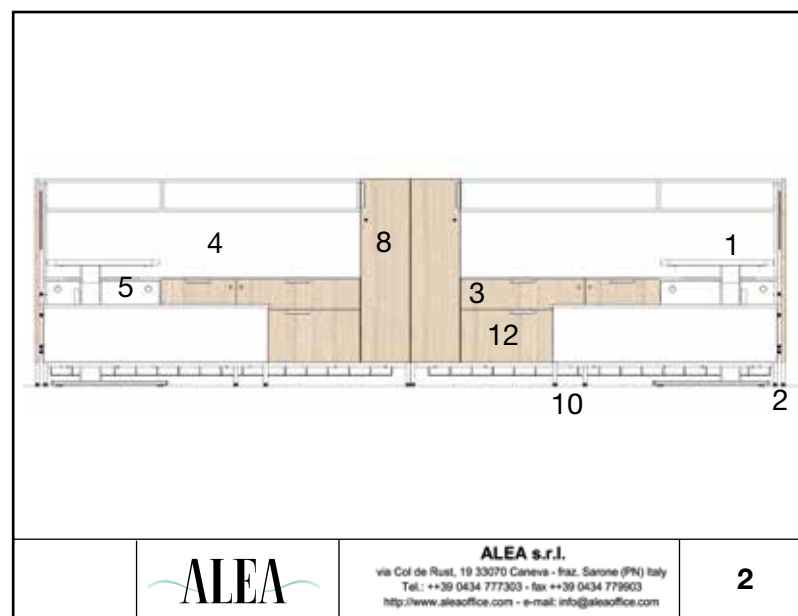

L'Ufficio Commerciale riceve e interpreta le informazioni.

Le Service Commercial reçoit et traite les informations.

El Departamento Comercial recibe e interpreta la información.



L'Ufficio Tecnico studia la tipologia selezionata

Le BE analyse la typologie sélectionnée.

El Departamento Técnico estudia la muestra elegida.



La Sezione Prototipi realizza i componenti del mock-up.

La Division Prototypes réalise les composants du mock - up.

El Departamento de Prototipos realiza los componentes de la muestra.



La Produzione si occupa della realizzazione del prodotto che poi viene spedito al cliente.

La Production s'occupe de la réalisation du produit fini qui sera livré au client dans les délais convenus.

El Departamento de Producción se ocupa de realizar el producto que después se envía al cliente.



Location
Abu Dhabi

Lead consultant shell & core
Obata Kassabaum (HOK)

Interior fit out design consultant
Page Southerland Page (PSP)

Collections
Custom project

Dealer
Mobili/Alea JV

Year
2015

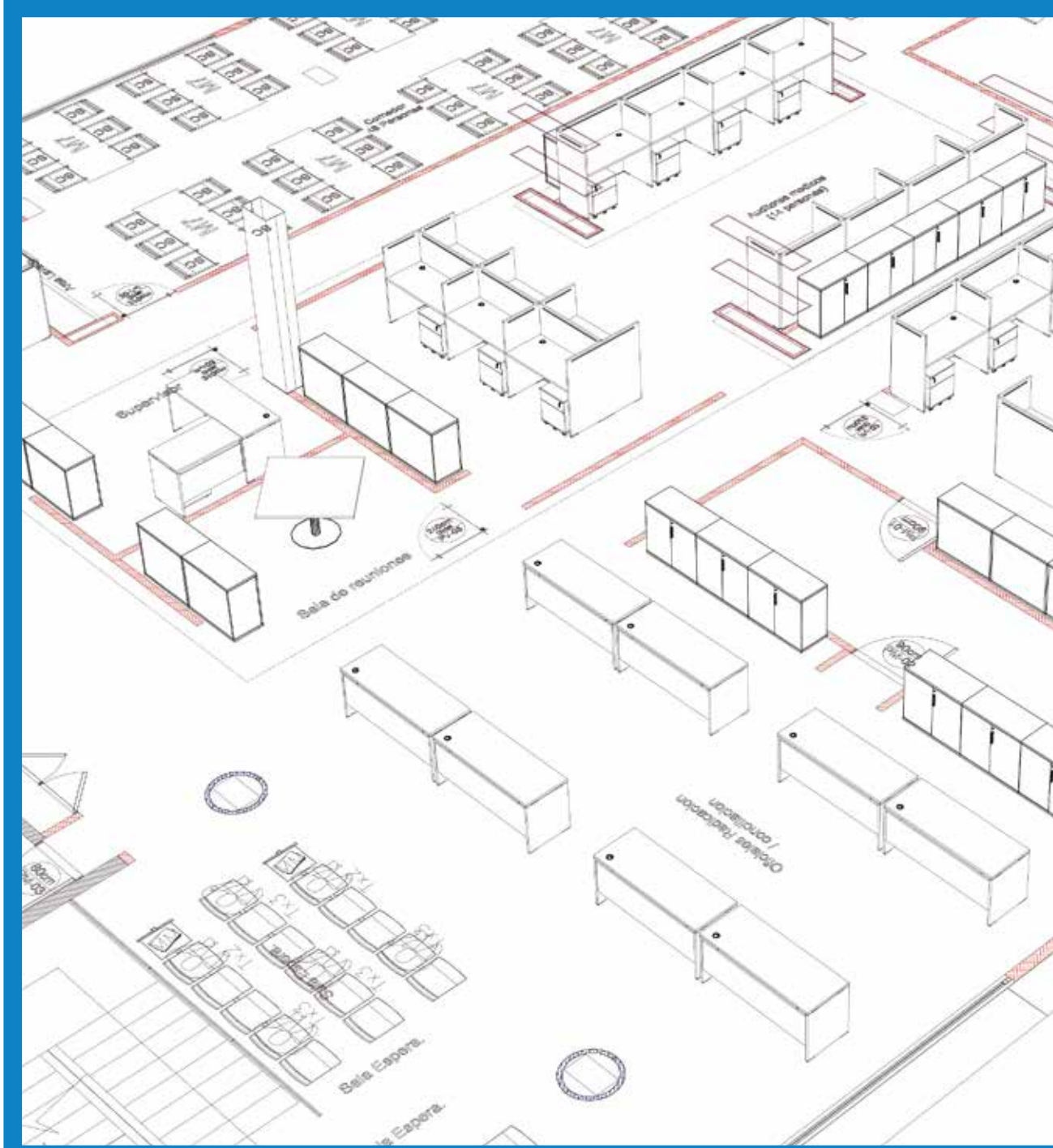









Location
Whippany NJ, Morristown NJ
Washington DC

Architect / Interior Designer
Gensler

Collections
Atlante, Custom project

Dealer
CFI furniture

Year
2012 - 2013 - 2014 and counting

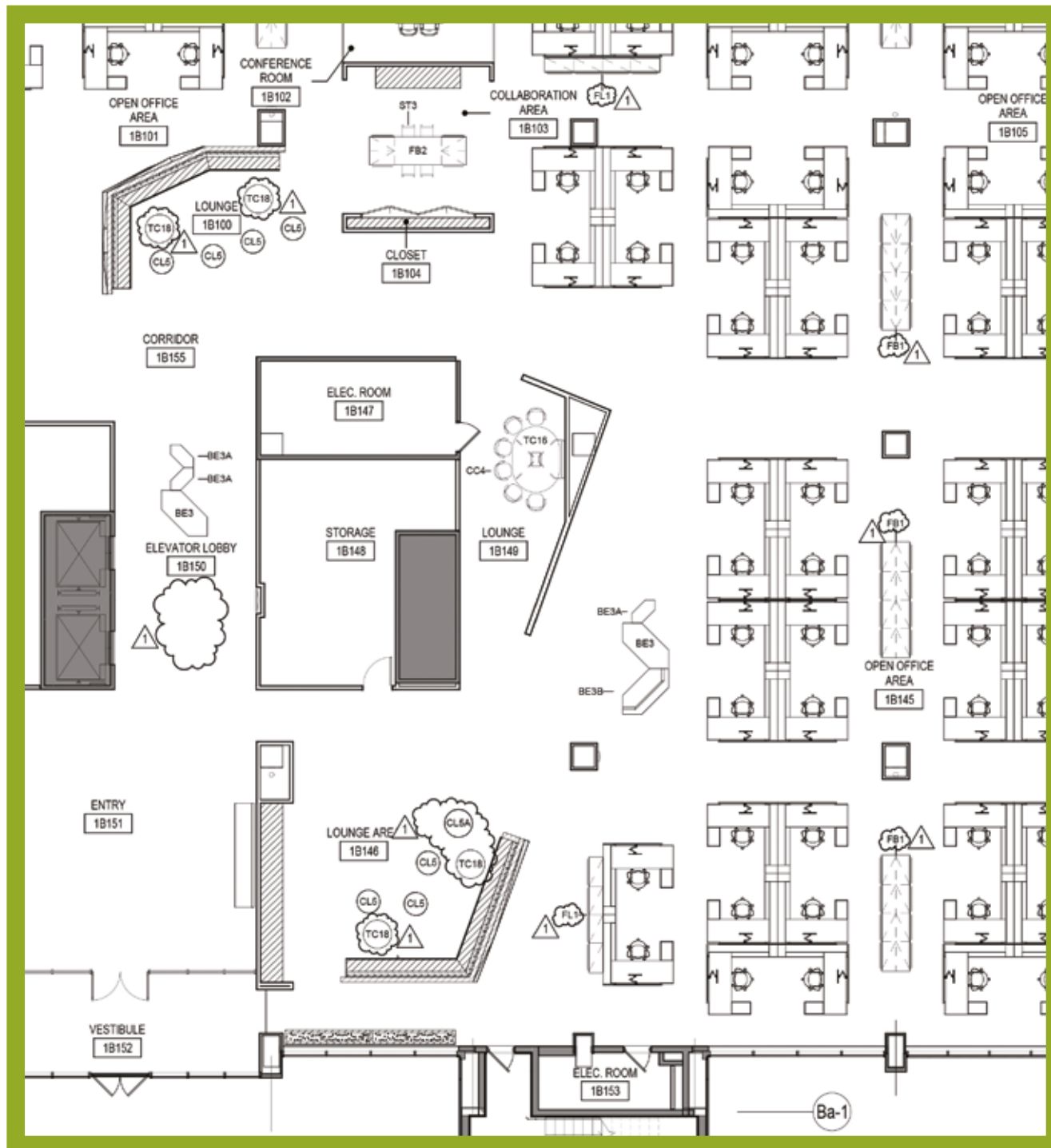









Location
La Valletta - Malta

Architect / Interior Designer
Model

Collections
Atreo, Archimede, Atlante, Italo,
Custom made

Year
2015

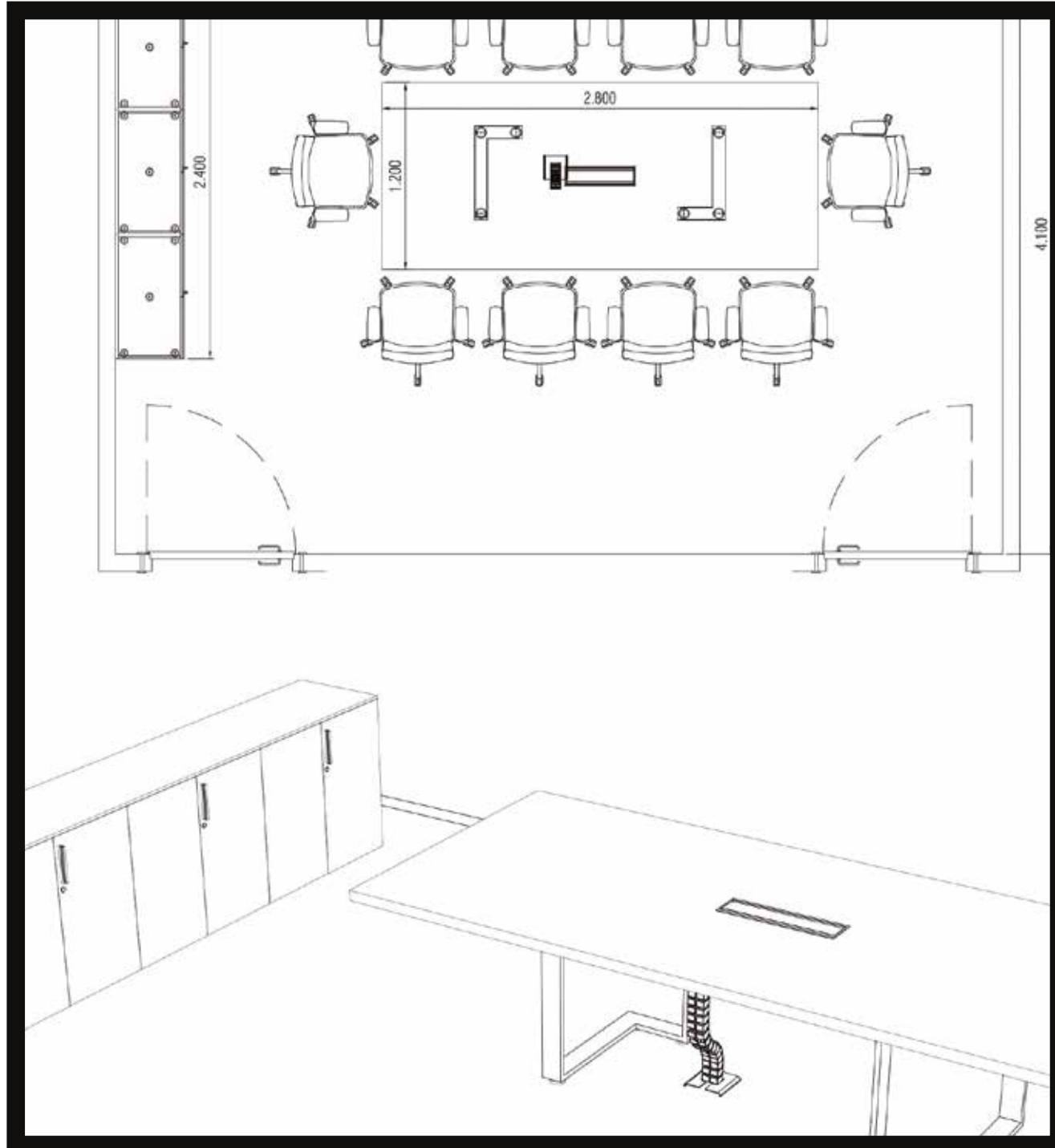



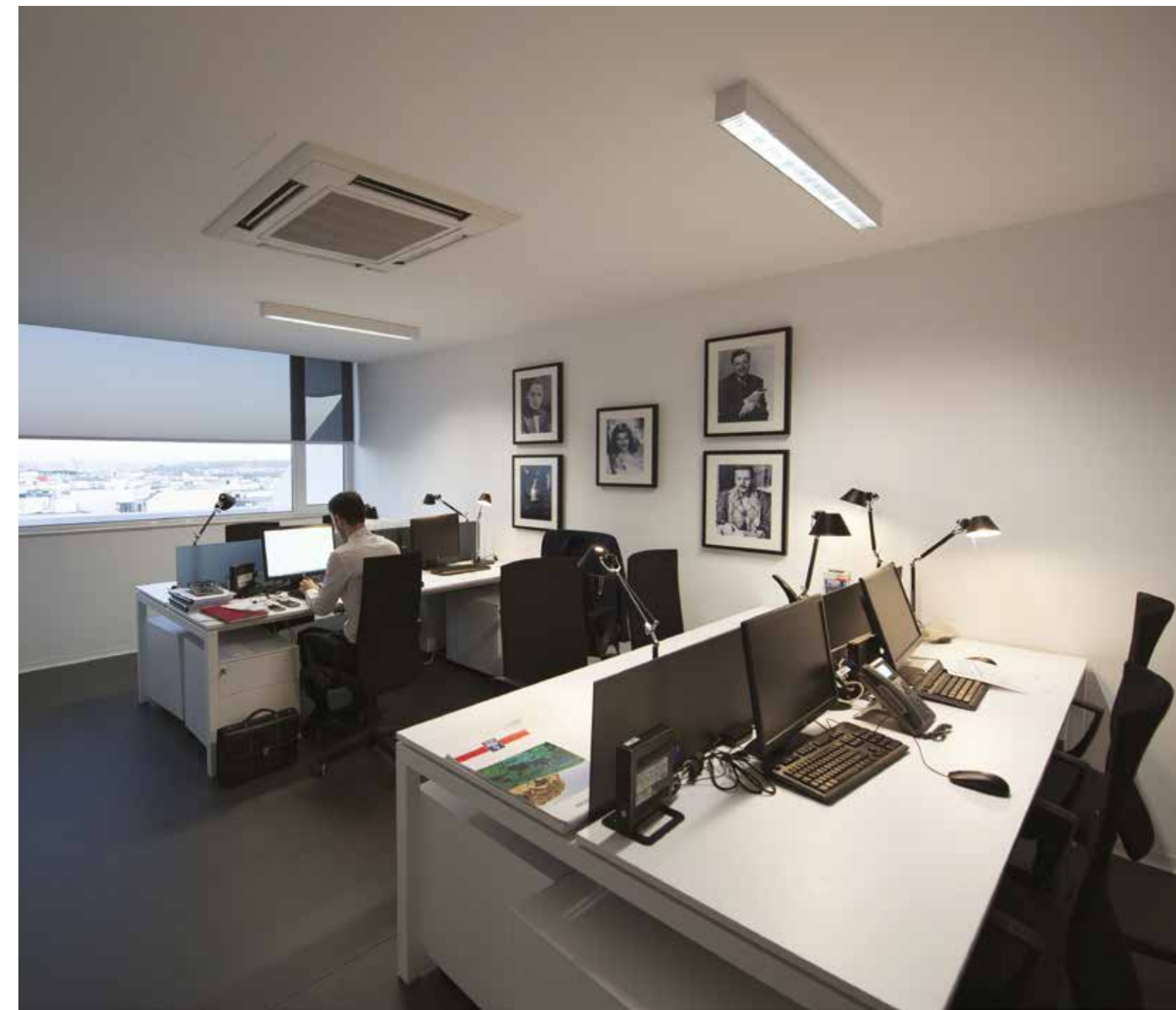
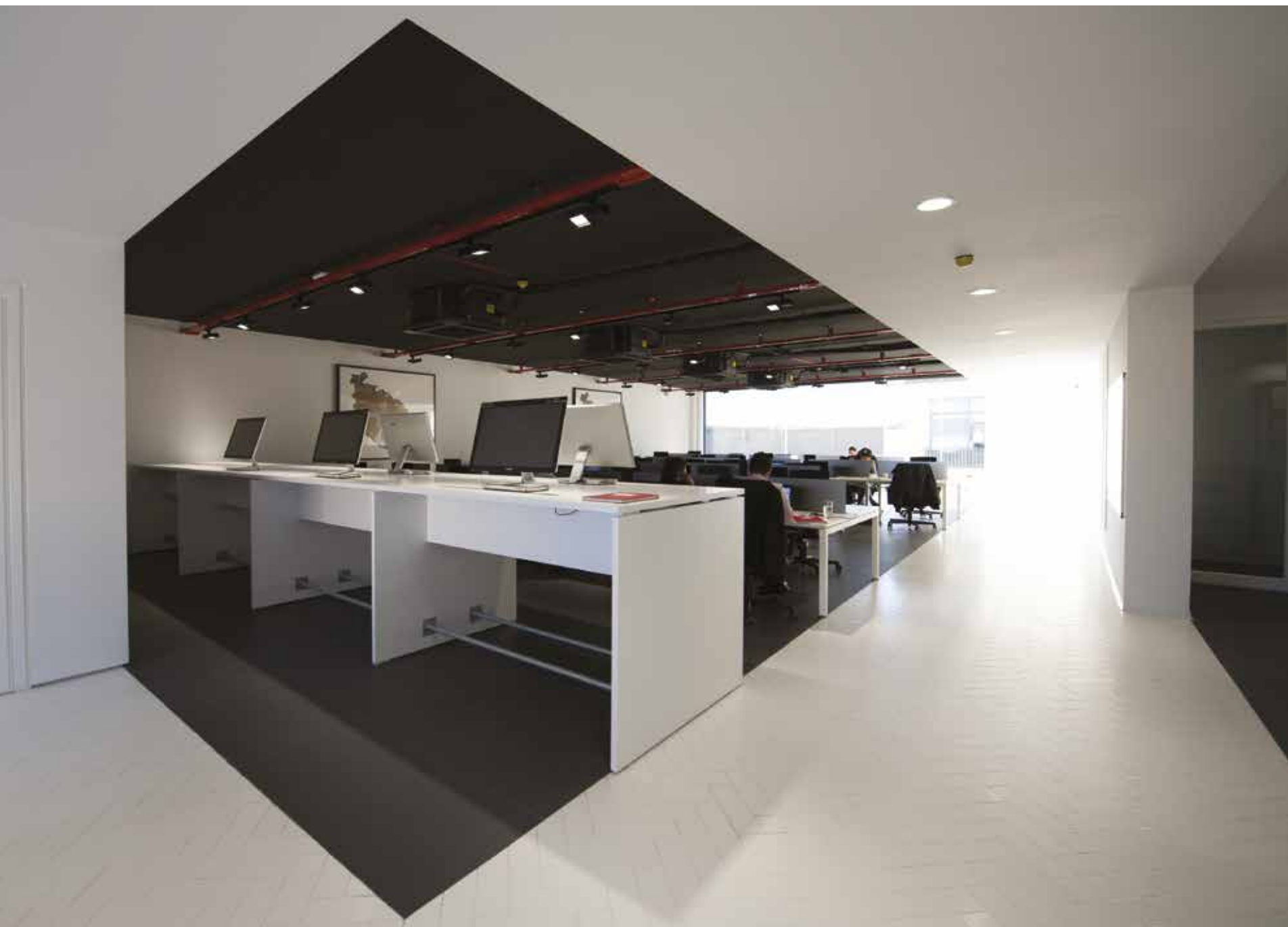

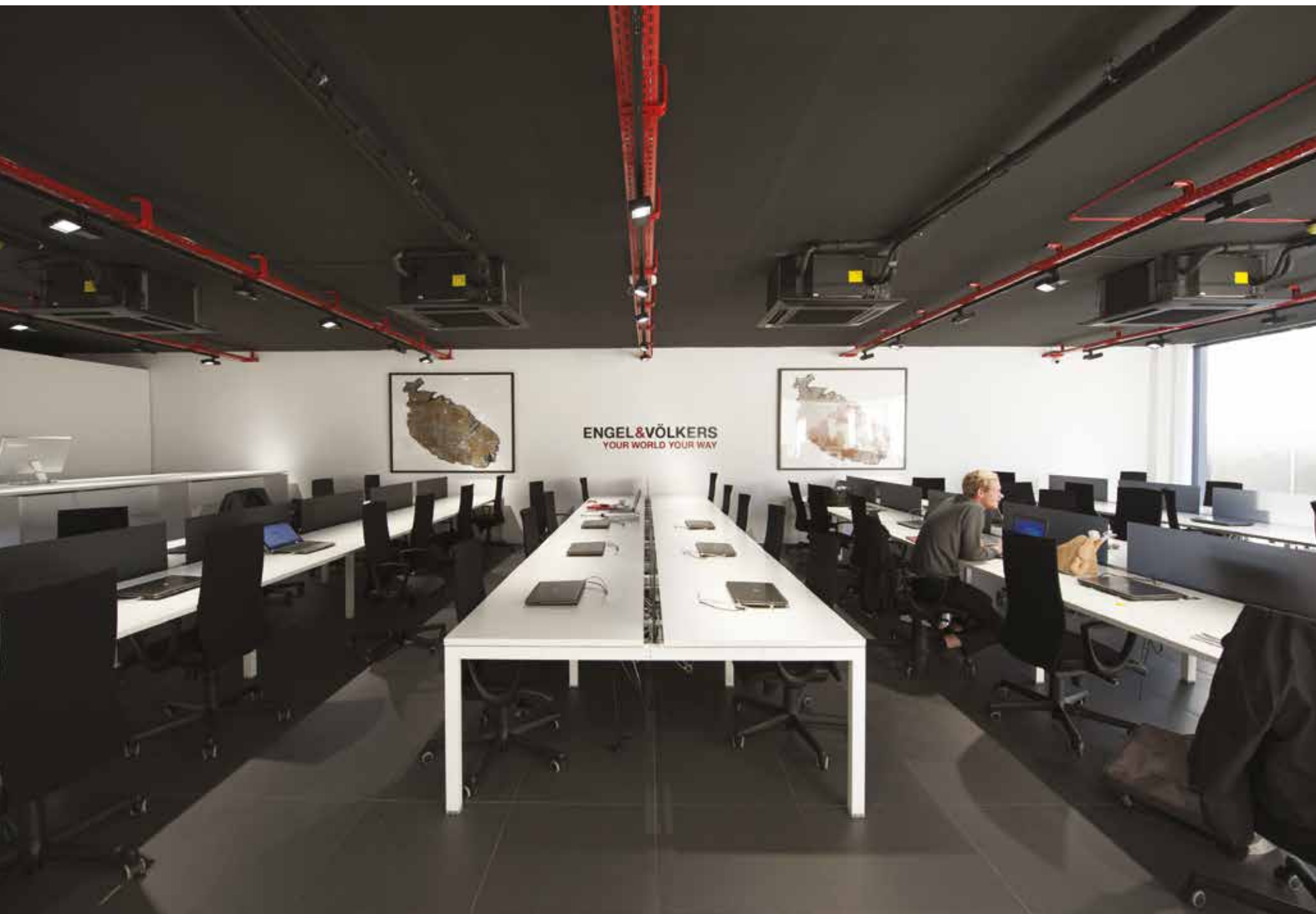

LONDON
& PARTNERS

Location
London

Collections
Atreo, Titano, Archimede

Dealer
Progress Furnishing Systems, Kent

Year
2014

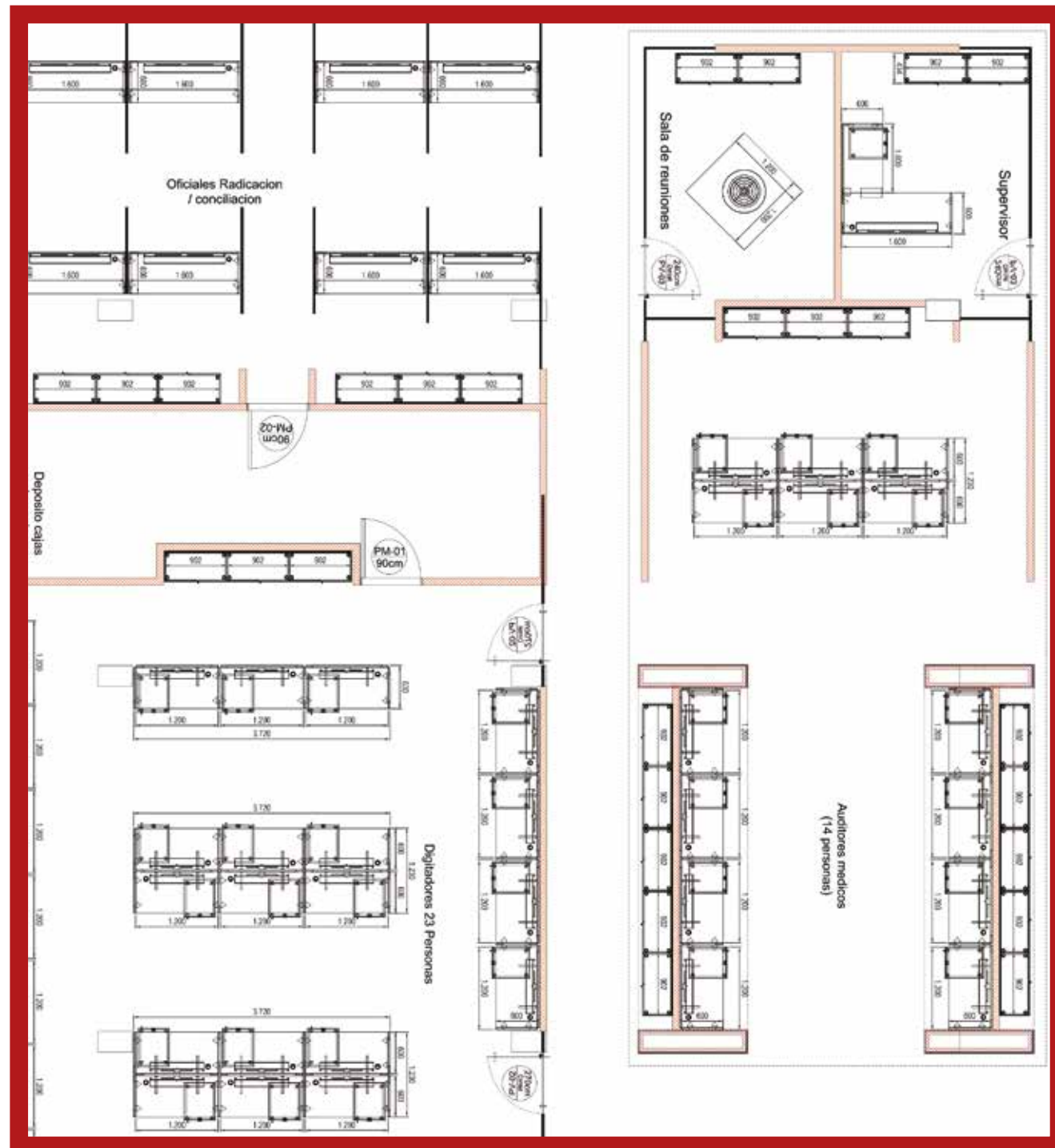









adtrak

Location
Nottingham - UK

Architect / Interior Designer
Working Office

Collections
Atreo, Atlante, Titano

Dealer
Structural Interiors

Year
2014

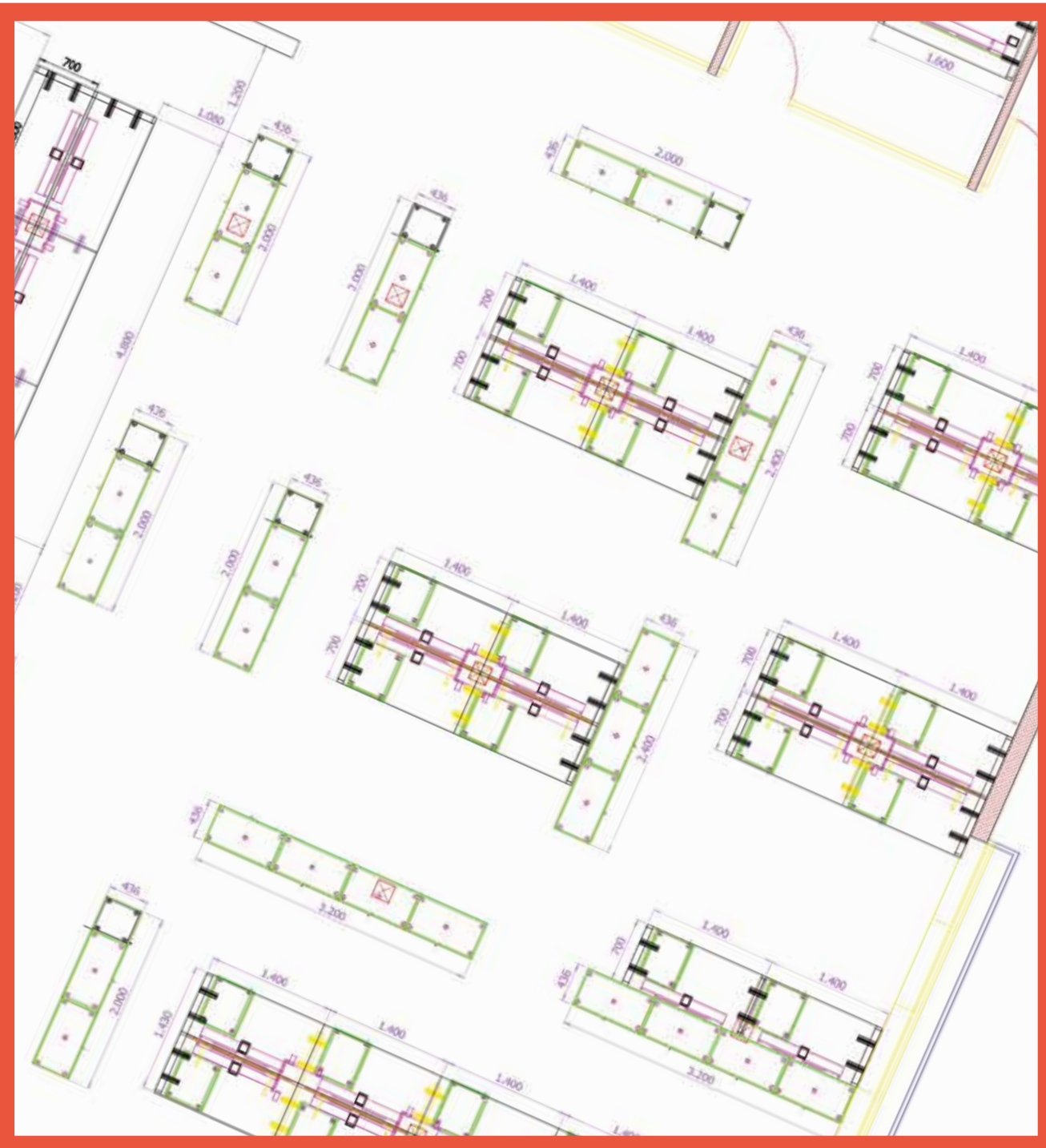



What Are This Lot
Talking About?







Location
Ebene - Mauritius Island
Indian ocean

Architect / Interior Designer
Jean Francois Koenig

Collections
Atreo, Odeon, Eracle,
Custom Made

Dealer
Sieges & Bureaux - Mauritius

Year
2011

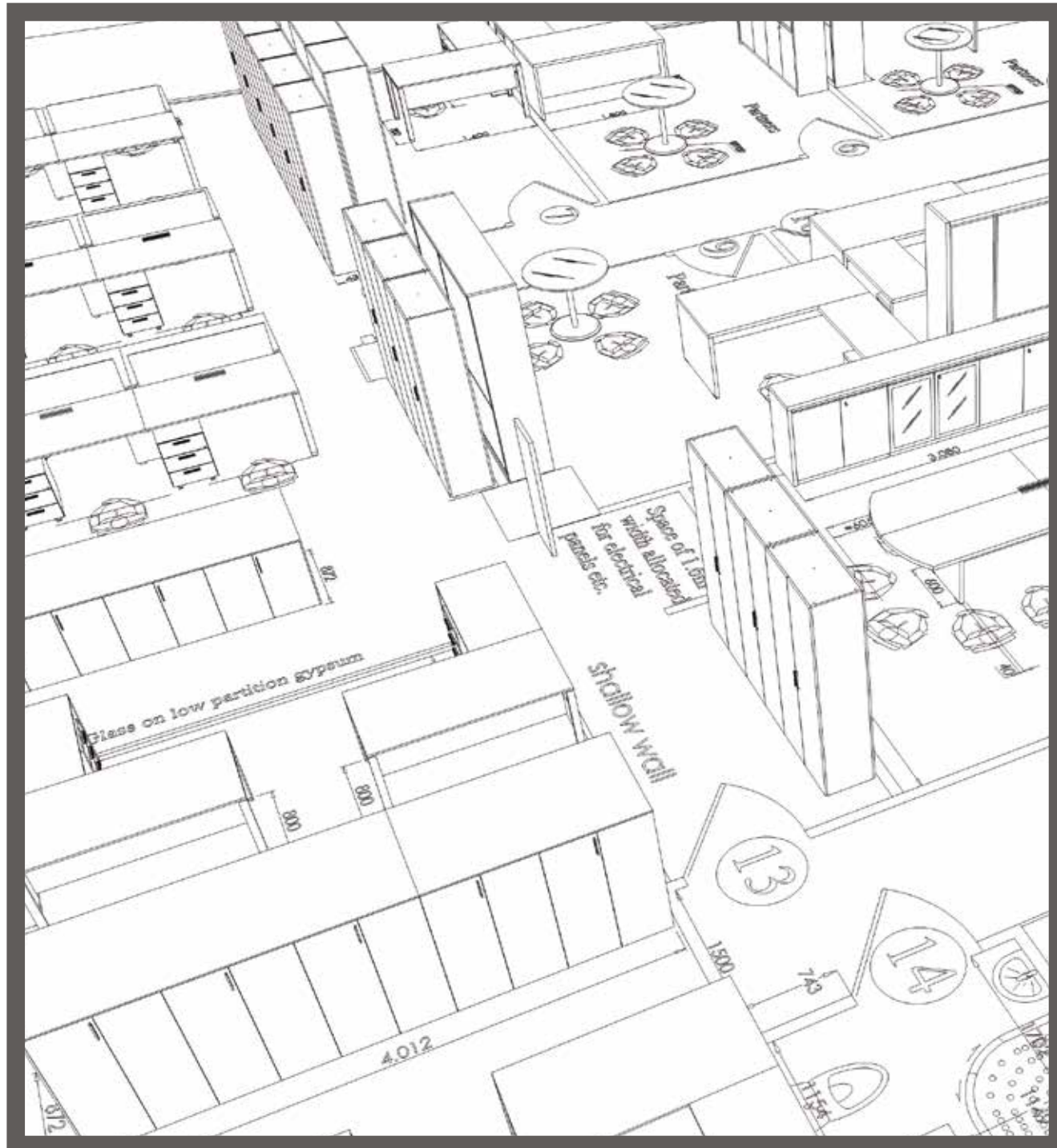





Yammer
The Enterprise Social Network

Location
Old Street - London

Architect / Interior Designer
Progress Furnishing

Collections
Atreo, Zefiro, Archimede

Dealer
Progress Furnishing

Year
2012

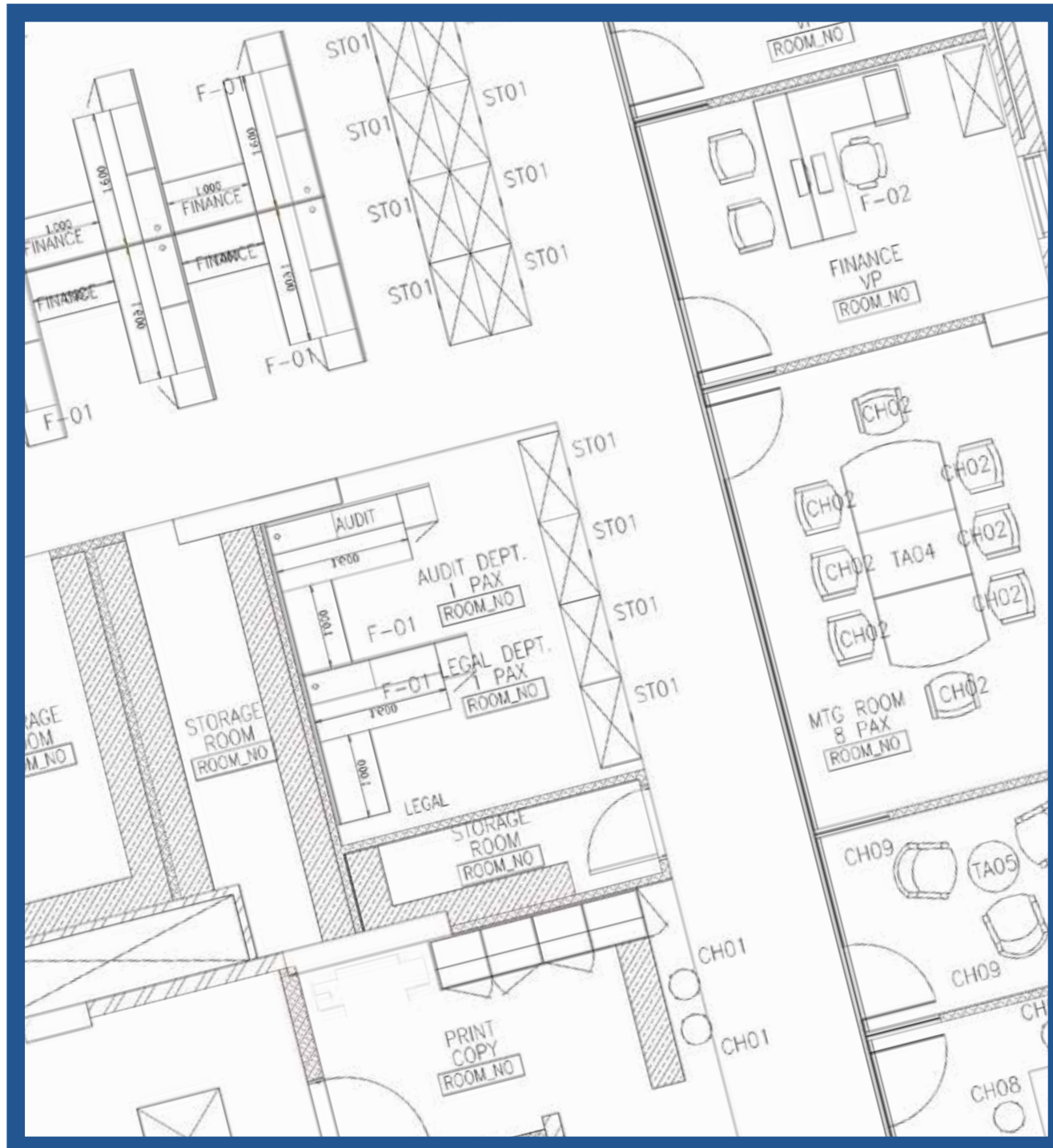











Location
Moscow - Russia

Architect / Interior Designer
DWG Construction Company

Collections
Atreo

Dealer
Solo Office Interiors

Year
2013

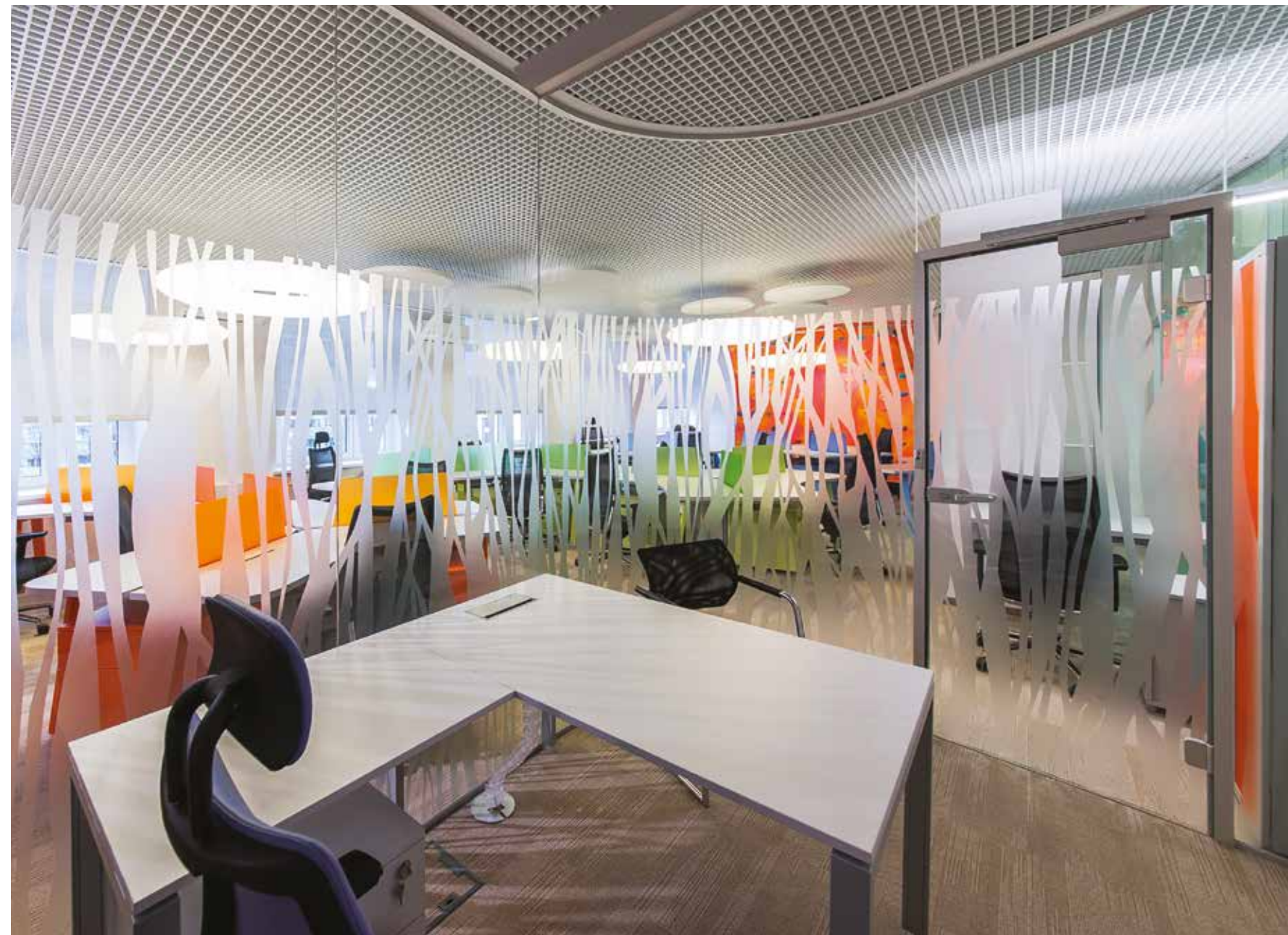





Location
Barlborough - UK

Collections
Archimede, Atreo, Custom made

Dealer
Ovo Spaces

Year
2014 - 2016

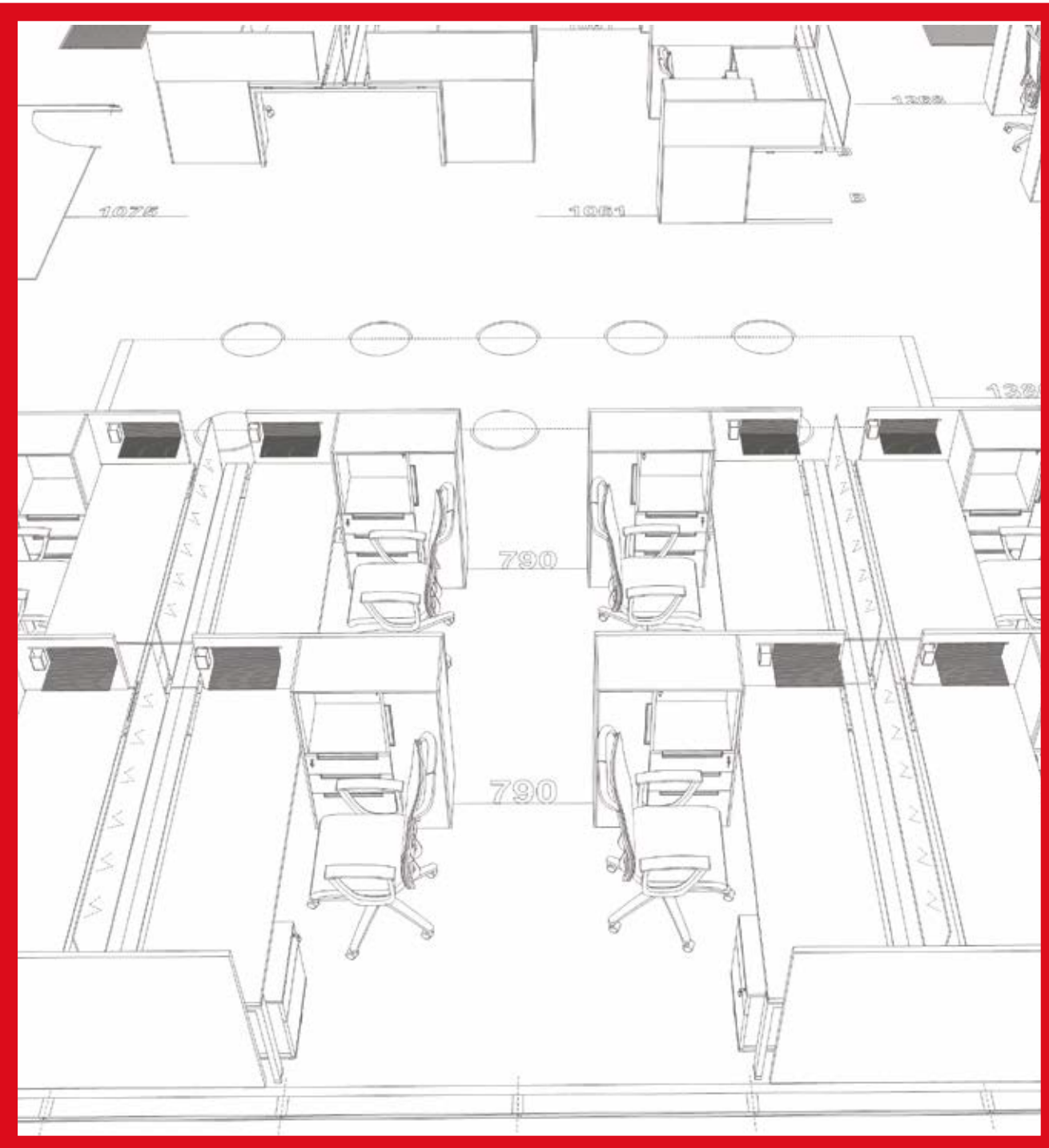









Location
Birmingham - UK

Architect / Interior Designer
Peter Grant Workplace Design

Collections
Atreo,

Dealer
Intex

Year
2015





TETRIS

Location
Maidenhead - UK

Architect / Interior Designer
Tetris Projects

Collections
Atreo

Dealer
Tetris Projects

Year
2014

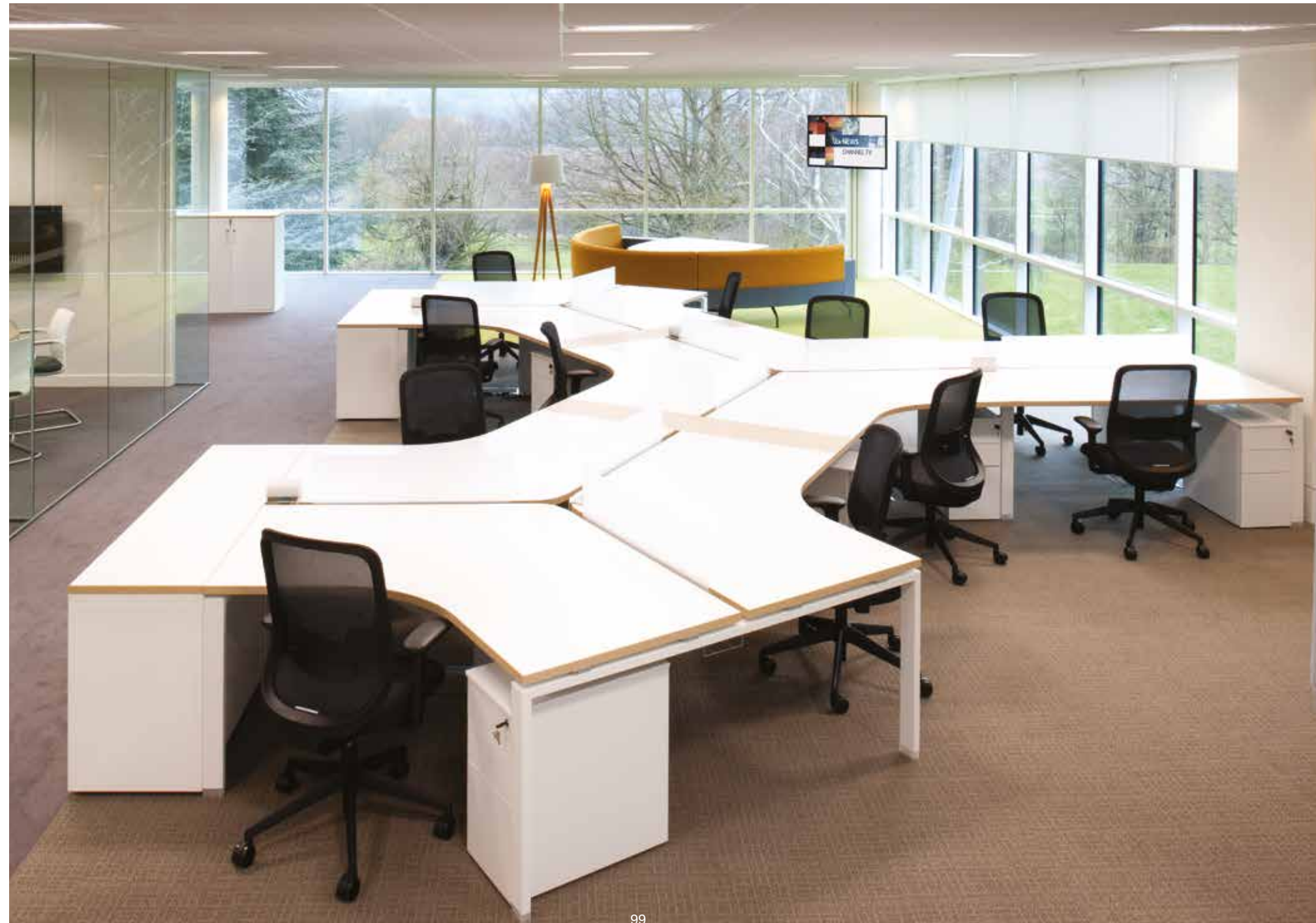







SEGRO

Location
Slough - UK

Architect / Interior Designer
T. P. Bennett

Collections
Atreo, Atlante

Dealer
Phusei

Year
2013





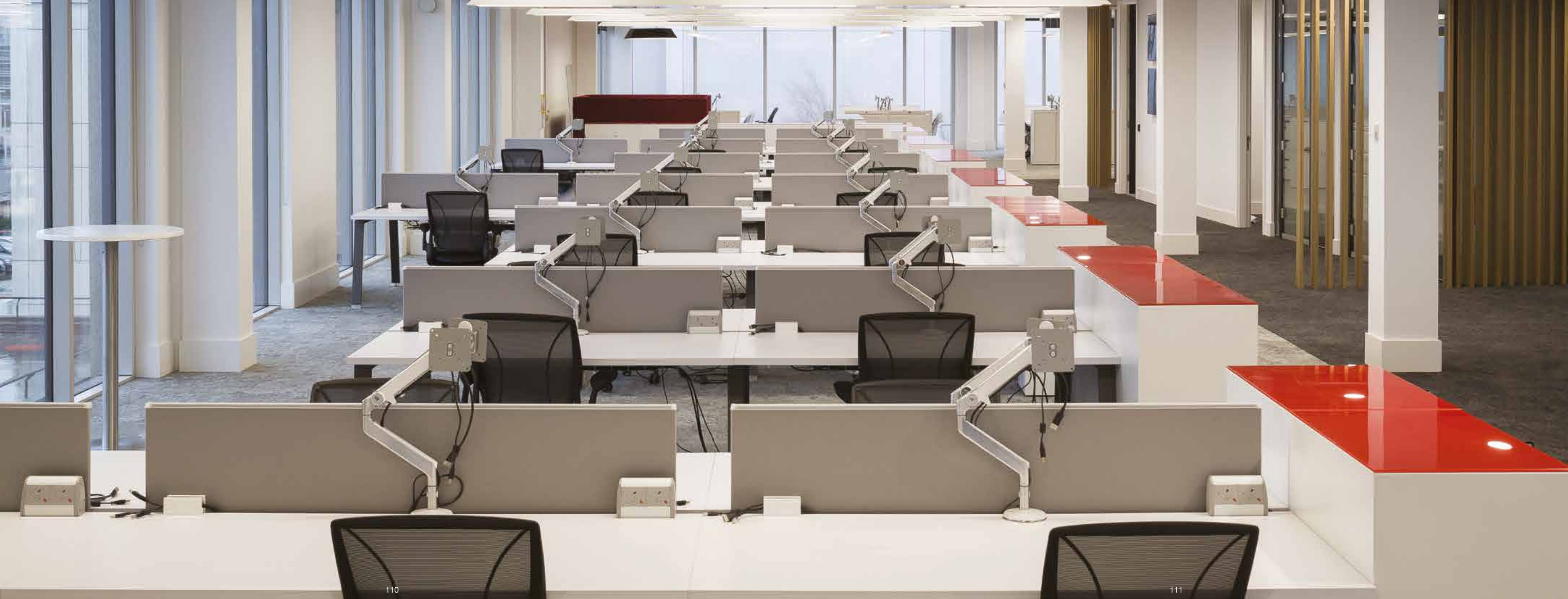



concept, graphic design
Mirto Antonel

foto headquarters
Marco Bettini

BB/CABG/AB

ADNOC HQ (Abu Dhabi, UAE)
BAYER HEADQUARTER (New Jersey, USA)
SKINCARE (Moscow, Russia)
YAMMER (London, UK)
METLIFE INSURANCE (Paris, France)
ADFCA (Abu Dhabi, UAE)
IMG (Atlanta, USA)
CHADBOURNE & PARKE (Dubai, UAE)
DDB (Paris, France)
SONY (Saudi Arabia)
ERICSSON (Paris, France)
GILDEMEISTER (Santiago, Chile)
MCB - MAURITIUS COMMERCIAL BANK (Mauritius Islands)
NOVARTIS (New Jersey, USA)
HAYA WATER (Muscat, Oman)
DOHALAND - MSHRIEB PROPERTY (Doha, Qatar)
JONES DAY (Jeddah - Al Khobar, Saudi Arabia)
INMA BANK (Riyadh, Saudi Arabia)
DAMAN INSURANCE (Abu Dhabi, UAE)
QATAR LUXURY GROUP (Doha, Qatar)
BSB FASHION (Athens, Greece)
RIZON JET (Doha, Qatar)
VODAFONE (Doha, Qatar)
BIC (Athens, Greece)
FERRERO (Alba, Cuneo)
LOADLINE MARINE (Athens, Greece)
ALFA BANK (Moscow, Russia)
URAL AIRLINES (Ekaterinburg, Russia)
UNDP UNITED NATIONS DEVELOPMENT PROGRAM (Abuja, Nigeria)
DELOITTE (Malta)
GHE Gulf House Engineering (Manama, Bahrain)
FOCCHI SPA (Rimini, Italy)
BRITISH AMERICAN TOBACCO (Teheran, Iran)
WASADA UNIVERSITY (Japan)
COSENTINO HQ (Almeria, Spain)
QINVEST (Doha, Qatar)
SOLIDERE (Beirut, Lebanon)
DUBAI POLICE HQ (Dubai, UAE)

REFERENCE LIST



ALEA srl - Via Col de Rust, 19 - 33070 Sarone (PN) - ITALIA
 Tel. ++39.0434.777333 - Fax ++39.0434.779903
 www.aleaoffice.com - e-mail: info@aleaoffice.com

Alea USA Inc
 Midtown 2
 3449 NE 1st Avenue L-32
 Miami, FL 33137
 Tel. 305 470 1200 Fax. 305 470 9070
 www.alea-usa.com - email: info@alea-usa.com

New York City Showroom:
 New York Design Center
 200 Lexington Ave Suite # 1509
 New York, NY 10016

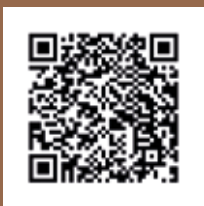

profilo aziendale Bedrijfsprofiel 公司概况 企业概况
 Фирменпрофил 公司概况 公司概况 公司概况
 Εταιρικό προφίλ 公司概况 公司概况
 Företagsprofil 公司概况 公司概况 公司概况
 Фирменный профиль 公司概况 公司概况 公司概况
 Entreprisa 公司概况 公司概况 公司概况