

LOAD DATA SHEET - PAGE 1 OF 3 - AEROPLANE WEIGHT

Aeroplane Type:..... PIPER PA32-300

Registration Marking:..... **VH-CDK** Serial No: 32-40260

ISSUE:.... THREE	DATE:..... 17-Jan-11	EXPIRY:..... INDEFINITE
------------------	----------------------	-------------------------

AEROPLANE WEIGHT AND CENTRE OF GRAVITY DATA:

ITEM	WEIGHT (Kg)	ARM (mm aft of datum)	INDEX UNIT (Kg.mm)	CABIN CONFIGURATION
EMPTY	889.0	1993.4	1772195	SEVEN SEATS TOTAL
OPTIONAL CONFIGURATION WITH CENTRE "JUMP SEAT" HARTZELL HC-C3YR-1RF PROP PER STC SA1791GL				
THE FOLLOWING IMPERIAL UNITS ARE FOR USE WITH THE AIRPLANE FLIGHT MANUAL				
	(lb)	(in)	(in.lb)	
EMPTY	1960.0	78.48	153820	SEVEN SEATS TOTAL

NOTE: The above empty weights include:-

EMPTY - unusable fuel and **full** oil

AeroWeigh Pty. Ltd.
BRUCE BLISSOLD
AUTHORITY NUMBER AN-9
PHONE: 9755 7104 FAX: 9755 7126
MOBILE: 0412 58 5551

LOAD DATA SHEET - PAGE 2 OF 3 - EQUIPMENT LIST

This list details the items included in the empty weight shown in Page 1.

Aeroplane Type:..... PIPER PA32-300
Registration Marking:..... **VH-CDK** Serial No: 32-40260

ISSUE:.... THREE	DATE:..... 17.01.11
------------------	---------------------

ENGINES
Lycoming IO-540..... 1

PROPELLERS
Hartzell HC-C3YR-1RF.... 1

COMPASSES
Magnetic..... 1
Remote Indicating..... 0

THERMOMETERS
Engine Temp(Cyl.Hd.)..... 1
Oil Temp..... 1
Outside Air Temp..... 1

INDICATORS
Airspeed..... 1
Directional Gyro..... 1
Exhaust Gas Temp..... 1
Flight Hour..... 1
Fuel Flow..... 1
Gyro Horizon..... 1
Stall Warning..... 1
Tacho recording..... 1
Trim Indicator..... 2
Turn Co-ordinator..... 1
Vertical Speed..... 1
Assigned Altitude..... 0

RADIO EQUIPMENT (TYPE)
ADF KING KR87
A/P-F/D..... CENTURY IIB
A/P Cpler..... 0
Speakers..... 1
G/slope..... 0
Headsets..... 1
HF Com..... 0
Nav/Com..... KING KLX135A
Audio..... KING KA134
Txponder..... KING KT76A
Encoder..... ACK A-30
DME..... KING KN64
GPS..... 0
Intercom..... FLIGHTCOM 403
Traffic..... MONROY ATD300

INSTRUMENTS
Altimeters..... 1
Ammeters..... 1
Clocks..... 1
Voltmeters..... 0

GAUGES
Engine Oil Pressure..... 1
Fuel Contents..... 4
Fuel Pressure..... 1
Manifold Pressure..... 1
Suction Pressure..... 1

LIGHTS
Anti-collision..... 1
Inst. Full Panel..... 1
Inst. Flood/Spot..... 2
Landing..... 1
Map Reading..... 2
Navigation..... 3
White Strobes (tips)..... 0
Cockpit..... 0
Pax Cabin..... 4

RESTRAINT EQUIPMENT
Inertia Reels..... 2
Lap-sash harnesses..... 2
Lap Belts..... 5

ELECTRICAL EQUIPMENT
Alternators..... 1
Batteries..... 1
Starters..... 1
External Power..... 1

MISCELLANEOUS EQUIPMENT
Dual Controls..... 1
Fire Ext.(Portable)..... 1
Cabin Heater..... 1
Vacuum Pumps..... 1
Heated Pitots..... 1
Alternate Static..... 1
Electric Trim..... 0
Wheel Fairings..... 3

DISPOSABLE LOAD LIST
First Aid Kit..... 0
Torch..... 0
V.S.Beacon/E.L.T..... 0

AeroWeigh Pty. Ltd.
~~BRUCE WICKS SOLD~~
AUTHORITY NUMBER: AN-9
PHONE: 97 55 7104 FAX: 97 55 7126
MOBILE: 0412 58 5551

LOAD DATA SHEET - PAGE 3 OF 3 - LOADING SYSTEM

Aeroplane Type:..... PIPER PA32-300

Registration Marking:..... **VH-CDK** Serial No: 32-40260

ISSUE:..... THREE

DATE:..... 17.01.11

The following is valid only for the Empty Weight specified in Page 1 of 3 Aeroplane Weight dated... 17.01.11 and is based on calculations using Occupant Weights of 84 Kg each.

1. OCCUPANTS:-

Load Front to Rear (i.e. Front seats first)
Load Heaviest Passengers in front row

2. BAGGAGE COMPARTMENT LIMITATIONS:-

<u>Number of Occupants</u>	<u>Nose Baggage</u>		<u>Rear Baggage</u>	
	<u>Minimum</u>	<u>Maximum</u>	<u>Minimum</u>	<u>Maximum</u>
One(pilot)	NIL	45 Kg	NIL	45 Kg
Two	NIL	45 Kg	NIL	45 Kg
Three	NIL	20 Kg	NIL	45 Kg
Four	NIL	NIL	30 Kg	45 Kg
Five	NIL	NIL	25 Kg	45 Kg
Six	NIL	45 Kg	NIL	30 Kg
Seven (Jump Seat)	NIL	NIL	NIL	NIL

3. WING MAIN FUEL:-

All weight in excess of 1411.5 Kg must be fuel weight only

Fuel is limited only by All Up Weight

MAXIMUM TAKE-OFF WEIGHT.....1542 Kg

NOTE: If a full Loading Check is required, refer to Loading Instructions and Tables in the Pilots Handbook or Flight Manual

AeroWeigh Pty. Ltd.
BRUCE W. WOOD
AUTHORITY NUMBER AN-9
PHONE: 9755 7104 FAX: 9755 7126
MOBILE: 0412 58 1551

LOAD CHART BC/PA32/1 Issue 1 PIPER PA32-300 (& 260)

"300" SERIAL NUMBERS 32-40001 through 32-40565 Only

"260" SERIAL NUMBERS 32-1 through 32-1075 Only

BASIC EMPTY WEIGHT	
PILOT/CO-PILOT	
ROW 2/CARGO A	
ROW 3/CARGO B	
NOSE BAGG (MAX 45 Kg)	
REAR BAGG (MAX 45 Kg)	
ZERO FUEL WEIGHT	
WING FUEL	
TAKE-OFF WEIGHT	
FLIGHT FUEL	
LANDING WEIGHT	

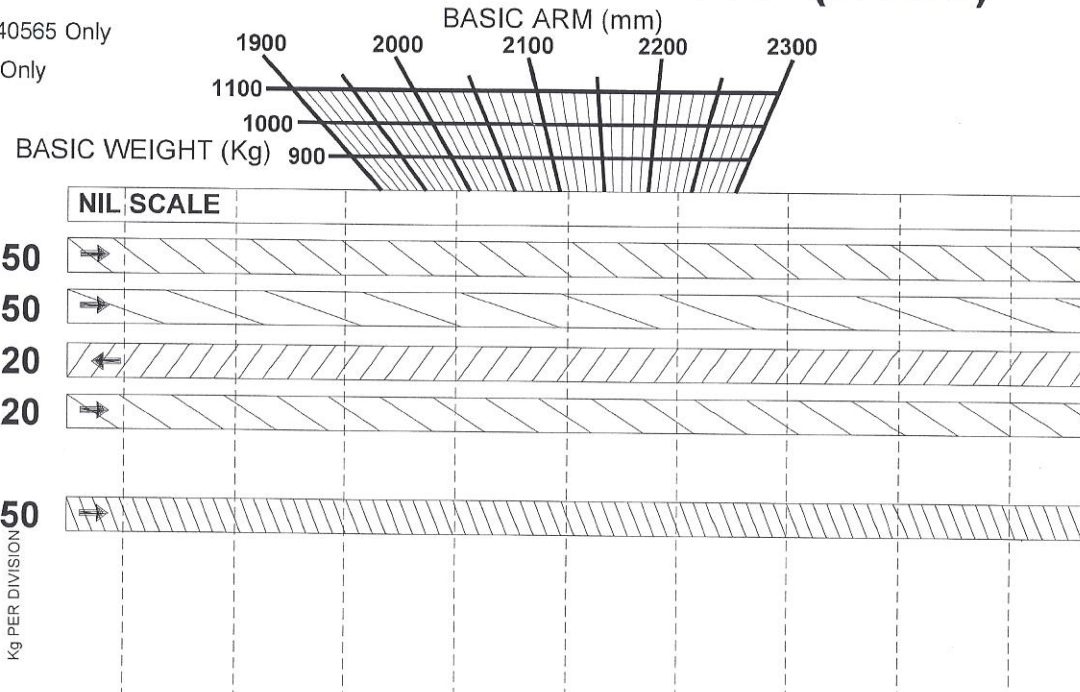

NOTE
ALL WEIGHT IN EXCESS OF
1412 Kg
MUST BE FUEL IN THE WINGS

MAX TAKE-OFF 1542 Kg

MAX CARGO IN LIEU OF ROW TWO SEATS
164 Kg

MAX CARGO IN LIEU OF ROW THREE SEATS
164Kg

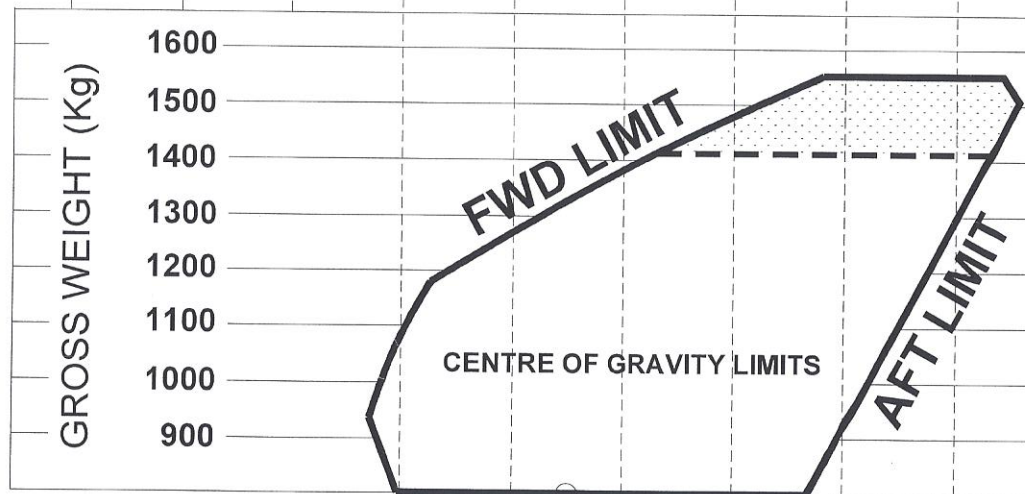

PHONE: 9755 7104
 MOBILE: 0412 311 129
 AUTHORITY: 11/1/04
 SOLD
 11/1/04

© AeroWeigh Pty Ltd