



CHEROKEE SIX 300
INFORMATION MANUAL

1400 lbs
actual
@ 2500' strip
80 f
2 months

CHEROKEE SIX 300 INFORMATION MANUAL

REVISION 4



Cherokee Six 300

PA-32-300

HANDBOOK PART NO. 761-559

A complete or partial replacement of this manual, Part No. 761 559, may be obtained only from Piper Customer Services.

Published by
PUBLICATIONS DEPARTMENT
Piper Aircraft Corporation
761 559
Issued: July 1973

APPLICABILITY

The aircraft serial number eligibility bracket for application of this manual is 32-7440001 through 32-7640130. The specific application of this manual is limited to the Piper PA-32-300 model airplane designated by serial number and registration number on the back of the title page of this manual.

This manual cannot be used for operational purposes unless kept in a current status.

REVISIONS

The information compiled in the Pilot's Operating Manual will be kept current by revisions distributed to the airplane owners.

Revision material will consist of information necessary to update the text of the present manual and/or to add information to cover added airplane equipment.

I. Revisions

Revisions will be distributed whenever necessary as complete page replacements or additions and shall be inserted into the manual in accordance with the instructions given below:

1. Revision pages will replace only pages with the same page number.
2. Insert all additional pages in proper numerical order within each section.
3. Page numbers followed by a small letter shall be inserted in direct sequence with the same common numbered page.

II. Identification of Revised Material

Revised text and illustrations shall be indicated by a black vertical line along the left hand margin of the page, opposite revised, added or deleted material. A line opposite the page number or section title and printing date, will indicate that the text or illustration was unchanged but material was relocated to a different page or that an entire page was added.

Black lines will indicate only current revisions with changes and additions to or deletions of existing text and illustrations. Changes in capitalization, spelling, punctuation or the physical location of material on a page will not be identified by symbols.

III. Original Pages Issued

The original pages issued for this manual prior to revision are given below:

1-1 through 1-4, 2-1 through 2-19, 3-1 through 3-18, 4-1 through 4-7, 5-1 through 5-30, 7-1 through 7-12, 8-1 through 8-2, 9-1 through 9-12, 10-1 through 10-15.

TABLE OF CONTENTS

GENERAL SPECIFICATIONS

DESCRIPTION - AIRPLANE AND SYSTEMS

AIRPLANE FLIGHT MANUAL F.A.A. APPROVED

EMERGENCY PROCEDURES F.A.A. APPROVED

EMERGENCY PROCEDURES

WEIGHT AND BALANCE

LOADING INSTRUCTIONS

OPERATING INSTRUCTIONS

OPERATING TIPS

PERFORMANCE CHARTS

HANDLING AND SERVICING

GENERAL SPECIFICATIONS

Performance	1-1
Weights	1-2
Power Plant	1-2
Fuel and Oil	1-2
Baggage Area	1-2
Dimensions	1-3
Landing Gear	1-3
3-View	1-4

GENERAL SPECIFICATIONS

PERFORMANCE

Published figures are for standard airplanes flown at gross weight under standard conditions at sea level unless otherwise stated. Performance for a specific airplane may vary from published figures depending upon the equipment installed, the conditions of engines, airplane and equipment, atmospheric conditions and piloting technique. Each performance figure below is subject to the same conditions as on the corresponding performance chart from which it is taken in the Performance Charts Section.

GROSS WEIGHTS	3400	2900
Takeoff Ground Run, 10° flaps, sea level (ft)	1050	750
Takeoff Distance Over 50-ft Obstacle, 10° flaps, sea level (ft)	1500	1200
Best Rate of Climb Speed (mph)	105	100
Rate of Climb (ft per min)	1050	1350
Best Angle of Climb Speed (mph)	95	—
Max Speed, sea level (mph)	174*	175*
Max Speed Optimum Altitude, 8,300 ft, 75% power (TAS) (mph)	168*	171*
Service Ceiling (ft)	16,250	20,000
Absolute Ceiling (ft)	18,000	21,500
Cruise Speed at Best Power Mixture (mph)		
65% power, 11,500 ft	163	167
55% power, 15,000 ft	155	163
Range at Best Power Mixture (mi)**		
75% power, 8,000 ft	780	779
65% power, 11,500 ft	845	850
55% power, 15,000 ft	905	935
Cruise Speed at Best Economy Mixture (mph)		
75% power, 8,000 ft	166	169
65% power, 11,400 ft	159	165
55% power, 15,000 ft	149	157
Range at Best Economy Mixture (mi)**		
75% power, 8,000 ft	850	865
65% power, 11,400 ft	945	980
55% power, 15,000 ft	1030	1080
Stalling Speed, flaps down, (CAS) (mph)	63	58
Stalling Speed, flaps up, (CAS) (mph)	71	66
Landing Roll, flaps down, sea level (ft)	630	540
Landing Distance Over 50-ft Obstacle, sea level (ft)	1000	850

*The speed stated is with optional wheel fairings installed. Subtract 3 mph if wheel fairings are not installed.

**No reserve.

CHEROKEE SIX - 300

GROSS WEIGHTS		3400	2900
WEIGHTS			
Standard Empty Weight (lbs)		1824	1824
Maximum Useful Load (lbs)		1576	1076
POWER PLANT			
Engine - Lycoming	(Serial nos. 7440001 through 7640065 and 7640067 through 7640071) IO-540-K1A5 (Serial nos. 7640066, 7640072 and up) IO-540-K1G5		
Rated Horsepower			300
Rated Speed (rpm)			2700
Bore (inches)			5.125
Stroke (inches)			4.375
Displacement (cubic inches)			541.5
Compression Ratio			8.7:1
Dry Weight (pounds)			457
Propeller (Standard)	HC-C2YK-1()/8475-4 or HC-C2YK-1()/8475D-4 or HC-C2YK-1()F/F8475D-4		
(Optional)*	HC-C2YK-1()/8475R-0 or HC-C2YK-1()F/F8475R-0		
Propeller Diameter (inches) (Standard)			80
(Optional)			84
FUEL AND OIL			
Fuel Capacity (inboard) (U.S. gal)			50
With Standard Auxiliary (U.S. gal)			84
Oil Capacity (U.S. qts)			12
Fuel, Aviation Grade (min octane)			100/130
BAGGAGE			
	Forward	Aft	
Maximum Baggage (lbs)	100	100	
Baggage Space (cubic ft)	8	20	
Baggage Door Size (in.)	16 x 22		

*Serial nos. 7440001 thru 7540188 only

DIMENSIONS

Wing Span (ft)	32.8
Wing Area (sq ft)	174.5
Wing Loading (lbs per sq ft)	19.5
Length (ft)	27.7
Height (ft)	8.2
Power Loading (lbs) per hp)	11.3

LANDING GEAR

Wheel Base (ft)	7.8
Wheel Tread (ft)	10.6
Tire Pressure (lbs)	Nose
	Main
	28-30
	35-40

CHEROKEE SIX-300

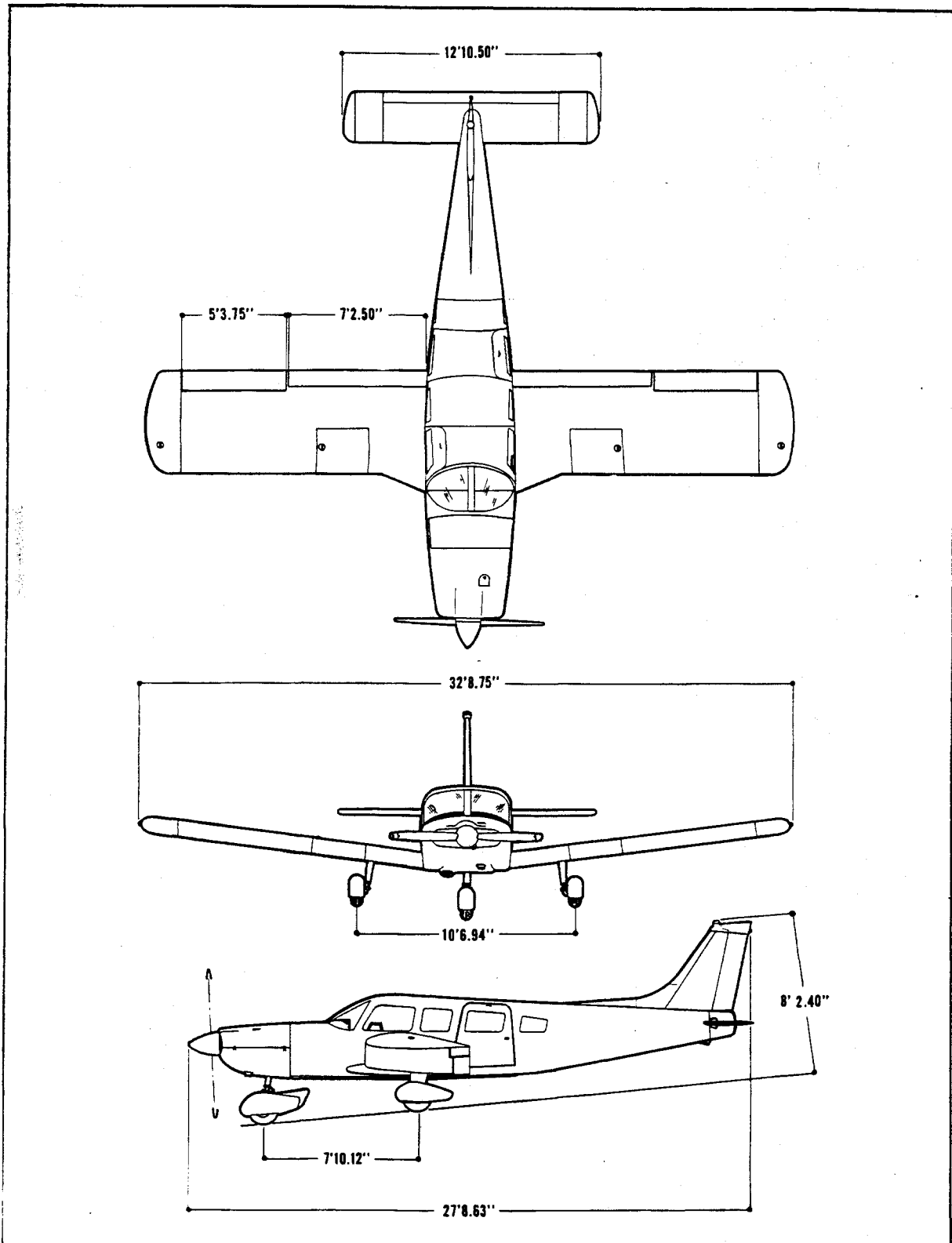

DESCRIPTION

AIRPLANE AND SYSTEMS

The Airplane	2-1
Airframe	2-1
Engine and Propeller	2-1
Induction System	2-2
Landing Gear	2-4
Flight Controls	2-6
Fuel System	2-7
Electrical System	2-9
Vacuum System	2-13
Instrument Panel	2-13
Pitot-Static System	2-15
Heating and Ventilating System	2-15
Cabin Features	2-15
Baggage Area	2-18
Stall Warning	2-18
Finish	2-18
Air Conditioning	2-18
Piper External Power	2-19

DESCRIPTION

AIRPLANE AND SYSTEMS

THE AIRPLANE

The PA-32-300 is a six-place (seventh seat optional), single-engine, low-wing, all metal monoplane. Removable seats give the airplane a wide range of cargo and passenger loading options. Its large capacity, combined with an economical and powerful fuel injected 300 horsepower engine, makes this Cherokee a versatile airplane for personal or commercial use.

AIRFRAME

Except for the tubular steel engine mount, steel landing gear struts, other miscellaneous steel parts, and the dent resistant fiberglass extremities - cowling and tips of wings and tail surfaces - the **basic airframe** is of aluminum alloy.

The **fuselage** is a conventional semi-monocoque structure with a cabin door on the right front and a cargo and passenger door on the left rear.

The **wings** are attached to each side of the fuselage by the insertion of the butt ends of the mainspars into a spar box carry-through which is an integral part of the fuselage structure. This provides, in effect, a continuous main spar with splices at each side of the fuselage. There are also fore and aft attachments at the rear spar and at an auxiliary front spar.

The **wing airfoil section** is a laminar flow type, NACA65₂-415 with a maximum thickness at about 40% aft of the leading edge.

The **empennage** consists of the fin, the stabilator, and the stabilator trim tab.

ENGINE AND PROPELLER

The **Lycoming IO-540-K1A5** (Serial nos. 7440001 through 7640065 and 7640067 through 7640071 or **IO-540-K1G5** (Serial nos. 7640066, 7640072 and up) **engine** installed in the PA-32-300 is rated at 300 horsepower at 2700 rpm. This engine has a compression ratio of 8.7 to 1 and required 100/130 minimum octane fuel. The engine is equipped with a geared starter, a 60 ampere alternator, dual magnetos, vacuum pump drive, a vane-type fuel pump, and fuel injection.

The **exhaust system** consists of dual exhaust stacks routed to a single heavy gauge stainless steel muffler on serial numbers 7440001 through 7540188. On later models individual exhaust pipes are routed in pairs to three heavy gauge stainless steel mufflers. Exhaust gases are routed overboard at the underside of the engine cowling. The muffler (or mufflers) are surrounded by a shroud which provides heat for the cabin and for windshield defrosting.

Cowling on the Cherokee Six is designed to cool the engine in all normal flight conditions, including protracted climb, without the use of cowl flaps or cooling flanges.

The **constant speed propeller** is a Hartzell HC-C2YK-1 ()F/F8475D-4 with a diameter of 80 inches. The propeller is controlled by a governor mounted at the left forward side of the crankcase. The governor is operated by a cable from the power control quadrant.

The **power control quadrant** located in the lower center of the instrument panel includes throttle, mixture, and propeller controls. A **friction lock** on the right side of the quadrant prevents creeping of the controls. In addition, the mixture control has a lock* to prevent activation of the mixture control instead of the pitch control. For information on the leaning procedure, see the **Avco-Lycoming Operator's Manual**.

INDUCTION SYSTEM

On Serial Numbers 7440001 through 7540188, the Induction Air for the engine enters an opening in the nose cowl below the propeller and is picked up by a large air duct. The air is directed through a filter and on to the servo regulator. Should the filter become blocked, a spring-loaded door in the air box between the filter and the servo regulator opens automatically. The door may also be opened manually by a control located on the right side of the quadrant.

On Serial Numbers 7640001 and up, an induction scoop is located on the left side of the lower cowl. An intake air box is attached to the inside of the cowl adjacent to the air filter box. The filter box is located at the aft end of the induction scoop. Access to the filter is gained through a detachable plate located on the outside of the lower cowl. The intake air box incorporates a manually operated two-way valve designed to allow induction air either to pass through the filter or to bypass the filter and supply heated air directly to the engine.

Alternate air selection insures induction air flow should the filter become blocked. Since the air is heated, the alternate air system offers protection against induction system blockage caused by snow or freezing rain, or by the freezing of moisture accumulated in the induction air filter. Alternate air is unfiltered; therefore, it should not be used during ground operation when dust or other contaminants might enter the system. The primary (through the filter) induction source should always be used for takeoffs. On serial numbers 7640001 and up, the control is operated by pressing the knob to the left to clear the retaining gate and then moved in the desired direction.

The Bendix RSA-10ED1 type fuel injection system consists of a servo regulator which meters fuel flow in proportion to airflow to the engine, giving the proper fuel-air mixture at all engine speeds, and a fuel flow divider which receives the metered fuel and accurately divides the fuel flow among the individual cylinder fuel nozzles.

A combination fuel flow indicator and manifold pressure gauge is installed in the left side of the instrument panel. The fuel flow indicator is connected to the fuel flow divider and monitors fuel pressure. The instrument converts fuel pressure to an accurate indication of fuel flow in gallons per hour and percentage of cruise power.

*Serial nos. 7540001 and up

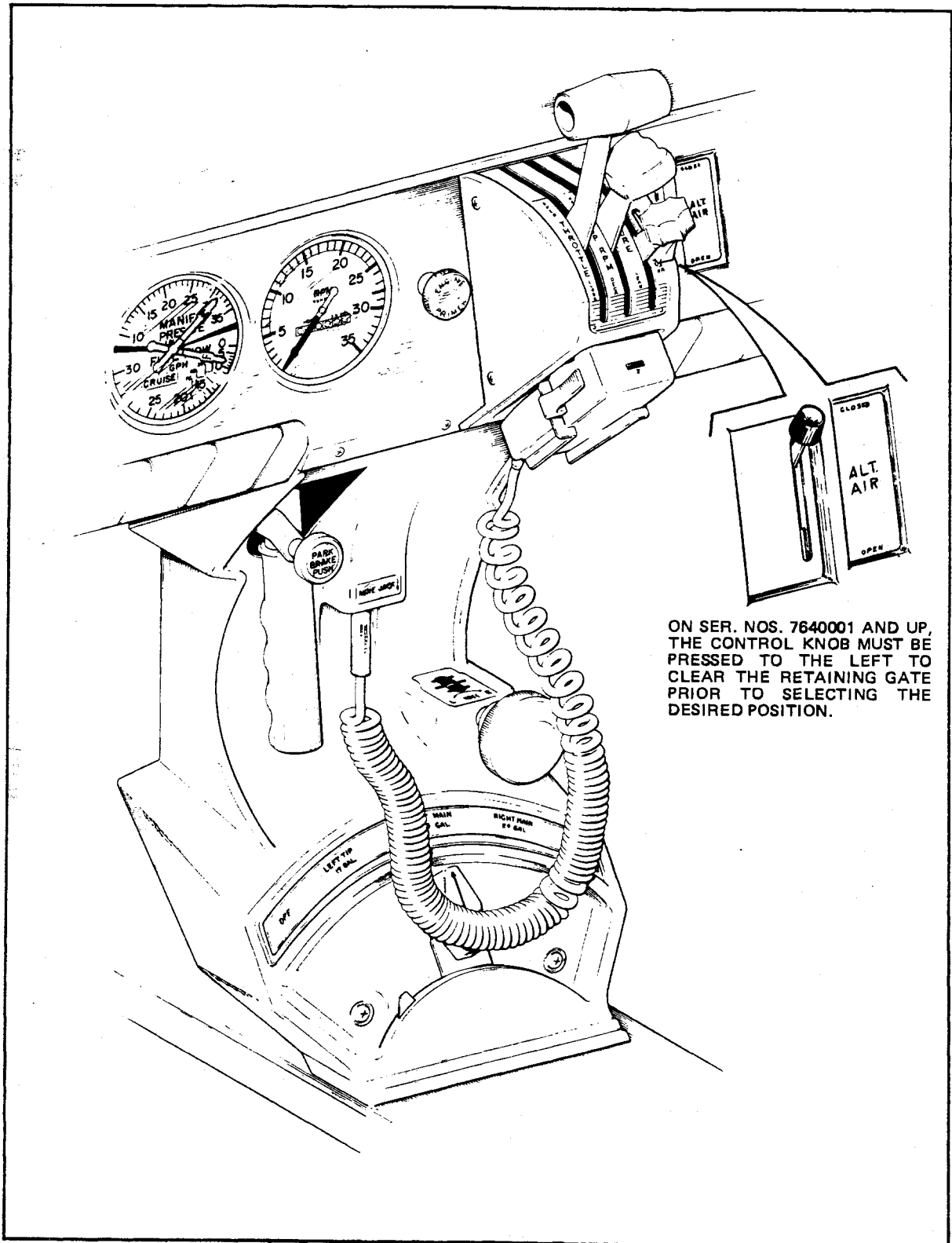

Throttle Quadrant and Console

LANDING GEAR

All three landing gear use Cleveland 6.00 x 6 wheels. The main gear have brake drums and Cleveland double disc hydraulic brake assemblies. The nose wheel carries a 6.00 x 6 four or six ply tire and the main gear use 6.00 x 6 six ply tires. All three tires are tube type.

The nose gear is steerable using a combination of full rudder pedal travel and brakes. The nose gear can be turned 24° each side of center. A spring device is incorporated in the rudder pedal torque tube assembly to aid in rudder centering and to provide rudder trim. The nose gear also includes a shimmy dampener.

The oleo struts are of the air-oil type. The normal extensions are 3-1/4 inches for the nose gear and 4-1/2 inches for the main gear under normal static load (empty weight of airplane plus full fuel and oil).

The brakes are operated by toe pedals attached to the left rudder pedals or by a hand lever and master cylinder located below and behind the left center of the instrument sub-panel. Optional toe brakes are available for the right rudder pedals. Hydraulic cylinders are located above each pedal and adjacent to the hand lever. The brake fluid reservoir is on the top left front of the fire wall. The parking brake is incorporated in the lever brake and is engaged by pulling back on the lever and depressing the knob attached to the top of the handle. To release the parking brake, pull back on the brake lever to disengage the catch; then allow the handle to swing forward.

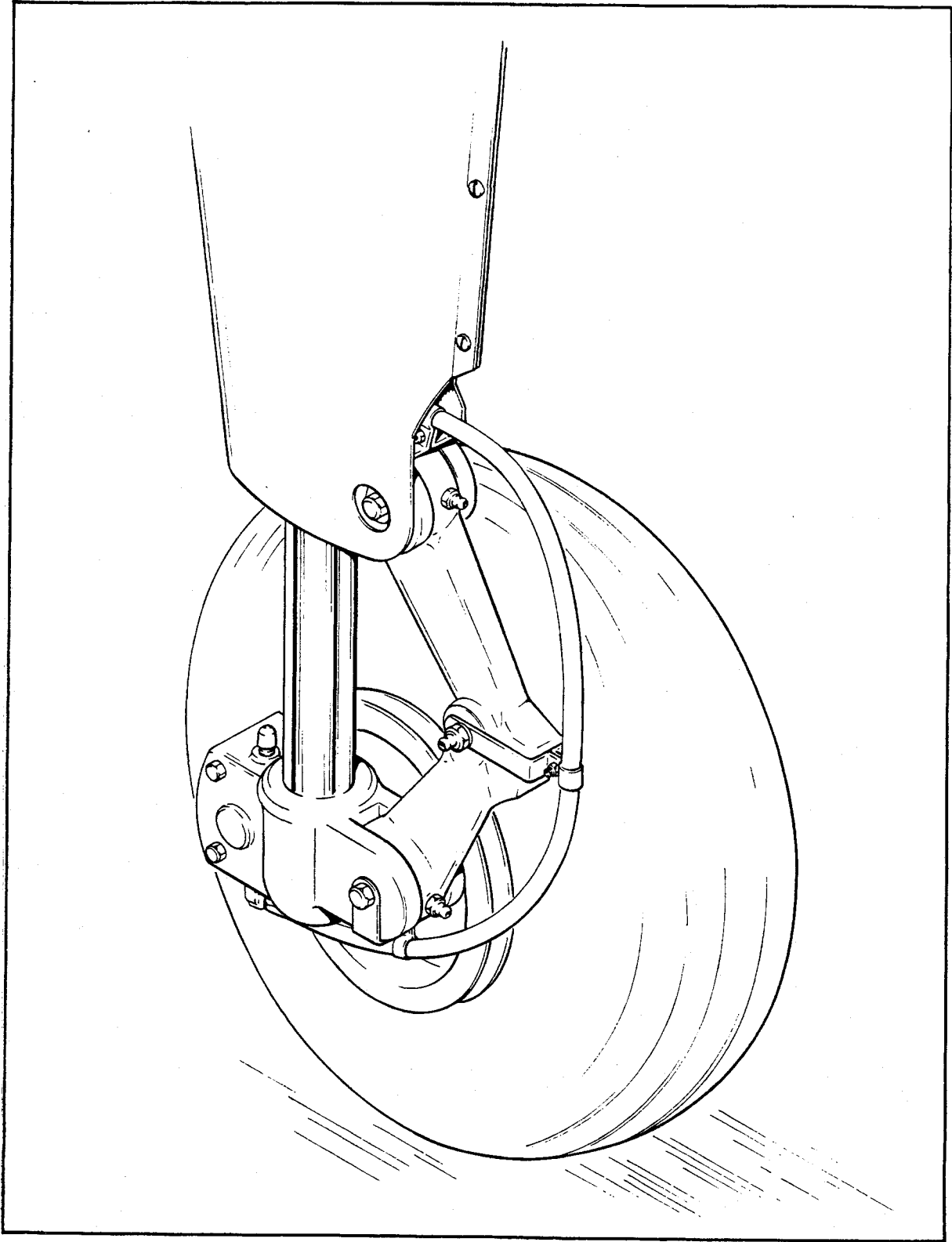

Main Wheel Assembly

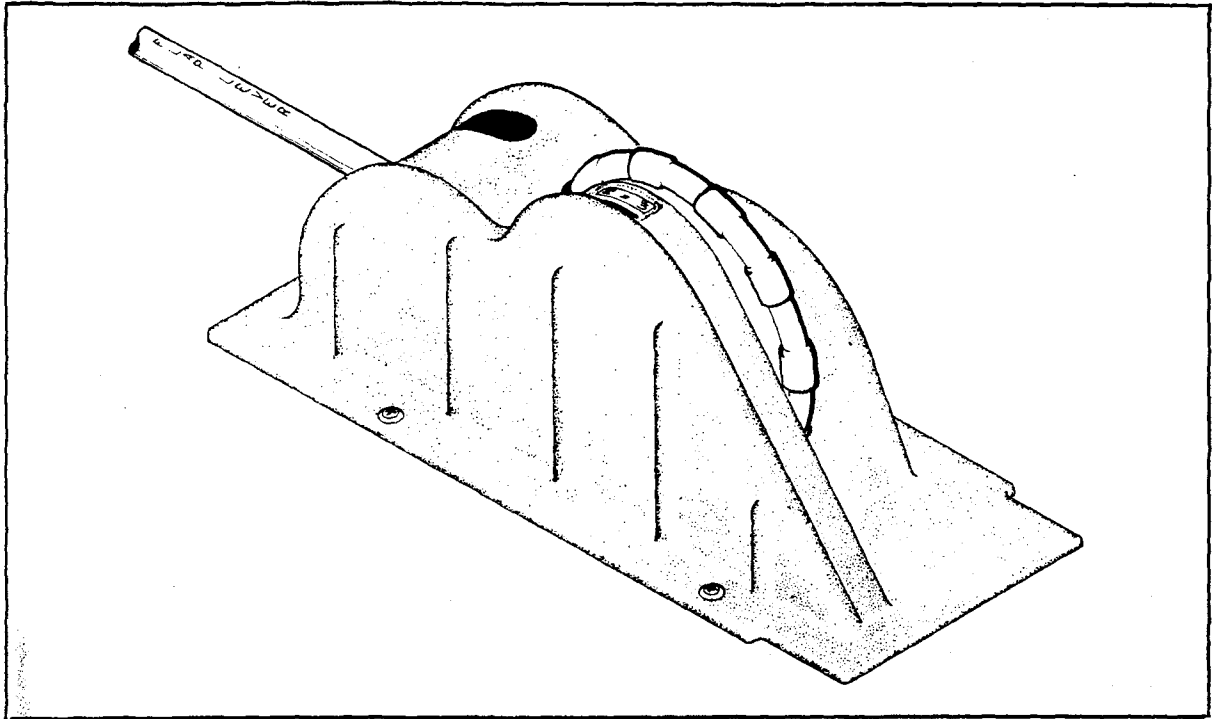

Console

FLIGHT CONTROLS

Dual controls, with a cable system between the controls and the surfaces, are installed as standard equipment.

The horizontal tail is of the all-movable slab type (**stabilator**). The stabilator provides extra stability and controllability with less size, drag, and weight than conventional tail surfaces.

An **anti-servo tab** which also acts as a longitudinal trim tab, is located on the horizontal tail. This tail is actuated by a control mounted on the control tunnel between the front seats.

The ailerons are provided with a differential action which tends to eliminate adverse yaw in turning maneuvers and to reduce the amount of coordination required in normal turns.

The flaps are manually operated, balanced for light operating forces, and spring-loaded to return to the up position. A past-center lock incorporated in the actuating linkage holds the flap when it is in the up position so that it may be used as a step on the right side. Since the flap will not support a step load except in the full up position, it should be completely retracted when the airplane is on the ground. The flaps have three extended positions, 10, 25, and 40 degrees.

FUEL SYSTEM

The standard fuel capacity of the Cherokee Six is 84 gallons, all of which is usable except for approximately one pint in each of the four tanks. The **two main inboard tanks**, which hold 25 gallons each, are attached to the wing structure with screws and nut plates and can be removed easily for service or inspection. The **tip tanks** are constructed of resin-impregnated fiberglass, and each one holds 17 gallons.

When using less than the standard 84 gallon capacity of the tanks, fuel should be distributed equally between each side. The tip tanks should always be filled first, and fuel from the main tanks should be used first. All weight in excess of 3112 pounds must be in fuel weight only.

The **fuel selector control** is located below the center of the instrument panel on the sloping face of the control tunnel. It has five positions, one position corresponding to each of the four tanks plus an OFF position.

To avoid the accumulation of water and sediment, the fuel system should be drained daily prior to first flight and after refueling. Each tank is equipped with an **individual quick drain** located at the lower inboard rear corner of the tank. The **fuel strainer** and a **system quick drain valve** are located in the fuselage at the lowest point of the fuel system. It is important that the fuel system be drained in the following manner:

1. Drain each tank through its individual quick drain located at the lower inboard rear corner of the tank, making sure that enough fuel has flowed to ensure the removal of all water and sediment.
2. Place a container beneath the fuel sump drain outlet located under the fuselage. A special container is furnished for this operation.
3. Drain the fuel strainer by pressing down on the lever located on the right side of the cabin on the forward edge of the wing spar housing. Move the selector through the following sequence: OFF position, left tip, left main, right main, and right tip while draining the strainer. Make sure that enough fuel has flowed to drain the fuel line between each tank outlet and the fuel strainer, as well as the strainer itself. With full fuel tanks, it will take approximately 11 seconds to drain all the fuel in one of the fuel lines from the tip tank to the strainer, and approximately 6 seconds to drain all of the fuel from the line from either main tank to the fuel strainer. When the tanks are less than full, it will take a few seconds longer.
4. Examine the contents of the container placed under the fuel sump drain outlet. When the fuel flow is free of water and sediment, close the drain and dispose of the contents of the bottle.

CAUTION

When draining fuel, care should be taken to ensure that no fire hazard exists before starting the engine.

After using the underseat quick drain, check from the outside to make sure that it has closed completely and is not leaking.

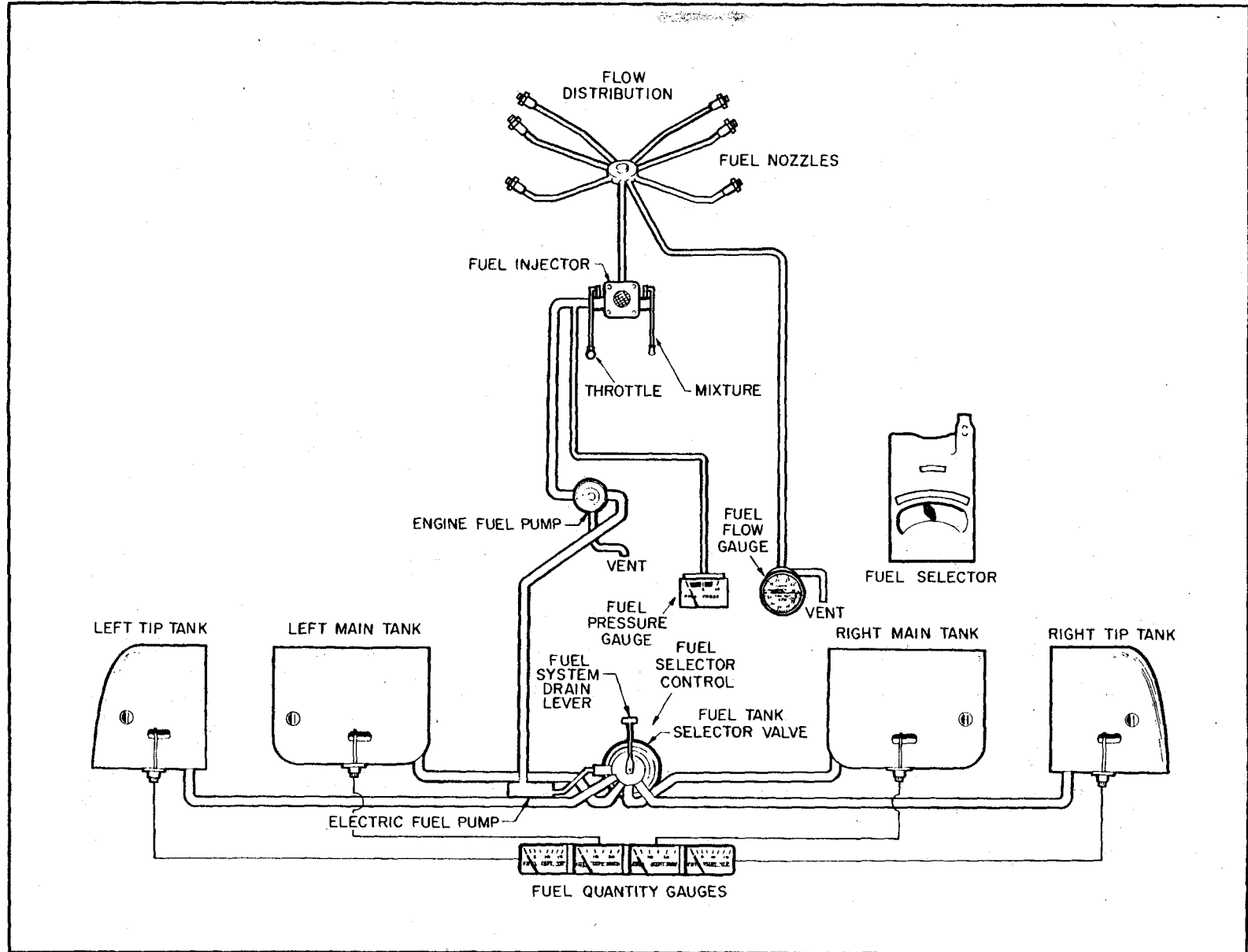

Fuel System Schematic

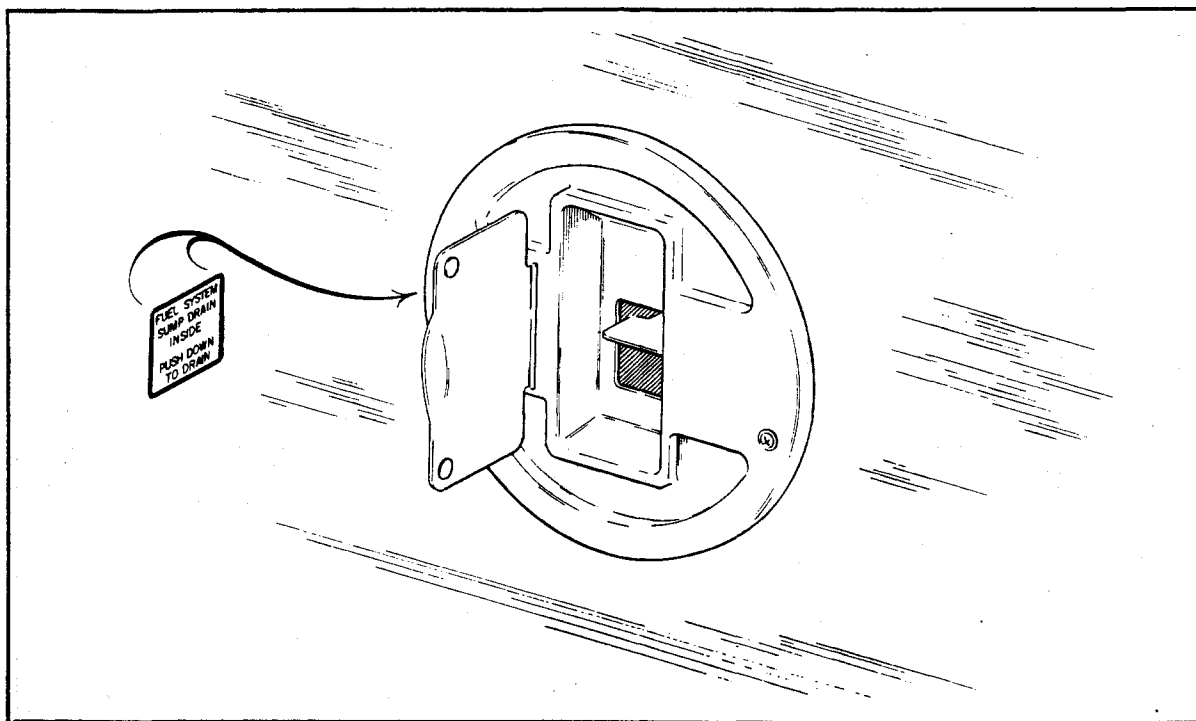

Fuel Drain Lever

Fuel quantity gauges for each of the four tanks are located in the engine gauge cluster on the left side of the instrument panel. A **fuel pressure indicator** is also incorporated in the engine gauge cluster.

An **electric fuel pump** is provided for use in case of failure of the engine driven pump. The electric pump operates from a single switch and independent circuit protector. It should be ON for all takeoffs and landings.

ELECTRICAL SYSTEM

The 14-volt electrical system includes a 12-volt **battery** for starting and to back up alternator output. Electrical power is supplied by a 60 ampere **alternator**. The battery, a master switch relay, a voltage regulator and an overvoltage relay are located beneath the floor of the forward baggage compartment, and access is obtained by removing the floor.

Electrical switches are located on a panel to the pilot's left and all **circuit breakers** are on the lower right instrument panel behind a decorative door. Two thumb-wheel rheostat switches to the left of the circuit breakers control the navigation lights and the intensity of the instrument panel lights.

CHEROKEE SIX-300

Standard **electrical accessories** include the starter, the electric fuel pump, the stall warning indicator, the cigar lighter, the ammeter, and the annunciator panel*.

The annunciator panel* includes alternator and low oil pressure indicator lights. When the optional gyro system is installed, the annunciator panel also includes a low vacuum indicator light. The annunciator panel lights are provided only as a warning to the pilot that a system may not be operating properly, and that he should check and monitor the applicable system gauge to determine when or if any necessary action is required.

Optional electrical accessories include the navigation lights, an anti-collision light, and instrument panel lighting.

Circuit provisions are made to handle a full complement of communications and navigational equipment.

The **alternator system** offers many advantages over a generator system. The main advantage is full electrical power output at much lower engine speed, which results in improved radio and electrical equipment operation. Since the alternator output is available all the time, the battery will be charging almost continuously. This will make cold weather starting easier.

The **ammeter** in the alternator system displays in amperes the load placed on the alternator. It does not indicate battery discharge. With all electrical equipment off (except the master switch) the ammeter will be indicating the amount of charging current demanded by the battery. As each item of electrical equipment is turned on, the current will increase to a total appearing on the ammeter. This total includes the battery. The maximum continuous load for night flight, with radios on, is about 30 amperes. This 30 ampere value, plus approximately 2 amperes for a fully charged battery, will appear continuously under these flight conditions.

The **master switch** is a split switch with the left half operating the master relay and the right half energizing the alternator. This switch is interlocked so that the alternator cannot be operated without the battery. For normal operation, be sure that both halves are turned on.

If no output is indicated by the ammeter during flight, reduce the electrical load by turning off all unnecessary electrical equipment. Check both the 5 ampere field breaker and the 60 ampere output breaker and reset if open. If neither circuit breaker is open, turn off the alternator switch for 1 second to reset the overvoltage relay. If the ammeter continues to indicate no output, turn off the alternator switch; maintain a minimum electrical load; and terminate the flight as soon as practical.

Maintenance on the alternator should prove to be a minor factor. Should service be required, contact a Piper Dealer.

*Serial nos. 7540001 and up

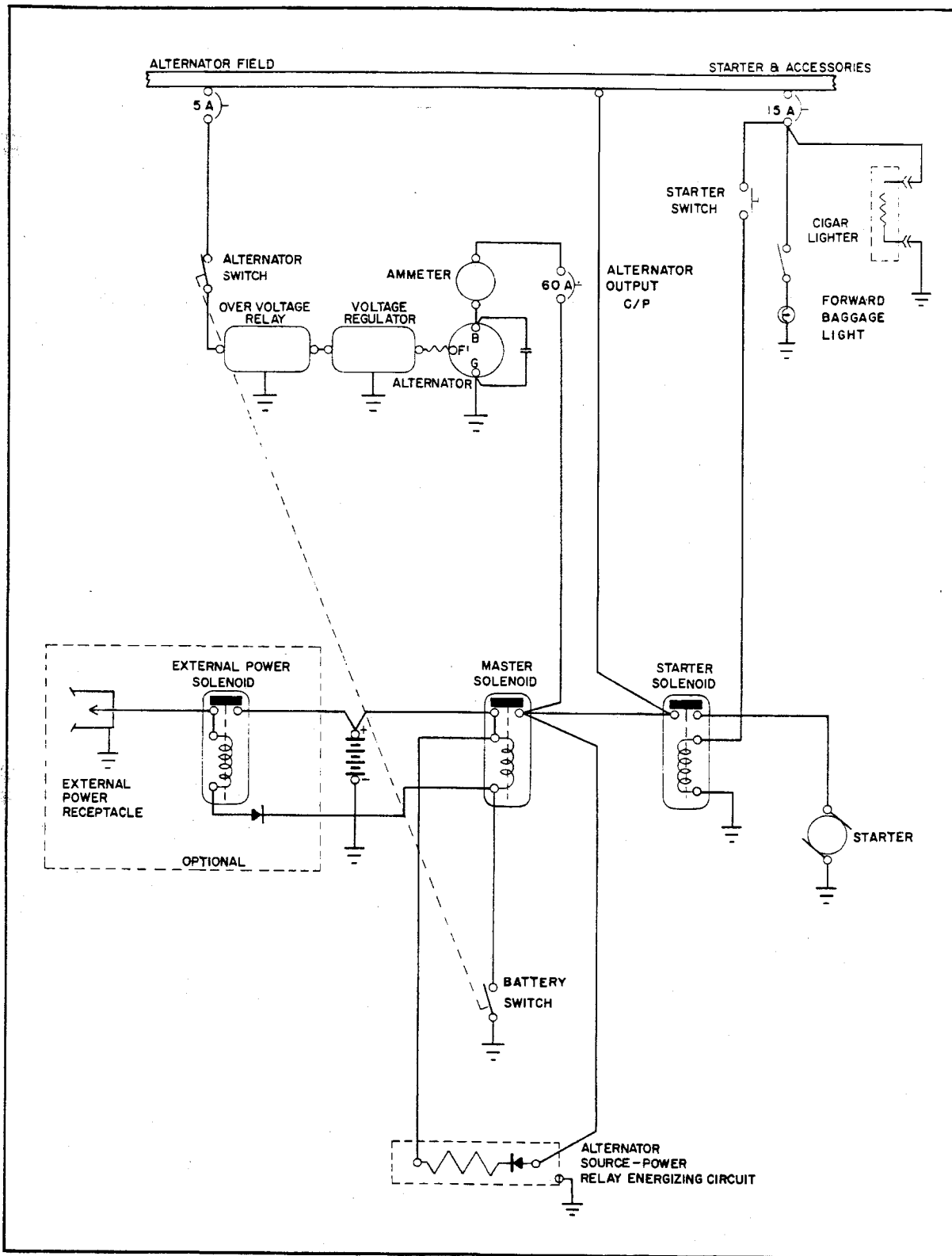

Alternator and Starter Schematic (Ser. Nos. 7440001 through 7440182)

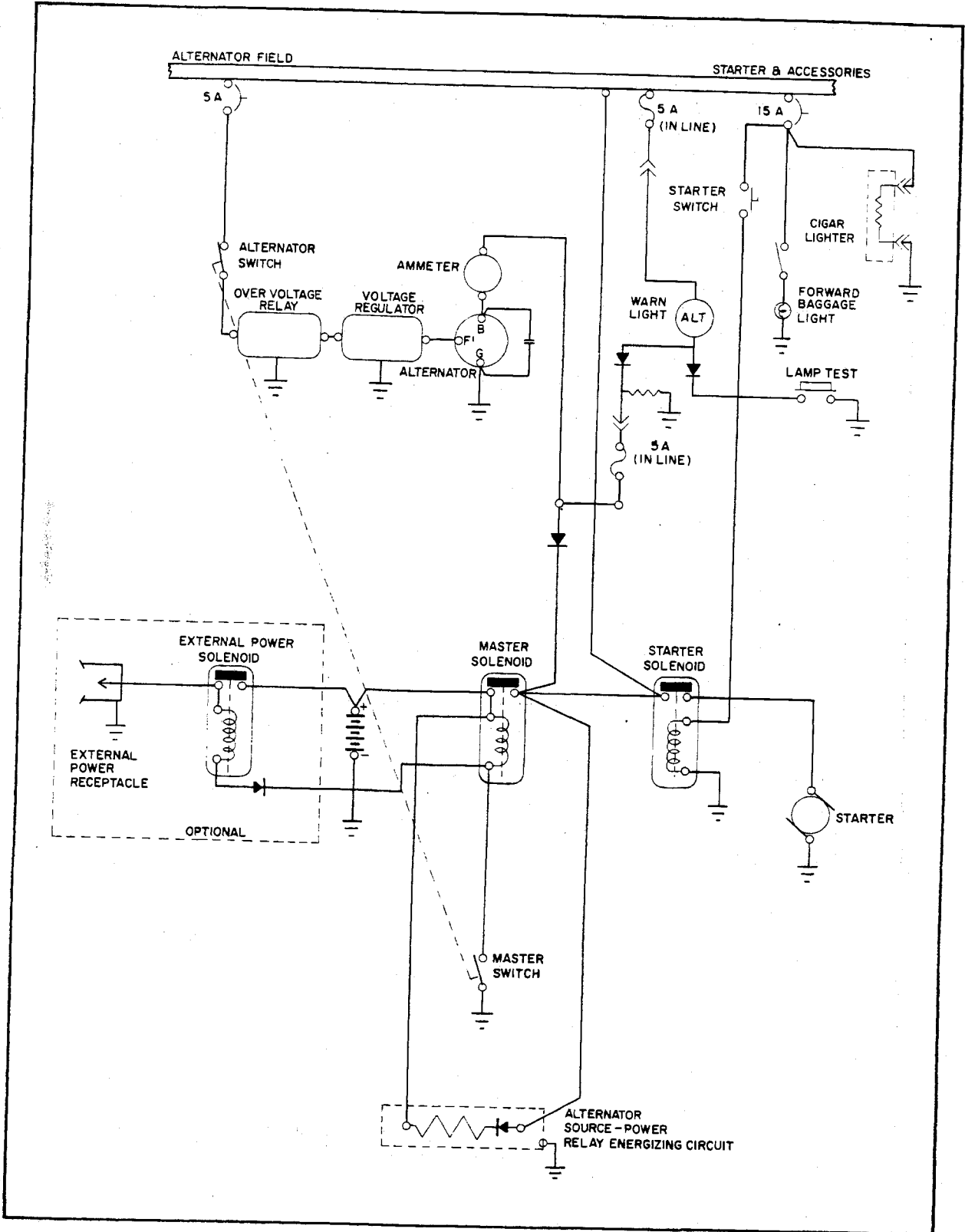

Alternator and Starter Schematic (Ser. Nos. 7540001 and up)

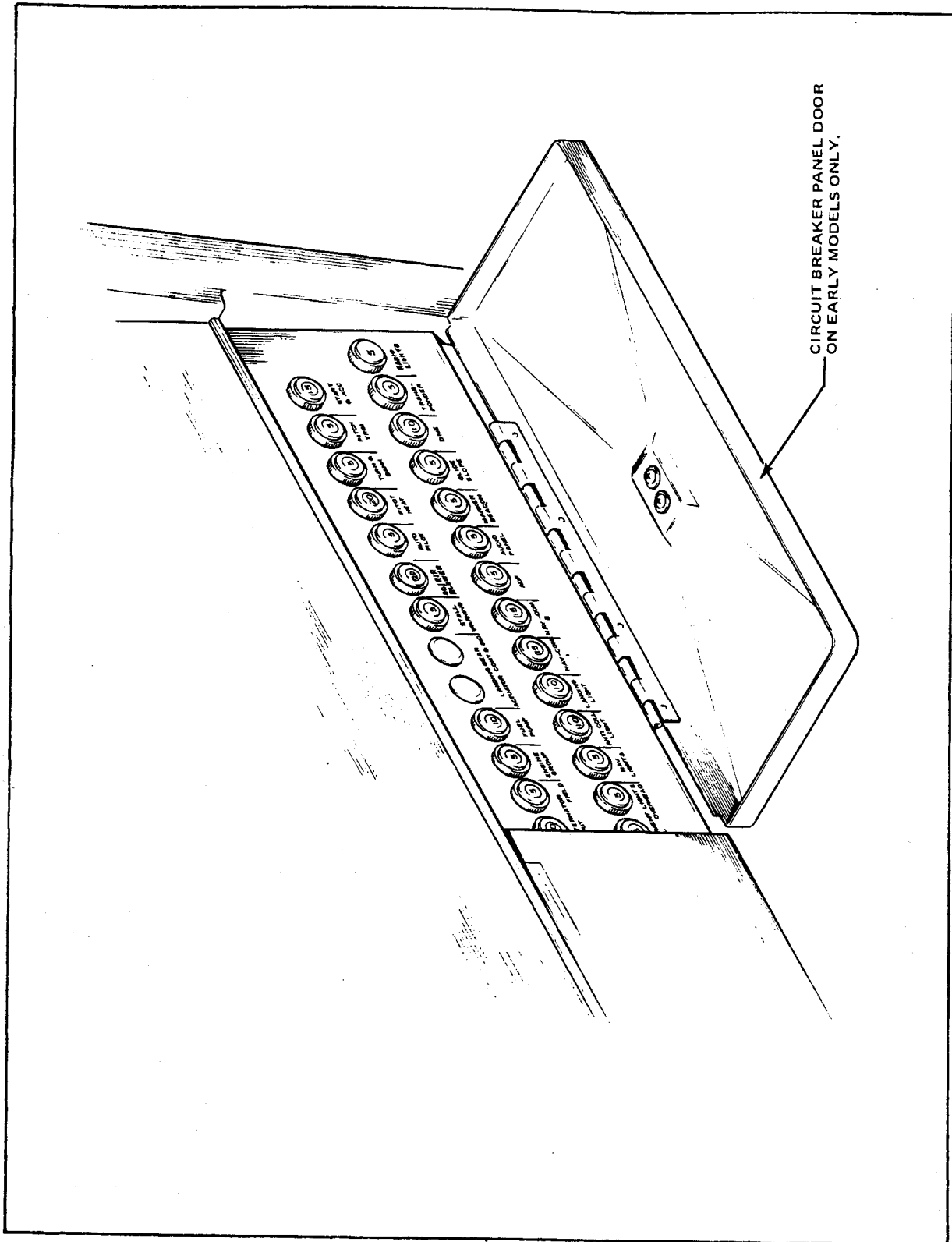

Circuit Breaker Panel

VACUUM SYSTEM

The vacuum system employed to operate the gyro instruments includes an engine-driven dry vacuum pump, a vacuum regulator valve, and the tubing necessary to complete the system.

The use of a dry type vacuum pump eliminates the need for an oil-air separator and the hardware necessary for its installation.

The vacuum gauge is mounted on the right side of the instrument panel. The gauge is calibrated in inches of mercury and indicates the amount of suction created by the engine-driven vacuum pump. As the system filter becomes clogged or the lines obstructed, the gauge will show a decrease in pressure (a low vacuum indicator light is provided in the annunciator panel*). Do not reset the regulator until the filter and lines have been checked.

A vacuum regulator valve is incorporated in the system to control vacuum pressure to the gyro instruments. The regulator valve is located under the instrument panel. Access to the valve for maintenance and adjustment is gained from below the instrument panel. The regulator should be set so that the vacuum gauge reads $5.0 \pm .1$ inches of mercury with the engine running at medium RPM after warm-up.

INSTRUMENT PANEL

The instrument panel of the Cherokee Six is designed to accommodate the customary advanced flight instruments and the normally required power plant instruments. The artificial horizon and directional gyro are vacuum operated and are located in the center of the left hand instrument panel. The vacuum gauge is located on the right hand instrument panel. The turn indicator, on the left side, is electrically operated.

A natural separation of the flight group and the power group is achieved by the placement of the flight group in the upper instrument panel and the power group in the center and lower instrument panels. The radios are located in the center section of the panel, and the circuit breakers are in the lower right behind a decorative door.

An annunciator panel* is mounted in the upper instrument panel to warn the pilot of a possible malfunction in the alternator, oil pressure, or vacuum systems.

*Serial nos. 7540001 and up

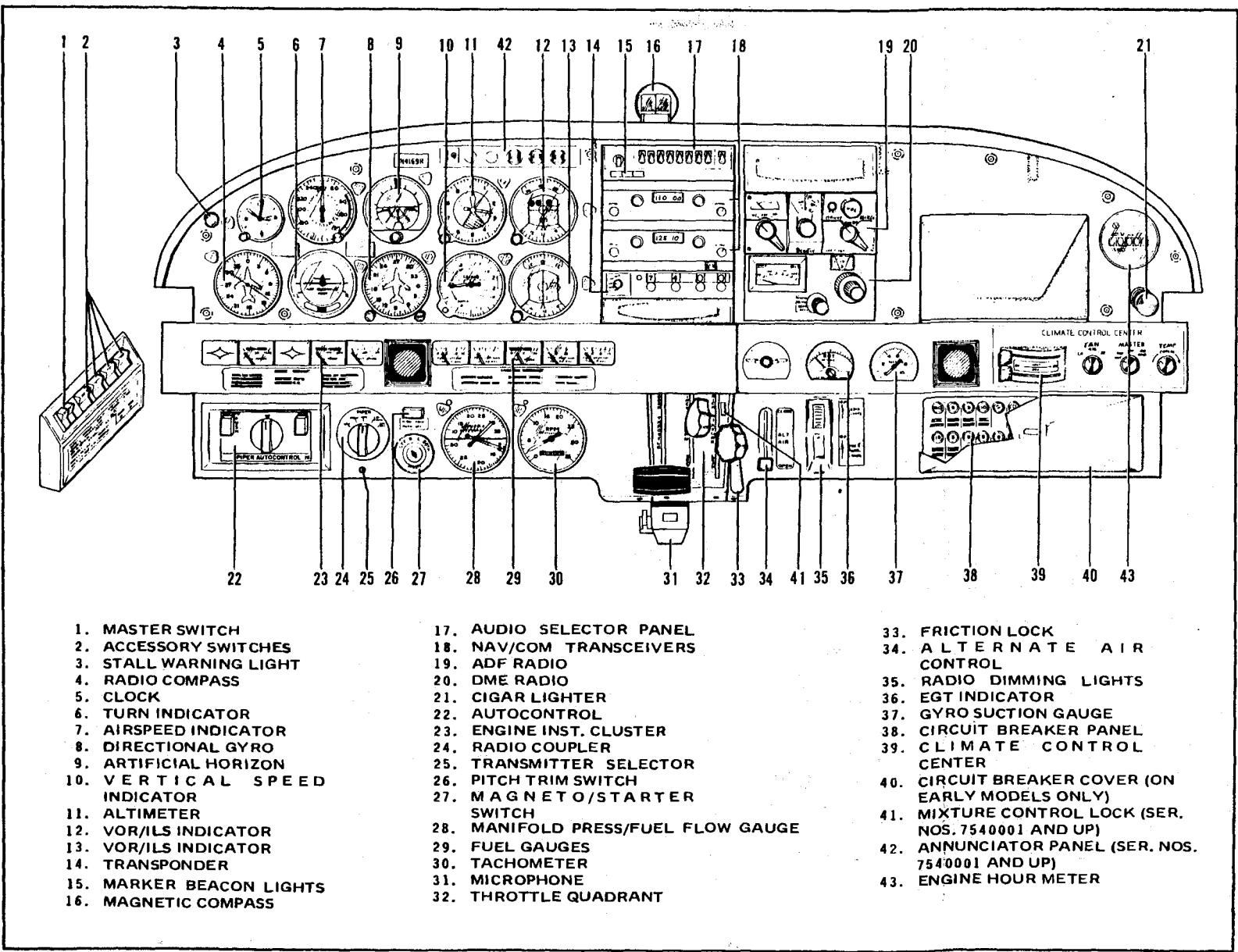

Instrument Panel

- | | | |
|---|--|--|
| <ul style="list-style-type: none"> 1. MASTER SWITCH 2. ACCESSORY SWITCHES 3. STALL WARNING LIGHT 4. RADIO COMPASS 5. CLOCK 6. TURN INDICATOR 7. AIRSPEED INDICATOR 8. DIRECTIONAL GYRO 9. ARTIFICIAL HORIZON 10. VERTICAL SPEED INDICATOR 11. ALTIMETER 12. VOR/ILS INDICATOR 13. VOR/ILS INDICATOR 14. TRANSPONDER 15. MARKER BEACON LIGHTS 16. MAGNETIC COMPASS | <ul style="list-style-type: none"> 17. AUDIO SELECTOR PANEL 18. NAV/COM TRANSCEIVERS 19. ADF RADIO 20. DME RADIO 21. CIGAR LIGHTER 22. AUTOCONTROL 23. ENGINE INST. CLUSTER 24. RADIO COUPLER 25. TRANSMITTER SELECTOR 26. PITCH TRIM SWITCH 27. MAGNETO/STARTER SWITCH 28. MANIFOLD PRESS/FUEL FLOW GAUGE 29. FUEL GAUGES 30. TACHOMETER 31. MICROPHONE 32. THROTTLE QUADRANT | <ul style="list-style-type: none"> 33. FRICTION LOCK 34. ALTERNATE AIR CONTROL 35. RADIO DIMMING LIGHTS 36. EGT INDICATOR 37. GYRO SUCTION GAUGE 38. CIRCUIT BREAKER PANEL 39. CLIMATE CONTROL CENTER 40. CIRCUIT BREAKER COVER (ON EARLY MODELS ONLY) 41. MIXTURE CONTROL LOCK (SER. NOS. 7540001 AND UP) 42. ANNUNCIATOR PANEL (SER. NOS. 7540001 AND UP) 43. ENGINE HOUR METER |
|---|--|--|

PITOT-STATIC SYSTEM

The system supplies both **pitot** and **static** pressure for the airspeed indicator, altimeter and vertical speed indicator (when installed).

Pitot and static pressure are picked up by the pitot head on the bottom of the left wing. An optional heated pitot head, which alleviates problems with icing or heavy rain, is available. The switch for pitot heat is located on the lower left instrument panel.

To prevent bugs and water from entering the pitot and static pressure holes when the airplane is parked, a cover should be placed over the pitot head. A partially or completely blocked pitot head will give erratic or zero readings on the instruments.

NOTE

During preflight, check to make sure the pitot cover is removed.

HEATING AND VENTILATING SYSTEM

Heat for the cabin interior and the defroster system is drawn from a heater muff attached to the exhaust system. Controls for these systems are located on the lower right side of the instrument panel.

NOTE

If unusual odors are detected, turn off the heat and inspect the system for leaks.

Fresh air inlets are located in the leading edge of each wing at the intersection of the tapered and straight sections, and in the leading edge of the fin. Two large adjustable outlets are located on each side of the cabin, one forward and one aft of the front seat near the floor. There are also adjustable outlets above each seat. In airplanes without air conditioning, an optional blower may be added to the overhead vent system to aid in the circulation of cabin air.

CABIN FEATURES

For ease of entry and exit and for pilot and passenger comfort, the front seats are adjustable fore and aft. All seats recline and have armrests and are available with optional headrests. The front seats can be equipped with optional vertical adjustment. The center and rear seats are easily removed for additional cargo space. Some rear seat installations incorporate leg retainers with latching mechanisms which must be released before the rear seats can be removed. Releasing the retainers is easily accomplished by turning the latching mechanisms 90° with a coin or screwdriver. An optional jump seat can be installed between the two middle seats to give the airplane a seven-place capacity.

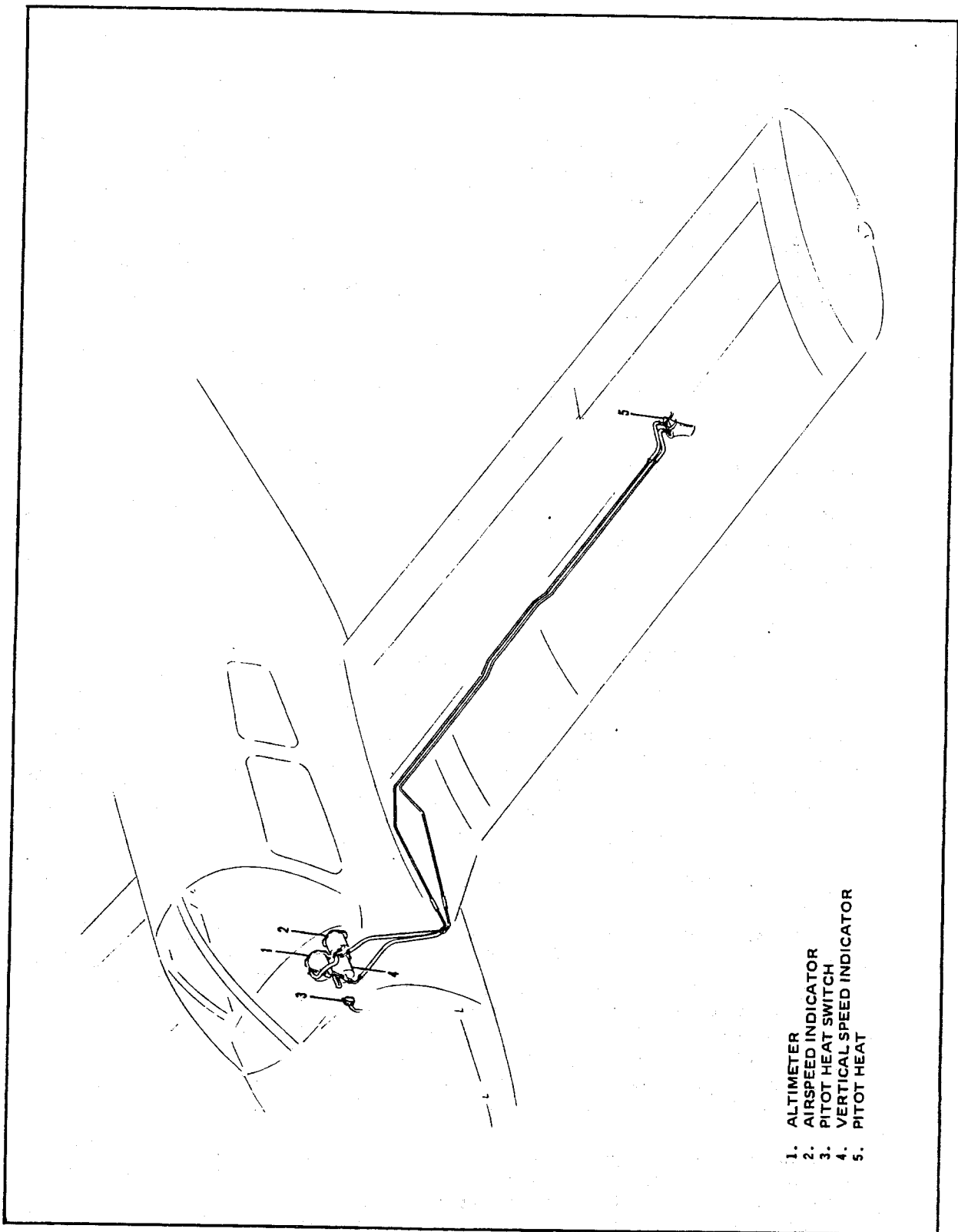

Single strap **shoulder harnesses** controlled by **inertia reels** are standard equipment for the front seats and are offered as optional equipment for the third, fourth, fifth and sixth seats, but not for the seventh seat. The **shoulder strap** is routed over the shoulder adjacent to the windows and attached to the lap belt in the general area of the person's inboard hip.



Pitot-Static System

Heating and Ventilating System

- 1. FRESH AIR INLET
- 2. DRAIN TUBE
- 3. OVERHEAD VENT BLOWER
- 4. BULKHEAD ASSEMBLY
- 5. OVERHEAD FRESH AIR DUCT
- 6. CABIN AIR EXHAUST
- 7. FRESH AIR OUTLET
- 8. DEFROSTER OUTLET
- 9. CABIN HEAT OUTLET
- 10. DEFROSTER AIR CONTROL
- 11. HEATER AIR CONTROL

-  FRESH AIR
-  DEFROSTER AIR
-  HEATED AIR

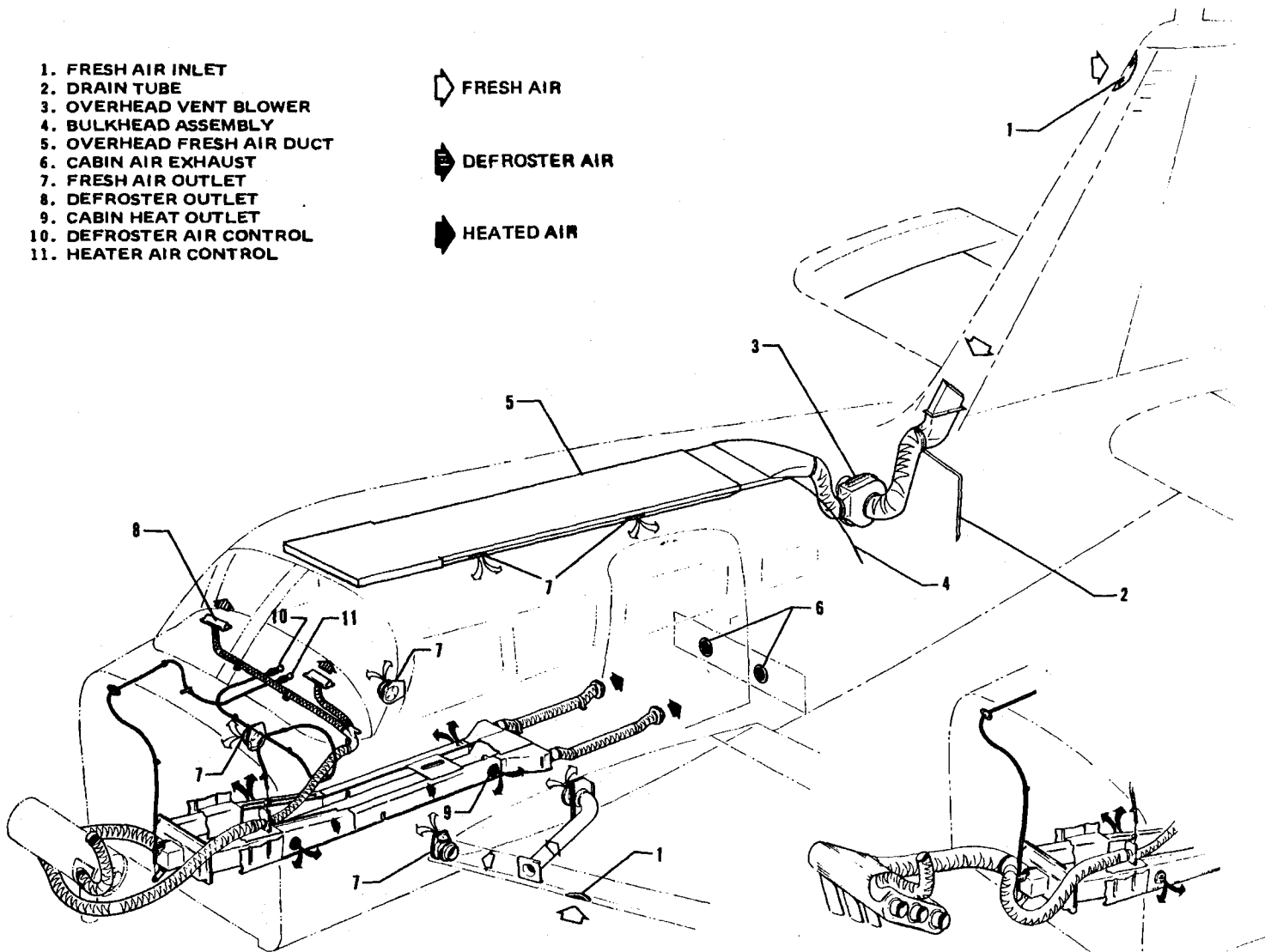

SERIAL NOS. 7544001 THROUGH 7540188

SERIAL NOS. 7640001 AND UP

The inertia reel should be checked by tugging sharply on the strap. The reel will lock in place under this test and prevent the strap from extending. Under normal movement, the strap will extend and retract as required.

BAGGAGE AREA

The airplane has two separate baggage areas, each with a 100 pound capacity. An 8 cubic foot forward luggage compartment, located just aft of the fire wall, is accessible through a 16 x 22 inch door on the right side of the fuselage. A 22 cubic foot aft compartment is located behind the fifth and sixth seats and is conveniently accessible even during flight from inside the cabin.

NOTE

It is the pilot's responsibility to be sure when the baggage is loaded that the airplane's C.G. falls within the allowable C.G. range. (See Weight and Balance Section.)

STALL WARNING

An approaching stall is indicated by a stall warning indicator which is activated between five and ten miles per hour above stall speed. Mild airframe buffeting and gentle pitching may also precede the stall. Stall speeds are shown on graphs in the Performance Charts Section. The stall warning indicator is a red warning light on the left side of the instrument panel on earlier models and a continuous sounding horn located behind the instrument panel on later models. The stall warning indicator is activated by a lift detector installed on the leading edge of the left wing. During preflight, the stall warning system should be checked by turning the master switch "ON," lifting the detector and checking to determine if the indicator is actuated.

FINISH

All exterior surfaces are primed with etching primer and finished with acrylic lacquer available in a variety of colors and combinations. To keep the finish attractive looking, economy size spray cans of touch-up paint are available from Piper Dealers.

AIR CONDITIONING*

The air conditioning system is a recirculating air system. The major components include an evaporator, a condenser, a compressor, a blower, switches and temperature controls.

The evaporator is located behind the rear baggage compartment. This cools the air used for the air conditioning system.

The condenser is mounted on a retractable scoop located on the bottom of the fuselage and to the rear of the baggage compartment area. The scoop extends when the air conditioner is ON and retracts to a flush position when the system is OFF.

The compressor is mounted on the forward right underside of the engine. It has an electric clutch which automatically engages or disengages the compressor to the belt drive system of the compressor.

*Optional equipment

An **optional electric blower** is mounted on the aft side of the rear cabin panel. Air from the baggage area is drawn through the evaporator by the blower and distributed through an overhead duct to individual outlets located adjacent to each occupant.

The switches and temperature control are located on the lower right side of the instrument panel in the climate control center panel. The **temperature control** regulates the temperature of the cabin. Turning the control clockwise increases cooling; counterclockwise decreases cooling.

The **fan speed switch** and the **air conditioning ON-OFF switch** are inboard of the temperature control. The fan can be operated independently of the air conditioning; however, the fan must be on for air conditioner operation. Turning either switch off will disengage the compressor clutch and retract the condenser door. Cooling air should be felt within one minute after the air conditioner is turned on.

NOTE

If the system is not operating in 5 minutes, turn the system OFF until the fault is corrected.

The **fan switch** allows operation of the fan with the air conditioner turned OFF to aid in cabin air circulation. "LOW," "MED" or "HIGH" can be selected to direct a flow of air through the air conditioner outlets in the overhead duct. These outlets can be adjusted or turned off individually.

The **condenser door light** is located to the right of the engine instrument cluster in front of the pilot. The door light illuminates when the door is open and is off when the door is closed.

A circuit breaker on the circuit breaker panel protects the air conditioning electrical system.

Whenever the throttle is in the full forward position, it actuates a micro switch which disengages the compressor and retracts the scoop. This allows maximum power and maximum rate of climb. The fan continues to operate and the air will remain cool for about one minute. When the throttle is retarded approximately 1/4 inch, the clutch will engage, the scoop will extend, and the system will again supply cool, dry air.

PIPER EXTERNAL POWER*

An optional starting installation known as Piper External Power (PEP) is accessible through a receptacle located on the left side of the nose section aft of the cowling. An external battery can be connected to the socket, thus allowing the operator to crank the engine without having to gain access to the airplane's battery.

*Optional equipment

**F.A.A. APPROVED
EMERGENCY PROCEDURES**

NONE APPLICABLE TO THIS AIRPLANE

AIRPLANE FLIGHT MANUAL

FOR

CHEROKEE SIX 300

APPLICABLE TO SERIAL NUMBERS 32-7440001 THROUGH 32-7640130

**REPORT: VB-562
MODEL: PA-32-300**

AIRPLANE FLIGHT MANUAL

Log of Revisions	3-iii
Limitations	3-1
Procedures	3-7
Performance	3-9
Supplements	3-11

TABLE OF CONTENTS

Log of Revisions	3-iii
SECTION I	
Limitations	3-1
A. Engine	3-1
B. Fuel	3-1
C. Propeller	3-1
D. Power Instruments	3-1
E. Airspeed Limitations and Airspeed Instrument Markings (Calibrated Airspeed)	3-2
F. Maximum Weight	3-2
G. C. G. Range	3-2
H. Maneuvers	3-2
I. Placards	3-3
J. Rear Cabin Door or Rear Cabin Door and Cargo Door Removed	3-5
K. Seven-Passenger Operation	3-5
L. Nose Wheel Fairing Removed	3-5
SECTION II	
Procedures	3-7
SECTION III	
Performance	3-9
SECTION IV	
Optional Equipment	3-11
A. Electric Pitch Trim Installation	3-13
B. AutoFlite II Installation	3-16
C. Air Conditioner Installation	3-17
D. Piper AutoControl III and/or AutoControl IIIB Installation	3-19
E. Piper AltiMatic IIIC Installation	3-23

SECTION I

LIMITATIONS

The following limitations must be observed in the operation of this airplane:

A. ENGINE

Lycoming IO-540-K1A5 (Serial nos. 7440001 through 7640065 and 7640067 through 7640071)

Lycoming IO-540-K1G5 (Serial nos. 7640066, 7640072 and up)

ENGINE LIMITS

For all operations 2700 RPM, 300 HP

B. FUEL

100/130 minimum aviation grade fuel

C. PROPELLER

Hartzell HC-C2YK-1/8475D-4 or HC-C2YK-1()/8475-4 or HC-C2YK-1()F/F8475D-4

Low pitch stop $13.5^{\circ} \pm .2^{\circ}$, high pitch stop $34^{\circ} \pm 1^{\circ}$

Maximum diameter 80 inches, minimum diameter 78.5 inches

OPTIONAL PROPELLER (Ser. nos. 7440001 through 7540188 only)

Hartzell HC-C2YK-1()/8475R-0 or HC-C2YK-1()F/F8475R-0

Low pitch stop $12.4^{\circ} \pm .2^{\circ}$, high pitch stop $29^{\circ} \pm 1^{\circ}$

Maximum diameter 84 inches, minimum diameter 82.3 inches

D. POWER INSTRUMENTS

OIL TEMPERATURE

Green Arc (Normal Operating Range)

75° F to 245° F

Red Line (Maximum)

245° F

OIL PRESSURE

Green Arc (Normal Operating Range)

60 PSI to 90 PSI

Yellow Arc (Caution Range)

25 PSI to 60 PSI

Red Line (Minimum)

25 PSI

Red Line (Maximum)

90 PSI

FUEL PRESSURE

Green Arc (Normal Operating Range)

18 PSI to 40 PSI

Red Line (Minimum)

18 PSI

Red Line (Maximum)

40 PSI

Yellow Arc (Idle Range)

12 PSI to 18 PSI

TACHOMETER

Green Arc (Normal Operating Range)

500 to 2700 RPM

Red Line (Maximum Continuous Power)

2700 RPM

CHEROKEE SIX-300

E. AIRSPEED LIMITATIONS AND AIRSPEED INSTRUMENT MARKINGS (Calibrated Airspeed)

NEVER EXCEED	212 MPH
MAXIMUM STRUCTURAL CRUISE	168 MPH
MANEUVERING	149 MPH
FLAPS EXTENDED	125 MPH
MAXIMUM POSITIVE LOAD FACTOR	3.8
MAXIMUM NEGATIVE LOAD FACTOR	No inverted maneuvers approved

AIRSPEED INSTRUMENT MARKINGS

Red Radial Line (Never Exceed)	212 MPH (184 KTS)
Yellow Arc (Caution Range) (Smooth Air Only)	168 MPH to 212 MPH (146 KTS to 184 KTS)
Green Arc (Normal Operating Range)	71 MPH to 168 MPH (62 KTS to 146 KTS)
White Arc (Flap Down)	63 MPH to 125 MPH (55 KTS to 109 KTS)

F. MAXIMUM WEIGHT 3400 LBS

G. C. G. RANGE

The datum used is 78.4 inches ahead of the wing leading edge at the intersection of the straight and tapered section.

<u>Weight (Pounds)</u>	<u>Forward Limit (In. Aft of Datum)</u>	<u>Rearward Limit (In. Aft of Datum)</u>
3400	91.4	95.5
3300	89.0	96.2
2900	80.0	96.2
2400	76.0	96.2

Straight line variation between points given.

NOTE

It is the responsibility of the airplane owner and the pilot to insure that the airplane is properly loaded. See Weight and Balance Section for proper loading instructions.

H. MANEUVERS

No acrobatic maneuvers including spins approved.

I. PLACARDS

In full view of the pilot:

“THIS AIRPLANE MUST BE OPERATED AS A NORMAL CATEGORY AIRPLANE IN COMPLIANCE WITH THE OPERATING LIMITATIONS STATED IN THE FORM OF PLACARDS, MARKINGS AND MANUALS. NO ACROBATIC MANEUVERS, INCLUDING SPINS, APPROVED.”

“THIS AIRCRAFT APPROVED FOR NIGHT IFR NON-ICING FLIGHT WHEN EQUIPPED IN ACCORDANCE WITH FAR 91 OR FAR 135.”

In full view of the pilot, the following takeoff and landing check lists will be installed:

TAKEOFF CHECK LIST

Fuel on proper tank	Mixture set	Flaps 10° (1st notch)
Electric fuel pump on	Propeller set	Trim tab - set
Engine gauges checked	Fasten belts/harness	Controls free
Alternate air closed		Doors latched
Seat backs erect		Air Conditioner - Off

LANDING CHECK LIST

Seat backs erect	Fuel on proper tank	Mixture rich
Fasten belts/harness	Electric fuel pump on	Propeller set
Air Conditioner - Off		Flaps down (125 mph)

The “AIR CONDITIONER OFF” item in the above takeoff and landing check lists is mandatory for air conditioned aircraft only.

On the instrument panel in full view of the pilot:

“ROUGH AIR OR MANEUVERING SPEED 149 MPH.”

On the instrument panel in full view of the pilot:

“DEMONSTRATED CROSSWIND COMPONENT 20 MPH.”

In full view of the pilot: (For operation with the rear door removed)

“FOR FLIGHT WITH THE DOOR REMOVED, SEE THE LIMITATIONS AND PROCEDURES SECTIONS OF THE AIRPLANE FLIGHT MANUAL.”

On the instrument panel in full view of the pilot when the AutoFlite is installed:

“FOR HEADING CHANGES: PRESS DISENGAGE SWITCH ON CONTROL WHEEL. CHANGE HEADING. RELEASE DISENGAGE SWITCH.”

On the fuel selector valve cover:

“ALL WEIGHT IN EXCESS OF 3112 POUNDS MUST BE FUEL WEIGHT ONLY. FILL TIP TANKS FIRST. USE MAIN TANKS FIRST.”

On the instrument panel in full view of the pilot when the AutoFlite II is installed:

“TURN AUTOFLITE ON. ADJUST TRIM KNOB FOR MINIMUM HEADING CHANGE: FOR HEADING CHANGE, PRESS DISENGAGE SWITCH ON CONTROL WHEEL, CHANGE HEADING, RELEASE SWITCH. ROTATE TURN KNOB FOR TURN COMMANDS. PUSH TURN KNOB IN TO ENGAGE TRACKER. PUSH TRIM KNOB IN FOR HI SENSITIVITY. LIMITATIONS AUTOFLITE OFF FOR TAKEOFF AND LANDING.”

On the instrument panel in full view of the pilot when the supplementary white strobe lights are installed:

“WARNING - TURN OFF STROBE LIGHTS WHEN TAXIING IN VICINITY OF OTHER AIRCRAFT, OR DURING FLIGHT THROUGH CLOUD, FOG OR HAZE.”

In full view of the pilot, in the area of the air conditioner controls when the air conditioner is installed:

“WARNING - AIR CONDITIONER MUST BE OFF TO INSURE NORMAL TAKEOFF CLIMB PERFORMANCE.”

J. REAR CABIN DOOR OR REAR CABIN DOOR AND CARGO DOOR REMOVED

The following limitations must be observed in the operation of this airplane with the rear cabin door or rear cabin door and cargo door removed:

1. The airplane may be flown with the rear cabin door or rear cabin door and cargo door removed. Flight with the front door removed is not approved.
2. Maximum speed - 165 mph.
3. No smoking.
4. All loose articles must be tied down and stowed.
5. Jumper's static lines must be kept free of pilot's controls and control surfaces.
6. Operation approved VFR flight conditions only.

K. LOADING LIMITATIONS

The following limitations must be observed in the operation of this airplane.

1. Fill tip tanks first; use main tanks first.
2. This airplane must not be operated at gross weights in excess of 3112 pounds unless the weight over 3112 pounds is fuel weight only.
3. Remove fuel from the main tanks first when required for proper weight and balance.

L. NOSE WHEEL FAIRING REMOVED

When the nose wheel fairing is removed, two nose wheel centering springs (part number 67168) must be installed.

M. NOISE LEVEL (Ser. nos. 7640001 and up)

No noise reduction procedures are required for this airplane. The noise level achieved during type certification was 79.27 d B (A). No determination has been made by the Federal Aviation Administration that the noise levels of this airplane are or should be acceptable or unacceptable for operation at, into or out of any airport.

SECTION II
PROCEDURES

1. The stall warning system is inoperative with the master switch off.
2. Electric fuel pump must be on for both landing and takeoff.
3. Except as noted above, all operating procedures for this airplane are normal.
4. When operating with the rear cabin door removed, it is recommended that all occupants wear parachutes.
5. Air conditioned Models only: Warning - the air conditioner must be off to insure normal takeoff performance.
6. Fuel System Preflight Procedure:

The fuel system should be drained daily prior to first flight and after refueling to avoid the accumulation of water or sediment. Each fuel tank is equipped with an individual quick drain located at the lower inboard rear corner of the tank. The fuel strainer and a system quick drain valve are located in the fuselage at the lowest point of the fuel system. It is important that the fuel system be drained in the following manner:

- a. Drain each tank through its individual quick drain located at the lower inboard rear corner of the tank, making sure that enough fuel has been drained to insure that all water and sediment is removed.
- b. Place a container under the fuel sump drain outlet, which is located under the fuselage.
- c. Drain the fuel strainer by pressing down on the lever located on the right hand side of the cabin below the forward edge of the rear seat. The fuel selector must be positioned in the following sequence: off position, left tip, left main, right main, and right tip while draining the strainer to insure that the fuel lines between each tank outlet and fuel strainer are drained as well as the strainer. When the fuel tanks are full, it will take approximately 11 seconds to drain all the fuel in one of the lines between a tip tank and the fuel strainer and approximately six seconds to drain all the fuel in one of the lines from a main tank to the fuel strainer. When the fuel tanks are less than full, it will take a few seconds longer.

- d. Examine the contents of the container placed under the fuel sump drain outlet for water and sediment and dispose of the contents.

CAUTION

When draining any amount of fuel, care should be taken to insure that no fire hazard exists before starting engine.

After using the under-seat quick drain, it should be checked from outside to make sure it has closed completely and is not leaking.

SECTION III
PERFORMANCE

All performance is given for a weight of 3400 pounds.

Loss of altitude during stalls can be as great as 350 feet, depending on configuration and power.

Stalling speed, in mph, (Calibrated Airspeed):

Flaps Up - 71
Flaps Down - 63

Flap deflection versus handle position is:

1st notch - 10 degrees
2nd notch - 25 degrees
3rd notch - 40 degrees

Air Conditioned Models Only:

When the full throttle position is not used or in the event of a malfunction which causes the compressor to operate and the condenser door to remain extended, a decrease in rate of climb of as much as 100 fpm can be expected at all altitudes.

SECTION IV

OPTIONAL EQUIPMENT

NOTE

THE INFORMATION CONTAINED IN THIS SECTION
APPLIES WHEN THE RELATED EQUIPMENT IS INSTALLED
IN THE AIRCRAFT.

- A. Electric Pitch Trim Installation
- B. AutoFlite II Installation
- C. Air Conditioner Installation
- D. Piper AutoControl III and/or AutoControl IIIB Installation
- E. Piper AltiMatic IIIC Installation

A. ELECTRIC PITCH TRIM INSTALLATION

The following emergency information applies in case of electric pitch trim malfunction.

1. In case of malfunction, disengage electric pitch trim by operating push button trim switch on instrument panel.
2. In emergency, electric pitch trim may be overpowered using manual pitch trim.
3. In cruise configuration, malfunction results in 10° pitch change and 50 ft altitude variation.

D. PIPER AUTOCONTROL III AND/OR AUTOCONTROL IIIB INSTALLATION**1. LIMITATIONS**

- a. Autopilot OFF during takeoff and landing.
- b. Autopilot use prohibited above 180 MPH CAS.

2. PROCEDURES**a. PREFLIGHT****(1) Roll Section**

- (a) Place Radio Coupler in "Heading" mode and place A/P ON/OFF switch in the "ON" position to engage roll section. Rotate roll command knob Left and Right and observe control wheel describes a corresponding Left and Right turn, then center knob.
- (b) Set proper D.G. Heading on D.G. and turn Heading Indice to aircraft heading. Engage "Heading" mode switch and rotate Heading Indice right and left. Aircraft control wheel should turn same direction as Indice. While D.G. indice is set for a left turn, grasp control wheel and override the servo to the right. Repeat in opposite direction for right turn.
- (c) If VOR signal available check Omni mode on Radio Coupler by swinging Omni needle left and right slowly. Observe that control wheel rotates in direction of needle movement.
- (d) Disengage by placing the A/P ON/OFF switch to the "OFF" position.

b. IN-FLIGHT

- (1) Trim airplane (ball centered).
- (2) Check air pressure or vacuum to ascertain that the Directional Gyro and Attitude Gyro are receiving sufficient air.
- (3) Roll Section
 - (a) To engage, center Roll Command Knob, place the A/P ON/OFF switch to the "ON" position. To turn rotate roll command knob in desired direction. (Maximum angle of bank should not exceed 30°.)
 - (b) For heading mode, set Directional Gyro with Magnetic Compass. Push directional gyro HDG knob in, rotate to aircraft heading. Place the console HDG ON/OFF switch to the "ON" position. To select a new aircraft heading, push D.G. heading knob IN and rotate, in desired direction of turn, to the desired heading.

NOTE

In HDG mode the maximum bank angles are limited to approximately 20° and single command, heading changes should be limited to 150°. (HDG Indice not more than 150° from actual aircraft heading.)

(4) VOR

(a) To Intercept:

1. Using OMNI Bearing Selector, dial desired course, inbound or outbound.
2. Set identical heading on Course Selector D.G.
3. After aircraft has stabilized, position coupler mode selector knob to OMNI mode. As aircraft nears selected radial, interception and crosswind correction will be automatically accomplished without further switching.

NOTE

If aircraft position is less than 45° from selected radial, aircraft will intercept before station. If position is more than 45°, interception will occur after station passage. As the aircraft nears the OMNI station, (1/2 mile) the zone of confusion will direct an "S" turn in alternate directions as the OMNI indicator needle swings. This alternate banking limited to the standard D.G. bank angle, is an indication of station passage.

(b) To select new course:

1. To select a new course or radial, rotate the HDG indice to the desired HDG (match course).
2. Rotate OBS to the new course. Aircraft will automatically turn to the intercept heading for the new course.

(c) To change stations:

1. If same course is desired, merely tune receiver to new station frequency.
2. If different course is desired, position coupler mode selector to HDG mode. Dial course selector D.G. to new course. Dial OBS to new course and position coupler mode selector to OMNI mode.

(5) VOR Approach

Track inbound to station as described in VOR navigation section.

After station passage:

- (a) Dial outbound course on Course Selector D.G., then dial same course on OBS.
- (b) After established on outbound radial, position coupler mode selector to HDG mode and select outbound procedure turn heading. After 40 seconds to 1 minute select a turn in the desired direction with the Course Selector D.G. to the inbound procedure turn heading.
- (c) Set OBS to inbound course.
- (d) When aircraft heading is 45° to the inbound course, dial Course Selector D.G. to inbound course and position coupler mode selector to OMNI mode.

NOTE

For precise tracking over OMNI station, without "S" turn, position coupler mode selector to HDG mode just prior to station passage. If holding pattern is desired, position coupler mode selector to HDG mode at station passage inbound and select outbound heading in direction of turn. After elapsed time, dial inbound course on Course Selector D.G. When aircraft heading is 45° to radial, position coupler mode selector to OMNI mode.

(6) LOC Approach Only

- (a) To intercept dial ILS outbound course on Course Selector D.G. When stabilized, position coupler mode selector to LOC REV mode.
- (b) After interception and when beyond outer marker, position coupler mode selector to HDG mode and dial outbound procedure turn heading. After one minute, dial inbound procedure turn heading in direction of turn.
- (c) When aircraft heading is 45° to ILS inbound course dial inbound course on Course Selector D.G. and position coupler mode selector to LOC NORM mode.
- (d) At the missed approach point (M.A.P.), or when missed approach is elected, position coupler mode selector to HDG mode and execute missed approach procedure.

(7) LOC Approach - Back Course (Reverse)

- (a) To intercept dial ILS Back Course outbound heading on Course Selector D.G. When stabilized, position coupler mode selector to LOC NORM mode.
- (b) After interception and when beyond fix, position coupler mode selector to HDG and dial outbound procedure turn heading. After one minute, dial inbound procedure turn heading in direction of turn.
- (c) When heading 45° to inbound course, dial inbound course on Course Selector D.G. and position coupler mode selector to LOC REV mode.
- (d) Approximately 1/2 mile from runway, position coupler mode selector to HDG mode to prevent "S" turn over ILS station near runway threshold.
- (e) Missed approach - same as Front Course. (See (6) d)

c. EMERGENCY OPERATION

- (1) In an emergency the AutoControl can be disconnected by placing the A/P ON/OFF switch to the "OFF" position.
- (2) The AutoControl can be overpowered at either control wheel.
- (3) An Autopilot runaway, with a 3 second delay in the initiation of recovery, while operating in a climb, cruise or descending flight could result in a 38° bank and 40 foot altitude loss.
- (4) An Autopilot runaway, with a 1 second delay in the initiation of recovery, during an approach operation, coupled or uncoupled, could result in an 8° bank and 10 foot altitude loss.

3. PERFORMANCE

No change.

EMERGENCY PROCEDURES

Introduction	4-1
Engine Power Loss During Takeoff	4-1
Engine Power Loss In Flight	4-2
Power Off Landing	4-3
Propeller Overspeed	4-3
Spins	4-4
Open Door	4-4
Fire	4-5
Loss of Oil Pressure	4-6
Loss of Fuel Pressure	4-6
High Oil Temperature	4-6
Alternate Failure	4-7
Engine Roughness	4-7

EMERGENCY PROCEDURES

INTRODUCTION

This section contains procedures that are recommended if an emergency condition should occur during ground operation, takeoff, or in flight. These procedures are suggested as the best course of action for coping with the particular condition described, but are not a substitute for sound judgment and common sense. Since emergencies rarely happen in modern aircraft, their occurrence is usually unexpected, and the best corrective action may not always be obvious. Pilots should familiarize themselves with the procedures given in this section and be prepared to take appropriate action should an emergency arise.

Most basic emergency procedures, such as power off landings, are a normal part of pilot training. Although these emergencies are discussed here, this information is not intended to replace such training, but only to provide a source of reference and review, and to provide information on procedures which are not the same for all aircraft. It is suggested that the pilot review standard emergency procedures periodically to remain proficient in them.

ENGINE POWER LOSS DURING TAKEOFF

The proper action to be taken if loss of power occurs during takeoff will depend on circumstances.

1. If sufficient runway remains for a normal landing, land straight ahead.
2. If insufficient runway remains, maintain a safe airspeed and make only a shallow turn if necessary to avoid obstructions. Use of flaps depends on circumstances. Normally, flaps should be fully extended for touchdown.
3. If you have gained sufficient altitude to attempt a restart, proceed as follows:
 - a. MAINTAIN SAFE AIRSPEED
 - b. FUEL SELECTOR - SWITCH TO ANOTHER TANK CONTAINING FUEL
 - c. ELECTRIC FUEL PUMP - CHECK ON
 - d. MIXTURE - CHECK RICH
 - e. ALTERNATE AIR - ON

NOTE

If engine failure was caused by fuel exhaustion, power will not be regained after tanks are switched until empty fuel lines are filled, which may require up to ten seconds.

If power is not regained, proceed with the POWER OFF LANDING procedure.

ENGINE POWER LOSS IN FLIGHT

Complete engine power loss is usually caused by fuel flow interruption, and power will be restored shortly after fuel flow is restored. If power loss occurs at low altitude, the first step is to prepare for an emergency landing (See POWER OFF LANDING). Maintain an airspeed of at least 100 MPH IAS, and if altitude permits, proceed as follows:

1. Fuel Selector - Switch to another tank containing fuel.
2. Electric Fuel Pump - On
3. Mixture - Rich
4. Alternate Air - On
5. Engine Gauges - Check for an indication of the cause of power loss.
6. If no fuel pressure is indicated, check tank selector position to be sure it is on a tank containing fuel.

When power is restored:

8. Alternate Air - Off
9. Electric Fuel Pump - Off

If the above steps do not restore power, prepare for an emergency landing.

If time permits:

1. Ignition Switch - "L" then "R" then back to "BOTH."
2. Throttle and Mixture - Different settings. (This may restore power if the problem is too rich or too lean a mixture, or if there is partial fuel system restriction.)
3. Try other fuel tanks. (Water in the fuel could take some time to be used up, and allowing the engine to windmill may restore power. If power loss is due to water, fuel pressure indications will be normal.)

NOTE

If engine failure was caused by fuel exhaustion, power will not be regained after tanks are switched until empty fuel lines are filled, which may require up to ten seconds.

If power is not restored, proceed with POWER OFF LANDING procedure.

POWER OFF LANDING

If loss of power occurs at altitude, trim the aircraft for best gliding angle (100 MPH IAS, Air Cond. - OFF), and look for a suitable field. If measures taken to restore power are not effective, and if time permits, check your charts for airports in the immediate vicinity; it may be possible to land at one if you have sufficient altitude. At best gliding angle, with the engine windmilling and the propeller control in full "DECREASE RPM," the airplane will travel approximately one and one half miles for each one thousand feet of altitude. If possible, notify the FAA by radio of your difficulty and intentions. If another pilot or passenger is aboard, let them help.

When you have located a suitable field, establish a spiral pattern around this field. Try to be at 1000 feet above the field at the downwind position to make a normal approach. When the field can easily be reached, slow up to 90 MPH IAS for the shortest landing. Excess altitude may be lost by widening your pattern, using flaps or slipping, or a combination of these.

Touchdown should normally be made at the lowest possible airspeed, with full flaps.

When committed to landing:

1. Ignition - Off
2. Master Switch - Off
3. Fuel Selector - Off
4. Mixture - Idle Cut-Off
5. Seat Belt (and harness if available) - Tight

PROPELLER OVERSPEED

Propeller overspeed is caused by a malfunction in the propeller governor, or low oil pressure, which allows the propeller blades to rotate to full low pitch. If this should occur, proceed as follows:

1. THROTTLE - RETARD
2. OIL PRESSURE - CHECK
3. PROPELLER CONTROL - FULL DECREASE RPM, THEN SET IF ANY CONTROL IS AVAILABLE.
4. REDUCE AIRSPEED
5. THROTTLE - AS REQUIRED TO REMAIN BELOW 2700 RPM.

SPINS

Intentional spins are prohibited in this aircraft. If a spin is inadvertently entered, immediately use the following recovery procedures:

1. THROTTLE - IDLE
2. RUDDER - FULL OPPOSITE TO DIRECTION OF ROTATION
3. CONTROL WHEEL - FULL FORWARD
4. RUDDER - NEUTRAL (WHEN ROTATION STOPS)
5. CONTROL WHEEL - AS REQUIRED TO SMOOTHLY REGAIN LEVEL FLIGHT ATTITUDE

OPEN DOOR

The cabin door on the Cherokee is double latched, so the chances of its springing open in flight at both the top and bottom are remote. However, should you forget the upper latch, or not fully engage the lower latch, the door may spring partially open. This will usually happen at takeoff or soon afterward. A partially open door will not affect normal flight characteristics, and a normal landing can be made with the door open.

If both upper and lower latches are open, the door will trail slightly open, and airspeed will be reduced slightly.

To close the door in flight, proceed as follows:

1. Slow aircraft to 100 MPH IAS.
2. Cabin Vents - Close
3. Storm Window - Open
4. If upper latch is open - latch. If lower latch is open - open top latch, push door further open, and then close rapidly. Latch top latch.

A slip in the direction of the open door will assist in latching procedure.

FIRE

The presence of fire is noted through smoke, smell, and heat in the cabin. It is essential that the source of the fire be promptly identified through instrument readings, character of the smoke, or other indications, since the action to be taken differs somewhat in each case.

SOURCE OF FIRE - CHECK

1. Electrical Fire (Smoke in Cabin):
 - a. Master Switch - Off
 - b. Vents - Open
 - c. Cabin Heat - Off
 - d. Land as soon as possible.

2. Engine Fire (In Flight):
 - a. Fuel Selector - Off
 - b. Throttle - Closed
 - c. Mixture - Idle Cut-Off
 - d. Heater - Off (In all cases of fire)
 - e. Defroster - Off (In all cases of fire)
 - f. If terrain permits, land immediately.

NOTE

The possibility of an engine fire in flight is extremely remote. The procedure given above is general and pilot judgment should be the deciding factor for action in such an emergency.

3. Engine Fire (During Start):

Engine fires during start are usually the result of overpriming. The following procedure is designed to draw the excess fuel back into the induction system.

 - a. If engine has not started:
 - (1) Mixture - Idle Cut-Off
 - (2) Throttle - Open
 - (3) Turn engine with starter (This is an attempt to pull the fire into the engine.)
 - b. If engine has already started and is running, continue operating to try pulling the fire into the engine.
 - c. In either case stated in (a) and (b), if the fire continues longer than a few seconds, the fire should be extinguished by the best available external means.
 - d. If external fire extinguishing is to be applied:
 - (1) Fuel Selector Valves - Off
 - (2) Mixture - Idle Cut-Off

LOSS OF OIL PRESSURE

Loss of oil pressure may be either partial or complete. A partial loss of oil pressure usually indicates a malfunction in the oil pressure regulating system, and a landing should be made as soon as possible to investigate the cause and prevent engine damage.

A complete loss of oil pressure indication may signify oil exhaustion or may be the result of a faulty gauge. In either case, proceed toward the nearest airport, and be prepared for a forced landing. If the problem is not a pressure gauge malfunction, the engine may stop suddenly. Maintain altitude until such time as a dead stick landing can be accomplished. Don't change power settings unnecessarily, as this may hasten complete power loss.

Depending on the circumstances, it may be advisable to make an off airport landing while power is still available, particularly if other indications of actual oil pressure loss, such as sudden increases in temperatures, or oil smoke, are apparent, and an airport is not close.

If engine stoppage occurs, proceed to **POWER OFF LANDING**.

LOSS OF FUEL PRESSURE

1. Electric Boost Pump - On
2. Fuel Selector - Check on full tank

If problem is not an empty fuel tank, land as soon as practical and have engine-driven fuel pump checked.

HIGH OIL TEMPERATURE

An abnormally high oil temperature indication may be caused by a low oil level, an obstruction in the oil cooler, damaged or improper baffle seals, a defective gauge, or other causes. Land as soon as practical at an appropriate airport and have the cause investigated.

A steady, rapid rise in oil temperature is a sign of trouble. Land at the nearest airport and let a mechanic investigate the problem. Watch the oil pressure gauge for an accompanying loss of pressure.

ALTERNATOR FAILURE

Loss of alternator output is detected through zero reading on the ammeter. Before executing the following procedure, insure that the reading is zero and not merely low by actuating an electrically powered device, such as the landing light. If no increase in the ammeter reading is noted, alternator failure can be assumed.

1. Reduce Electrical Load.
2. Alternator Circuit Breakers - Check
3. "Alt" Switch - Off (for 1 second), then On

If the ammeter continues to indicate no output, or alternator will not stay reset, turn off "Alt" switch, maintain minimum electrical load and land as soon as practical. All electrical load is being supplied by the battery.

ENGINE ROUGHNESS

Engine roughness may be caused by dirt in the injector nozzles, induction system icing, or ignition problems. To eliminate roughness, proceed as follows:

1. Mixture - Adjust for maximum smoothness. Engine will run rough if too rich or too lean.
2. Alternate Air - On
3. Electric Fuel Pump - On
4. Fuel Selector - Change tanks to see if fuel contamination is the problem.
5. Engine Gauges - Check for abnormal readings. If any gauge readings are abnormal, proceed accordingly.
6. Magneto Switch - "L" then "R," then back to "BOTH." If operation is satisfactory on either magneto, proceed on that magneto at reduced power, with mixture full rich, to a landing at the first available airport.

If roughness persists, prepare for a precautionary landing at pilot's discretion.

WEIGHT AND BALANCE

FOR

CHEROKEE SIX 300

APPLICABLE TO SERIAL NUMBERS 32-7440001 THROUGH 32-7640130

ISSUED: MAY 14, 1973
REVISED: MARCH 23, 1979

REPORT: VB-551
MODEL: PA-32-300

WEIGHT AND BALANCE

Log of Revisions	5-iii
Weight and Balance	5-1
Weight and Balance Data - Weighing Procedure	5-3
Weight and Balance Data	5-7
C. G. Range and Weight Instructions	5-8

WEIGHT AND BALANCE

In order to achieve the performance, safety and good flying characteristics which are designed into the airplane, it must be flown with the weight and center of gravity (C.G.) position within the approved envelope. The aircraft offers a tremendous flexibility of loading. However, you cannot fill the airplane, with the maximum number of adult passengers, full fuel tanks and maximum baggage. With the flexibility comes responsibility. The pilot must ensure that the airplane is loaded within the loading envelope before he makes a takeoff.

Misloading carries consequences for any aircraft. An overloaded airplane will not take off, climb or cruise as well as a properly loaded one. The heavier the airplane is loaded, the less climb performance it will have.

Center of gravity is a determining factor in flight characteristics. If the C.G. is too far forward in any airplane, it may be difficult to rotate for takeoff or landing. If the C.G. is too far aft, the airplane may rotate prematurely on takeoff or try to pitch up during climb. Longitudinal stability will be reduced. This can lead to inadvertent stalls and even spins; and spin recovery becomes more difficult as the center of gravity moves aft of the approved limit.

A properly loaded aircraft, however, will perform as intended. This airplane is designed to provide excellent performance and safety within the flight envelope. Before the airplane is delivered, it is weighed, and a basic weight and C.G. location is computed. (Basic weight consists of the empty weight of the aircraft plus the unusable fuel and full oil capacity.) Using the basic weight and C.G. location, the pilot can easily determine the weight and C.G. position for the loaded airplane by computing the total weight and moment and then determining whether they are within the approved envelope.

The basic weight and C.G. location for a particular airplane are recorded in the aircraft log book or in the weight and balance section of the Airplane Flight Manual. The current values should always be used. Whenever new equipment is added or any modification work is done, the mechanic responsible for the work is required to compute a new basic weight and basic C.G. position and to write these in the aircraft log book. The owner should make sure that it is done.

A weight and balance calculation can be helpful in determining how much fuel or baggage can be boarded so as to keep the C.G. within allowable limits. If it is necessary to remove some of the fuel to stay within maximum allowable gross weight, the pilot should not hesitate to do so.

The following pages are forms used in weighing an airplane in production and in computing basic weight, basic C.G. position, and useful load. Note that the useful load includes fuel, oil, baggage, cargo and passengers. Following this is the method for computing takeoff weight and C.G.

WEIGHT AND BALANCE DATA

WEIGHING PROCEDURE

At the time of delivery, Piper Aircraft Corporation provides each airplane with the licensed empty weight and center of gravity location. This data is on Page 5-7.

The removal or addition of an excessive amount of equipment or excessive airplane modifications can affect the licensed empty weight and empty weight center of gravity. The following is a weighing procedure to determine this licensed empty weight and center of gravity location:

1. PREPARATION

- a. Be certain that all items checked in the airplane equipment list are installed in the proper location in the airplane.
- b. Remove excessive dirt, grease, moisture, foreign items such as rags and tools from the airplane before weighing.
- c. Defuel airplane. Then open all fuel drains until all remaining fuel is drained. Operate engine on each tank until all undrainable fuel is used and engine stops.
- d. Drain all oil from the engine, by means of the oil drain, with the airplane in ground attitude. This will leave the undrainable oil still in the system. Engine oil temperature should be in the normal operating range before draining.
- e. Place pilot and copilot seats in fourth (4th) notch, aft of forward position. Put flaps in the fully retracted position and all control surfaces in the neutral position. Tow bar should be in the proper location and all entrance and baggage doors closed.
- f. Weigh the airplane inside a closed building to prevent errors in scale readings due to wind.

2. LEVELING

- a. With airplane on scales, block main gear oleo pistons in the fully extended position.
- b. Level airplane (see diagram) deflating nose wheel tire, to center bubble on level.

3. WEIGHING - AIRPLANE EMPTY WEIGHT

- a. With the airplane level and brakes released, record the weight shown on each scale. Deduct the tare, if any, from each reading.

Scale Position and Symbol	Scale Reading	Tare	Net Weight
Nose Wheel (N)			
Right Main Wheel (R)			
Left Main Wheel (L)			
Airplane Empty Weight, as Weighed (T)			

4. EMPTY WEIGHT CENTER OF GRAVITY

- a. The following geometry applies to the PA-32-300 airplane when airplane is level (See Item 2).

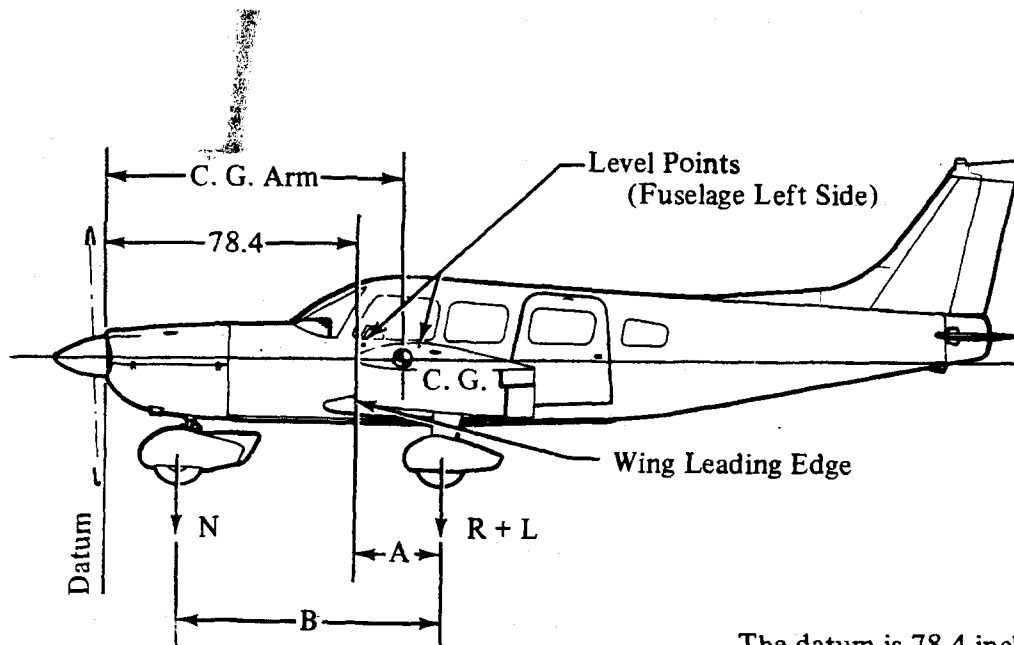

A =

B =

The datum is 78.4 inches ahead of the wing leading edge at the intersection of the straight and tapered section.

- b. Obtain measurement "A" by measuring from a plumb bob dropped from the wing leading edge, at the intersection of the straight and tapered section, horizontally and parallel to the airplane centerline, to the main wheel centerline.
- c. Obtain measurement "B" by measuring the distance from the main wheel centerline, horizontally and parallel to the airplane centerline, to each side of the nose wheel axle. Then average the measurements.
- d. The empty weight center of gravity (as weighed including optional equipment and undrainable oil) can be determined by the following formula:

$$\text{C.G. Arm} = 78.4 + A - \frac{B(N)}{T}$$

$$\text{C. G. Arm} = 78.4 + (\quad) - \frac{(\quad) (\quad)}{(\quad)} = \quad \text{inches}$$

5. LICENSED EMPTY WEIGHT AND EMPTY WEIGHT CENTER OF GRAVITY

	Weight	Arm	Moment
Empty Weight (as weighed)			
Unusable Fuel (.4 gallon)	+2.3	103.0	+237
Licensed Empty Weight			

WEIGHT AND BALANCE DATA
MODEL PA-32-300 CHEROKEE

Airplane Serial Number _____

Registration Number _____

Date _____

AIRPLANE BASIC WEIGHT

Item		Weight (Lbs)	×	C. G. Arm (Inches Aft of Datum)	=	Moment (In-Lbs)
*Empty Weight	Actual Computed					
Unusable Fuel (3.2 pints)		2.3		103.0		237
Standard Empty Weight						
Optional Equipment						
Licensed Empty Weight						
Oil (12 quarts)		22.5		16.6		374
Basic Weight						

*Empty weight is defined as dry empty weight (including paint and hydraulic fluid) plus 2.4 lbs undrainable engine oil.

AIRPLANE USEFUL LOAD - NORMAL CATEGORY OPERATION

(Gross Weight) - (Licensed Empty Weight) = Useful Load

(3400 lbs) - (lbs) = lbs.

THIS LICENSED EMPTY WEIGHT, C. G. AND USEFUL LOAD ARE FOR THE AIRPLANE AS DELIVERED FROM THE FACTORY. REFER TO APPROPRIATE AIRCRAFT RECORD WHEN ALTERATIONS HAVE BEEN MADE.

C. G. RANGE AND WEIGHT INSTRUCTIONS

1. Add the weight of all items to be loaded to the basic weight.
2. Use the loading graph to determine the moment of all items to be carried in the airplane.
3. Add the moment of all items to be loaded to the basic weight moment.
4. Divide the total moment by the total weight to determine the C.G. location.
5. By using the figures of Item 1 and Item 4, locate a point on the C.G. range and weight graph. If the point falls within the C.G. envelope, the loading meets the weight and balance requirements.

SAMPLE LOADING PROBLEM (Normal Category)

	Weight (Lbs)	Arm Aft Datum (Inches)	Moment (In-Lbs)
Basic Weight			
Pilot and Front Passenger	340.0	85.5	29070
Passengers (Center Seats)	340.0	118.1	40154
Passengers (Rear Seats)	340.0	155.7	52938
Passenger (Jump Seat)*		118.1	
Fuel (84-Gallon Maximum)		95.0	
Baggage (Forward)		42.0	
Baggage (Aft)		178.7	
Total Loaded Airplane			

The center of gravity (C.G.) of this sample loading problem is at _____ inches aft of the datum line. Locate this point () on the C.G. range and weight graph. Since this point falls within the weight - C.G. envelope, this loading meets the weight and balance requirements.

IT IS THE RESPONSIBILITY OF THE PILOT AND AIRCRAFT OWNER TO INSURE THAT THE AIRPLANE IS LOADED PROPERLY.

*Optional Equipment.

LOADING GRAPH

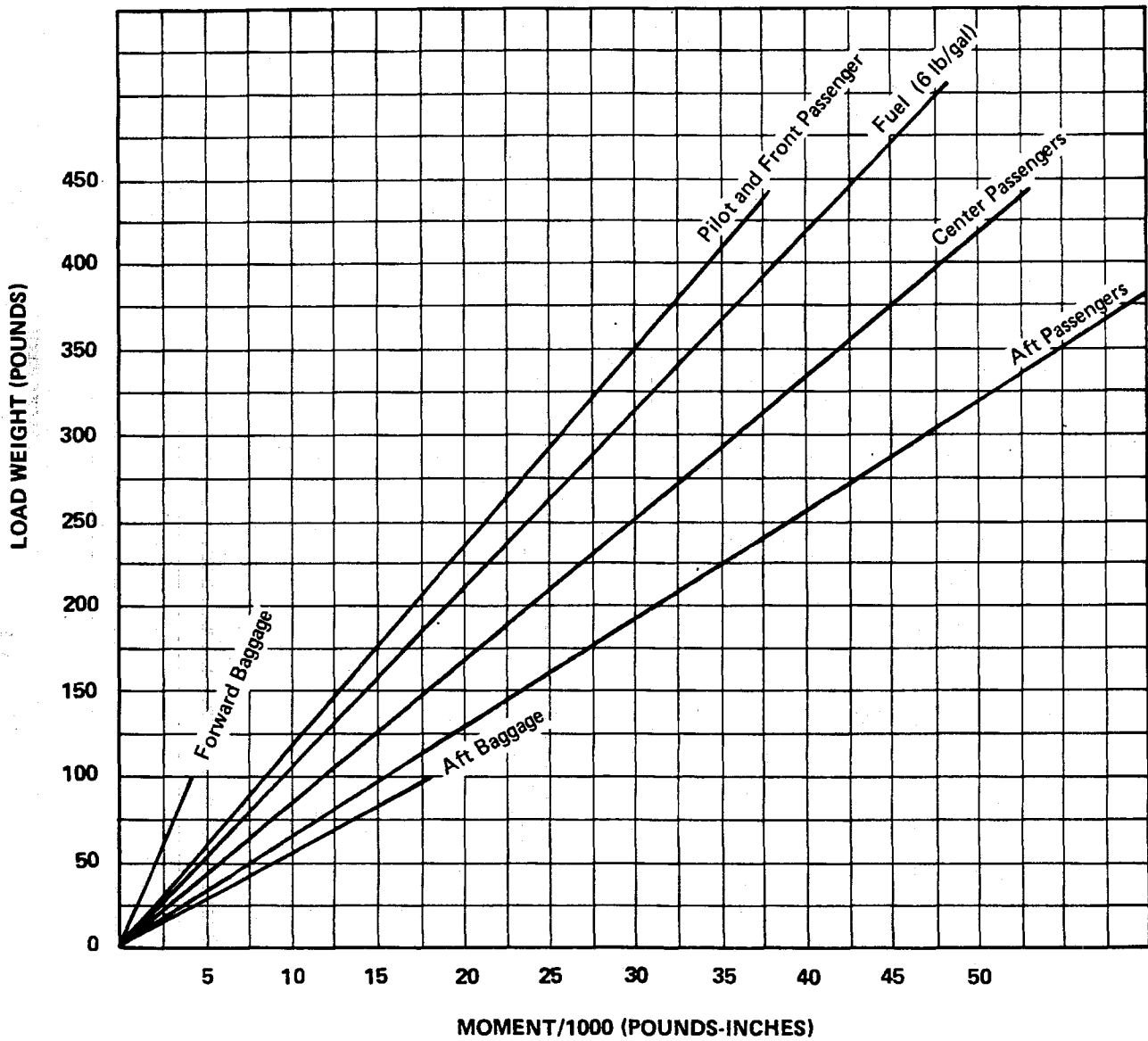

C. G. RANGE AND WEIGHT

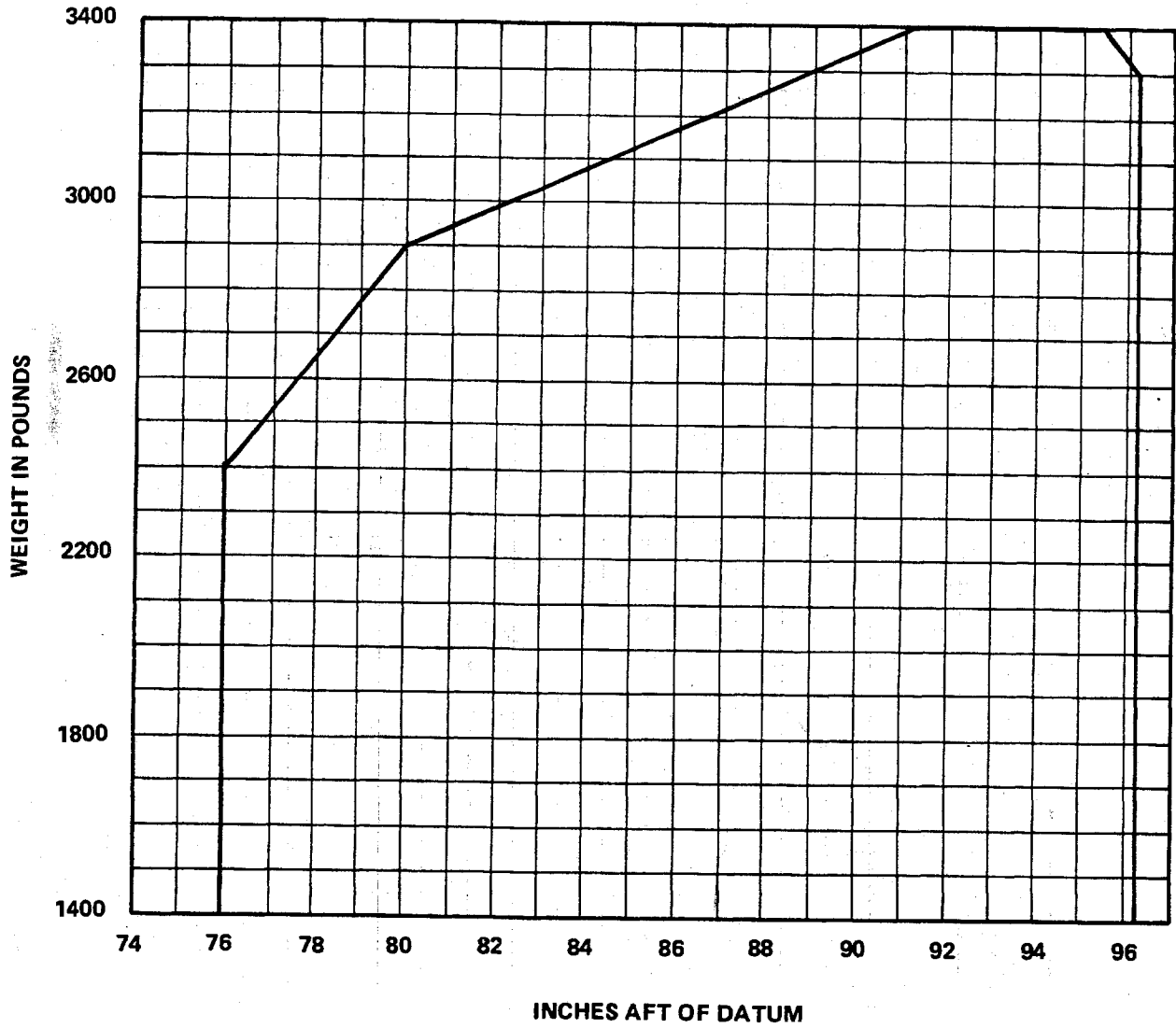

OPERATING INSTRUCTIONS

Preflight	7-1
Starting Engine	7-2
Starting Engine When Cold	7-2
Starting Engine When Hot	7-3
Starting Engine When Flooded	7-3
Starting With External Power Source	7-3
Warm-Up	7-4
Ground Check	7-4
Takeoff	7-5
Climb	7-6
Stalls	7-6
Cruising	7-6
Turbulent Air Operation	7-8
Maneuvers	7-8
Approach and Landing	7-8
Stopping Engine	7-9
Airspeed Data	7-9
Mooring	7-9
Weight and Balance	7-9
Air Conditioning	7-10
Air Conditioner Operational Check Procedure	7-10
Air Conditioner Effects on Airplane Performance	7-11
Emergency Locator Transmitter	7-11

OPERATING INSTRUCTIONS

PREFLIGHT

The airplane should be given a thorough preflight and walk-around inspection. The preflight should include a check of the airplane's operational status, computation of weight and C.G. limits, takeoff distance, and in flight performance. A weather briefing should be obtained for the intended flight path, and any other factors relating to a safe flight should be checked before takeoff.

Walk-Around Inspection

1.
 - a. Release seat belts securing the control wheel.
 - b. Master switch ON.
 - c. Check fuel quantity gauges (four tanks).
 - d. Master switch and ignition OFF.
2.
 - a. Check for external damage and operational interference of control surfaces or hinges.
 - b. Insure that wings and control surfaces are free of snow, ice or frost.
3.
 - a. Visually check wing tip tank fuel supply; secure caps.
 - b. Drain wing tip tank sumps (See Description - Airplane and Systems Section for procedure).

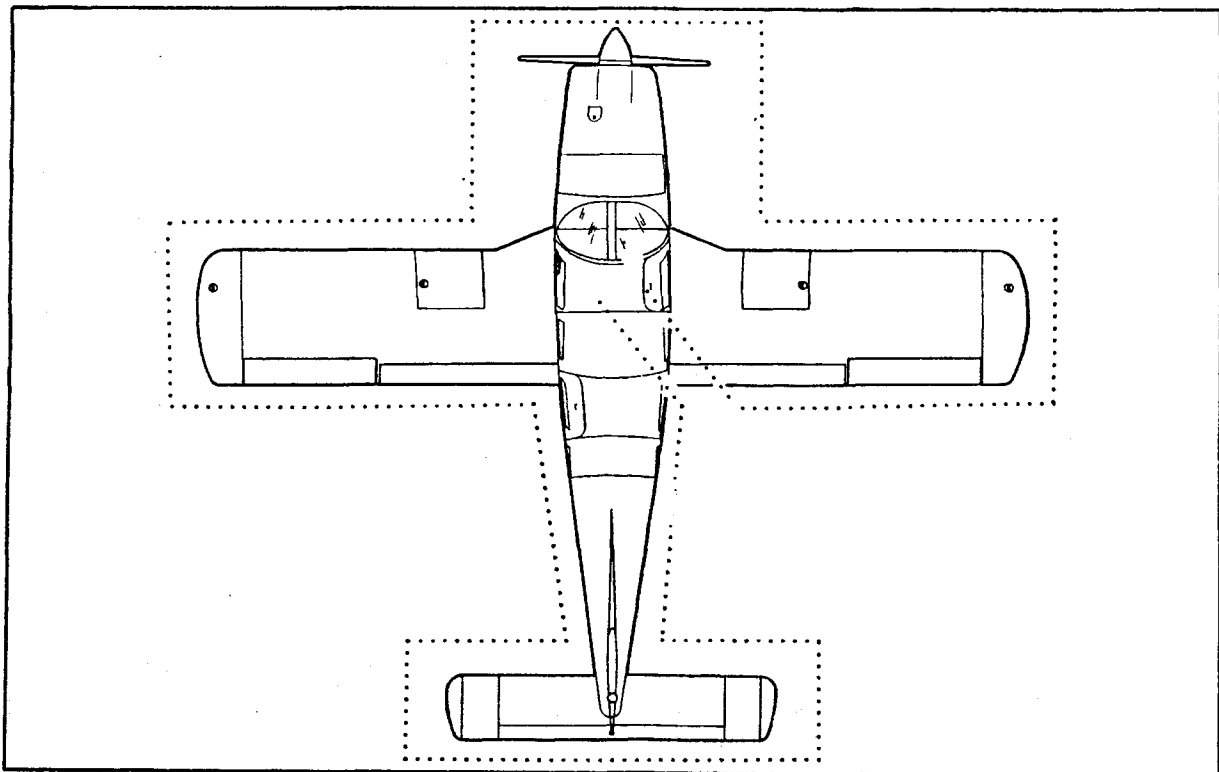

- c. Check navigation lights.
4.
 - a. Visually check main fuel tank fuel supply; secure caps.
 - b. Drain main fuel tank sumps (See Description - Airplane and Systems Section for procedure).
 - c. Check that fuel system vents are open.
 - d. Check main gear shock struts for proper inflation (4-1/2 inches).
 - e. Check tires for cuts, wear, and proper inflation.
 - f. Check brake blocks for wear and damage.
 - g. On left wing check pitot head. Remove cover if used; check that holes are clear.
5.
 - a. Check windshield for cleanliness.
 - b. Check the propeller and spinner for defects or nicks.
 - c. Check for obvious fuel or oil leaks.
 - d. Check oil level. (Insure dipstick is properly seated.)
 - e. Check cowling and inspection covers for security.
 - f. Check nose wheel tire for inflation, wear.
 - g. Check nose wheel shock strut for proper inflation (3-1/4 inches).
 - h. Check air inlets for foreign matter.
 - i. Check alternator belt tension.
6.
 - a. Stow tow bar and control locks if used.
 - b. Check baggage for proper storage and security.
 - c. Close and secure
 - d. Drain fuel strainer sump (See Description - Airplane and Systems Section for procedure).
7.
 - a. Upon entering the aircraft, ascertain that all primary flight controls operate properly.
 - b. Close and secure the fore and aft cabin doors.
 - c. Check that required papers are in order and in the airplane.
 - d. Fasten seat belts and shoulder harness. Check function of inertia reel.

STARTING ENGINE

After completing the preflight inspection:

1. Set brakes ON.
2. Set the propeller in full INCREASE RPM.
3. Select the desired tank with the fuel selector.

STARTING ENGINE WHEN COLD

1. Open the throttle approximately 1/2 inch.
2. Turn the master switch ON.
3. Turn the auxiliary electric fuel pump ON.
4. Move the mixture control to FULL RICH until an indication is noted on the fuel flow meter. (Engine is primed.)
5. Move the mixture control to IDLE CUT-OFF.
6. Engage the starter by rotating the magneto switch clockwise and pressing in.
7. When the engine fires, release the magneto switch; advance the mixture control to FULL RICH; move the throttle to the desired setting.
8. If the engine does not fire within five to ten seconds, disengage the starter and reprime.

STARTING ENGINE WHEN HOT

1. Open the throttle approximately 1/2 inch.
2. Turn the master switch ON.
3. Turn the auxiliary electric fuel pump ON.
4. Mixture control in IDLE CUT-OFF.
5. Engage the starter by rotating the magneto switch clockwise and pressing in. When the engine fires, release the magneto switch; advance the mixture; move the throttle to the desired setting.

STARTING ENGINE WHEN FLOODED

1. Open the throttle full.
2. Turn the master switch ON.
3. Turn the auxiliary electric fuel pump OFF.
4. Mixture control in IDLE CUT-OFF.
5. Engage the starter by rotating the magneto switch clockwise and pressing in. When the engine fires, release the magneto switch; advance the mixture; retard the throttle.

When the engine is firing evenly, advance the throttle to 800 RPM. If oil pressure is not indicated within thirty seconds, stop the engine and determine the trouble. In cold weather it will take a few seconds longer to get an oil pressure indication. If the engine has failed to start, refer to the Lycoming Operating Handbook, Engine Troubles and Their Remedies.

Starter manufacturers recommend that cranking periods be limited to thirty seconds with a two minute rest between cranking periods. Longer cranking periods will shorten the life of the starter.

STARTING WITH EXTERNAL POWER SOURCE*

An optional feature called Piper External Power (PEP) allows the operator to use an external battery to crank the engine without having to gain access to the airplane's battery.

The procedure is as follows:

1. Turn the airplane master switch to OFF.
2. Connect the RED lead of the PEP kit jumper cable to the POSITIVE (+) terminal of an external 12-volt battery and the BLACK lead to the NEGATIVE (-) terminal.
3. Insert the plug of the jumper cable to the socket located on the fuselage.
4. Turn the airplane master switch ON and proceed with the normal engine starting technique.
5. After the engine has started, turn the master switch OFF and disconnect the jumper cable from the airplane.
6. Turn the master switch ON and check the alternator ammeter for indication of output. DO NOT ATTEMPT FLIGHT IF THERE IS NO INDICATION OF ALTERNATOR OUTPUT.

*Optional equipment

WARM-UP

Warm-up the engine at 1000 to 1200 RPM. Avoid prolonged idling at low RPM, as this practice may result in fouled spark plugs.

Takeoff may be made as soon as the ground check is completed, provided that the throttle may be opened fully without backfiring or skipping, and without a reduction in engine oil pressure.

Do not operate the engine at high RPM when running up or taxiing over ground containing loose stones, gravel or any loose material that may cause damage to the propeller blades.

GROUND CHECK

The magnetos should be checked at 2000 RPM with the propeller set at high RPM. Drop off on either magneto should not exceed 175 RPM and the difference between the magnetos should not exceed 50 RPM. Operation on one magneto should not exceed 10 seconds.

Check the vacuum gauge; the indicator should read 5.0" \pm .1" Hg at 2000 RPM.

Check both oil temperature and oil pressure. The temperature may be low for some time if the engine is being run for the first time of the day, but as long as the pressure is within limits the engine is ready for takeoff.

Check the annunciator panel lights with the press-to-test button*.

The propeller control should be moved through its complete range to check for proper operation, and then placed in full INCREASE RPM for takeoff. To obtain maximum RPM, push the pedestal mounted control fully forward on the instrument panel. Do not allow a drop of more than 500 RPM during this check. In cold weather the propeller control should be cycled from high to low RPM at least three times before takeoff to make sure that warm engine oil has circulated.

The electric fuel pump should be turned off after starting or during warm-up to make sure that the engine driven pump is operating. Prior to takeoff the electric pump should be turned ON again to prevent loss of power during takeoff should the engine driven pump fail. The engine is warm enough for takeoff when the throttle can be opened without the engine faltering.

*Serial nos. 7540001 and up

TAKEOFF

Just before takeoff the following items should be checked:

1. Fuel on proper tank
2. Electric fuel pump on
3. Engine gauges checked
4. Alternate air closed
5. Mixture set
6. Propeller set
7. Seat backs erect
8. Fasten belts/harness
9. Empty seats - seat belts snugly fastened
10. Flaps 10° (1st notch)
11. Trim tab set
12. Controls free
13. Doors latched
14. Air conditioner off

The takeoff technique is conventional for the Cherokee Six. The tab should be set slightly aft of neutral, with the exact setting determined by the loading of the aircraft. Allow the airplane to accelerate to 65 to 70 MPH, then ease back on the wheel enough to let the airplane fly itself off the ground. Premature raising of the nose, or raising it to an excessive angle, will result in a delayed takeoff. After takeoff let the aircraft accelerate to the desired climb speed by lowering the nose slightly.

Takeoffs are normally made with flaps extended 10° (first notch).

Short Field, Obstacle Clearance:

Lower flaps to 25° (second notch), accelerate aircraft to 65-70 miles per hour and ease back on the wheel to rotate. After breaking ground, accelerate to best angle of climb speed, 95 miles per hour, and climb past obstacle. Continue climb and accelerate to best rate of climb speed, 105 miles per hour, and slowly retract the flaps.

Short Field, No Obstacle:

Lower flaps to 25° (second notch), accelerate aircraft to 65-70 miles per hour and ease back on the wheel to rotate. After breaking ground, accelerate to best rate of climb speed, 105 miles per hour, and slowly retract the flaps while climbing out.

Soft Field, Obstacle Clearance:

Lower flaps to 25° (second notch), accelerate aircraft, pull nose gear off as soon as possible and lift off at lowest possible airspeed. Accelerate just above the ground to best angle of climb speed, 95 miles per hour, to climb past obstacle clearance height. Continue climb while accelerating to best rate of climb speed, 105 miles per hour, and slowly retract the flaps.

Soft Field, No Obstacle:

Lower flaps to 25° (second notch), accelerate aircraft, pull nose gear off as soon as possible and lift off at lowest possible airspeed. Accelerate just above the ground to best rate of climb speed, 105 miles per hour, and climb out while slowly retracting the flaps.

CLIMB

The best rate of climb at gross weight will be obtained at 105 miles per hour. The best angle of climb may be obtained at 95 miles per hour. At lighter than gross weight these speeds are reduced somewhat.* For climbing en route, a speed of 115 miles per hour is recommended. This will produce better forward speed and increased visibility over the nose during the climb.

When reaching the desired altitude, the electric fuel pump may be turned off.

STALLS

The stall characteristics of the Cherokee Six are conventional. Visual stall warning is provided by a red light located on the left side of the instrument panel which illuminates automatically between 5 and 10 miles per hour above the stall speed. The gross weight stalling speed of the Cherokee Six with power off and full flaps is 63 miles per hour. With the flaps up this speed is increased 8 miles per hour. Loss of altitude during stalls can be as great as 350 feet, depending on configuration and power. The stall speed chart is at gross weight. Stall speeds at lower weights will be correspondingly less.

Stall speed in mph (Calibrated Airspeed):

Flaps Up - 71
Flaps Down - 63

CRUISING

The cruising speed of the Cherokee Six is determined by many factors, including power setting, altitude, temperature, loading, and equipment installed on the airplane.

The normal maximum cruising power is 75% of the rated horsepower of the engine. True airspeeds, which can be obtained at various altitudes and power settings, can be determined from the Performance Charts Section.

When selecting cruising RPM below 2300, limiting manifold pressure for continuous operation, as specified by the appropriate "Avco-Lycoming Operator's Manual," should be observed.

To obtain the desired power, set the manifold pressure and RPM according to the power setting table in this manual. After the desired power settings have been set up, adjust the mixture control for corresponding best power setting as indicated by the fuel flow meter. The low side of the power setting, as shown on the fuel flow meter, indicates best economy for that percent of power while the high side indicated best power.

*To obtain the performance presented in the Performance Section of this manual, full power (full throttle and 2700 RPM) must be used.

Use of the mixture control in cruising flight reduces fuel consumption significantly, especially at higher altitudes. The mixture should be leaned during cruising operation above 5000 feet altitude and at pilot's discretion at lower altitudes when 75% power or less is being used. If any doubt exists as to the amount of power being used, the mixture should be in the FULL RICH position for all operations under 5000 feet.

To lean the mixture, disengage lock* and pull the mixture control until the engine becomes rough, indicating that the lean mixture limit has been reached in the leaner cylinders. Then enrich the mixture by pushing the control towards the instrument panel until engine operation becomes smooth. The fuel flow meter will give a close approximation of the fuel being consumed.

If the airplane is equipped with the optional exhaust gas temperature (EGT) gauge, a more accurate means of leaning is available to the pilot. For this procedure, refer to the "Avco-Lycoming Operator's Manual."

In order to keep the airplane in best lateral trim during cruise flight, the fuel should be used alternately from each main tank, and when these are nearly exhausted, from each tip tank. It is recommended that one main tank be used for one hour after takeoff, the other main tank used until nearly exhausted, then return to the first main tank. When nearly exhausted, turn to one tip tank and alternate at one-half hour intervals to maintain lateral trim.

The following listing contains, as a reminder, a few of the more highly recommended fuel operation procedures:

1. Fuel quantity should be visually checked in all fuel tanks before entering the aircraft.
2. After using the underseat quick drain, it should be checked from outside the aircraft to make sure it has closed completely, and is not leaking.
3. Takeoff should be made on the tank with the highest quantity of fuel to assure best fuel flow, and this tank selected before or immediately after starting in order to allow fuel flow to be adequately established before takeoff. The tank with the highest quantity of fuel should be selected for landing.
4. Fuel tank selection at low altitude is not recommended, since little recovery time is available in the event of an error in tank selection. When switching tanks, make sure that the selector drops into a detent, and is lined up with the desired tank.
5. The electric fuel pump should be turned on before switching tanks, and should be left on for a short period thereafter.
6. To preclude making a hasty selection, and to provide continuity of flow, the selector should be changed to another tank before fuel is exhausted from the tank in use.
7. Operation of the engine driven fuel pump should be checked while taxiing or during pretakeoff engine run up by switching off the electric fuel pump and observing fuel pressure.
8. During cruise, the electric fuel pump should be in the off position so that any malfunction of the engine driven fuel pump is immediately apparent.
9. If signs of fuel starvation should occur at any time during flight, fuel exhaustion should be suspected, at which time the fuel selector should be immediately positioned to a full tank and the electric fuel pump switched to the on position.
10. When the seventh seat is used, all weight in excess of 3112 pounds must be in fuel weight only. Fill tip tanks first and use fuel from main tanks first.

*Serial nos. 7540001 and up

TURBULENT AIR OPERATION

In keeping with good operating practice used in all aircraft, it is recommended that when turbulent air is encountered or expected, the airspeed be reduced to maneuvering speed to reduce the structural loads caused by gusts and to allow for inadvertent speed build-ups which may occur as a result of the turbulence or of distractions caused by the conditions.

MANEUVERS

Intentional spins are prohibited in this airplane. In the event that an inadvertent spin occurs, standard recovery technique should be used immediately.

APPROACH AND LANDING

Before landing check list:

1. Seat backs erect
2. Fasten belts/harness
3. Air Conditioning off
4. Fuel on proper tank
5. Electric fuel pump on
6. Mixture rich
7. Propeller set
8. Flaps down (125 mph)

The airplane should be trimmed to an approach speed of about 90 miles per hour with flaps extended. The flaps can be lowered at speeds up to 125 miles per hour, if desired. The propeller should be set at approximately 2500 RPM to facilitate ample power for an emergency go-around and to prevent overspeeding of the engine if the throttle is advanced sharply. The mixture control should be kept in full rich position to insure maximum acceleration if it should be necessary to open the throttle again.

The amount of flap used during landings and the speed of the aircraft at contact with the runway should be varied according to the landing surface and conditions of wind and airplane loading. It is generally good practice to contact the ground at the minimum possible safe speed consistent with existing conditions.

Normally, the best technique for short and slow landings is to use full flap and enough power to maintain the desired airspeed and approach flight path. Mixture should be full rich, fuel on the fullest tank, and electric fuel pump on. Reduce the speed during the flareout and contact the ground close to the stalling speed (63 to 70 MPH). After ground contact hold the nose wheel off as long as possible. As the airplane slows down, drop the nose and apply the brakes. There will be less chance of skidding the tires if the flaps are retracted before applying the brakes. Braking is most effective when back pressure is applied to the control wheel, putting most of the aircraft weight on the main wheels. In high wind conditions, particularly in strong crosswinds, it may be desirable to approach the ground at higher than normal speeds with partial or no flaps.

STOPPING ENGINE

At the pilot's discretion, the flaps should be raised and the electric fuel pump turned off. After parking, the air conditioner and radios should be turned off, the propeller set in the full increase position, and the engine stopped by disengaging the mixture control lock* and pulling the mixture control out to idle cut-off. The throttle should be left full aft to avoid engine vibration while stopping. Then the magneto and master switches must be turned off and the parking brake set.

AIRSPEED DATA

All airspeeds quoted in this manual are calibrated unless otherwise noted. Calibrated airspeed is indicated airspeed corrected for instrument and position errors. The following table gives the correlation between indicated airspeed and calibrated airspeed if zero instrument error is assumed. This calibration is valid only when flown at maximum gross weight in level flight.

AIRSPEED CORRECTION TABLE

Flaps 0°												
IAS - MPH	60	70	80	90	100	110	120	130	140	150	160	170
CAS - MPH	70	78	85	94	102	111	120	130	139	148	157	166
Flaps 40°												
IAS - MPH	60	70	80	90	100	110	120					
CAS - MPH	68	76	84	93	101	110	119					

MOORING

The Cherokee Six should be moved on the ground with the aid of the nose wheel tow bar provided with each plane and secured behind the rear seats. Tie downs can be secured to rings provided under each wing and to the tail skid. The aileron and stabilator controls should be secured by looping the safety belt through the control wheel and pulling it snug. The rudder is held in position by its connections to the nose wheel steering and normally does not have to be secured. The flaps are locked when in the full up position and should be left retracted.

WEIGHT AND BALANCE

It is the responsibility of the owner and pilot to determine that the airplane remains within the allowable weight vs. center of gravity envelope while in flight. For weight and balance data see the Airplane Flight Manual and Weight and Balance Sections.

*Serial nos. 7540001 and up

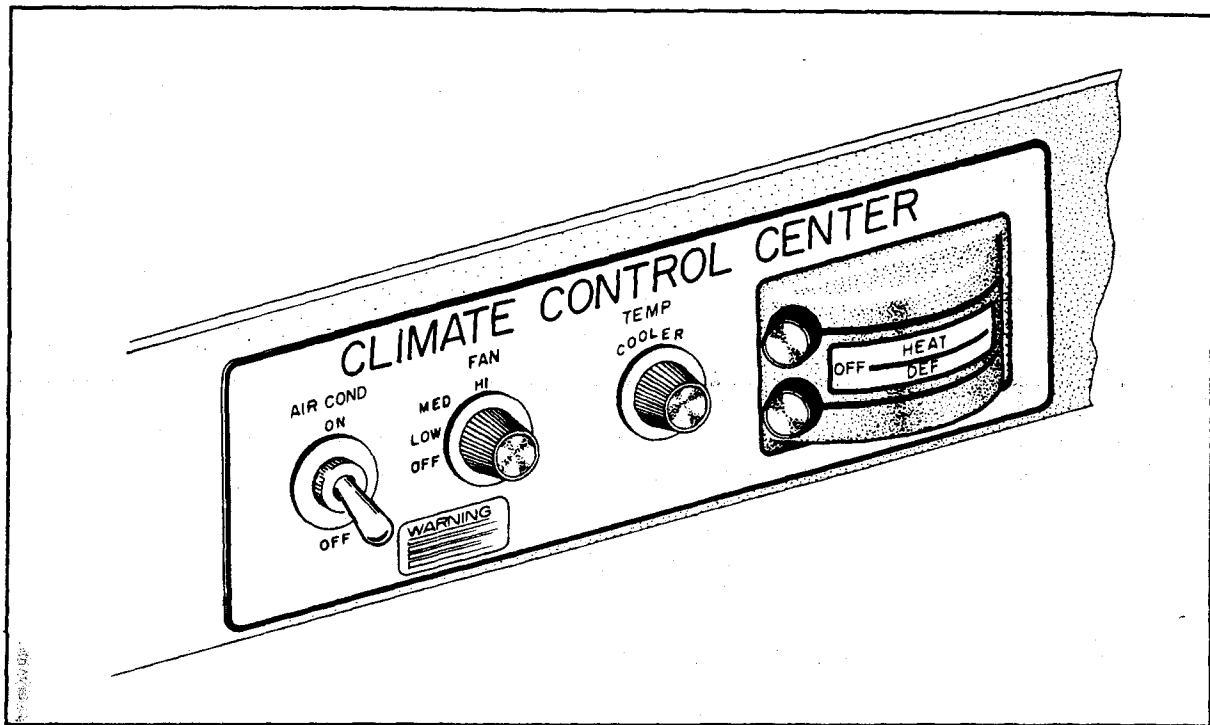

Air Conditioner Controls

AIR CONDITIONING*

To operate the air conditioning system either on the ground or in flight:

1. Start the engine.
2. Turn the air conditioning Master Switch to "ON."
3. Turn "TEMP" control to desired temperature. Clockwise rotation increases cooling.
4. Select desired "FAN" position, "LOW," "MED" or "HIGH."

AIR CONDITIONER OPERATIONAL CHECK PROCEDURE

Prior to takeoff the air conditioner should be checked for proper operation as follows:

1. Check aircraft Master Switch ON.
2. Select desired "FAN" position, "LOW," "MED" or "HIGH."
3. Turn the air conditioner control switch to "ON" - the "Air Cond. Door Open" warning light will turn on, thereby indicating proper air conditioner condenser door actuation.
4. Turn the air conditioner control switch to "OFF" - the "Air Cond. Door Open" warning light will go out, thereby indicating the air conditioner condenser door is in the up position.

*Optional equipment

5. If the "Air Cond. Door Open" light does not respond as specified above, an air conditioner system or indicator bulb malfunction is indicated, and further investigation should be conducted prior to flight.

The above operational check may be performed during flight if an in flight failure is suspected.

AIR CONDITIONER EFFECTS ON AIRPLANE PERFORMANCE

Operation of the air conditioner will cause slight decreases in cruise speed and range. Power from the engine is required to run the compressor, and the condenser door, when extended, causes a slight increase in drag. When the air conditioner is turned off there is normally no measurable difference in climb, cruise or range performance of the airplane.

NOTE

To insure maximum climb performance the air conditioner must be turned off manually before takeoff to disengage the compressor and retract the condenser door. Also the air conditioner must be turned off manually before the landing approach in preparation for a possible go-around.

Although the cruise speed and range are only slightly affected by the air conditioner operation, these changes should be considered in preflight planning. To be conservative, the following figures assume that the compressor is operating continuously while the airplane is airborne. This will be the case only in extremely hot weather.

1. The decrease in true airspeed is approximately 5 mph at all power settings.
2. The decrease in range may be as much as 35 statute miles for the 84 gallon capacity.

The climb performance is not compromised measurably with the air conditioner operating since the compressor is declutched and the condenser door is retracted, both automatically, when a full throttle position is selected. When the full throttle position is not used or in the event of a malfunction which would cause the compressor to operate and the condenser door to be extended, a decrease in rate of climb of as much as 100 fpm can be expected. Should a malfunction occur which prevents condenser door retraction when the compressor is turned off, a decrease in rate of climb of as much as 50 fpm can be expected.

EMERGENCY LOCATOR TRANSMITTER*

The Emergency Locator Transmitter (ELT) when installed, is located in the aft portion of the fuselage just below the stabilator leading edge and is accessible through a plate on the right side of the fuselage. (On aircraft manufactured prior to mid-1975, this plate is retained by three steel Phillips head screws. On aircraft manufactured from mid-1975 and on, this plate is attached with three slotted-head nylon screws for ease of removal; these screws may be readily removed with a variety of common items such as a dime, a key, a knife blade, etc. If there are no tools available in an emergency the screw heads may be broken off by any means.) The ELT is an emergency locator transmitter which meets the requirements of FAR 91.52. The unit operates on a self-contained battery. The replacement date as required by FAA regulations is marked on the transmitter label.

*Optional equipment

The unit is equipped with a portable antenna to allow the locator to be removed from the airplane in case of an emergency and used as a portable signal transmitter.

A pilot's remote switch, located on the left side panel, is provided to allow the transmitter to be controlled from inside the cabin.

1. On some models the pilot's remote switch has three positions and is placarded "ON," "AUTO/ARM," and "OFF/RESET." The switch is normally left in the "AUTO/ARM" position. To turn the transmitter off, move the switch momentarily to the "OFF/RESET" position. The aircraft master switch must be "ON" to turn the transmitter "OFF." To activate the transmitter for tests or other reasons, move the switch upward to the "ON" position and leave it in that position as long as transmission is desired.
2. On other models the pilot's remote switch has two positions and is placarded "ON/RESET" and "ARM (NORMAL POSITION)." The switch is normally left in the down or "ARM" position. To turn the transmitter off, move the switch to the "ON/RESET" position for one second then return it to the "ARM" position. To activate the transmitter for tests or other reasons, move the switch upward to the "ON/RESET" position and leave it in that position as long as transmission is desired.

NOTE

If the switch has been placed in the "ON" position for any reason, the "OFF" position has to be selected before selecting "ARM." If "ARM" is selected directly from the "ON" position, the unit will continue to transmit in the "ARM" position.

The locator should be checked during the ground check to make certain the unit has not been accidentally activated. Check by tuning a radio receiver to 121.5 MHz. If there is an oscillating sound, the locator may have been activated and should be turned off immediately. Reset to the "ARM" position and check again to insure against outside interference.

NOTE

If for any reason a test transmission is necessary, the test transmission should be conducted only in the first five minutes of any hour and limited to three audio sweeps. If tests must be made at any other time, the tests should be coordinated with the nearest FAA tower or flight service station.

OPERATING TIPS

Operating Tips 8-1

OPERATING TIPS

The following Operating Tips are of particular value in the operation of the Cherokee PA-32-300.

1. Learn to trim for takeoff so that only a very light back pressure on the wheel is required to lift the airplane off the ground.
2. The best speed for takeoff is about 70 MPH under normal conditions. Trying to pull the airplane off the ground at too low an airspeed decreases the controllability of the airplane in event of engine failure.
3. Flaps may be lowered at airspeeds up to 125 MPH. To reduce flap operating loads, it is desirable to have the airplane at a slower speed before extending the flaps.
4. Before attempting to reset any circuit breaker, allow a two to five minute cooling off period.
5. Before starting the engine, check that all radio switches, light switches and the pitot heat switch are in the off position so as not to create an overloaded condition when the starter is engaged.
6. The overvoltage relay is provided to protect the electronics equipment from a momentary overvoltage condition (approximately 16.5 volts and up), or a catastrophic regulator failure. In the event of a momentary condition, the relay will open and the ammeter will indicate "0" output from the alternator. The relay may be reset by switching the ALT switch to OFF for approximately one second and then returning the ALT switch to ON. If after recycling the ALT switch the condition persists, the flight should be terminated as soon as practical. Reduce the battery load to a minimum. The ALT light on the annunciator panel* will illuminate if the alternator fails. Recycle the ALT switch and check the ALT FIELD circuit breaker. If the failure persists after this action, reduce electrical loads and land as soon as practical.
7. The vacuum gauge is provided to monitor the pressure available to assure the correct operating speed of the vacuum driven gyroscopic flight instruments. It also monitors the condition of the common air filter by measuring the flow of air through the filter.

If the vacuum gauge does not register $5'' \pm .10''$ Hg at 2000 RPM, the following items should be checked before flight:

- a. Common air filter could be dirty or restricted.
- b. Vacuum lines could be collapsed or broken.
- c. Vacuum pump worn.
- d. Vacuum regulator, not adjusted correctly. The pressure, even though set correctly, can read lower under two conditions: (1) Very high altitude, above 12000 feet, (2) Low engine RPM, usually on approach or during training maneuvers. This is normal and should not be considered a malfunction.

*Serial nos. 7540001 and up

8. The shape of the wing fuel tanks is such that in certain maneuvers the fuel may move away from the tank outlet. If the outlet is uncovered, the fuel flow will be interrupted and a temporary loss of power may result. Pilots can prevent inadvertent uncovering of the outlet by avoiding maneuvers which could result in uncovering the outlet.

Extreme running turning takeoffs should be avoided as fuel flow interruption may occur.

Prolonged slips or skids which result in excess of 2000 feet of altitude loss, or other radical or extreme maneuvers which could cause uncovering of the fuel outlet must be avoided as fuel flow interruption may occur when tank being used is not full.

9. Anti-Collision lights should not be operating when flying through overcast and clouds, since reflected light can produce spacial disorientation. Do not operate strobe lights when taxiing in the vicinity of other aircraft.
10. The rudder pedals are suspended from a torque tube which extends across the fuselage. The pilot should become familiar with the proper positioning of his feet on the rudder pedals so as to avoid interference with the torque tube when moving the rudder pedals or operating the toe brakes.
11. In an effort to avoid accidents, pilots should obtain and study the safety related information made available in FAA publications such as regulations, advisory circulars, Aviation News, AIM and safety aids.

PERFORMANCE CHARTS

Altitude Conversion Chart	9-1
Takeoff Performance (Flaps 10°)	9-2
Takeoff Performance (Flaps 25°)	9-3
Climb Performance	9-4
Cruise Performance	9-5
Cruise Performance - Range (3400 Lbs Gross Wt)	9-6
Cruise Performance - Range (2900 Lbs Gross Wt)	9-7
Glide Performance	9-8
Stalling Speed vs Weight	9-9
Stalling Speed vs Angle of Bank	9-10
Landing Performance	9-11
Power Setting Table	9-12

PA-32-300 CHEROKEE SIX

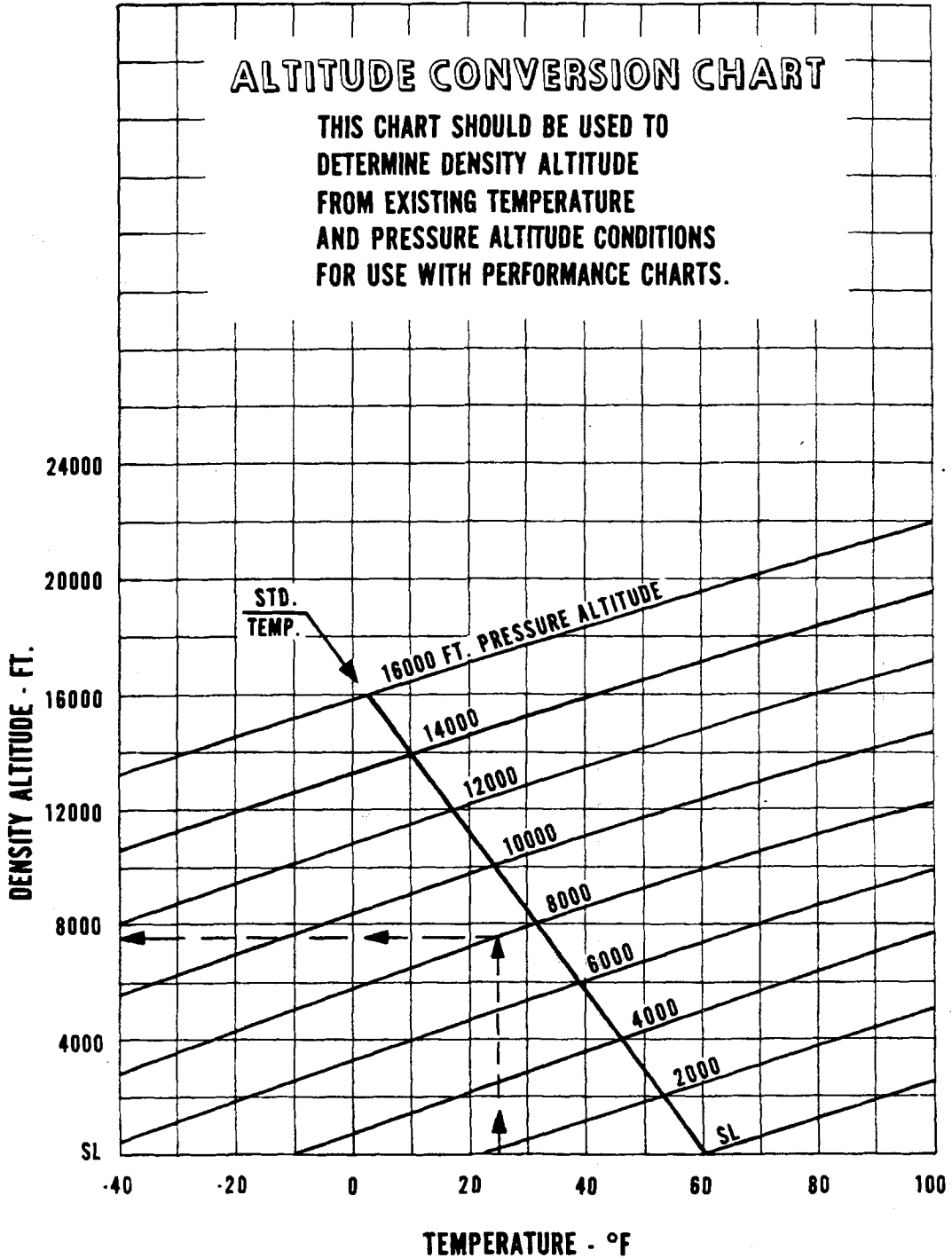

PA-32-300 CHEROKEE SIX

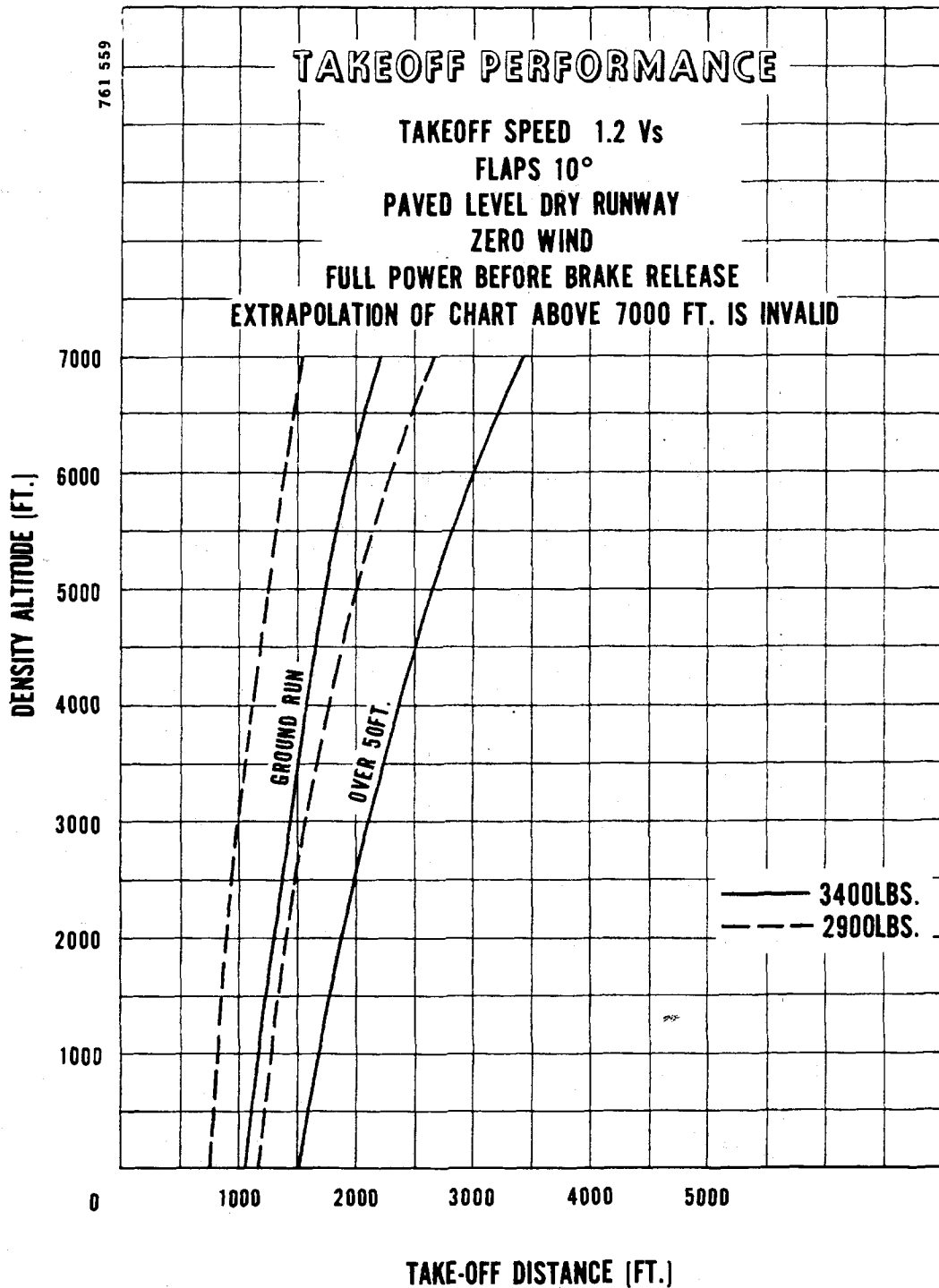

NOTE: SEE SECTION 7 FOR EFFECTS OF AIR CONDITIONING
INSTALLATION ON PERFORMANCE.

PA-32-300 CHEROKEE SIX

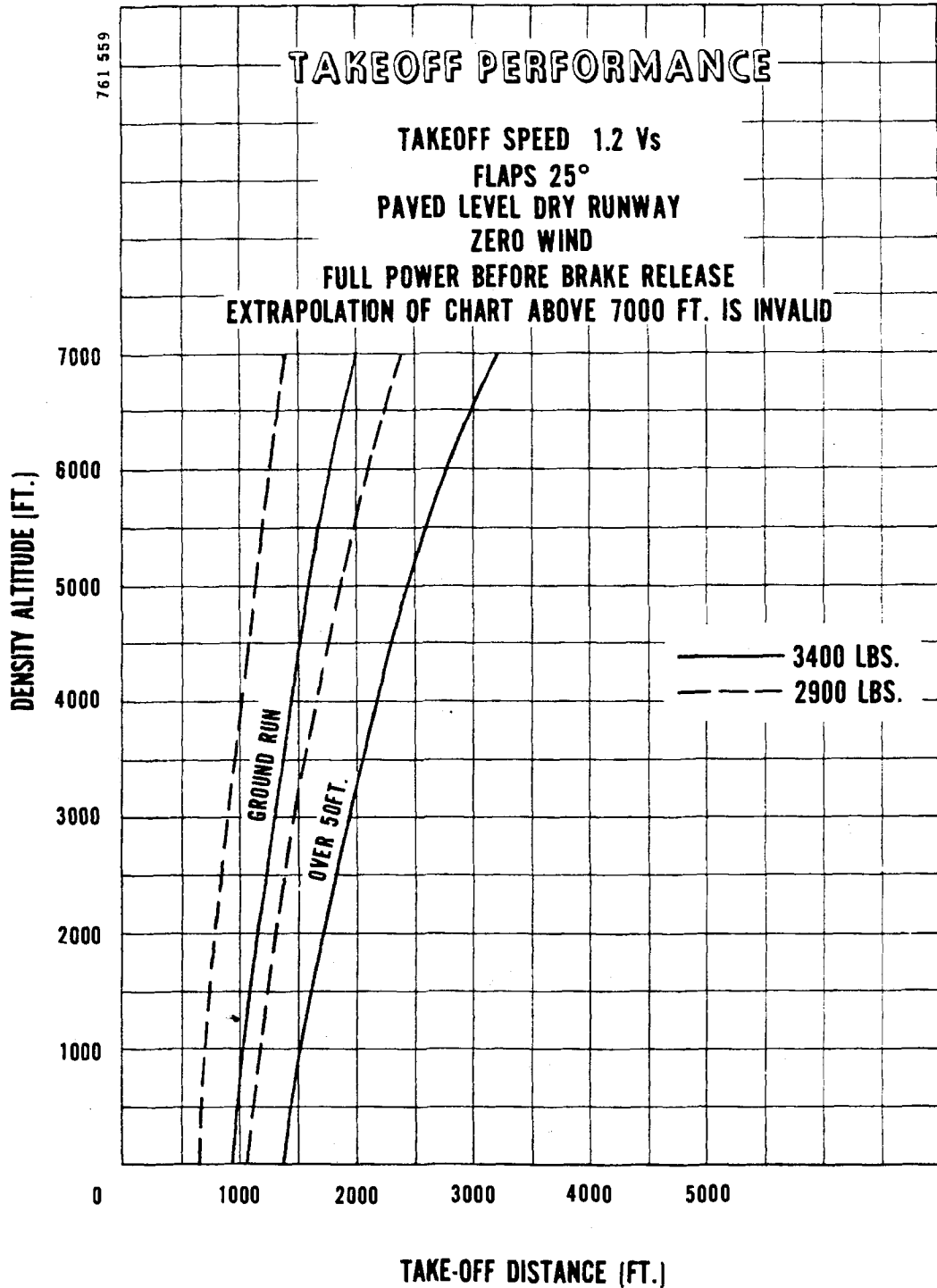

NOTE: SEE SECTION 7 FOR EFFECTS OF AIR CONDITIONING INSTALLATION ON PERFORMANCE.

PA-32-300 CHEROKEE SIX

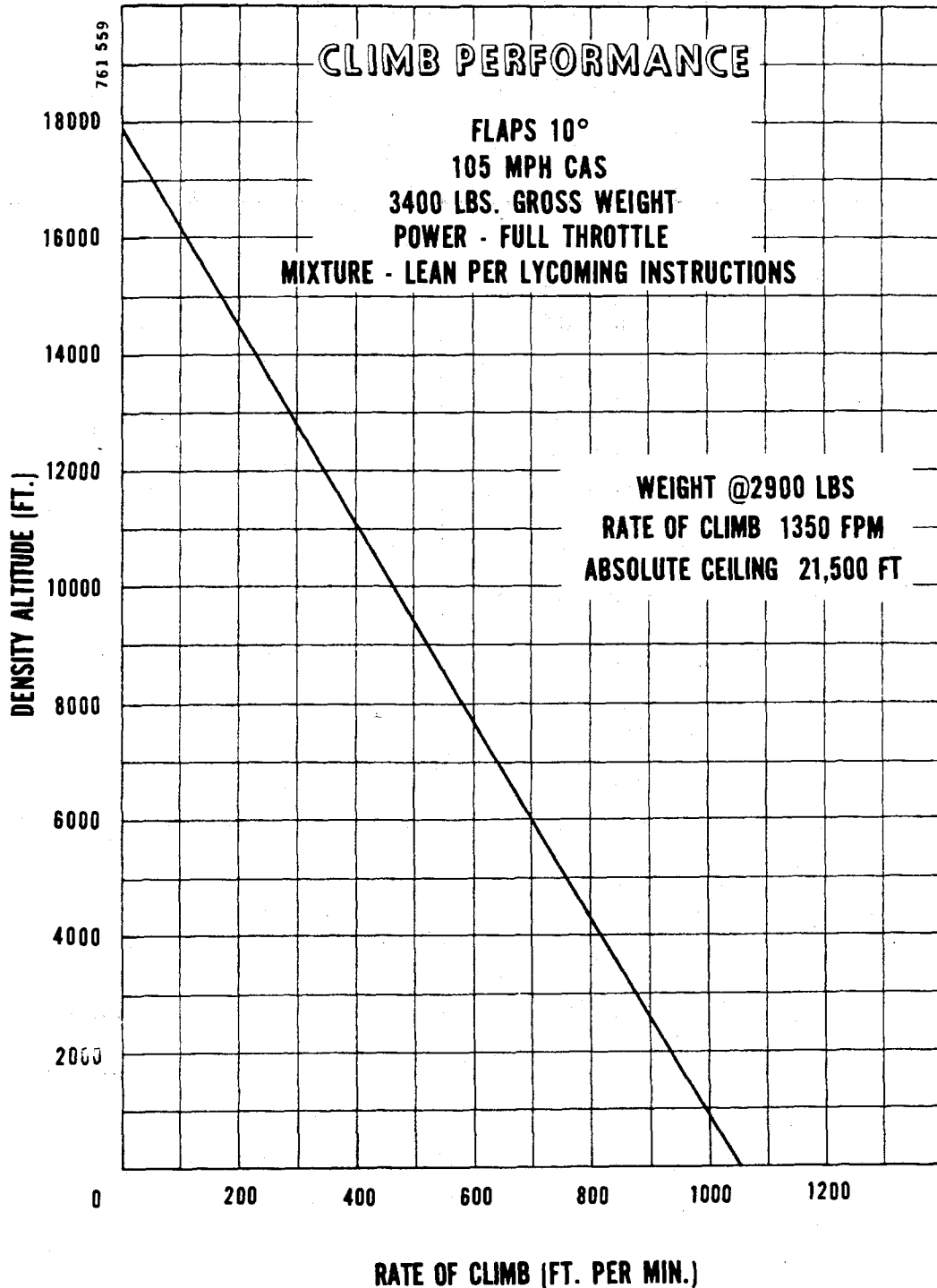

NOTE: SEE SECTION 7 FOR EFFECTS OF AIR CONDITIONING
INSTALLATION ON PERFORMANCE.

PERFORMANCE CHARTS
REVISED: JUNE 20, 1974

PA-32-300 CHEROKEE SIX

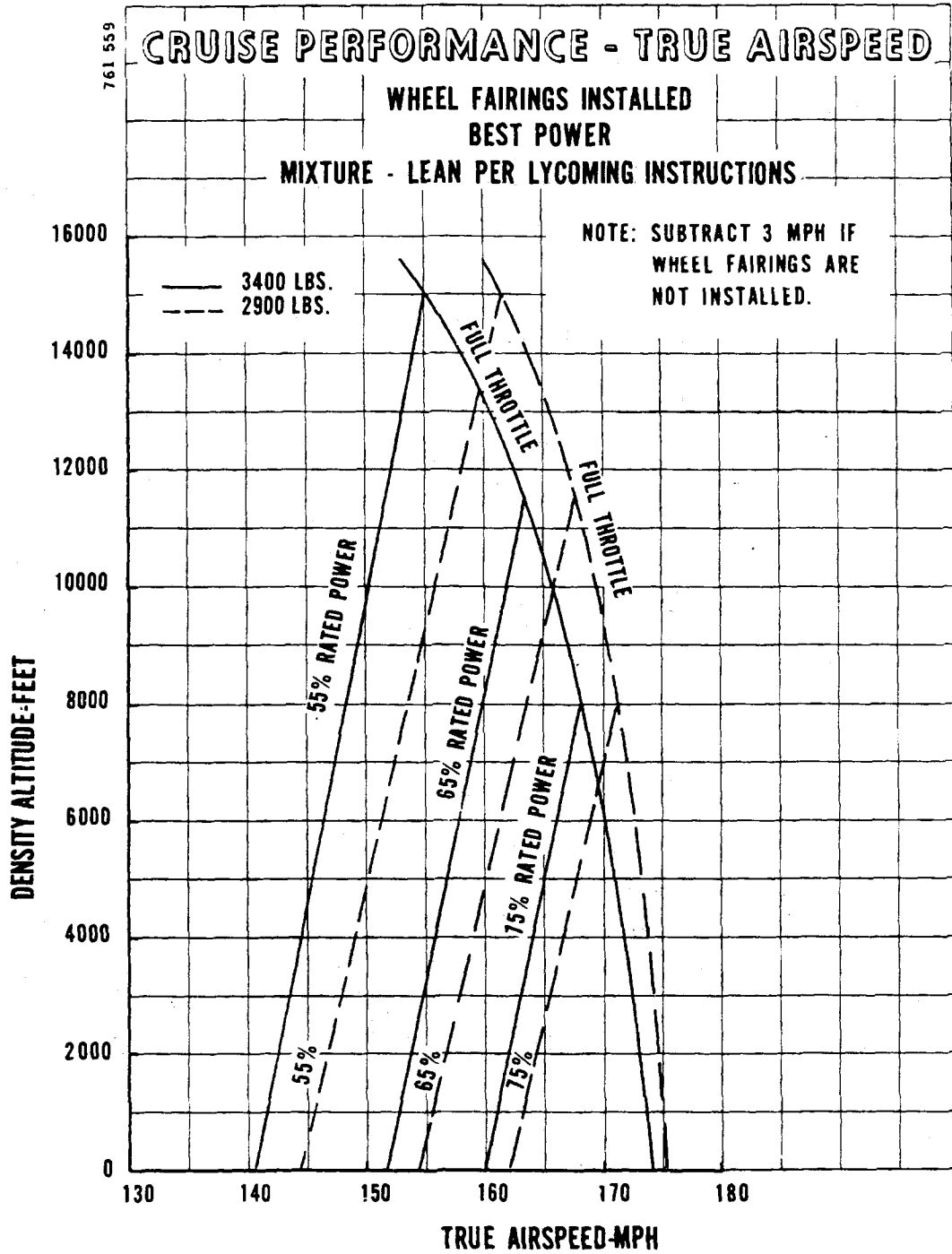

NOTE: SEE SECTION 7 FOR EFFECTS OF AIR CONDITIONING
INSTALLATION ON PERFORMANCE.

PA-32-300 CHEROKEE SIX

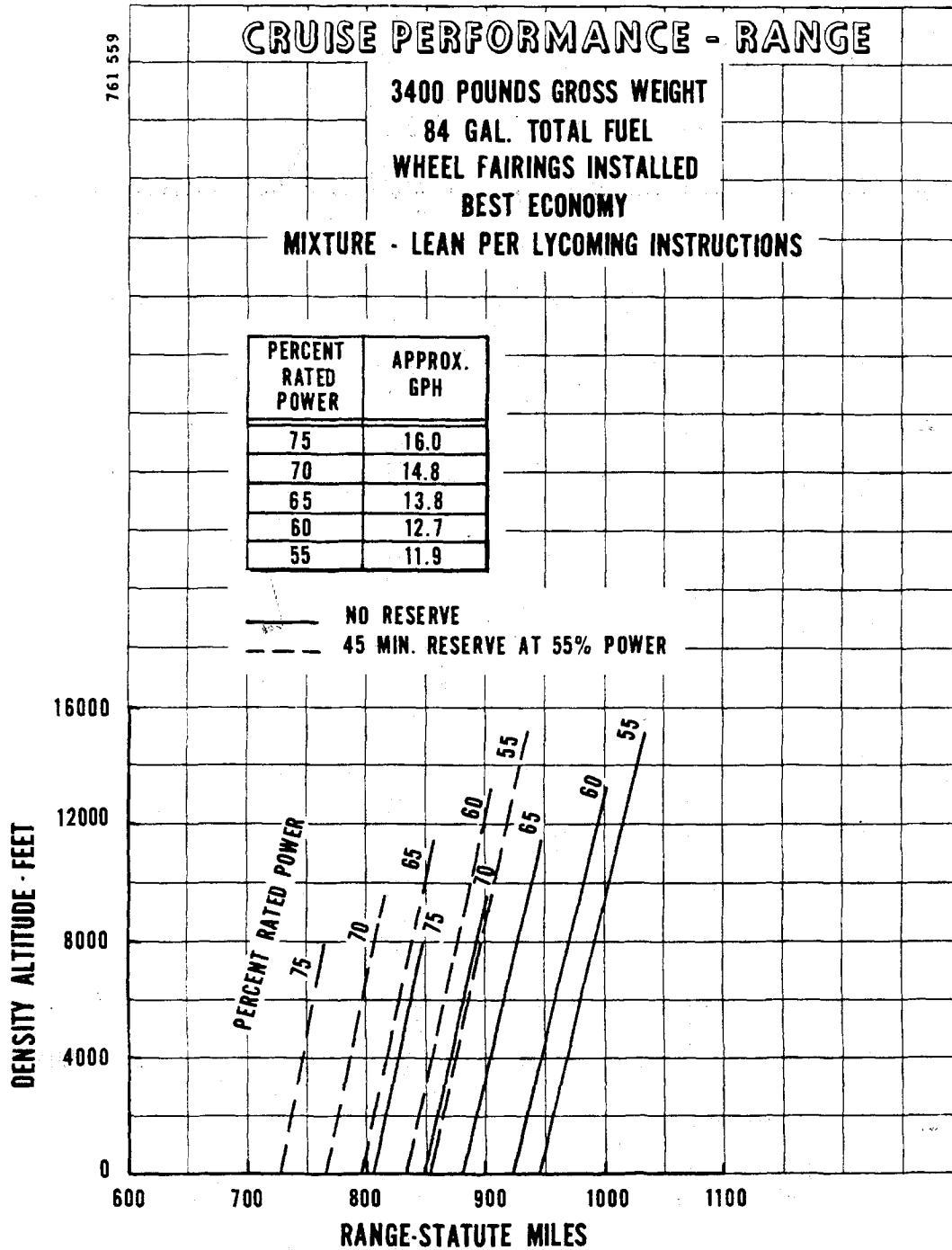

NOTE: SEE SECTION 7 FOR EFFECTS OF AIR CONDITIONING INSTALLATION ON PERFORMANCE.

PA-32-300 CHEROKEE SIX

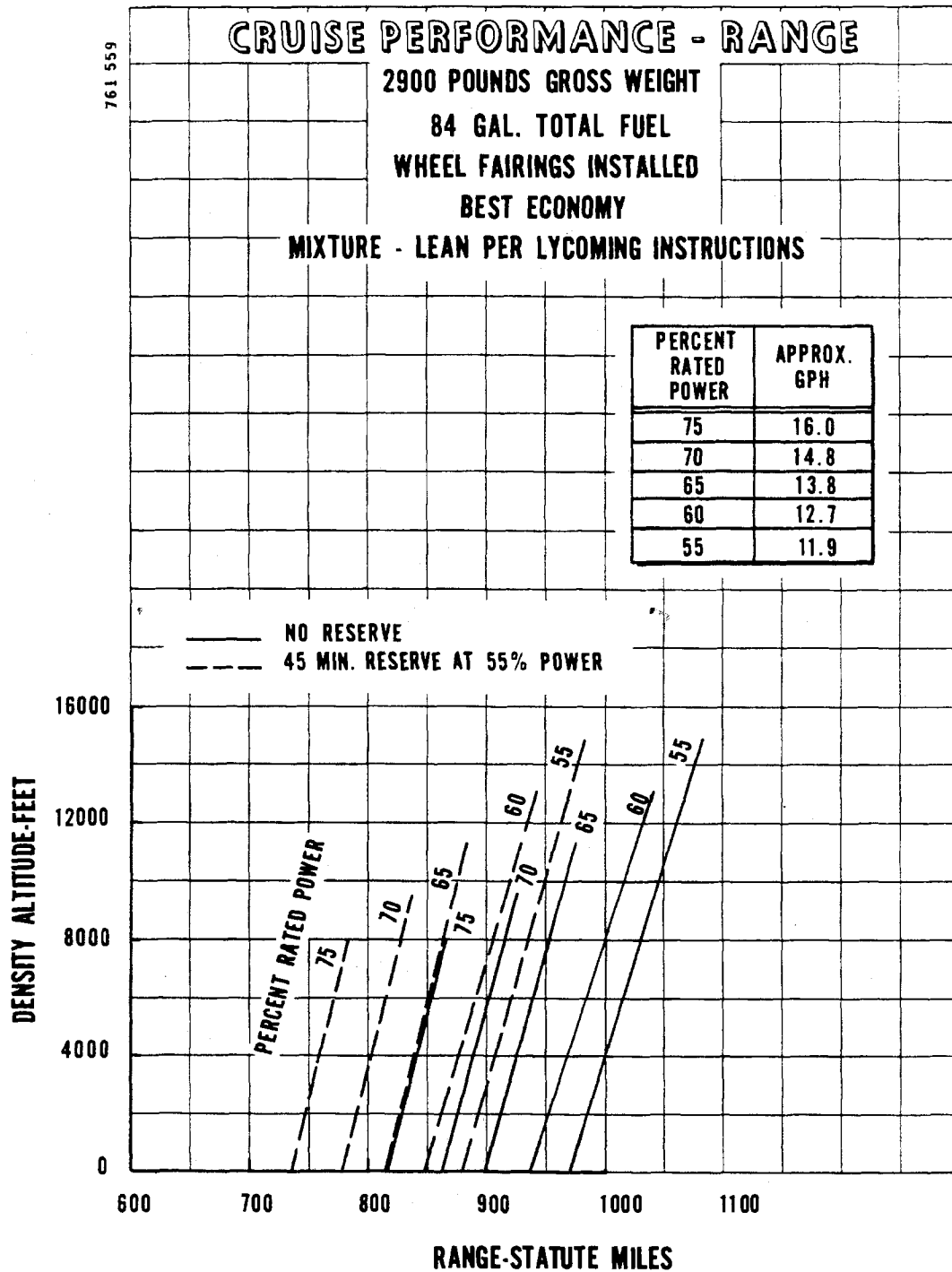

NOTE: SEE SECTION 7 FOR EFFECTS OF AIR CONDITIONING INSTALLATION ON PERFORMANCE.

PERFORMANCE CHARTS
REVISED: JUNE 20, 1974

PA-32-300 CHEROKEE SIX

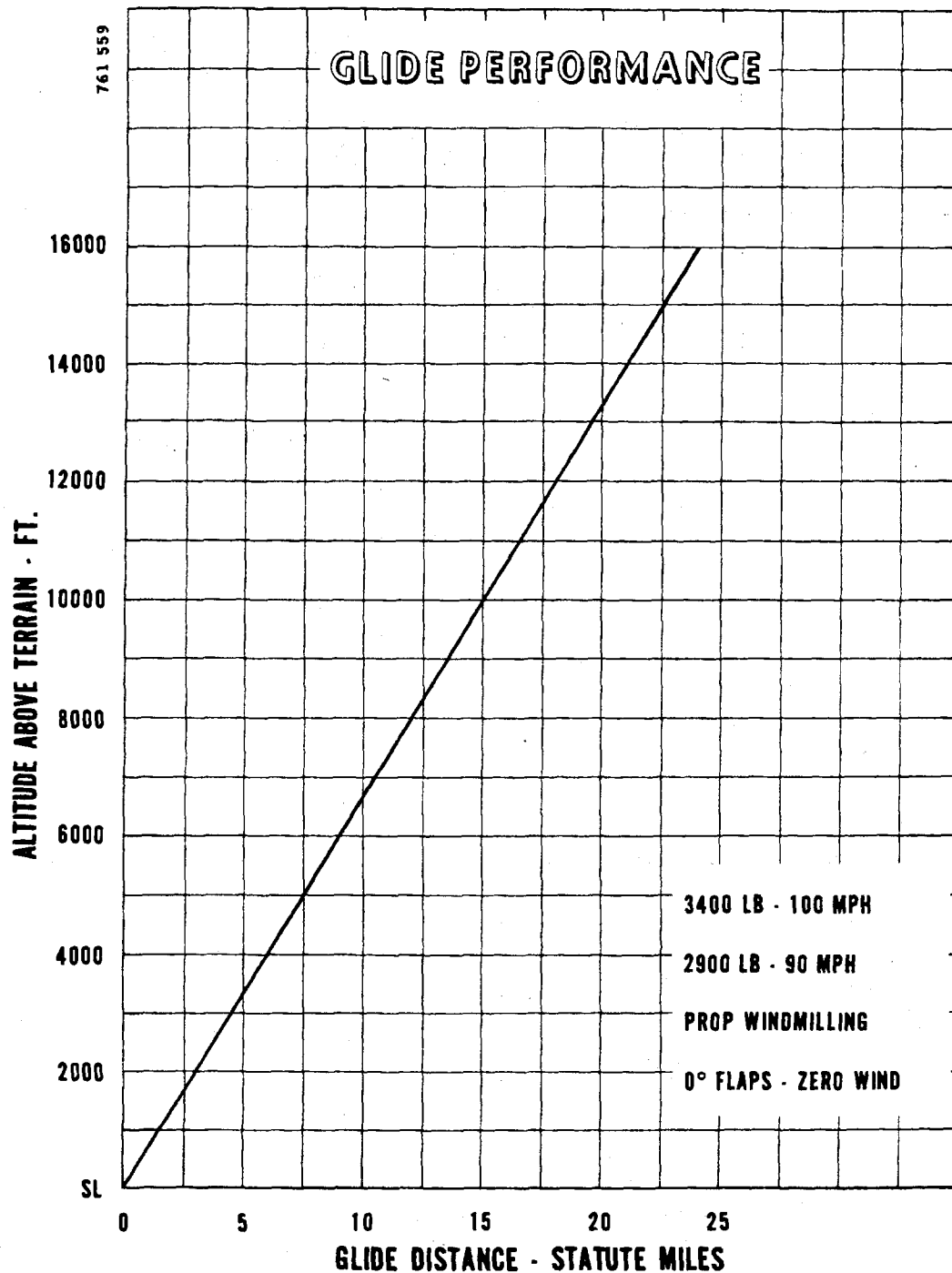

NOTE: SEE SECTION 7 FOR EFFECTS OF AIR CONDITIONING
INSTALLATION ON PERFORMANCE.

PA-32-300 CHEROKEE SIX

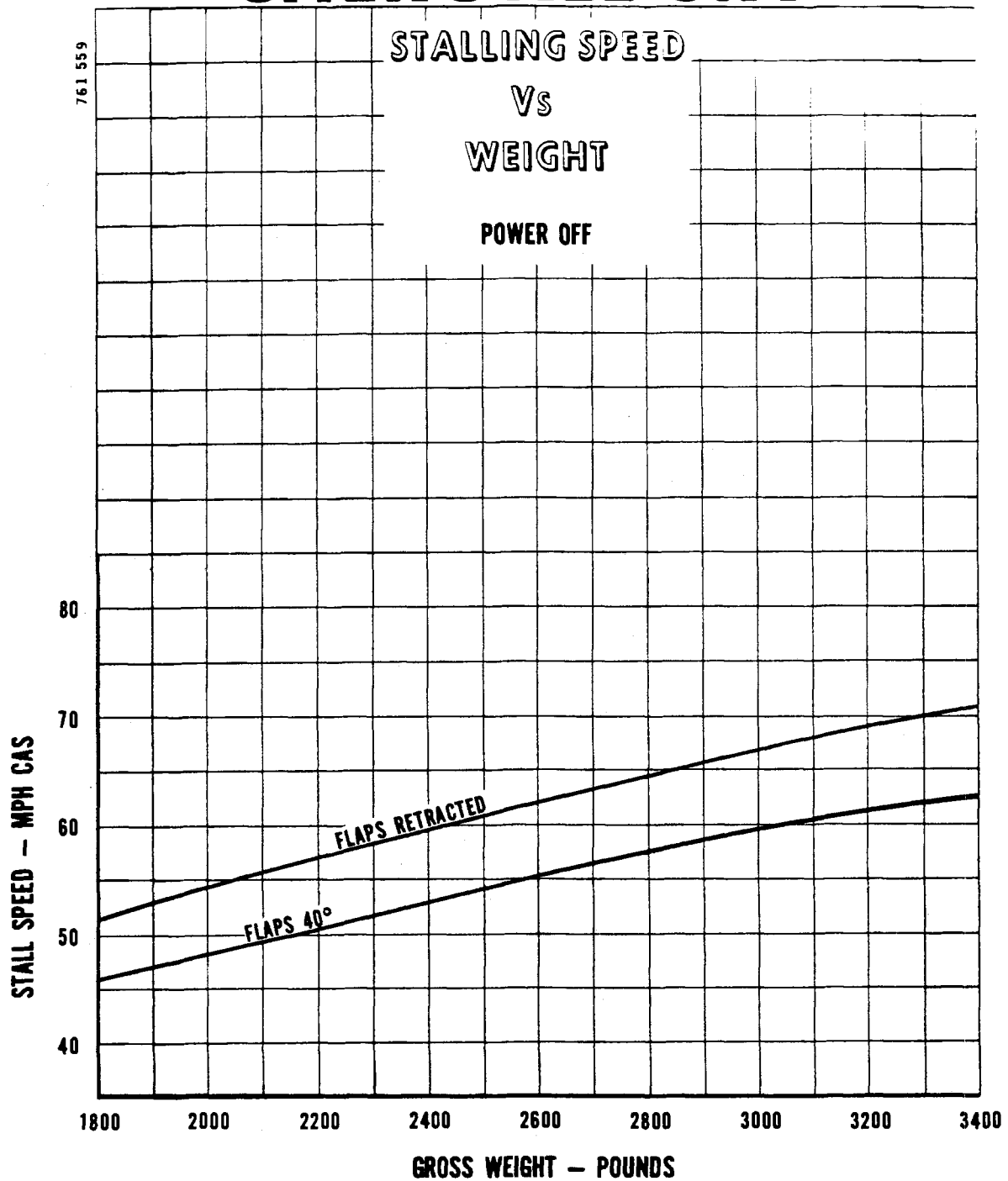

NOTE: SEE SECTION 7 FOR EFFECTS OF AIR CONDITIONING
INSTALLATION ON PERFORMANCE.

PA-32-300 CHEROKEE SIX

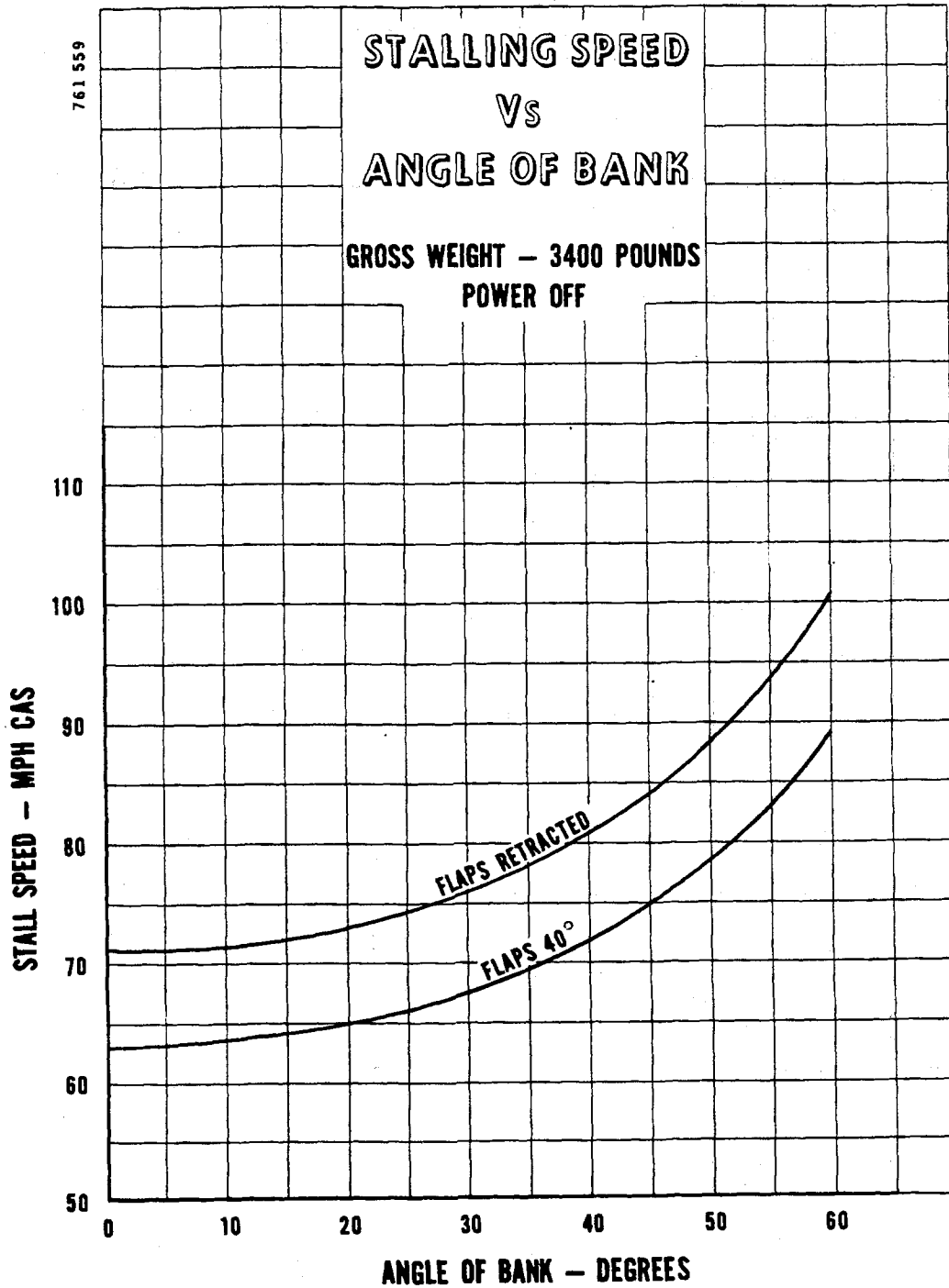

NOTE: SEE SECTION 7 FOR EFFECTS OF AIR CONDITIONING
INSTALLATION ON PERFORMANCE.

PA-32-300 CHEROKEE SIX

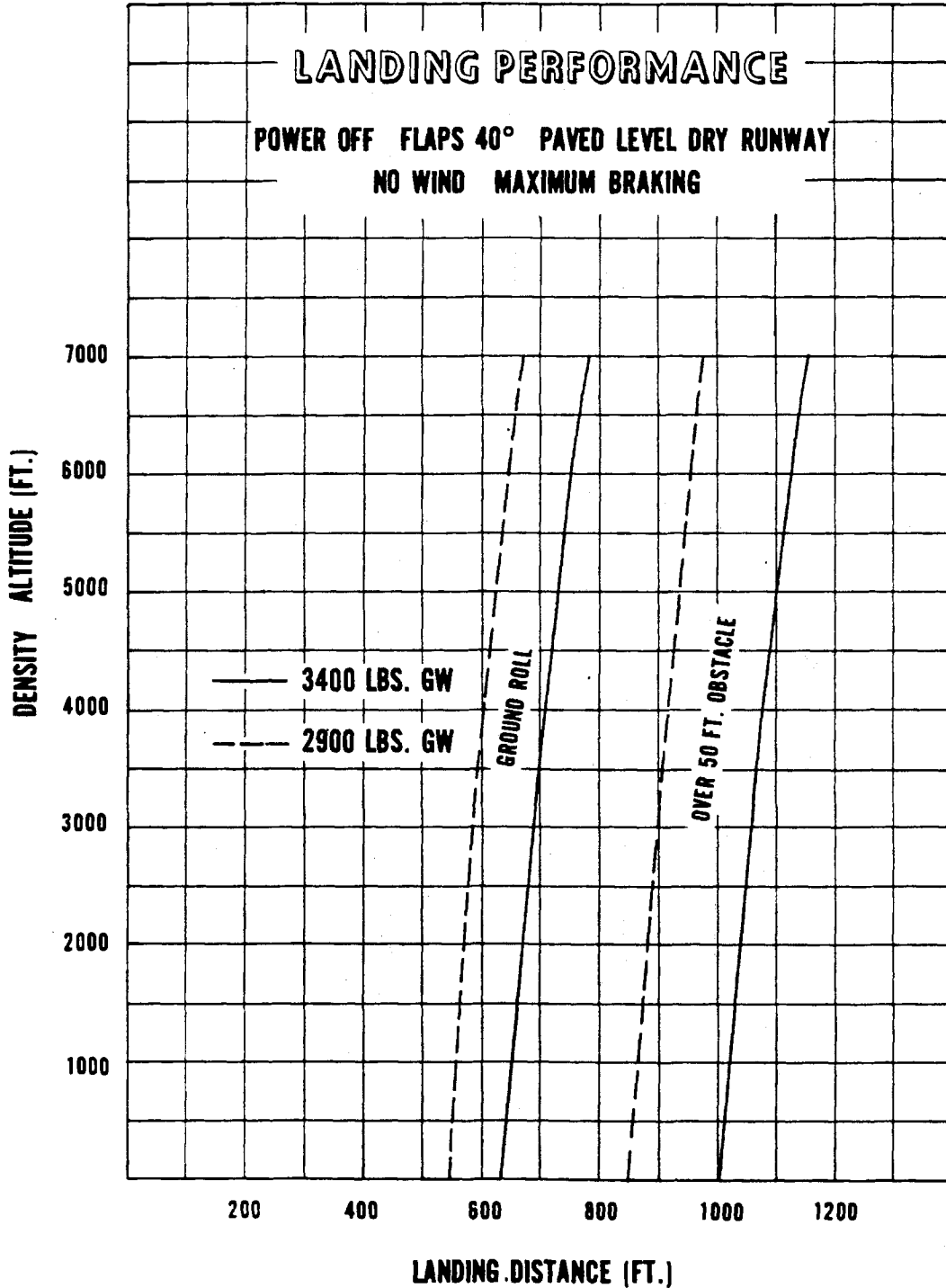

NOTE: SEE SECTION 7 FOR EFFECTS OF AIR CONDITIONING
INSTALLATION ON PERFORMANCE.

Power Setting Table - Lycoming Model IO-540-K,-L,-M Series, 300 HP Engine

761 559

Press. Alt Feet	Std Alt Temp °F	165 HP - 55% Rated RPM AND MAN. PRESS.				195 HP - 65% Rated RPM AND MAN. PRESS.				225 HP - 75% Rated RPM AND MAN. PRESS.			Press. Alt Feet
		2100	2200	2300	2400	2100	2200	2300	2400	2200	2300	2400	
SL	59	22.5	21.8	21.2	20.7	25.6	24.7	23.8	23.2	27.6	26.6	25.8	SL
1,000	55	22.3	21.6	21.0	20.5	25.3	24.4	23.5	22.9	27.3	26.3	25.5	1,000
2,000	52	22.1	21.4	20.7	20.2	25.1	24.2	23.3	22.7	27.1	26.1	25.2	2,000
3,000	48	21.9	21.2	20.5	20.0	24.8	23.9	23.0	22.5	26.8	25.8	24.9	3,000
4,000	45	21.7	21.0	20.3	19.8	24.6	23.7	22.8	22.2	26.5	25.6	24.6	4,000
5,000	41	21.5	20.8	20.1	19.6	24.3	23.5	22.5	22.0	-	25.3	24.4	5,000
6,000	38	21.3	20.6	19.8	19.3	24.0	23.2	22.3	21.7	-	25.0	24.1	6,000
7,000	34	21.0	20.4	19.6	19.1	23.7	22.9	22.0	21.5	-	-	23.8	7,000
8,000	31	20.8	20.2	19.4	18.9	-	22.5	21.8	21.2				8,000
9,000	27	20.6	20.0	19.2	18.6	-	-	21.5	21.0				9,000
10,000	23	20.4	19.8	19.0	18.4	-	-	21.2	20.7				10,000
11,000	19	20.2	19.6	18.7	18.2	-	-	-	20.4				11,000
12,000	16	20.0	19.4	18.5	18.0								12,000
13,000	12	-	19.2	18.3	17.7								13,000
14,000	9	-	-	18.0	17.3								14,000
15,000	5	-	-	-	16.9								15,000

To maintain constant power, correct manifold pressure approximately 0.18" Hg for each 10° F variation in induction air temperature from standard altitude temperature. Add manifold pressure for air temperature above standard; subtract for temperature below standard.

230 047, 670915

HANDLING AND SERVICING

Ground Handling	10-1
Towing	10-1
Taxiing	10-1
Parking	10-2
Mooring	10-2
Cleaning	10-3
Cleaning Engine Compartment	10-3
Cleaning Landing Gear	10-3
Cleaning Exterior Surfaces	10-4
Cleaning Windshield and Windows	10-4
Cleaning Headliner, Side Panels and Seats	10-4
Cleaning Carpets	10-5
Engine Air Filter	10-5
Removing Engine Air Filter	10-5
Cleaning Engine Air Filter	10-5
Installation of Engine Air Filter	10-5
Brake Service	10-5
Landing Gear Service	10-7
Propeller Service	10-8
Oil Requirements	10-8
Fuel System	10-8
Servicing Fuel System	10-8
Fuel Requirements	10-8
Filling Fuel Tanks	10-8
Draining Fuel Valves and Lines	10-9
Draining Fuel System	10-10
Tire Inflation	10-10
Battery Service	10-10
Facts You Should Know	10-10
Preventive Maintenance	10-12
Required Service and Inspection Periods	10-13

HANDLING AND SERVICING

This section contains information on preventive maintenance. Refer to the PA-32 Service Manual for further maintenance procedures. Any complex repair or modification should be accomplished by a Piper Certified Service Center.

GROUND HANDLING

TOWING

The airplane may be moved on the ground by the use of the nose wheel steering bar that is stowed below the forward ledge of the rear baggage compartment or by power equipment that will not damage or excessively strain the nose gear steering assembly. Towing lugs are incorporated as part of the nose gear forks.

CAUTION

When towing with power equipment, do not turn the nose gear beyond its steering radius in either direction, as this will result in damage to the nose gear and steering mechanism.

CAUTION

Do not tow the airplane when the controls are secured.

In the event towing lines are necessary, ropes should be attached to both main gear struts as high up on the tubes as possible. Lines should be long enough to clear the nose and/or tail by not less than fifteen feet, and a qualified person should ride in the pilot's seat to maintain control by use of the brakes.

TAXIING

Before attempting to taxi the airplane, ground personnel should be instructed and approved by a qualified person authorized by the owner. Engine starting and shut-down procedures as well as taxi techniques should be covered. When it is ascertained that the propeller back blast and taxi areas are clear, power should be applied to start the taxi roll, and the following checks should be performed:

- a. Taxi a few feet forward and apply the brakes to determine their effectiveness.
- b. Taxi with the propeller set in low pitch, high RPM setting.
- c. While taxiing, make slight turns to ascertain the effectiveness of the steering.
- d. Observe wing clearances when taxiing near buildings or other stationary objects. If possible, station an observer outside the airplane.
- e. When taxiing over uneven ground, avoid holes and ruts.
- f. Do not operate the engine at high RPM when running up or taxiing over ground containing loose stones, gravel, or any loose material that may cause damage to the propeller blades.

PARKING

When parking the airplane, be sure that it is sufficiently protected from adverse weather conditions and that it presents no danger to other aircraft. When parking the airplane for any length of time or overnight, it is suggested that it be moored securely.

- a. To park the airplane, head it into the wind if possible.
- b. Set the parking brake by pulling back on the brake lever and depressing the knob on the handle. To release the parking brake, pull back on the handle until the catch disengages; then allow the handle to swing forward.

CAUTION

Care should be taken when setting brakes that are overheated or during cold weather when accumulated moisture may freeze a brake.

- c. Aileron and stabilator controls may be secured with the front seat belt. Wheel chocks may be used if available.

MOORING

The airplane should be moored for immovability, security, and protection. The following procedures should be used for the proper mooring of the airplane:

- a. Head the airplane into the wind if possible.
- b. Retract the flaps.
- c. Immobilize the ailerons and stabilator by looping the seat belt through the control wheel and pulling it snug.
- d. Block the wheels.
- e. Secure tie-down ropes to the wing tie-down rings and to the tail skid at approximately 45 degree angles to the ground. When using rope of non-synthetic material, leave sufficient slack to avoid damage to the airplane should the ropes contract.

CAUTION

Use bowline knots, square knots or locked slip knots. Do not use plain slip knots.

NOTE

Additional preparations for high winds include using tie-down ropes from the landing gear forks and securing the rudder.

- f. Install a pitot head cover if available. Be sure to remove the pitot head cover before flight.
- g. Cabin and baggage doors should be locked when the airplane is unattended.

CLEANING

CLEANING ENGINE COMPARTMENT

Before cleaning the engine compartment, place a strip of tape on the magneto vents to prevent any solvent from entering these units.

- a. Place a large pan under the engine to catch waste.
- b. With the engine cowling removed, spray or brush the engine with solvent or a mixture of solvent and degreaser. In order to remove especially heavy dirt and grease deposits, it may be necessary to brush areas that were sprayed.

CAUTION

Do not spray solvent into the alternator, vacuum pump, starter, or air intakes.

- c. Allow the solvent to remain on the engine from five to ten minutes. Then rinse the engine clean with additional solvent and allow it to dry.

CAUTION

Do not operate the engine until excess solvent has evaporated or otherwise been removed.

- d. Remove the protective tape from the magnetos.
- e. Lubricate the controls, bearing surfaces, etc., in accordance with the Lubrication Chart.

CLEANING LANDING GEAR

Before cleaning the landing gear, place a cover of plastic or a similar waterproof material over the wheel and brake assembly.

- a. Place a pan under the gear to catch waste.
- b. Spray or brush the gear area with solvent or a mixture of solvent and degreaser. In order to remove especially heavy dirt and grease deposits, it may be necessary to brush areas that were sprayed.
- c. Allow the solvent to remain on the gear from five to ten minutes. Then rinse the gear with additional solvent and allow it to dry.
- d. Remove the cover from the wheel and remove the catch pan.
- e. Lubricate the gear in accordance with the Lubrication Chart.

CLEANING EXTERIOR SURFACES

The airplane should be washed with a mild soap and water. Harsh abrasives or alkaline soaps or detergents could make scratches on painted or plastic surfaces or could cause corrosion of metal. Cover areas where cleaning solution could cause damage. To wash the airplane, use the following procedure:

- a. Flush away loose dirt with water.
- b. Apply cleaning solution with a soft cloth, a sponge or a soft bristle brush.
- c. To remove exhaust stains, allow the solution to remain on the surface longer.
- d. To remove stubborn oil and grease, use a cloth dampened with naphtha.
- e. Rinse all surfaces thoroughly.
- f. Any good automotive wax may be used to preserve painted surfaces. Soft cleaning cloths or a chamois should be used to prevent scratches when cleaning or polishing. A heavier coating of wax on the leading surfaces will reduce the abrasion problems in these areas.

CLEANING WINDSHIELD AND WINDOWS

- a. Remove dirt, mud and other loose particles from exterior surfaces with clean water.
- b. Wash with mild soap and warm water or with aircraft plastic cleaner. Use a soft cloth or sponge in a straight back and forth motion. Do not rub harshly.
- c. Remove oil and grease with a cloth moistened with kerosene.

CAUTION

Do not use gasoline, alcohol, benzene, carbon tetrachloride, thinner, acetone, or window cleaning sprays.

- d. After cleaning plastic surfaces, apply a thin coat of hard polishing wax. Rub lightly with a soft cloth. Do not use a circular motion.
- e. A severe scratch or mar in plastic can be removed by rubbing out the scratch with jeweler's rouge. Smooth both sides and apply wax.

CLEANING HEADLINER, SIDE PANELS AND SEATS

- a. Clean headliner, side panels, and seats with a stiff bristle brush, and vacuum where necessary.
- b. Soiled upholstery, except leather, may be cleaned with a good upholstery cleaner suitable for the material. Carefully follow the manufacturer's instructions. Avoid soaking or harsh rubbing.

CAUTION

Solvent cleaners require adequate ventilation.

- c. Leather should be cleaned with saddle soap or a mild hand soap and water.

CLEANING CARPETS

To clean carpets, first remove loose dirt with a whisk broom or vacuum. For soiled spots and stubborn stains use a nonflammable dry cleaning fluid. Floor carpets may be removed and cleaned like any household carpet.

ENGINE AIR FILTER

Removing Engine Air Filter (Serial Nos. 7440001 through 7540188)

- a. Remove the top cowling.
- b. The air filter is located on the lower left side of the engine. Remove the thumb screws securing the cover. Remove the cover, then the filter.

Removing Engine Air Filter (Serial Nos. 7640001 and up)

- a. Remove the access door on left side of lower cowl.
- b. Remove the wing nuts securing the filter. Remove the filter.

Cleaning Engine Air Filter

The injector air filter must be cleaned at least once every 50 hours, and more often, even daily, when operating in dusty conditions. Extra filters are inexpensive, and a spare should be kept on hand for use as a rapid replacement.

To clean the filter:

- a. Tap the filter gently to remove dirt particles, being careful not to damage the filter. DO NOT wash the filter in any liquid. DO NOT attempt to blow out dirt with compressed air.
- b. If the filter is excessively dirty or shows any damage, replace it immediately.
- c. Wipe the filter housing with a clean cloth soaked in unleaded gasoline. When the housing is clean and dry, install the filter.

Installation Of Engine Air Filter

After cleaning or when replacing the filter, install the filter in the reverse order of removal.

BRAKE SERVICE

The brake system is filled with MIL-H-5606 (petroleum base) hydraulic brake fluid. The fluid level should be checked periodically or at every 100 hour inspection and replenished when necessary. The brake reservoir is located on the left side of the fire wall in the engine compartment. If the entire system must be refilled, fill with fluid under pressure from the brake end of the system. This will eliminate air from the system.

No adjustment of the brake clearances is necessary. If after extended service brake blocks become excessively worn, they should be replaced with new segments.

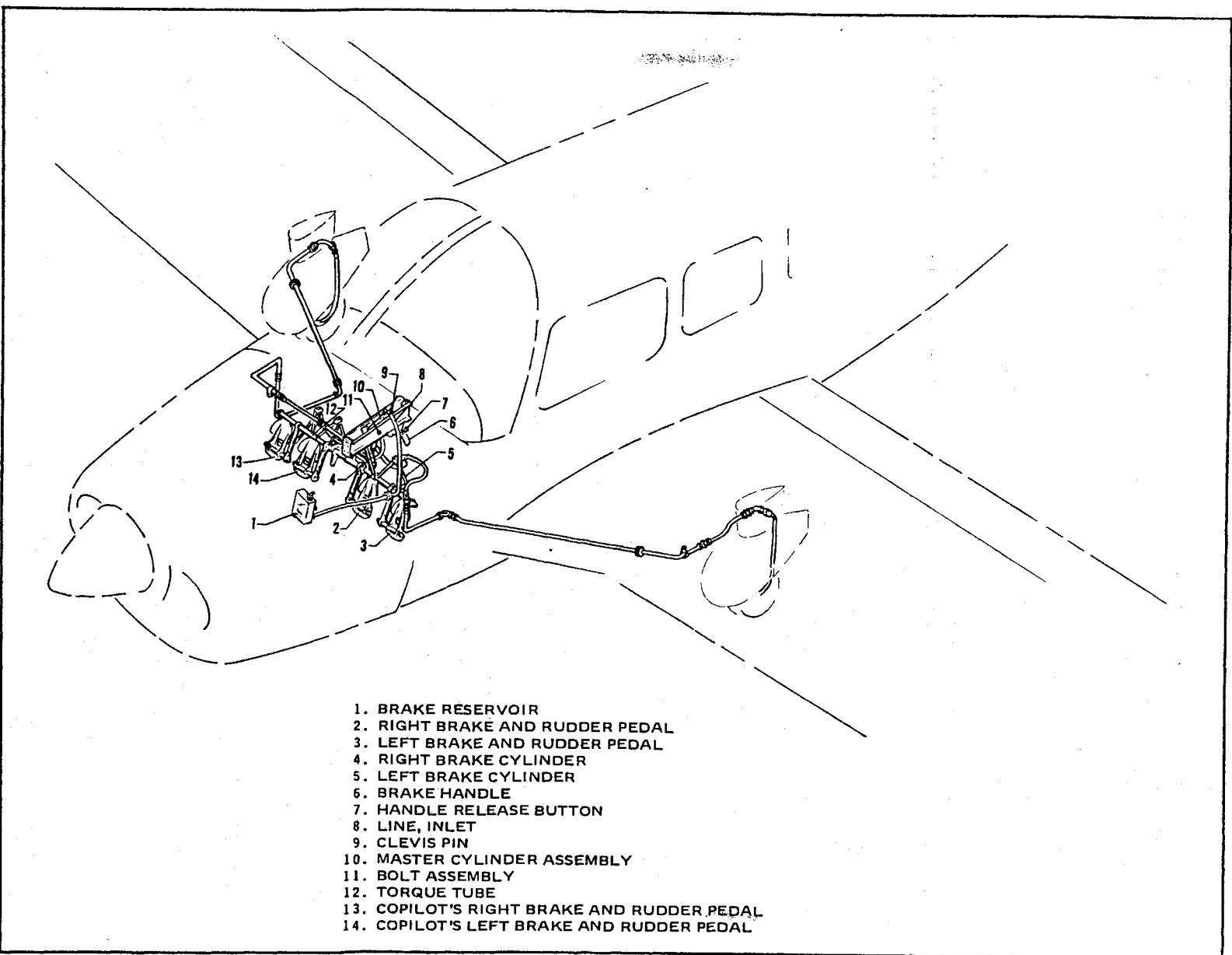

Brake System

LANDING GEAR SERVICE

The landing gears use Cleveland Aircraft Products 6.00 x 6 tube type. The main gear tires are 6 ply rating and the nose gear tire is 4 ply rating. See TIRE INFLATION, this Section.

Main wheels are removed by taking off the hub cap, axle nut and the two bolts holding the brake segment in place, after which the wheel slips easily from the axle.

The nose wheel is removed by taking off the axle nut and washer from one side, sliding out the axle rod and plugs, lightly tapping out the axle tube, and then removing the wheel and spacer tubes from between the fork. Wheels are replaced by reversing the procedure.

Tires are removed from the wheels by deflating the tire, removing the through bolts, and separating the wheel halves.

Landing gear oleo struts should be checked for proper strut exposure and visible leaks. The required extensions for the struts under normal static load (empty weight of airplane plus full fuel and oil) are 3-1/4 inches for the nose gear and 4-1/2 inches for the main gear. If the strut exposure is below that required, it should be determined whether air or oil is needed by first raising the airplane on jacks. Depress the valve core to allow air to escape from the strut housing chamber. Remove the filler plug and slowly raise the strut to full compression. If the fluid is then visible up to the bottom of the filler plug hole, only proper inflation with air is required.

If fluid is below the bottom of the filler plug hole, oil should be added. Replace the plug with the valve core removed. Then attach a clear plastic hose to the valve stem of the filler plug and submerge the free end in a container of hydraulic fluid (MIL-H-5606). Fully compress and extend the strut several times, thus drawing fluid into the strut chamber and expelling air. To allow fluid to enter the bottom chamber of the nose gear strut housing, it is necessary to disconnect the torque link assembly and allow the strut to extend a full 10 inches. (The nose gear torque links need not be disconnected.) DO NOT allow the strut to extend beyond 12 inches. When air bubbles cease to flow through the hose, fully compress the strut, remove the filler plug, and again check the fluid level. When the fluid level is correct, disconnect the hose, reinstall the valve core, the filler plug, and the main gear torque links.

With the fluid in the strut housing at the proper level, attach a strut pump to the air valve. With the airplane on the ground under normal static load, inflate the oleo strut to the proper strut exposure.

In jacking the airplane for landing gear or other service, two hydraulic jacks and a tail stand should be used. At least 350 pounds of ballast should be placed on the base of the tail stand before jacking up the airplane. The hydraulic jacks are placed under the jack points on the underside of the wings, and the airplane is jacked up until the tail stand can be attached to the tail skid. After attaching the tail stand and adding ballast, the jacking can be continued until the airplane is at the desired height.

PROPELLER SERVICE

The spinner and backing plate should be cleaned and inspected for cracks frequently. Before each flight the propeller should be inspected for nicks, scratches, and corrosion. If found, they should be repaired as soon as possible by a rated mechanic, since a nick or scratch causes an area of increased stress which can lead to serious cracks or the loss of a propeller tip. The back face of the blades should be painted when necessary with flat black paint to retard glare. To prevent corrosion, the surface should be cleaned and waxed periodically.

OIL REQUIREMENTS

The oil capacity of the Lycoming IO-540 series engine is 12 quarts, and the minimum safe quantity is 2-3/4 quarts. It is recommended that the oil be changed every 50 hours and sooner under unfavorable operating conditions. The following grades are recommended for the specified temperatures:

TEMPERATURE	GRADE
Temperatures above 60° F	S.A.E. 50
Temperatures between 30° F and 90° F	S.A.E. 40
Temperatures between 0° F and 70° F	S.A.E. 30
Temperatures below 10° F	S.A.E. 20

FUEL SYSTEM

SERVICING FUEL SYSTEM

At every 50 hour inspection, the fuel screens in the strainer and in the injector must be cleaned. The screen in the injector is located in the housing where the fuel line connects to the injector. The fuel strainer is located under the floor panel and is accessible for cleaning through an access plate on the underside of the fuselage. After cleaning, a small amount of grease applied to the gasket will facilitate reassembly.

FUEL REQUIREMENTS

Aviation grade fuel with a minimum octane of 100/130 must be used in this airplane. Since the use of lower grades can cause serious engine damage in a short period of time, the engine warranty is invalidated by the use of lower octanes.

FILLING FUEL TANKS

Observe all safety precautions required when handling gasoline. Fill the fuel tanks through the filler located on the forward slope of the wings and on the wing tips. Each wing tank holds a maximum of 25 U.S. gallons, and each wing tip tank holds a maximum of 17 U.S. gallons. When using less than the standard 84 gallon capacity, fuel should be distributed equally between each side, with the wing tip tanks filled first.

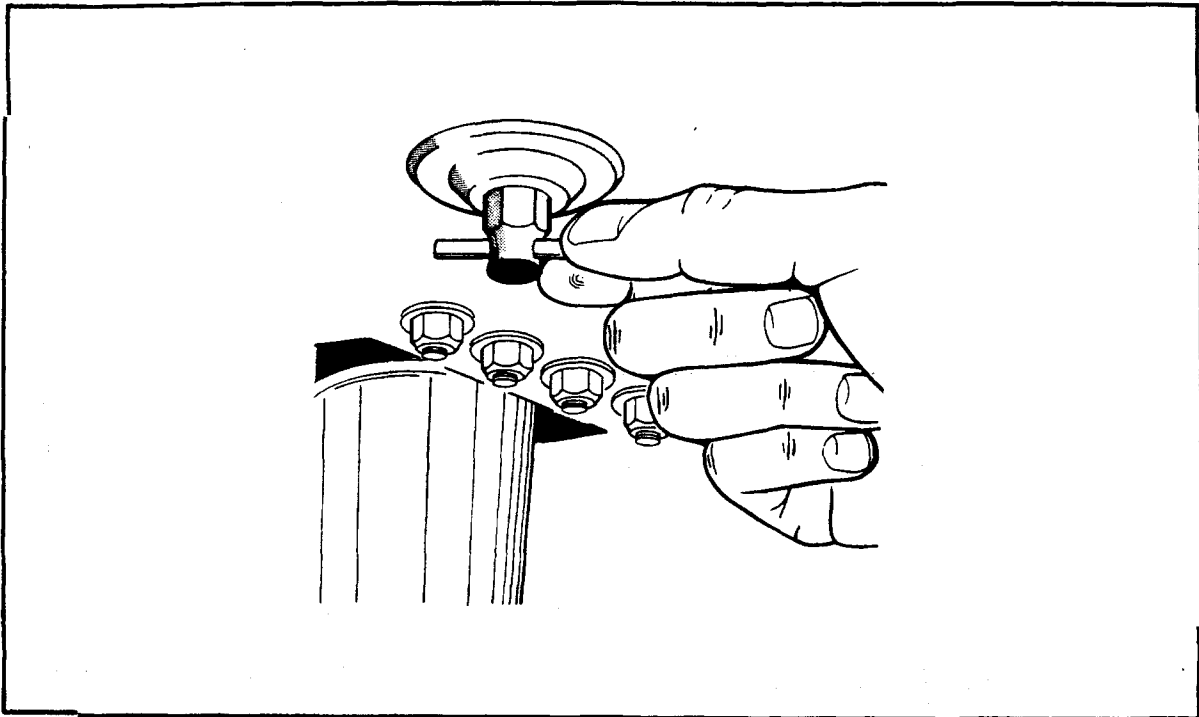

Fuel Drain

DRAINING FUEL VALVES AND LINES

The fuel system should be drained before the first flight of the day and after refueling to avoid the accumulation of water and sediment. Each fuel tank has an individual quick drain at the lower inboard corner. A fuel strainer with a fuel system quick drain is located at the lowest point in the system. Each tank should be drained through its individual quick drain until sufficient fuel has flowed to ensure the removal of any contaminants. The fuel system quick drain, operated by a lever inside the cabin on the right forward edge of the wing spar housing, should be opened while the fuel selector valve is moved through the four different tank positions. Enough fuel should flow at each position to allow the fuel lines and the strainer to clear. A container is provided for the checking of fuel clarity. (See Description - Airplane and Systems Section for more detailed instructions.)

CAUTION

When draining fuel, be sure that no fire hazard exists before starting the engine.

After using the fuel system quick drain, check from outside the airplane to be sure that it has closed completely and is not leaking.

DRAINING FUEL SYSTEM

The bulk of the fuel may be drained by opening the individual drain on each tank. The remaining fuel may be drained through the fuel strainer. Any individual tank may be drained by closing the fuel selector valve and then draining the desired tank.

TIRE INFLATION

For maximum service from the tires, keep them inflated to the proper pressures – 28-30 psi for the nose gear and 35-40 psi for the main gear. All wheels and tires are balanced before original installation, and the relationship of tire, tube, and wheel should be maintained upon reinstallation. Unbalanced wheels can cause extreme vibration in the landing gear; therefore, in the installation of new components, it may be necessary to rebalance the wheels with the tires mounted. When checking tire pressure, examine the tires for wear, cuts, bruises, and slippage.

BATTERY SERVICE

Access to the 12-volt battery is through a removable panel in the floor of the forward baggage compartment. The battery box has a plastic tube which is normally closed off with a cap and which should be opened occasionally to drain off any accumulation of liquid. The battery should be checked for proper fluid level. **DO NOT** fill the battery above the baffle plates. **DO NOT** fill the battery with acid - use water only. A hydrometer check will determine the percent of charge in the battery.

If the battery is not up to charge, recharge starting at a 4 amp rate and finishing with a 2 amp rate. Quick charges are not recommended.

FACTS YOU SHOULD KNOW

The Federal Aviation Administration (FAA) occasionally publishes **Airworthiness Directives (ADs)** that apply to specific groups of aircraft. They are mandatory changes and are to be complied with within a time limit set by the FAA. When an AD is issued, it is sent to the latest registered owner of the affected aircraft and also to subscribers of the service. The owner should periodically check with his Piper dealer or A & P mechanic to see whether he has the latest issued AD against his aircraft.

Piper Aircraft Corporation takes a **continuing interest** in having the owner get the most efficient use from his aircraft and keeping it in the best mechanical condition. Consequently, Piper Aircraft from time to time issues Service Bulletins, Service Letters and Service Spares Letters relating to the aircraft.

Service Bulletins are of special importance and should be complied with promptly. These are sent to the latest registered owners, distributors and dealers. Depending on the nature of the bulletin, material and labor allowances are usually applicable.

Service Letters deal with product improvements and service hints pertaining to the aircraft. They are sent to dealers and distributors so they can properly service the aircraft and keep it up to date with the latest changes. Owners should give careful attention to the Service Letter information.

Service Spares Letters offer improved parts, kits and optional equipment which were not available originally and which may be of interest to the owner.

If an owner is not having his aircraft serviced by an Authorized Piper Service Center, he should periodically check with a Piper dealer or distributor to find out the latest information to keep his aircraft up to date.

Piper Aircraft Corporation has a **Subscription Service** for the Service Bulletins, Service Letters and Service Spares Letters. This service is offered to interested persons such as owners, pilots and mechanics at a nominal fee, and may be obtained through Piper dealers and distributors. A Service Manual and revisions are available from a Piper dealer.

Pilot's Operating Manual supplements are distributed by the manufacturer as necessary. These revisions and additions should be studied and put into the operating manual to keep it up to date. This manual contains important information about the operation of the aircraft and should be kept with the aircraft at all times, even after resale. Every owner, to avail himself of the Piper Aircraft Service Back-Up, should stay in close contact with his Piper dealer or distributor so that he can receive the latest information.

If the owner desires to have his aircraft modified, he must obtain FAA approval for the alteration. **Major alterations** accomplished in accordance with Advisory Circular 43.13-2, when performed by an A & P mechanic, may be approved by the local FAA office. Major alterations to the basic airframe or systems not covered by AC 43.13-2 require a Supplemental Type Certificate.

The owner or pilot is required to ascertain that the following **Aircraft Papers** are in order and in the aircraft.

- a. To be displayed in the aircraft at all times:
 1. Aircraft Airworthiness Certificate Form FAA-1362B.
 2. Aircraft Registration Certificate Form FAA-500A.
 3. Aircraft Radio Station License Form FCC-404A, if transmitters are installed.
- b. To be carried in the aircraft at all times:
 1. Aircraft Flight Manual.
 2. Weight and Balance data plus a copy of the latest Repair and Alteration Form FAA-337, if applicable.
 3. Aircraft equipment list.

Although the aircraft and engine log books are not required to be in the aircraft, they should be made available upon request. Log books should be complete and up to date. Good records will reduce maintenance cost by giving the mechanic information about what has or has not been accomplished.

PREVENTIVE MAINTENANCE

The holder of a Pilot Certificate issued under FAR Part 61 may perform certain preventive maintenance described in FAR Part 43. This maintenance may be performed only on an aircraft which the pilot owns or operates and which is not used in air carrier service. The following is a list of the maintenance which the pilot may perform:

1. Repair or change tires and tubes.
2. Service landing gear wheel bearings, such as cleaning, greasing or replacing.
3. Service landing gear shock struts by adding air, oil or both.
4. Replace defective safety wire and cotter keys.
5. Lubrication not requiring disassembly other than removal of non-structural items such as cover plates, cowling or fairings.
6. Replenish hydraulic fluid in the hydraulic reservoirs.
7. Refinish the exterior or interior of the aircraft (excluding balanced control surfaces) when removal or disassembly of any primary structure or operating system is not required.
8. Replace side windows and safety belts.
9. Replace seats or seat parts with replacement parts approved for the aircraft.
10. Replace bulbs, reflectors and lenses of position and landing lights.
11. Replace cowling not requiring removal of the propeller.
12. Replace, clean or set spark plug clearance.
13. Replace any hose connection, except hydraulic connections, with replacement hoses.
14. Replace pre-fabricated fuel lines.
15. Replace the battery and check fluid level and specific gravity.

Although the above work is allowed by law, each individual should make a self analysis as to whether he has the ability to perform the work.

If the above work is accomplished, an entry must be made in the appropriate log book. The entry should contain:

1. The date the work was accomplished.
2. Description of the work.
3. Number of hours on the aircraft.
4. The certificate number of pilot performing the work.
5. Signature of the individual doing the work.

REQUIRED SERVICE AND INSPECTION PERIODS

Piper Aircraft Corporation provides for the initial and first 50-hour inspection, at no charge to the owner. The **Owner Service Agreement** which the owner receives upon delivery of the aircraft should be kept in the aircraft at all times. This identifies him to authorized Piper dealers and entitles the owner to receive service in accordance with the regular service agreement terms. This agreement also entitles the transient owner full warranty by any Piper dealer in the world.

One hundred hour inspections are required by law if the aircraft is used commercially. Otherwise this inspection is left to the discretion of the owner. This inspection is a complete check of the aircraft and its systems, and should be accomplished by a Piper Authorized Service Center or by a qualified aircraft and power plant mechanic who owns or works for a reputable repair shop. The inspection is listed, in detail, in the inspection report of the appropriate Service Manual.

An **annual inspection** is required once a year to keep the Airworthiness Certificate in effect. It is the same as a 100-hour inspection except that it must be signed by an Inspection Authorized (IA) mechanic or a General Aviation District Office (GADO) representative. This inspection is required whether the aircraft is operated commercially or for pleasure.

A **Progressive Maintenance** program is approved by the FAA and is available to the owner. It involves routine and detailed inspections at 50-hour intervals. The purpose of the program is to allow maximum utilization of the aircraft, to reduce maintenance inspection cost and to maintain a maximum standard of continuous airworthiness. Complete details are available from Piper dealers.

A **spectographic analysis** of the oil is available from several sources. This system, if used intelligently, provides a good check of the internal condition of the engine. For this system to be accurate, oil samples must be sent in at regular intervals, and induction air filters must be cleaned or changed regularly.

TYPE OF LUBRICANTS			SPECIAL INSTRUCTIONS	
IDENTIFICATION LETTER	LUBRICANT	SPECIFICATION	PREFERRED PRODUCT AND VENDOR	
A	LUBRICATING OIL, GENERAL PURPOSE, LOW TEMP.	MIL-L-7870		1. AIR FILTER - TO CLEAN FILTER, TAP GENTLY TO REMOVE DIRT PARTICLES. DO NOT BLOW OUT WITH COMPRESSED AIR OR USE OIL. REPLACE FILTER IF PUNCTURED OR DAMAGED.
B	LUBRICATING OIL, AIRCRAFT RECIPROCATING ENGINE (PISTON) GRADE AS SPECIFIED SAE 50 ABOVE 60°F AIR TEMP. SAE 40 30° TO 90°F AIR TEMP. SAE 30 0° TO 70°F AIR TEMP. SAE 20 BELOW 10°F AIR TEMP.	MIL-L-6082		2. BEARINGS AND BUSHINGS - CLEAN EXTERIOR WITH A DRY TYPE SOLVENT BEFORE LUBRICATING.
C	HYDRAULIC FLUID, PETROLEUM BASE	MIL-H-5606		3. WHEEL BEARINGS - DISASSEMBLE AND CLEAN WITH A DRY TYPE SOLVENT. ASCERTAIN THAT GREASE IS PACKED BETWEEN THE BEARING ROLLER AND CONE. DO NOT PACK GREASE IN WHEEL HOUSING.
D	GREASE, AIRCRAFT AND INSTRUMENT, GEAR AND ACTUATOR SCREW	MIL-G-23827		4. OLEO STRUTS, HYDRAULIC PUMP RESERVOIR AND BRAKE RESERVOIR - FILL PER INSTRUCTIONS ON UNIT OR CONTAINER, OR REFER TO SERVICE MANUAL, SECTION II.
E	GREASE, AIRCRAFT, HIGH TEMP.		TEXACO MARRAK ALL PURPOSE GREASE, MOBIL GREASE 77 (OR MOBILUX EP2), SHELL ALVANIA EP GREASE 2	5. PROPELLER - REMOVE ONE OF THE TWO GREASE FITTINGS FOR EACH BLADE. APPLY GREASE THROUGH FITTING UNTIL FRESH GREASE APPEARS AT HOLE OF REMOVED FITTING.
F	GREASE, LUBRICATION, GENERAL PURPOSE, AIRCRAFT	MIL-G-7711		6. LUBRICATION POINTS - WIPE ALL LUBRICATION POINTS CLEAN OF OLD GREASE, OIL, DIRT, ETC. BEFORE LUBRICATING.
G	PARKER O-RING LUBRICANT			7. INTERVALS BETWEEN OIL CHANGES CAN BE INCREASED AS MUCH AS 100% ON ENGINES EQUIPPED WITH FULL FLOW (CARTRIDGE TYPE) OIL FILTERS - PROVIDED THE ELEMENT IS REPLACED EACH 50 HOURS OF OPERATION.
H	AERO LUBRIPLATE		FISKE BROS. REFINING CO.	8. FUEL SELECTOR VALVE - LUBRICATE AREA WHERE DETENT BALL MOVES ACROSS COVER PLATE.
I	FLUOROCARBON RELEASE AGENT DRY LUBRICANT	#MS-122		9. O-RING, CONTROL SHAFT BUSHING - DISASSEMBLE O-RING RETAINER PLATES FROM INSTRUMENT PANEL, LUBRICATE O-RING AND REASSEMBLE.
				10. AILERON HINGES WITH TEFLON SLEEVES SHOULD NOT BE LUBRICATED. AILERON HINGES WITHOUT TEFLON SLEEVES SHOULD FIRST BE CLEANED WITH A DRY TYPE SOLVENT THEN LUBRICATED WITH MIL-L-7870 LUBRICATING OIL.
				11. THIS TRANSMISSION TO BE 1/2 FULL OF GREASE. APPLY GREASE DURING ASSEMBLY AND LUBRICATE TRANSMISSION BALL NUT AND SCREW WITH MIL-G-23827 GREASE.
				12. APPLY FLUOROCARBON DRY LUBRICANT TO DOOR SEALS AT LEAST ONCE A MONTH TO PREVENT THE SEAL FROM STICKING, AND IMPROVE SEALING CHARACTERISTICS.

EXAMPLE

NOTES

1. PILOT AND PASSENGER SEATS - LUBRICATE TRACK ROLLERS AND STOP PINS AS REQUIRED. (TYPE OF LUBRICANT: "A")
2. WHEEL BEARINGS REQUIRE CLEANING AND REPACKING AFTER EXPOSURE TO AN ABNORMAL QUANTITY OF WATER.
3. FUEL SELECTOR VALVE - LUBRICATE FUEL SELECTOR VALVE AS REQUIRED, REFER TO PIPER SERVICE LETTER NO. 351.
4. SEE LYCOMING SERVICE INSTRUCTIONS NO. 1014 FOR USE OF DETERGENT OIL.

CAUTIONS

1. DO NOT USE HYDRAULIC FLUID WITH A CASTOR OIL OR ESTER BASE.
2. DO NOT OVER-LUBRICATE COCKPIT CONTROLS.
3. DO NOT APPLY LUBRICANT TO RUBBER PARTS.

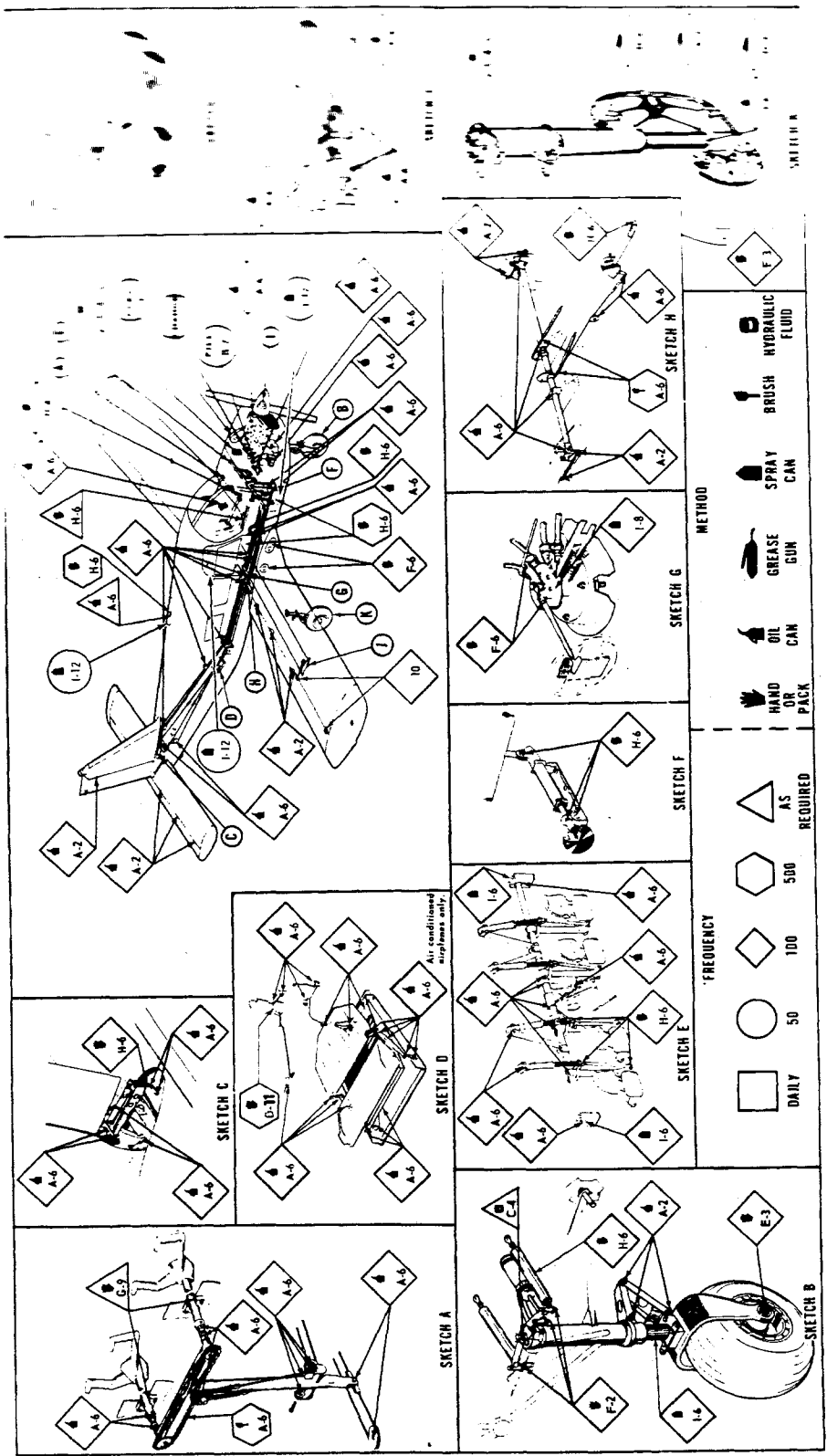

Lubrication Chart

BERLIN AVIONICS
 3165 DONALD DOUGLAS LOOP S
 SANTA MONICA, CA. 90405
 FAA REPAIR STATION Ebur109k

WEIGHT AND BALANCE REPORT *** REVISED EQUIPMENT LIST

 Aircraft Type ----- : PIPER
 Aircraft Model ----- : PA32-300
 Aircraft S/N ----- : 32-7440074
 Aircraft Registration -- : N7801A
 Maximum Gross Weight --- : 3400 LBS

Revised weight and balance computations are based on previous data dated 02/19/04.

	WEIGHT (LBS)	ARM (IN)	MOMENT (IN/LBS)
PREVIOUS EMPTY WEIGHT <<< CORRECTED >>>	2074.5	74.88	155334.50
PREVIOUS USEFUL LOAD <<< CORRECTED >>>	1325.5		

* EQUIPMENT REMOVED *

Model	Serial #	Description			
KX 155	U37703	KING COM/NAV	5.0	69.5	347.50
KI-209	53079	KING VOR/LOC	1.0	71.0	71.00
TNI 1000	4323230	TRIMBLE GPS	1.9	69.5	132.05

* EQUIPMENT ADDED *

Model	Serial #	Description			
GI 106A	B0510706	GARMIN VOR/LOC	1.5	72.0	108.00
GNS 430	97126116	GAR GPS/COM/NAV	6.5	69.5	451.75
GA 56	59404427	GARMIN ANTENNA	0.5	59.0	29.50

NEW EMPTY WEIGHT <<< CURRENT >>>	2075.1	74.88	155373.20
NEW USEFUL LOAD <<< CURRENT >>>	1324.9		
MAXIMUM GROSS WEIGHT	3400.0		