



SOUTH SHORE PHRF HANDICAP CERTIFICATE 2026

PHRF-SS, LLC., PO Box 347021, Cleveland, OH 44134

<http://phrfss.org>

HCP (Spinnaker): -21 sec/nm
NSP (Non-Spinnaker): -12 sec/nm
PPF (Perf Prediction Factor): 5.36
TCF (Time Correction Factor): 1.2832
CRWT (Crew Weight Limit): 3109 LBS.

YACHT NAME: EAGLE
DESIGN: HINCKLEY BRM 50
OWNER: Dave Banyard
CERTIFICATE: PRLM
CLASSIFICATION: DISP
SAIL NO: 50015
POWER: IB
YACHT CLUB: VYC

LOA: 49.74 FT.
LWL: 45.20 FT.
BEAM: 14 FT.
DRAFT: 11.70 FT.
DISPLACEMENT: 28000 LBS.
BALLAST: 7495 LBS.
SAIL AREA: 1455 SQ. FT.
THS: 9.01 KN.

I: 70.21 FT.
ISP: 75.71 FT.
J: 19.62 FT.
JSP/TPS: 25.41 FT.
P: 69.00 FT.
E: 22.21 FT.

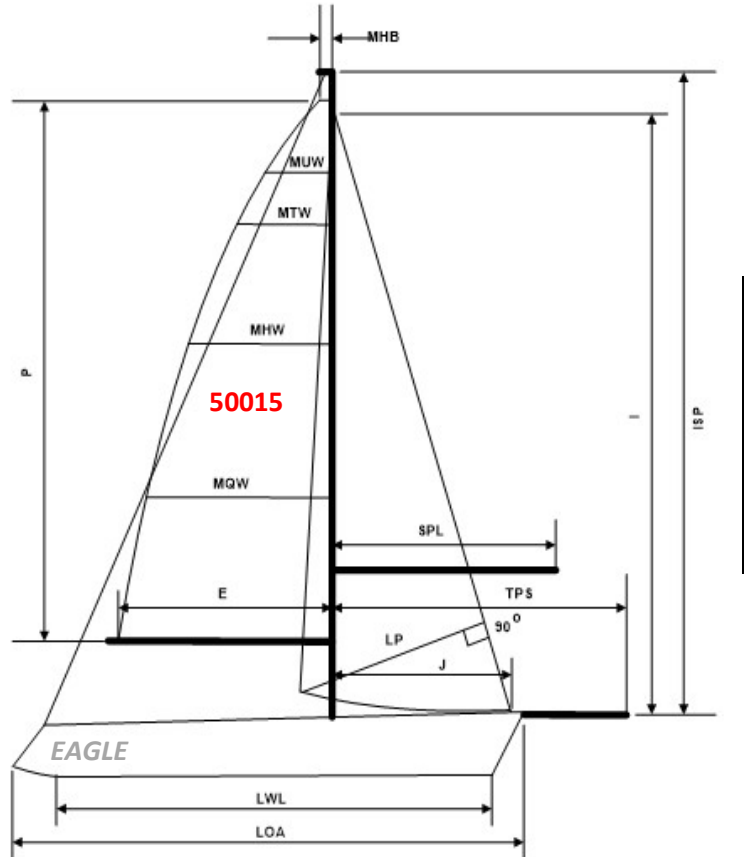

HANDICAP ADJUSTMENTS

+3 BOW THRUST

Adjustments must be requested by the owner and are only made based on visual inspection and/or physical measurement by an authorized PHRF-SS measurer.

Owner Signature: _____

My signature attests to the fact that all the information contained on this certificate is true and correct to the best of my knowledge and that I have not made any modifications to the boat which have not been reported to PHRF-SS.

Certificate Issue: 5/31/2026

Certificate Expires: 3/31/2027



SOUTH SHORE PHRF HANDICAP CERTIFICATE 2026

PHRF-SS, LLC., PO Box 347021, Cleveland, OH 44134

<http://phrfss.org>

HCP (Spinnaker): 72 sec/nm
NSP (Non-Spinnaker): 81 sec/nm
PPF (Perf Prediction Factor): 6.70
TCF (Time Correction Factor): 1.0882
CRWT (Crew Weight Limit): 2201 LBS.

YACHT NAME: OUTLET XPRESS
DESIGN: EXPRESS 37
OWNER: Ken Block
CERTIFICATE: **STND**
CLASSIFICATION: DISP
SAIL NO: 41046
POWER: IB
YACHT CLUB: EWYC

LOA: 37.08 FT.
LWL: 30.83 FT.
BEAM: 11.50 FT.
DRAFT: 7.25 FT.
DISPLACEMENT: 9800 LBS.
BALLAST: 4600 LBS.
SAIL AREA: 638 SQ. FT.
THS: 7.44 KN.

I: 48.75 FT.
ISP: 48.75 FT.
J: 14.33 FT.
JSP/TPS: 14.33 FT.
P: 42.00 FT.
E: 13.75 FT.

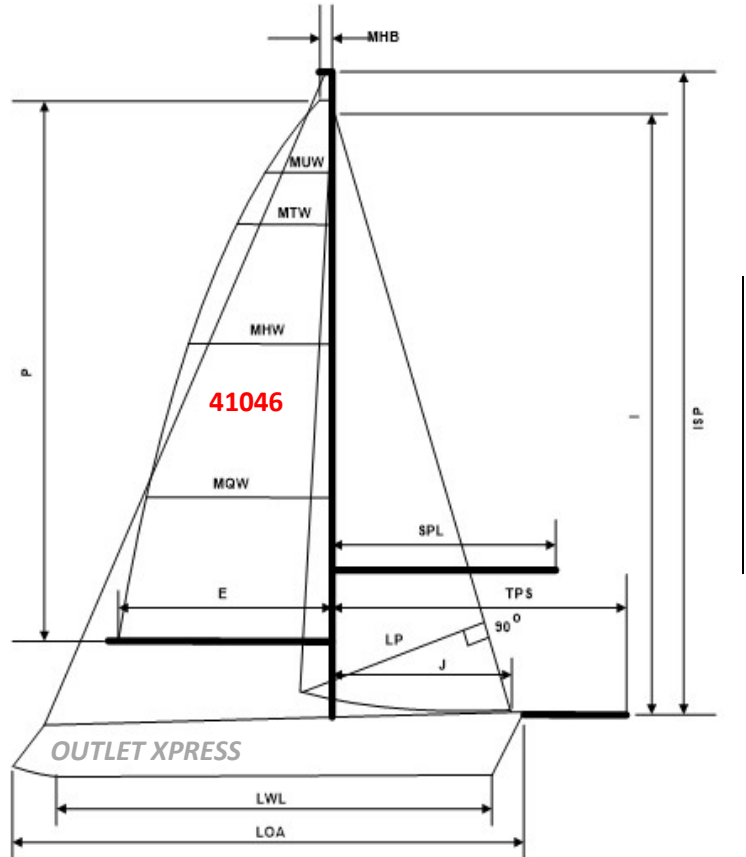

HANDICAP ADJUSTMENTS

Adjustments must be requested by the owner and are only made based on visual inspection and/or physical measurement by an authorized PHRF-SS measurer.

Owner Signature: _____

My signature attests to the fact that all the information contained on this certificate is true and correct to the best of my knowledge and that I have not made any modifications to the boat which have not been reported to PHRF-SS.

Certificate Issue: 3/1/2026

Certificate Expires: 3/31/2027



SOUTH SHORE PHRF HANDICAP CERTIFICATE 2026

PHRF-SS, LLC., PO Box 347021, Cleveland, OH 44134

<http://phrfss.org>

HCP (Spinnaker): 150 sec/nm
NSP (Non-Spinnaker): 156 sec/nm
PPF (Perf Prediction Factor): 9.61
TCF (Time Correction Factor): 0.9652
CRWT (Crew Weight Limit): 1763 LBS.

YACHT NAME: SOLIDARITY
DESIGN: J-30
OWNER: Paul Blonski
CERTIFICATE: **STND**
CLASSIFICATION: DISP
SAIL NO: 84
POWER: IB
YACHT CLUB: EWYC

LOA: 30 FT.
LWL: 25 FT.
BEAM: 11 FT.
DRAFT: 5.25 FT.
DISPLACEMENT: 6700 LBS.
BALLAST: 2100 LBS.
SAIL AREA: 443 SQ. FT.
THS: 6.70 KN.

I: 34.00 FT.
ISP: 34.19 FT.
J: 11.50 FT.
JSP/TPS: 12.50 FT.
P: 38.00 FT.
E: 13.00 FT.

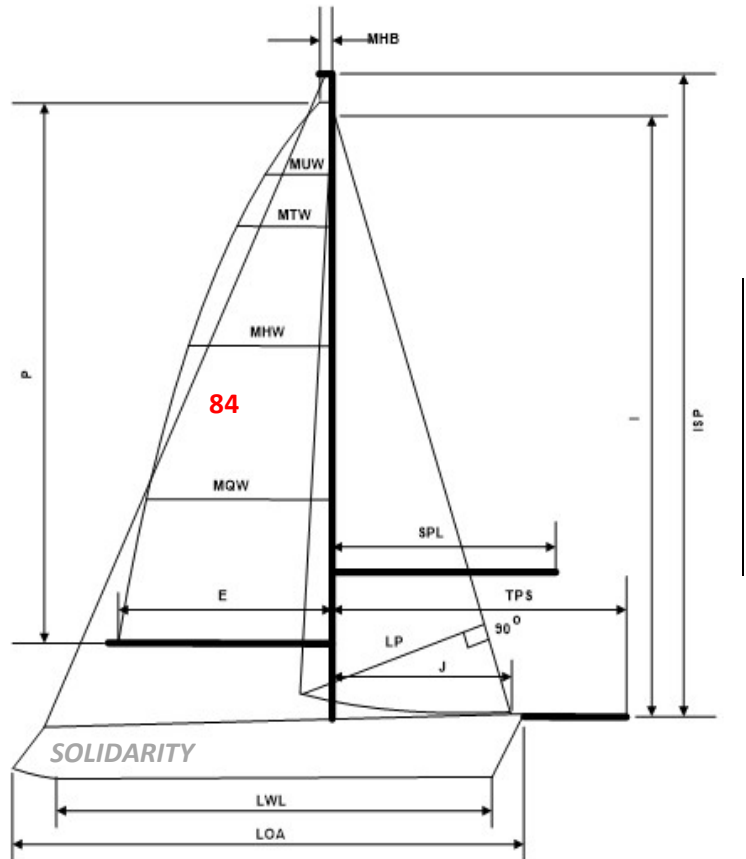

HANDICAP ADJUSTMENTS

+3 RFG

Adjustments must be requested by the owner and are only made based on visual inspection and/or physical measurement by an authorized PHRF-SS measurer.

Owner Signature: _____

My signature attests to the fact that all the information contained on this certificate is true and correct to the best of my knowledge and that I have not made any modifications to the boat which have not been reported to PHRF-SS.

Certificate Issue: 3/1/2026

Certificate Expires: 3/31/2027



SOUTH SHORE PHRF HANDICAP CERTIFICATE 2026

PHRF-SS, LLC., PO Box 347021, Cleveland, OH 44134

<http://phrfss.org>

HCP (Spinnaker): 96 sec/nm
NSP (Non-Spinnaker): 104 sec/nm
PPF (Perf Prediction Factor): 11.47
TCF (Time Correction Factor): 1.0472
CRWT (Crew Weight Limit): 2384 LBS.

YACHT NAME: VOYAGER
DESIGN: TARTAN 4100 TM SD
OWNER: Hunter Chisholm
CERTIFICATE: **STND**
CLASSIFICATION: DISP
SAIL NO: 4100
POWER: IB
YACHT CLUB: LYC

LOA: 41 FT.
LWL: 36 FT.
BEAM: 14 FT.
DRAFT: 5.33 FT.
DISPLACEMENT: 20400 LBS.
BALLAST: 8000 LBS.
SAIL AREA: 811 SQ. FT.
THS: 8.01 KN.

I: 54.00 FT.
ISP: 54.00 FT.
J: 15.00 FT.
JSP/TPS: 15.00 FT.
P: 47.75 FT.
E: 17.00 FT.

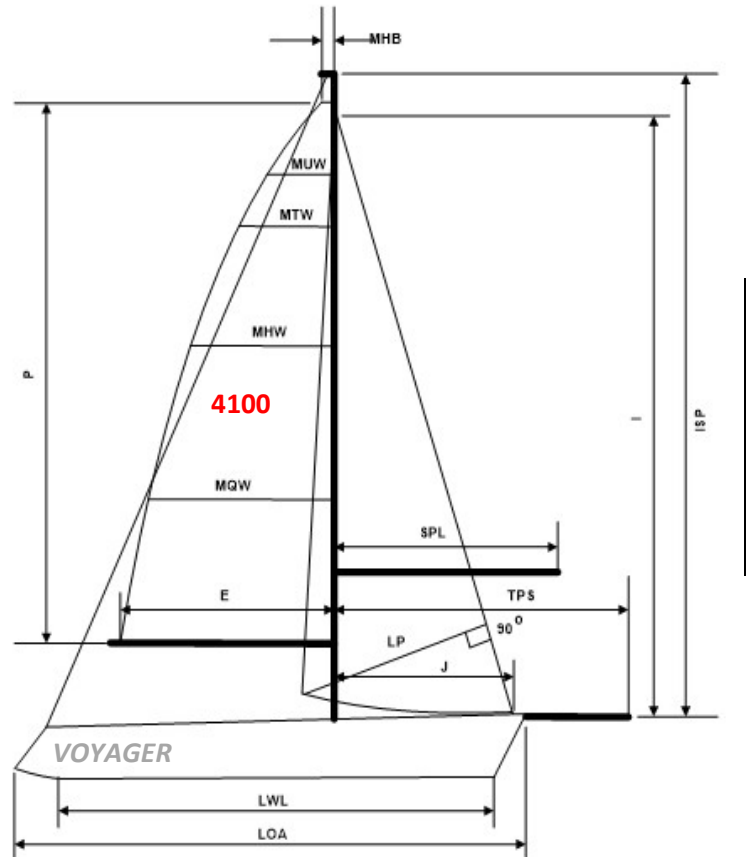

HANDICAP ADJUSTMENTS

+3 RFG

Adjustments must be requested by the owner and are only made based on visual inspection and/or physical measurement by an authorized PHRF-SS measurer.

Owner Signature: _____

My signature attests to the fact that all the information contained on this certificate is true and correct to the best of my knowledge and that I have not made any modifications to the boat which have not been reported to PHRF-SS.

Certificate Issue: 3/5/2026

Certificate Expires: 3/31/2027



SOUTH SHORE PHRF HANDICAP CERTIFICATE 2026

PHRF-SS, LLC., PO Box 347021, Cleveland, OH 44134

<http://phrfss.org>

HCP (Spinnaker): 225 sec/nm
NSP (Non-Spinnaker): 235 sec/nm
PPF (Perf Prediction Factor): 10.22
TCF (Time Correction Factor): 0.8706
CRWT (Crew Weight Limit): 1430 LBS.

YACHT NAME: MYSTICAL
DESIGN: CAL 25-2 OB
OWNER: Colahan-Sederstrom
CERTIFICATE: STND
CLASSIFICATION: DISP
SAIL NO: 1668
POWER: OB
YACHT CLUB: EWYC

LOA: 25 FT.
LWL: 22 FT.
BEAM: 9 FT.
DRAFT: 4.50 FT.
DISPLACEMENT: 4500 LBS.
BALLAST: 2000 LBS.
SAIL AREA: 315 SQ. FT.
THS: 6.29 KN.

I: 33.00 FT.
ISP: 33.00 FT.
J: 11.00 FT.
JSP/TPS: 11.00 FT.
P: 28.00 FT.
E: 9.50 FT.

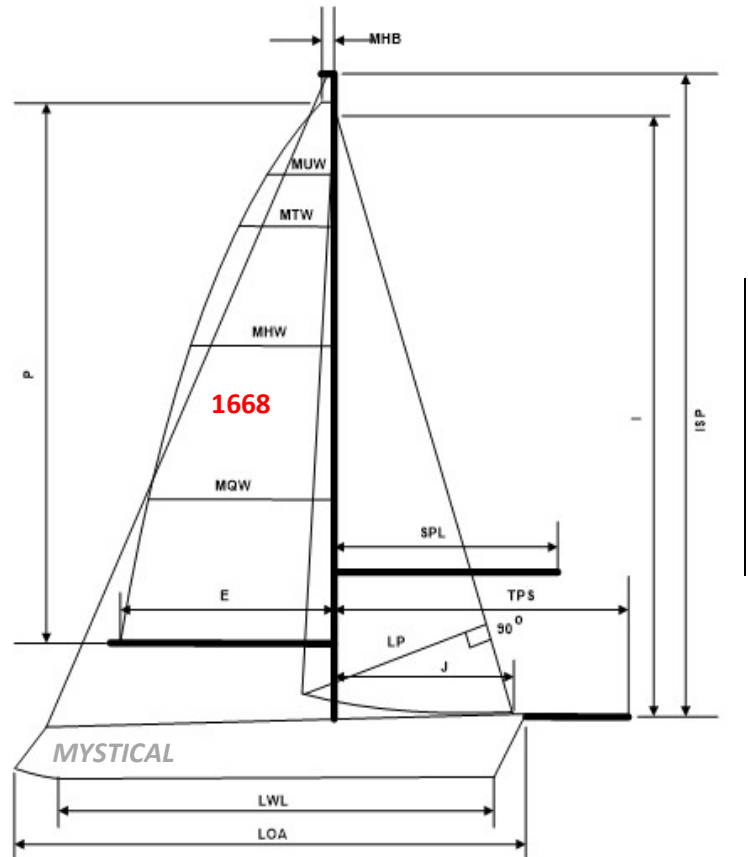

HANDICAP ADJUSTMENTS

Adjustments must be requested by the owner and are only made based on visual inspection and/or physical measurement by an authorized PHRF-SS measurer.

Owner Signature: _____

My signature attests to the fact that all the information contained on this certificate is true and correct to the best of my knowledge and that I have not made any modifications to the boat which have not been reported to PHRF-SS.

Certificate Issue: 6/17/2026

Certificate Expires: 3/31/2027



SOUTH SHORE PHRF HANDICAP CERTIFICATE 2026

PHRF-SS, LLC., PO Box 347021, Cleveland, OH 44134

<http://phrfss.org>

HCP (Spinnaker): 141 sec/nm
NSP (Non-Spinnaker): 150 sec/nm
PPF (Perf Prediction Factor): 10.71
TCF (Time Correction Factor): 0.9780
CRWT (Crew Weight Limit): 2025 LBS.

YACHT NAME: CAN'T CONTAIN'ER
DESIGN: TARTAN 3500 SD BT
OWNER: Jane Colazzo
CERTIFICATE: **STND**
CLASSIFICATION: DISP
SAIL NO: 91
POWER: IB
YACHT CLUB: EWYC

LOA: 35 FT.
LWL: 30 FT.
BEAM: 12 FT.
DRAFT: 4.83 FT.
DISPLACEMENT: 12100 LBS.
BALLAST: 4900 LBS.
SAIL AREA: 615 SQ. FT.
THS: 7.34 KN.

I: 46.75 FT.
ISP: 46.75 FT.
J: 13.75 FT.
JSP/TPS: 14.75 FT.
P: 41.25 FT.
E: 14.25 FT.

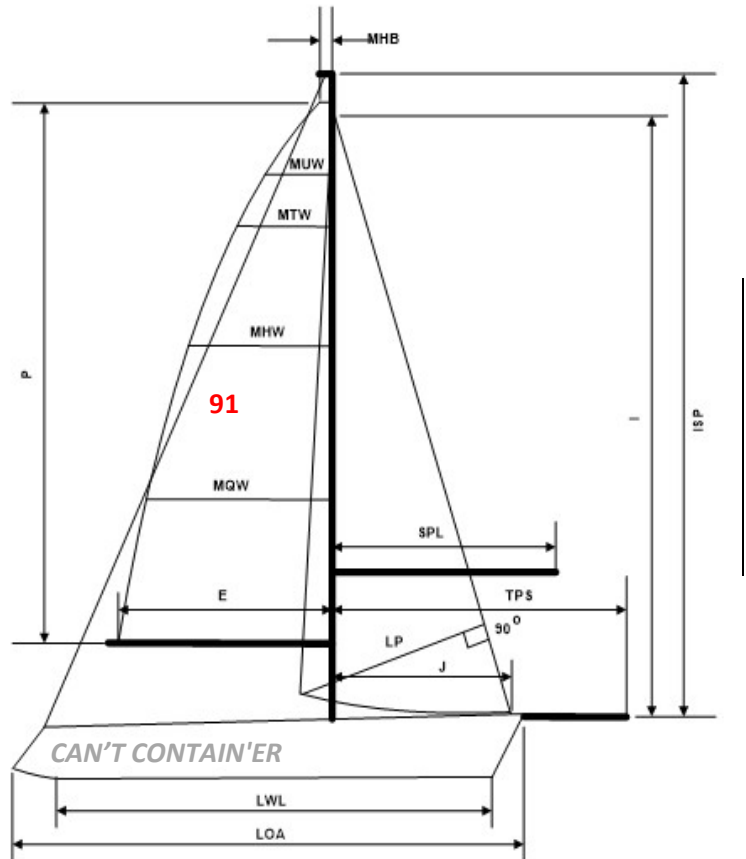

HANDICAP ADJUSTMENTS

+6ASM / +9 3BX

Adjustments must be requested by the owner and are only made based on visual inspection and/or physical measurement by an authorized PHRF-SS measurer.

Owner Signature: _____

My signature attests to the fact that all the information contained on this certificate is true and correct to the best of my knowledge and that I have not made any modifications to the boat which have not been reported to PHRF-SS.

Certificate Issue: 4/28/2026

Certificate Expires: 3/31/2027



SOUTH SHORE PHRF HANDICAP CERTIFICATE 2026

PHRF-SS, LLC., PO Box 347021, Cleveland, OH 44134

<http://phrfss.org>

HCP (Spinnaker): 96 sec/nm
NSP (Non-Spinnaker): 106 sec/nm
PPF (Perf Prediction Factor): 5.35
TCF (Time Correction Factor): 1.0472
CRWT (Crew Weight Limit): 1901 LBS.

YACHT NAME: TULA-TULA
DESIGN: FIRST 30 (BENET) SPRIT
OWNER: Mark Corson
CERTIFICATE: PRLM
CLASSIFICATION: DISP
SAIL NO: 61939
POWER: IB
YACHT CLUB: EWYC

LOA: 31 FT.
LWL: 29 FT.
BEAM: 10 FT.
DRAFT: 6.71 FT.
DISPLACEMENT: 6702 LBS.
BALLAST: 2359 LBS.
SAIL AREA: 525 SQ. FT.
THS: 7.18 KN.

I: 37.30 FT.
ISP: 44.16 FT.
J: 14.21 FT.
JSP/TPS: 17.36 FT.
P: 39.21 FT.
E: 13.26 FT.

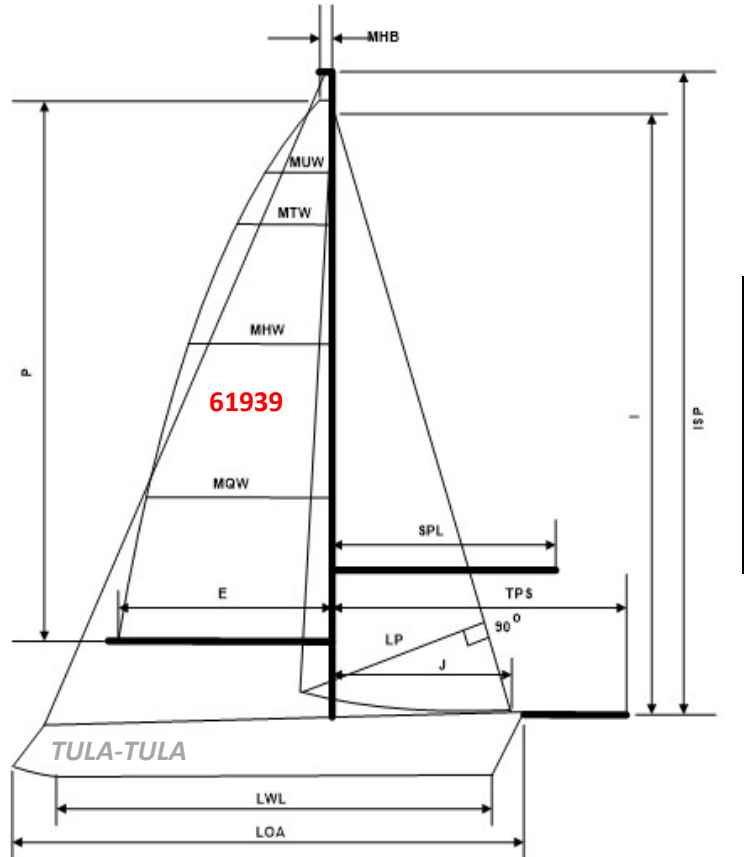

HANDICAP ADJUSTMENTS

Adjustments must be requested by the owner and are only made based on visual inspection and/or physical measurement by an authorized PHRF-SS measurer.

Owner Signature: _____

My signature attests to the fact that all the information contained on this certificate is true and correct to the best of my knowledge and that I have not made any modifications to the boat which have not been reported to PHRF-SS.

Certificate Issue: 3/1/2026

Certificate Expires: 3/31/2027



SOUTH SHORE PHRF HANDICAP CERTIFICATE 2026

PHRF-SS, LLC., PO Box 347021, Cleveland, OH 44134

<http://phrfss.org>

HCP (Spinnaker): 168 sec/nm
NSP (Non-Spinnaker): 176 sec/nm
PPF (Perf Prediction Factor): 14.73
TCF (Time Correction Factor): 0.9407
CRWT (Crew Weight Limit): 1852 LBS.

YACHT NAME: SNIPPERDOG
DESIGN: CAT 320 WK
OWNER: Phillip Dubiel
CERTIFICATE: **STND**
CLASSIFICATION: DISP
SAIL NO: 365
POWER: IB
YACHT CLUB: EWYC

LOA: 33 FT.
LWL: 28 FT.
BEAM: 12 FT.
DRAFT: 4.30 FT.
DISPLACEMENT: 11700 LBS.
BALLAST: 4400 LBS.
SAIL AREA: 520 SQ. FT.
THS: 7.09 KN.

I: 43.58 FT.
ISP: 43.58 FT.
J: 12.33 FT.
JSP/TPS: 12.33 FT.
P: 38.00 FT.
E: 13.25 FT.

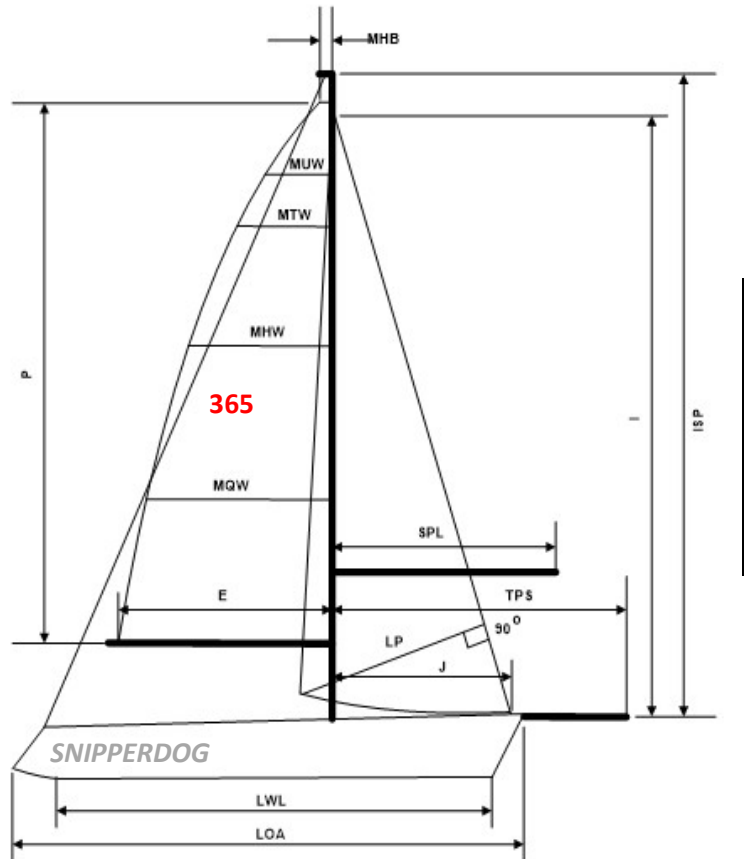

HANDICAP ADJUSTMENTS

+3 RFG

Adjustments must be requested by the owner and are only made based on visual inspection and/or physical measurement by an authorized PHRF-SS measurer.

Owner Signature: _____

My signature attests to the fact that all the information contained on this certificate is true and correct to the best of my knowledge and that I have not made any modifications to the boat which have not been reported to PHRF-SS.

Certificate Issue: 3/22/2026

Certificate Expires: 3/31/2027



SOUTH SHORE PHRF HANDICAP CERTIFICATE 2026

PHRF-SS, LLC., PO Box 347021, Cleveland, OH 44134

<http://phrfss.org>

HCP (Spinnaker): 177 sec/nm
NSP (Non-Spinnaker): 187 sec/nm
PPF (Perf Prediction Factor): 18.98
TCF (Time Correction Factor): 0.9289
CRWT (Crew Weight Limit): 1722 LBS.

YACHT NAME: GOBLIN
DESIGN: CAT 30 TRBS
OWNER: Andrew Dupuis
CERTIFICATE: **STND**
CLASSIFICATION: DISP
SAIL NO: 4118
POWER: IB
YACHT CLUB: EWYC

LOA: 30 FT.
LWL: 25 FT.
BEAM: 11 FT.
DRAFT: 5.25 FT.
DISPLACEMENT: 10200 LBS.
BALLAST: 4250 LBS.
SAIL AREA: 451 SQ. FT.
THS: 6.70 KN.

I: 41.00 FT.
ISP: 41.00 FT.
J: 11.50 FT.
JSP/TPS: 13.15 FT.
P: 37.50 FT.
E: 11.50 FT.

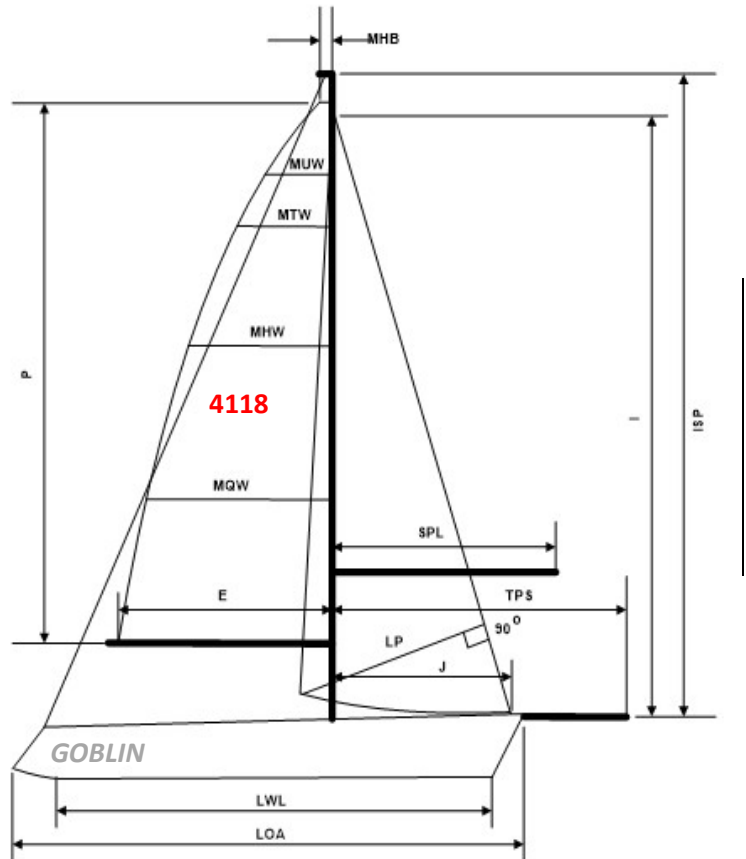

HANDICAP ADJUSTMENTS

+3RFG

Adjustments must be requested by the owner and are only made based on visual inspection and/or physical measurement by an authorized PHRF-SS measurer.

Owner Signature: _____

My signature attests to the fact that all the information contained on this certificate is true and correct to the best of my knowledge and that I have not made any modifications to the boat which have not been reported to PHRF-SS.

Certificate Issue: 5/27/2026

Certificate Expires: 3/31/2027



SOUTH SHORE PHRF HANDICAP CERTIFICATE 2026

PHRF-SS, LLC., PO Box 347021, Cleveland, OH 44134

<http://phrfss.org>

HCP (Spinnaker): 90 sec/nm
NSP (Non-Spinnaker): 100 sec/nm
PPF (Perf Prediction Factor): 6.77
TCF (Time Correction Factor): 1.0571
CRWT (Crew Weight Limit): 2061 LBS.

YACHT NAME: OVATION
DESIGN: J-105 ODR
OWNER: Tom & Cindy Einhouse
CERTIFICATE: **STND**
CLASSIFICATION: DISP
SAIL NO: 393
POWER: IB
YACHT CLUB: EWYC

LOA: 35 FT.
LWL: 30 FT.
BEAM: 11 FT.
DRAFT: 6.50 FT.
DISPLACEMENT: 8575 LBS.
BALLAST: 3400 LBS.
SAIL AREA: 577 SQ. FT.
THS: 7.28 KN.

I: 40.60 FT.
ISP: 42.10 FT.
J: 13.50 FT.
JSP/TPS: 19.00 FT.
P: 41.50 FT.
E: 14.60 FT.

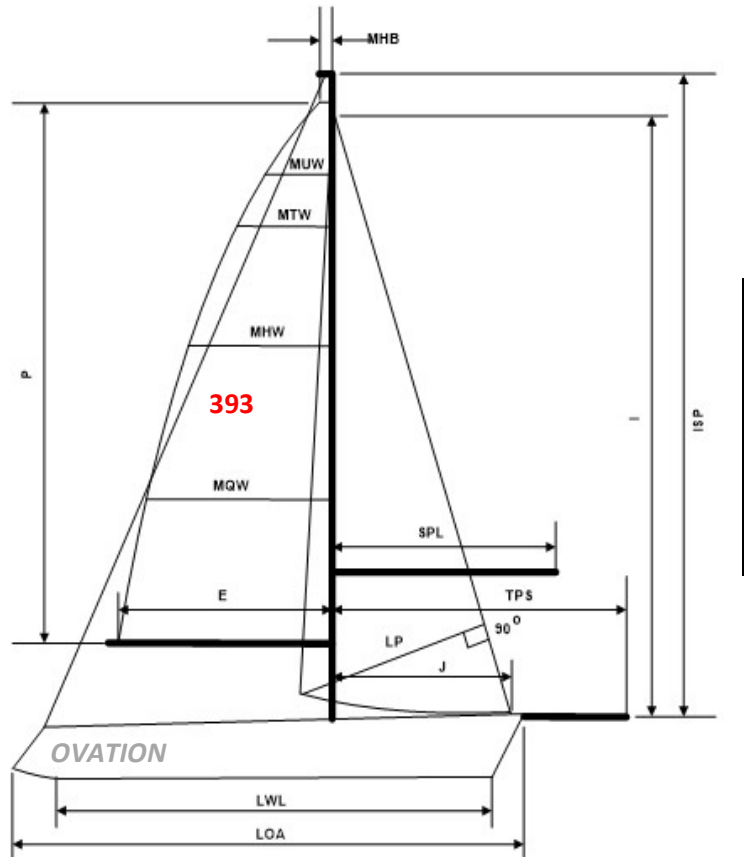

HANDICAP ADJUSTMENTS

ODR 102% JIB/89 SQM ASYM

Adjustments must be requested by the owner and are only made based on visual inspection and/or physical measurement by an authorized PHRF-SS measurer.

Owner Signature: _____

My signature attests to the fact that all the information contained on this certificate is true and correct to the best of my knowledge and that I have not made any modifications to the boat which have not been reported to PHRF-SS.

Certificate Issue: 3/1/2026

Certificate Expires: 3/31/2027



SOUTH SHORE PHRF HANDICAP CERTIFICATE 2026

PHRF-SS, LLC., PO Box 347021, Cleveland, OH 44134

<http://phrfss.org>

HCP (Spinnaker): 177 sec/nm
NSP (Non-Spinnaker): 182 sec/nm
PPF (Perf Prediction Factor): 10.64
TCF (Time Correction Factor): 0.9289
CRWT (Crew Weight Limit): 1541 LBS.

YACHT NAME: UPSTART
DESIGN: S2 7.9 DB IB
OWNER: Jack Filak
CERTIFICATE: STND
CLASSIFICATION: DISP
SAIL NO: 2521
POWER: IB
YACHT CLUB: EWYC

LOA: 26 FT.
LWL: 22 FT.
BEAM: 9 FT.
DRAFT: 5.00 FT.
DISPLACEMENT: 4577 LBS.
BALLAST: 1550 LBS.
SAIL AREA: 325 SQ. FT.
THS: 6.24 KN.

I: 30.50 FT.
ISP: 30.50 FT.
J: 9.50 FT.
JSP/TPS: 9.50 FT.
P: 29.42 FT.
E: 12.25 FT.

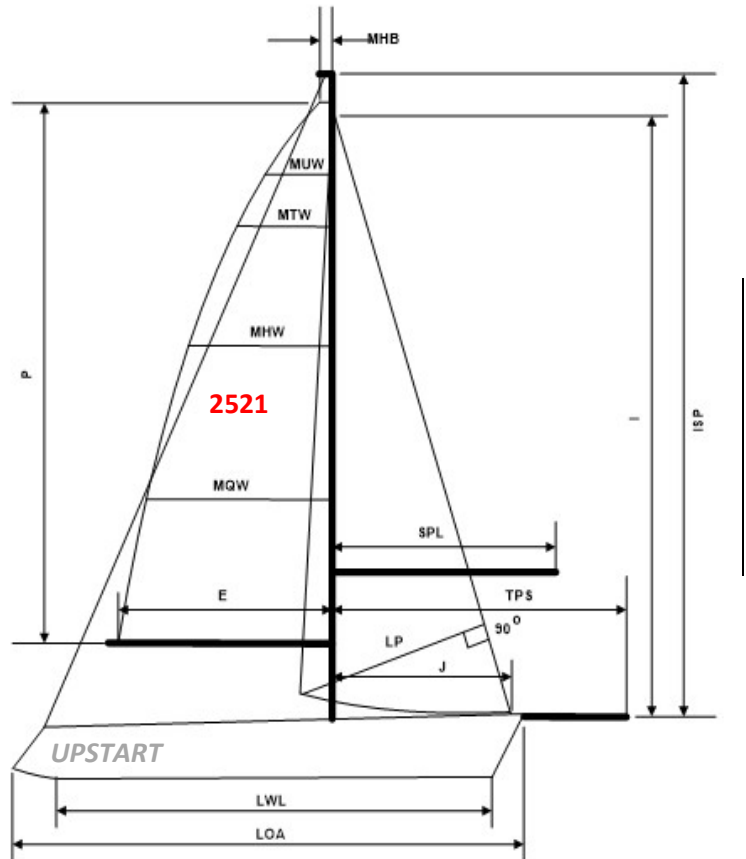

HANDICAP ADJUSTMENTS

Adjustments must be requested by the owner and are only made based on visual inspection and/or physical measurement by an authorized PHRF-SS measurer.

Owner Signature: _____

My signature attests to the fact that all the information contained on this certificate is true and correct to the best of my knowledge and that I have not made any modifications to the boat which have not been reported to PHRF-SS.

Certificate Issue: 3/5/2026

Certificate Expires: 3/31/2027



SOUTH SHORE PHRF HANDICAP CERTIFICATE 2026

PHRF-SS, LLC., PO Box 347021, Cleveland, OH 44134

<http://phrfss.org>

HCP (Spinnaker): 66 sec/nm
NSP (Non-Spinnaker): 75 sec/nm
PPF (Perf Prediction Factor): 6.08
TCF (Time Correction Factor): 1.0990
CRWT (Crew Weight Limit): 2289 LBS.

YACHT NAME: BREEZIN'
DESIGN: C&C 115 SPRIT
OWNER: Rich Galaska
CERTIFICATE: **STND**
CLASSIFICATION: DISP
SAIL NO: 11555
POWER: IB
YACHT CLUB: FCYC

LOA: 38 FT.
LWL: 33 FT.
BEAM: 12 FT.
DRAFT: 6.67 FT.
DISPLACEMENT: 11800 LBS.
BALLAST: 4200 LBS.
SAIL AREA: 781 SQ. FT.
THS: 7.70 KN.

I: 52.16 FT.
ISP: 52.16 FT.
J: 14.50 FT.
JSP/TPS: 19.00 FT.
P: 49.33 FT.
E: 16.33 FT.

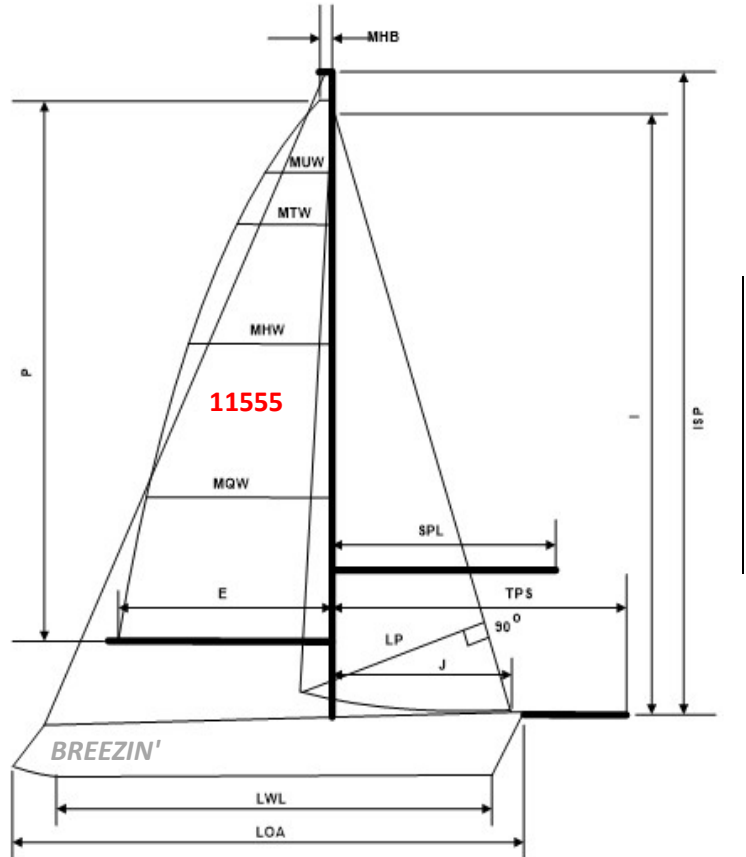

HANDICAP ADJUSTMENTS

Adjustments must be requested by the owner and are only made based on visual inspection and/or physical measurement by an authorized PHRF-SS measurer.

Owner Signature: _____

My signature attests to the fact that all the information contained on this certificate is true and correct to the best of my knowledge and that I have not made any modifications to the boat which have not been reported to PHRF-SS.

Certificate Issue: 4/4/2026

Certificate Expires: 3/31/2027



SOUTH SHORE PHRF HANDICAP CERTIFICATE 2026

PHRF-SS, LLC., PO Box 347021, Cleveland, OH 44134

<http://phrfss.org>

HCP (Spinnaker): 171 sec/nm
NSP (Non-Spinnaker): 180 sec/nm
PPF (Perf Prediction Factor): 14.17
TCF (Time Correction Factor): 0.9367
CRWT (Crew Weight Limit): 1840 LBS.

YACHT NAME: VERKTADUE
DESIGN: IRWIN 32 CITATION SHLW
OWNER: Jeff Geisinger
CERTIFICATE: **STND**
CLASSIFICATION: DISP
SAIL NO: 321
POWER: IB
YACHT CLUB: EWYC

LOA: 32 FT.
LWL: 27 FT.
BEAM: 11 FT.
DRAFT: 4.00 FT.
DISPLACEMENT: 10500 LBS.
BALLAST: 4600 LBS.
SAIL AREA: 518 SQ. FT.
THS: 6.93 KN.

I: 43.00 FT.
ISP: 43.00 FT.
J: 13.20 FT.
JSP/TPS: 13.20 FT.
P: 37.50 FT.
E: 12.50 FT.

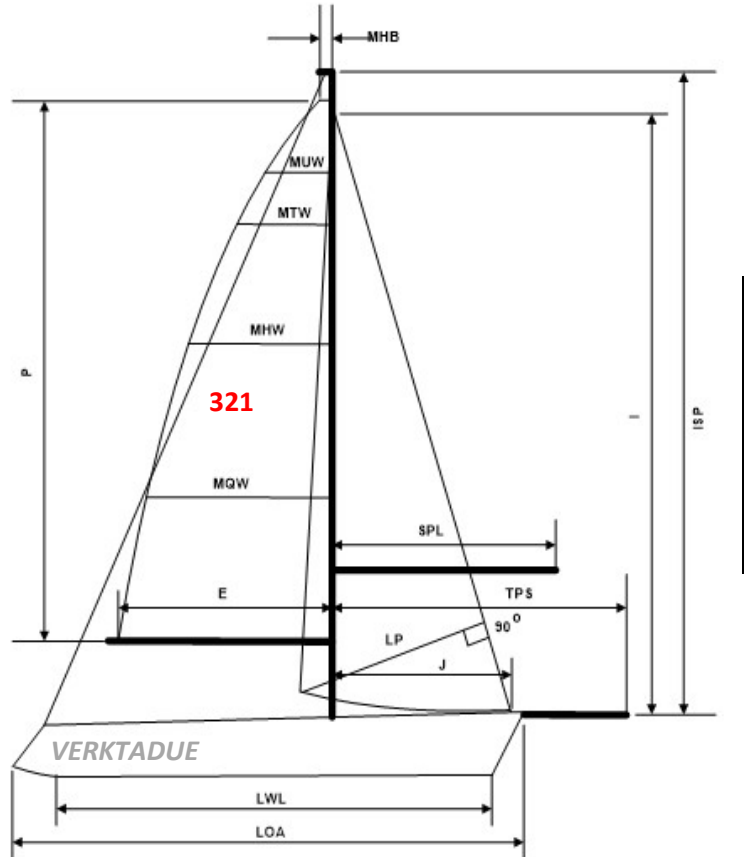

HANDICAP ADJUSTMENTS

+3 RFG

Adjustments must be requested by the owner and are only made based on visual inspection and/or physical measurement by an authorized PHRF-SS measurer.

Owner Signature: _____

My signature attests to the fact that all the information contained on this certificate is true and correct to the best of my knowledge and that I have not made any modifications to the boat which have not been reported to PHRF-SS.

Certificate Issue: 2/26/2026

Certificate Expires: 3/31/2027



SOUTH SHORE PHRF HANDICAP CERTIFICATE 2026

PHRF-SS, LLC., PO Box 347021, Cleveland, OH 44134

<http://phrfss.org>

HCP (Spinnaker): 153 sec/nm
NSP (Non-Spinnaker): 157 sec/nm
PPF (Perf Prediction Factor): 11.59
TCF (Time Correction Factor): 0.9610
CRWT (Crew Weight Limit): 1989 LBS.

YACHT NAME: TIGGER
DESIGN: FIRST (BENET) 32s5 WK
OWNER: Paul Harrison
CERTIFICATE: **STND**
CLASSIFICATION: DISP
SAIL NO: 72
POWER: IB
YACHT CLUB: FCYC

LOA: 35 FT.
LWL: 29 FT.
BEAM: 12 FT.
DRAFT: 6.00 FT.
DISPLACEMENT: 11460 LBS.
BALLAST: 4190 LBS.
SAIL AREA: 554 SQ. FT.
THS: 7.26 KN.

I: 41.66 FT.
ISP: 41.66 FT.
J: 11.15 FT.
JSP/TPS: 11.15 FT.
P: 42.65 FT.
E: 15.09 FT.

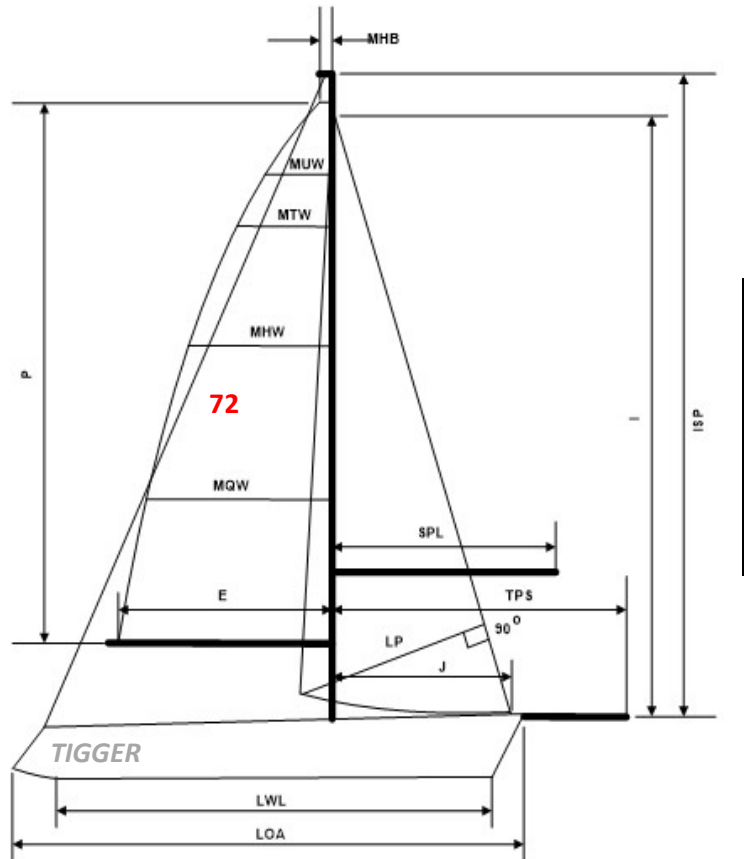

HANDICAP ADJUSTMENTS

+3 RFG

Adjustments must be requested by the owner and are only made based on visual inspection and/or physical measurement by an authorized PHRF-SS measurer.

Owner Signature: _____

My signature attests to the fact that all the information contained on this certificate is true and correct to the best of my knowledge and that I have not made any modifications to the boat which have not been reported to PHRF-SS.

Certificate Issue: 3/23/2026

Certificate Expires: 3/31/2027



SOUTH SHORE PHRF HANDICAP CERTIFICATE 2026

PHRF-SS, LLC., PO Box 347021, Cleveland, OH 44134

<http://phrfss.org>

HCP (Spinnaker): 48 sec/nm
NSP (Non-Spinnaker): 56 sec/nm
PPF (Perf Prediction Factor): 7.22
TCF (Time Correction Factor): 1.1327
CRWT (Crew Weight Limit): 2380 LBS.

YACHT NAME: CommoHAWK
DESIGN: J-39
OWNER: Conor Hawkins
CERTIFICATE: **STND**
CLASSIFICATION: DISP
SAIL NO: 43511
POWER: IB
YACHT CLUB: EWYC

LOA: 39.42 FT.
LWL: 32.50 FT.
BEAM: 12.42 FT.
DRAFT: 7.25 FT.
DISPLACEMENT: 12900 LBS.
BALLAST: 5900 LBS.
SAIL AREA: 799 SQ. FT.
THS: 7.64 KN.

I: 53.50 FT.
ISP: 53.50 FT.
J: 15.50 FT.
JSP/TPS: 15.50 FT.
P: 47.20 FT.
E: 16.30 FT.

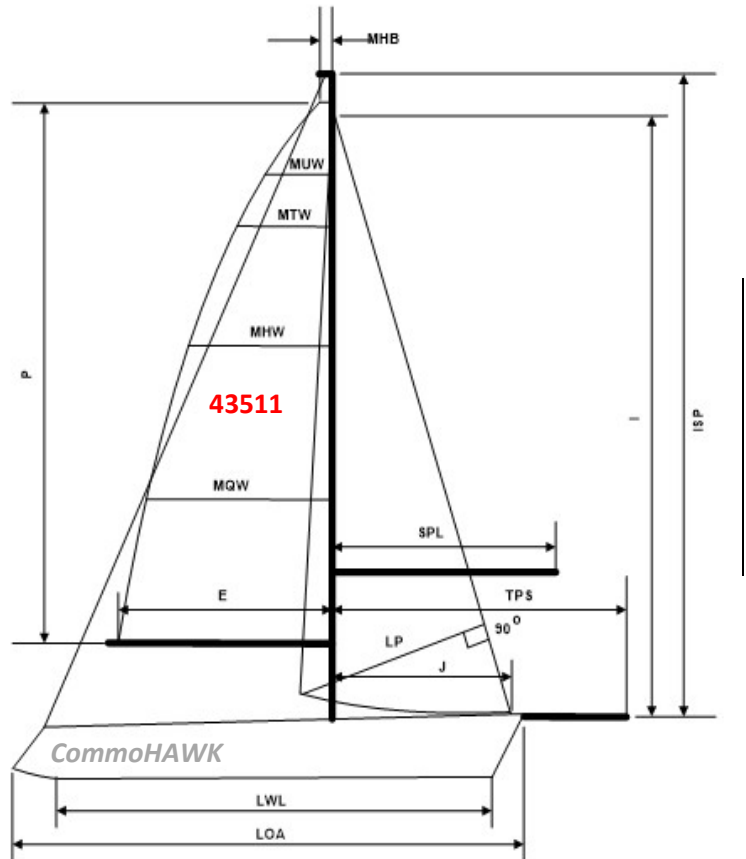

HANDICAP ADJUSTMENTS

Adjustments must be requested by the owner and are only made based on visual inspection and/or physical measurement by an authorized PHRF-SS measurer.

Owner Signature: _____

My signature attests to the fact that all the information contained on this certificate is true and correct to the best of my knowledge and that I have not made any modifications to the boat which have not been reported to PHRF-SS.

Certificate Issue: 3/5/2026

Certificate Expires: 3/31/2027



SOUTH SHORE PHRF HANDICAP CERTIFICATE 2026

PHRF-SS, LLC., PO Box 347021, Cleveland, OH 44134

<http://phrfss.org>

HCP (Spinnaker): 75 sec/nm
NSP (Non-Spinnaker): 83 sec/nm
PPF (Perf Prediction Factor): 9.10
TCF (Time Correction Factor): 1.0829
CRWT (Crew Weight Limit): 2133 LBS.

YACHT NAME: GLASS PONY
DESIGN: FIRST (BENET) 35-2
OWNER: Jason Huffman
CERTIFICATE: **STND**
CLASSIFICATION: DISP
SAIL NO: 25649
POWER: IB
YACHT CLUB: SSC

LOA: 35 FT.
LWL: 31 FT.
BEAM: 12 FT.
DRAFT: 7.19 FT.
DISPLACEMENT: 11909 LBS.
BALLAST: 3682 LBS.
SAIL AREA: 664 SQ. FT.
THS: 7.41 KN.

I: 46.82 FT.
ISP: 52.14 FT.
J: 12.93 FT.
JSP/TPS: 15.93 FT.
P: 45.87 FT.
E: 15.75 FT.

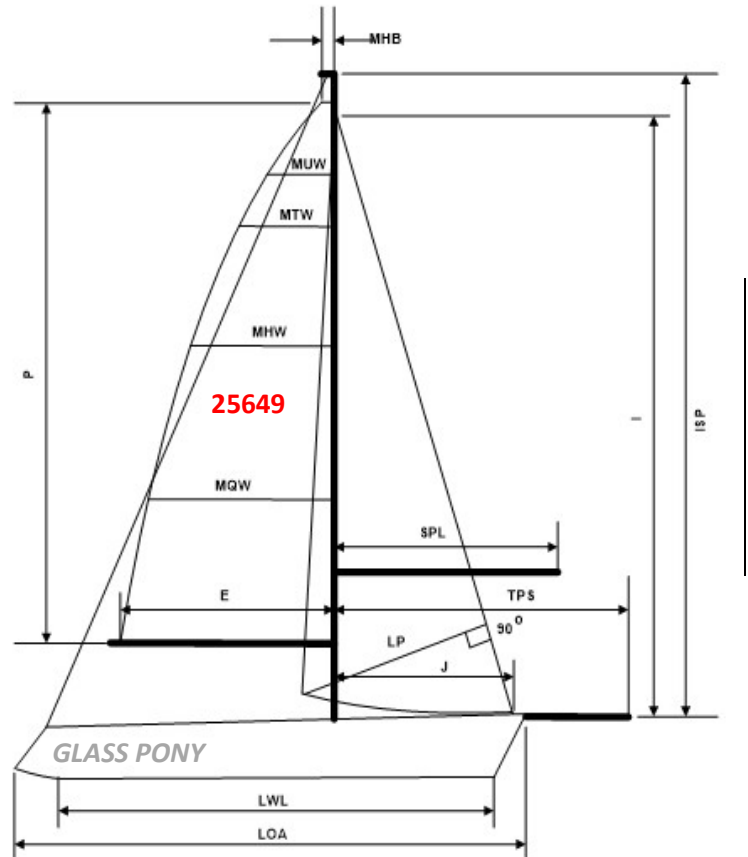

HANDICAP ADJUSTMENTS

Using sym and asym; 3ft sprit added

Adjustments must be requested by the owner and are only made based on visual inspection and/or physical measurement by an authorized PHRF-SS measurer.

Owner Signature: _____

My signature attests to the fact that all the information contained on this certificate is true and correct to the best of my knowledge and that I have not made any modifications to the boat which have not been reported to PHRF-SS.

Certificate Issue: 3/5/2026

Certificate Expires: 3/31/2027



SOUTH SHORE PHRF HANDICAP CERTIFICATE 2026

PHRF-SS, LLC., PO Box 347021, Cleveland, OH 44134

<http://phrfss.org>

HCP (Spinnaker): 90 sec/nm
NSP (Non-Spinnaker): 100 sec/nm
PPF (Perf Prediction Factor): 6.77
TCF (Time Correction Factor): 1.0571
CRWT (Crew Weight Limit): 2061 LBS.

YACHT NAME: LEGACY
DESIGN: J-105 ODR
OWNER: Brad Kahn
CERTIFICATE: **STND**
CLASSIFICATION: DISP
SAIL NO: 602
POWER: IB
YACHT CLUB: FCYC

LOA: 35 FT.
LWL: 30 FT.
BEAM: 11 FT.
DRAFT: 6.50 FT.
DISPLACEMENT: 8575 LBS.
BALLAST: 3400 LBS.
SAIL AREA: 577 SQ. FT.
THS: 7.28 KN.

I: 40.60 FT.
ISP: 42.10 FT.
J: 13.50 FT.
JSP/TPS: 19.00 FT.
P: 41.50 FT.
E: 14.60 FT.

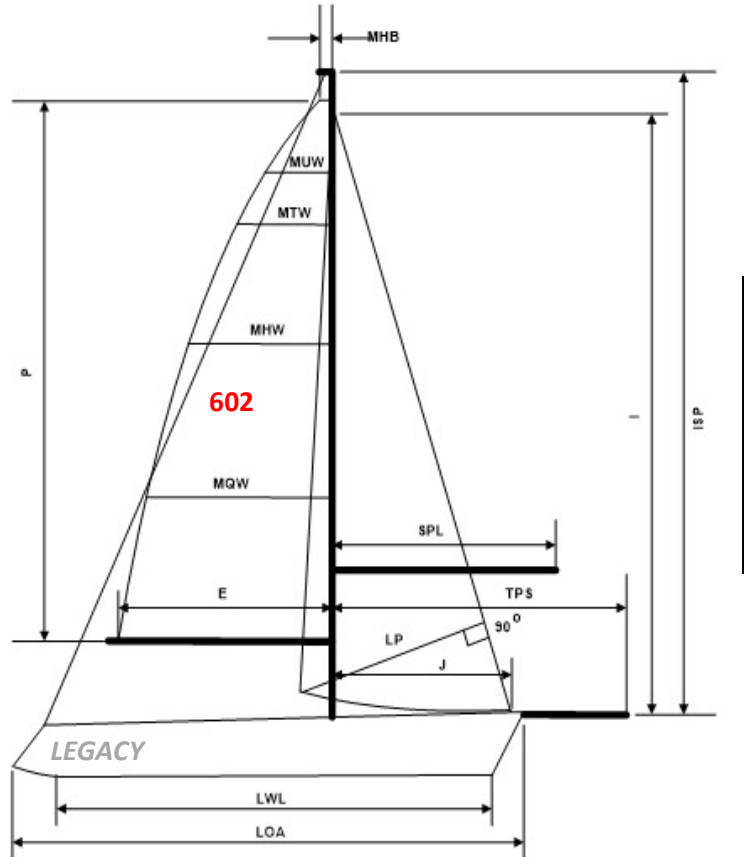

HANDICAP ADJUSTMENTS

ODR 102% JIB/89 SQM ASYM

Adjustments must be requested by the owner and are only made based on visual inspection and/or physical measurement by an authorized PHRF-SS measurer.

Owner Signature: _____

My signature attests to the fact that all the information contained on this certificate is true and correct to the best of my knowledge and that I have not made any modifications to the boat which have not been reported to PHRF-SS.

Certificate Issue: 6/17/2026

Certificate Expires: 3/31/2027



SOUTH SHORE PHRF HANDICAP CERTIFICATE 2026

PHRF-SS, LLC., PO Box 347021, Cleveland, OH 44134

<http://phrfss.org>

HCP (Spinnaker): 180 sec/nm
NSP (Non-Spinnaker): 188 sec/nm
PPF (Perf Prediction Factor): 14.73
TCF (Time Correction Factor): 0.9250
CRWT (Crew Weight Limit): 1832 LBS.

YACHT NAME: AD ASTRA
DESIGN: CAT 320 WK
OWNER: David Kriska/Duffy
CERTIFICATE: **STND**
CLASSIFICATION: DISP
SAIL NO: 207
POWER: IB
YACHT CLUB: E55M

LOA: 32.50 FT.
LWL: 28.00 FT.
BEAM: 11.75 FT.
DRAFT: 4.30 FT.
DISPLACEMENT: 11700 LBS.
BALLAST: 4400 LBS.
SAIL AREA: 520 SQ. FT.
THS: 7.09 KN.

I: 43.58 FT.
ISP: 43.58 FT.
J: 12.33 FT.
JSP/TPS: 12.33 FT.
P: 38.00 FT.
E: 13.25 FT.

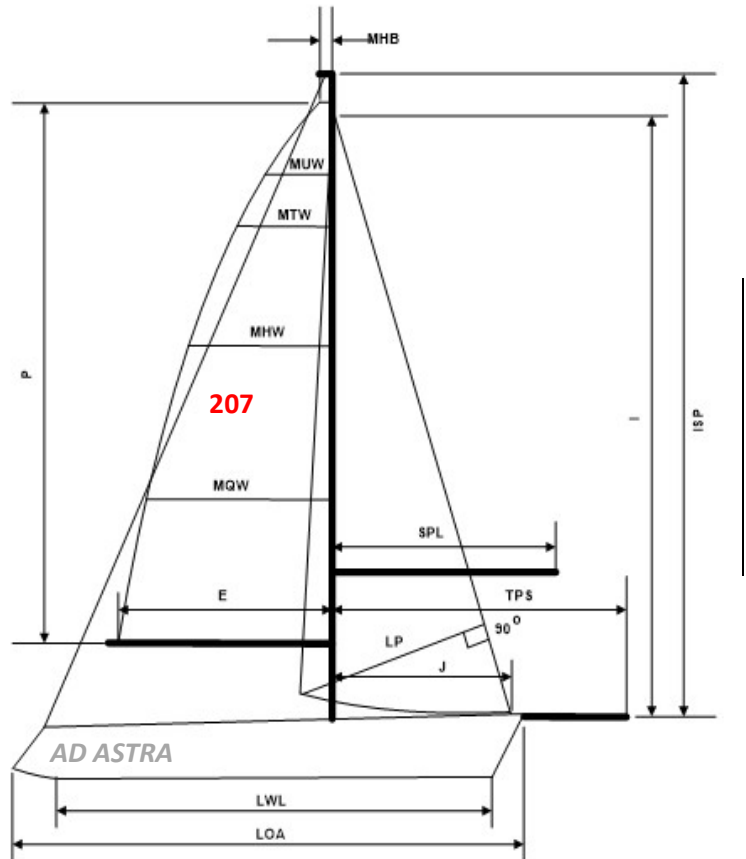

HANDICAP ADJUSTMENTS

+9(3BX) / +6RFG

Adjustments must be requested by the owner and are only made based on visual inspection and/or physical measurement by an authorized PHRF-SS measurer.

Owner Signature: _____

My signature attests to the fact that all the information contained on this certificate is true and correct to the best of my knowledge and that I have not made any modifications to the boat which have not been reported to PHRF-SS.

Certificate Issue: 6/15/2026

Certificate Expires: 3/31/2027



SOUTH SHORE PHRF HANDICAP CERTIFICATE 2026

PHRF-SS, LLC., PO Box 347021, Cleveland, OH 44134

<http://phrfss.org>

HCP (Spinnaker): -15 sec/nm
NSP (Non-Spinnaker): -9 sec/nm
PPF (Perf Prediction Factor): 3.63
TCF (Time Correction Factor): 1.2686
CRWT (Crew Weight Limit): 2564 LBS.

YACHT NAME: EXODUS
DESIGN: FARR 40 OD MH
OWNER: Frank Kups
CERTIFICATE: **STND**
CLASSIFICATION: HPRF
SAIL NO: 40036
POWER: IB
YACHT CLUB: LYC

LOA: 41 FT.
LWL: 35 FT.
BEAM: 13 FT.
DRAFT: 8.53 FT.
DISPLACEMENT: 10902 LBS.
BALLAST: 4960 LBS.
SAIL AREA: 940 SQ. FT.
THS: 7.96 KN.

I: 53.15 FT.
ISP: 60.70 FT.
J: 15.44 FT.
JSP/TPS: 17.06 FT.
P: 54.78 FT.
E: 19.35 FT.

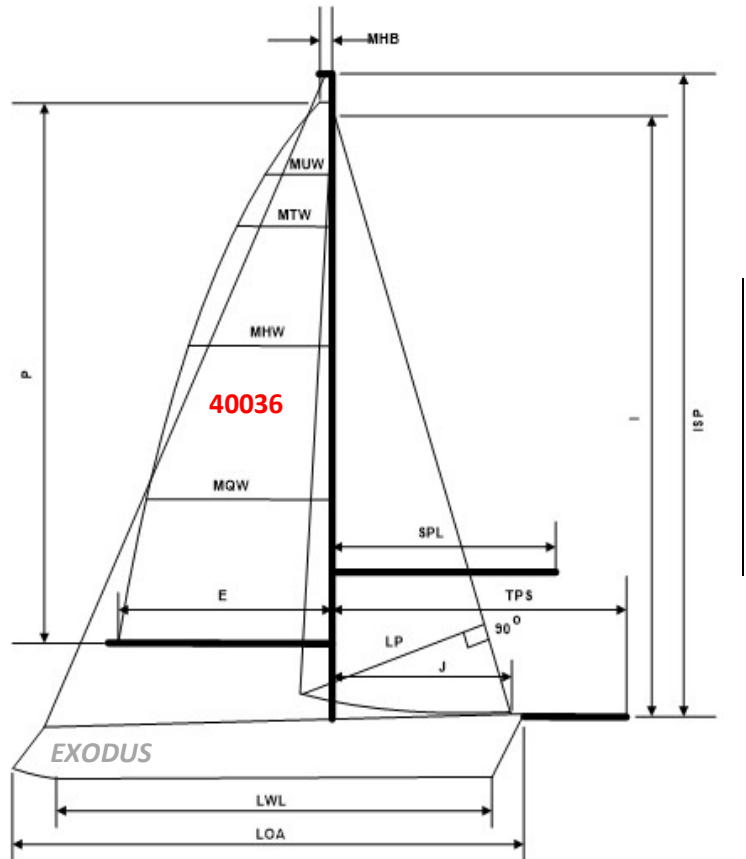

HANDICAP ADJUSTMENTS

-3 SQTm / -3ASYM

Adjustments must be requested by the owner and are only made based on visual inspection and/or physical measurement by an authorized PHRF-SS measurer.

Owner Signature: _____

My signature attests to the fact that all the information contained on this certificate is true and correct to the best of my knowledge and that I have not made any modifications to the boat which have not been reported to PHRF-SS.

Certificate Issue: 6/17/2026

Certificate Expires: 3/31/2027



SOUTH SHORE PHRF HANDICAP CERTIFICATE 2026

PHRF-SS, LLC., PO Box 347021, Cleveland, OH 44134

<http://phrfss.org>

HCP (Spinnaker): 84 sec/nm
NSP (Non-Spinnaker): 95 sec/nm
PPF (Perf Prediction Factor): 4.79
TCF (Time Correction Factor): 1.0673
CRWT (Crew Weight Limit): 1835 LBS.

YACHT NAME: BANTAM
DESIGN: J-88 ODR
OWNER: Brian Lake
CERTIFICATE: **STND**
CLASSIFICATION: DISP
SAIL NO: 30
POWER: IB
YACHT CLUB: MHYC

LOA: 29.19 FT.
LWL: 26.84 FT.
BEAM: 9.50 FT.
DRAFT: 6.50 FT.
DISPLACEMENT: 4990 LBS.
BALLAST: 1840 LBS.
SAIL AREA: 439 SQ. FT.
THS: 6.94 KN.

I: 38.67 FT.
ISP: 41.80 FT.
J: 11.28 FT.
JSP/TPS: 18.05 FT.
P: 36.82 FT.
E: 12.00 FT.

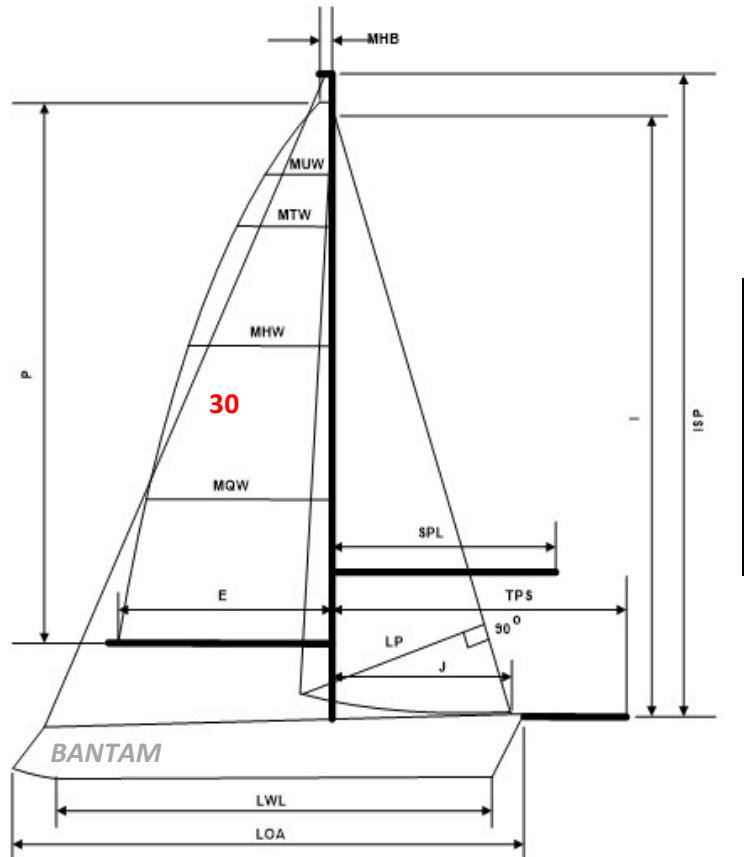

HANDICAP ADJUSTMENTS

Adjustments must be requested by the owner and are only made based on visual inspection and/or physical measurement by an authorized PHRF-SS measurer.

Owner Signature: _____

My signature attests to the fact that all the information contained on this certificate is true and correct to the best of my knowledge and that I have not made any modifications to the boat which have not been reported to PHRF-SS.

Certificate Issue: 4/15/2026

Certificate Expires: 3/31/2027



SOUTH SHORE PHRF HANDICAP CERTIFICATE 2026

PHRF-SS, LLC., PO Box 347021, Cleveland, OH 44134

<http://phrfss.org>

HCP (Spinnaker): 228 sec/nm
NSP (Non-Spinnaker): 235 sec/nm
PPF (Perf Prediction Factor): 7.51
TCF (Time Correction Factor): 0.8672
CRWT (Crew Weight Limit): 1335 LBS.

YACHT NAME: SISU
DESIGN: SANTANA 2023 A TM
OWNER: Jeff Lehtinen
CERTIFICATE: **STND**
CLASSIFICATION: DISP
SAIL NO: 2023
POWER: IB
YACHT CLUB: GRSC

LOA: 23 FT.
LWL: 21 FT.
BEAM: 9 FT.
DRAFT: 5.33 FT.
DISPLACEMENT: 2880 LBS.
BALLAST: 1300 LBS.
SAIL AREA: 247 SQ. FT.
THS: 6.08 KN.

I: 25.41 FT.
ISP: 30.00 FT.
J: 8.75 FT.
JSP/TPS: 8.75 FT.
P: 27.17 FT.
E: 10.00 FT.

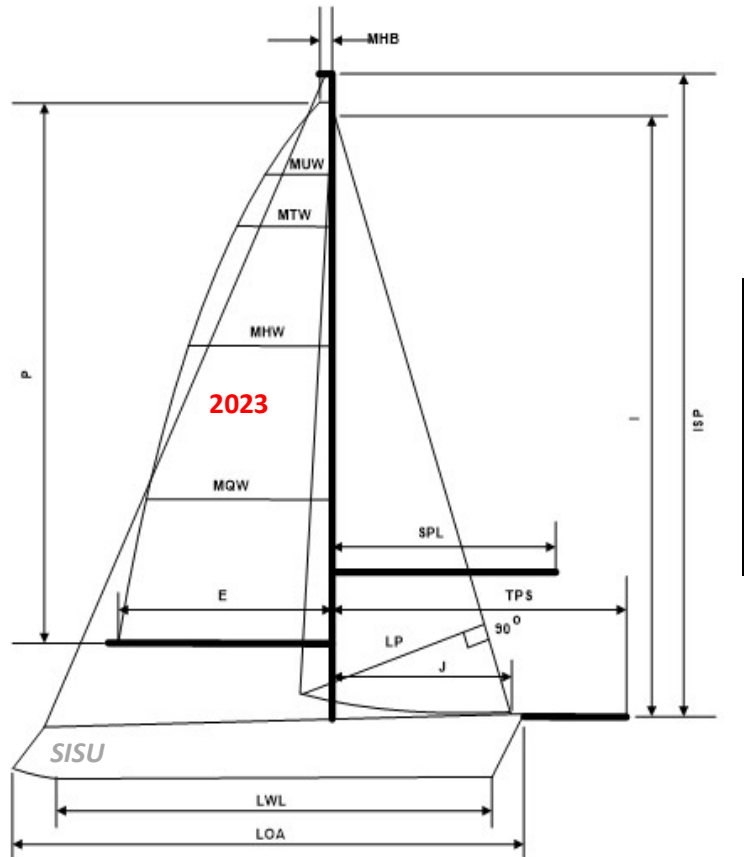

HANDICAP ADJUSTMENTS

Water ballast must be kept on-board

Adjustments must be requested by the owner and are only made based on visual inspection and/or physical measurement by an authorized PHRF-SS measurer.

Owner Signature: _____

My signature attests to the fact that all the information contained on this certificate is true and correct to the best of my knowledge and that I have not made any modifications to the boat which have not been reported to PHRF-SS.

Certificate Issue: 4/6/2026

Certificate Expires: 3/31/2027



SOUTH SHORE PHRF HANDICAP CERTIFICATE 2026

PHRF-SS, LLC., PO Box 347021, Cleveland, OH 44134

<http://phrfss.org>

HCP (Spinnaker): 69 sec/nm
NSP (Non-Spinnaker): 79 sec/nm
PPF (Perf Prediction Factor): 6.29
TCF (Time Correction Factor): 1.0936
CRWT (Crew Weight Limit): 2172 LBS.

YACHT NAME: WAVELENGTH
DESIGN: THOMAS 35
OWNER: Al Linne
CERTIFICATE: **STND**
CLASSIFICATION: DISP
SAIL NO: 60812
POWER: IB
YACHT CLUB: EWYC

LOA: 35 FT.
LWL: 31 FT.
BEAM: 12 FT.
DRAFT: 6.83 FT.
DISPLACEMENT: 9800 LBS.
BALLAST: 4450 LBS.
SAIL AREA: 702 SQ. FT.
THS: 7.40 KN.

I: 48.00 FT.
ISP: 48.00 FT.
J: 14.25 FT.
JSP/TPS: 18.75 FT.
P: 48.00 FT.
E: 15.00 FT.

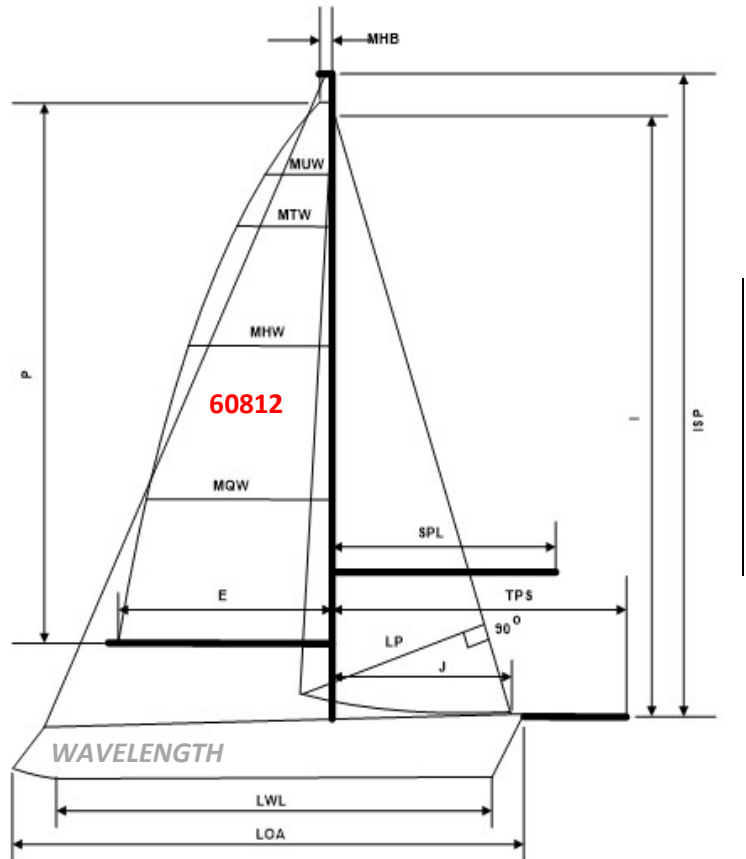

HANDICAP ADJUSTMENTS

-3CM / 129% A-2 ASYM FRAC

Adjustments must be requested by the owner and are only made based on visual inspection and/or physical measurement by an authorized PHRF-SS measurer.

Owner Signature: _____

My signature attests to the fact that all the information contained on this certificate is true and correct to the best of my knowledge and that I have not made any modifications to the boat which have not been reported to PHRF-SS.

Certificate Issue: 3/1/2026

Certificate Expires: 3/31/2027



SOUTH SHORE PHRF HANDICAP CERTIFICATE 2026

PHRF-SS, LLC., PO Box 347021, Cleveland, OH 44134

<http://phrfss.org>

HCP (Spinnaker): 172 sec/nm
NSP (Non-Spinnaker): 180 sec/nm
PPF (Perf Prediction Factor): 14.73
TCF (Time Correction Factor): 0.9354
CRWT (Crew Weight Limit): 1845 LBS.

YACHT NAME: LONGSHOT
DESIGN: CAT 320 WK
OWNER: David Long
CERTIFICATE: STND
CLASSIFICATION: DISP
SAIL NO: 44
POWER: IB
YACHT CLUB: FCYC

LOA: 32.50 FT.
LWL: 28.00 FT.
BEAM: 11.75 FT.
DRAFT: 4.30 FT.
DISPLACEMENT: 11700 LBS.
BALLAST: 4400 LBS.
SAIL AREA: 520 SQ. FT.
THS: 7.09 KN.

I: 43.58 FT.
ISP: 43.58 FT.
J: 12.33 FT.
JSP/TPS: 12.33 FT.
P: 38.00 FT.
E: 13.25 FT.

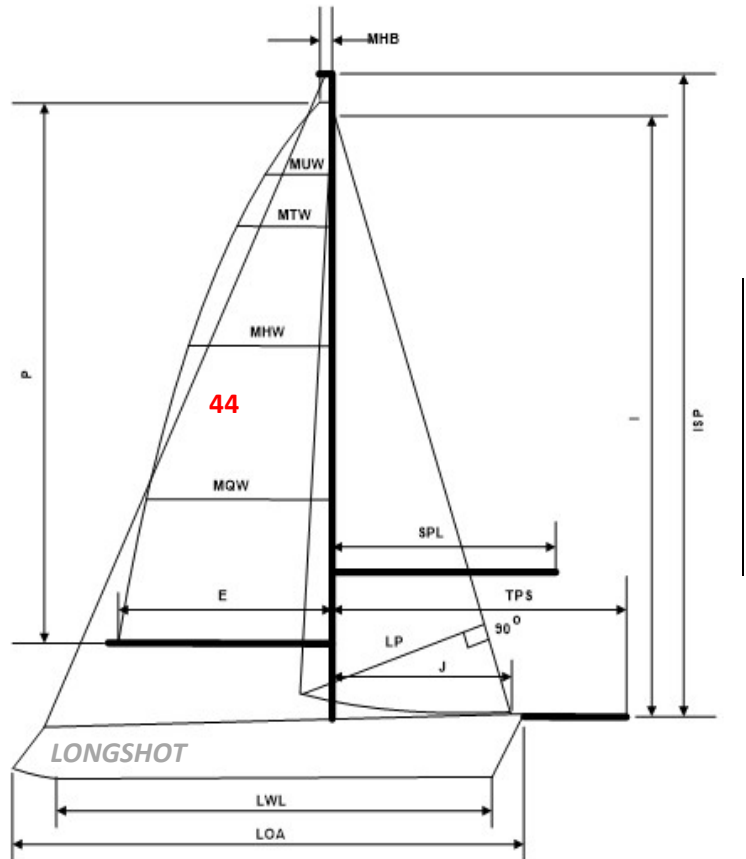

HANDICAP ADJUSTMENTS

+3(2BX); +6RFG

Adjustments must be requested by the owner and are only made based on visual inspection and/or physical measurement by an authorized PHRF-SS measurer.

Owner Signature: _____

My signature attests to the fact that all the information contained on this certificate is true and correct to the best of my knowledge and that I have not made any modifications to the boat which have not been reported to PHRF-SS.

Certificate Issue: 5/11/2026

Certificate Expires: 3/31/2027



SOUTH SHORE PHRF HANDICAP CERTIFICATE 2026

PHRF-SS, LLC., PO Box 347021, Cleveland, OH 44134

<http://phrfss.org>

HCP (Spinnaker): 105 sec/nm
NSP (Non-Spinnaker): 115 sec/nm
PPF (Perf Prediction Factor): 10.74
TCF (Time Correction Factor): 1.0326
CRWT (Crew Weight Limit): 1907 LBS.

YACHT NAME: MOKO JUMBIE
DESIGN: J-97e
OWNER: Jim Mackey
CERTIFICATE: **STND**
CLASSIFICATION: DISP
SAIL NO: 74
POWER: IB
YACHT CLUB: EWYC

LOA: 32 FT.
LWL: 27 FT.
BEAM: 11 FT.
DRAFT: 6.30 FT.
DISPLACEMENT: 8600 LBS.
BALLAST: 2900 LBS.
SAIL AREA: 498 SQ. FT.
THS: 6.91 KN.

I: 41.25 FT.
ISP: 45.00 FT.
J: 11.71 FT.
JSP/TPS: 16.64 FT.
P: 39.50 FT.
E: 13.00 FT.

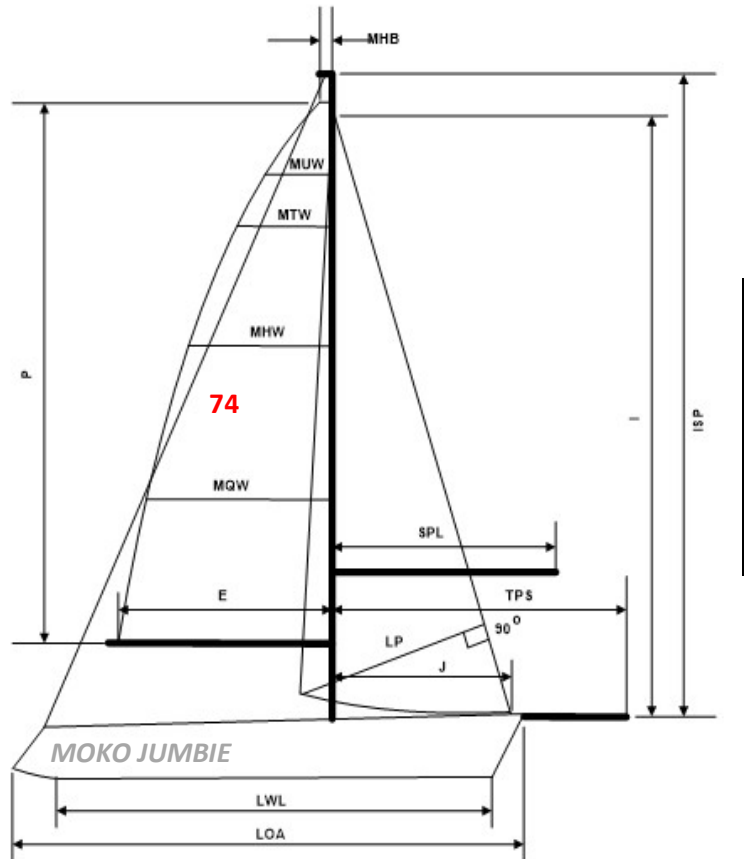

HANDICAP ADJUSTMENTS

+3 RFG/J1/J3/J4/A1.5/A3(declared)

Adjustments must be requested by the owner and are only made based on visual inspection and/or physical measurement by an authorized PHRF-SS measurer.

Owner Signature: _____

My signature attests to the fact that all the information contained on this certificate is true and correct to the best of my knowledge and that I have not made any modifications to the boat which have not been reported to PHRF-SS.

Certificate Issue: 5/13/2026

Certificate Expires: 3/31/2027



SOUTH SHORE PHRF HANDICAP CERTIFICATE 2026

PHRF-SS, LLC., PO Box 347021, Cleveland, OH 44134

<http://phrfss.org>

HCP (Spinnaker): 150 sec/nm
NSP (Non-Spinnaker): 160 sec/nm
PPF (Perf Prediction Factor): 11.86
TCF (Time Correction Factor): 0.9652
CRWT (Crew Weight Limit): 1962 LBS.

YACHT NAME: INTERLUDE
DESIGN: CAT 34 MKI TM
OWNER: Tim McBride
CERTIFICATE: **STND**
CLASSIFICATION: DISP
SAIL NO: 167
POWER: IB
YACHT CLUB: ELYC

LOA: 34.50 FT.
LWL: 29.83 FT.
BEAM: 11.75 FT.
DRAFT: 5.58 FT.
DISPLACEMENT: 11950 LBS.
BALLAST: 5000 LBS.
SAIL AREA: 554 SQ. FT.
THS: 7.32 KN.

I: 46.00 FT.
ISP: 46.00 FT.
J: 13.50 FT.
JSP/TPS: 13.50 FT.
P: 40.50 FT.
E: 12.00 FT.

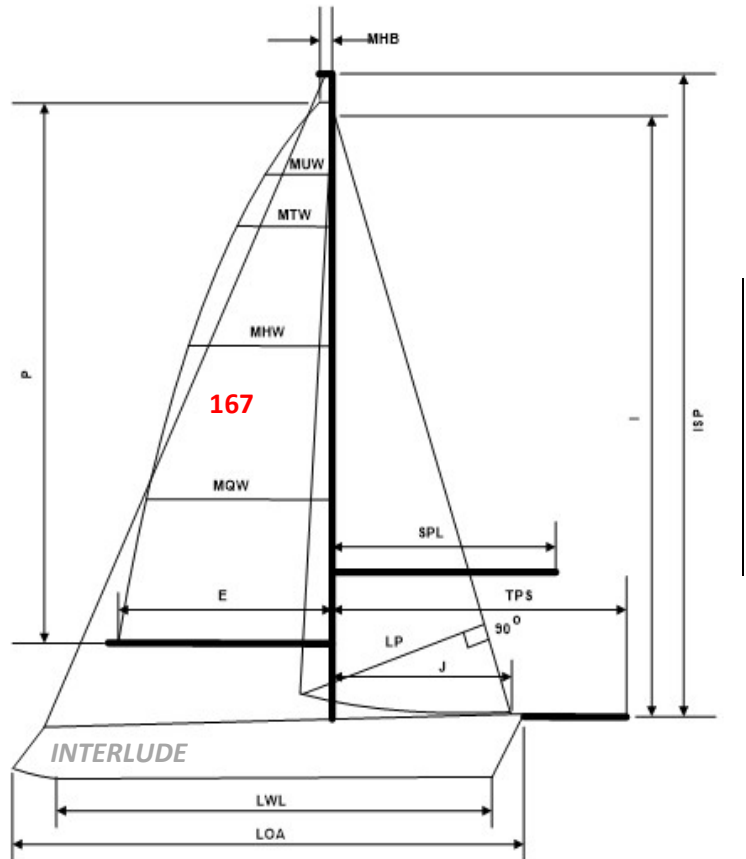

HANDICAP ADJUSTMENTS

+3RFG / 2BX to 3BX +3

Adjustments must be requested by the owner and are only made based on visual inspection and/or physical measurement by an authorized PHRF-SS measurer.

Owner Signature: _____

My signature attests to the fact that all the information contained on this certificate is true and correct to the best of my knowledge and that I have not made any modifications to the boat which have not been reported to PHRF-SS.

Certificate Issue: 6/4/2026

Certificate Expires: 3/31/2027



SOUTH SHORE PHRF HANDICAP CERTIFICATE 2026

PHRF-SS, LLC., PO Box 347021, Cleveland, OH 44134

<http://phrfss.org>

HCP (Spinnaker): 75 sec/nm
NSP (Non-Spinnaker): 84 sec/nm
PPF (Perf Prediction Factor): 5.51
TCF (Time Correction Factor): 1.0829
CRWT (Crew Weight Limit): 2051 LBS.

YACHT NAME: OVERKILL
DESIGN: TARTAN 101
OWNER: Tom McNeill
CERTIFICATE: **STND**
CLASSIFICATION: DISP
SAIL NO: 10101
POWER: IB
YACHT CLUB: CYC

LOA: 33.00 FT.
LWL: 29.75 FT.
BEAM: 10.95 FT.
DRAFT: 6.50 FT.
DISPLACEMENT: 8100 LBS.
BALLAST: 3350 LBS.
SAIL AREA: 628 SQ. FT.
THS: 7.31 KN.

I: 46.57 FT.
ISP: 50.34 FT.
J: 12.57 FT.
JSP/TPS: 16.80 FT.
P: 45.11 FT.
E: 14.86 FT.

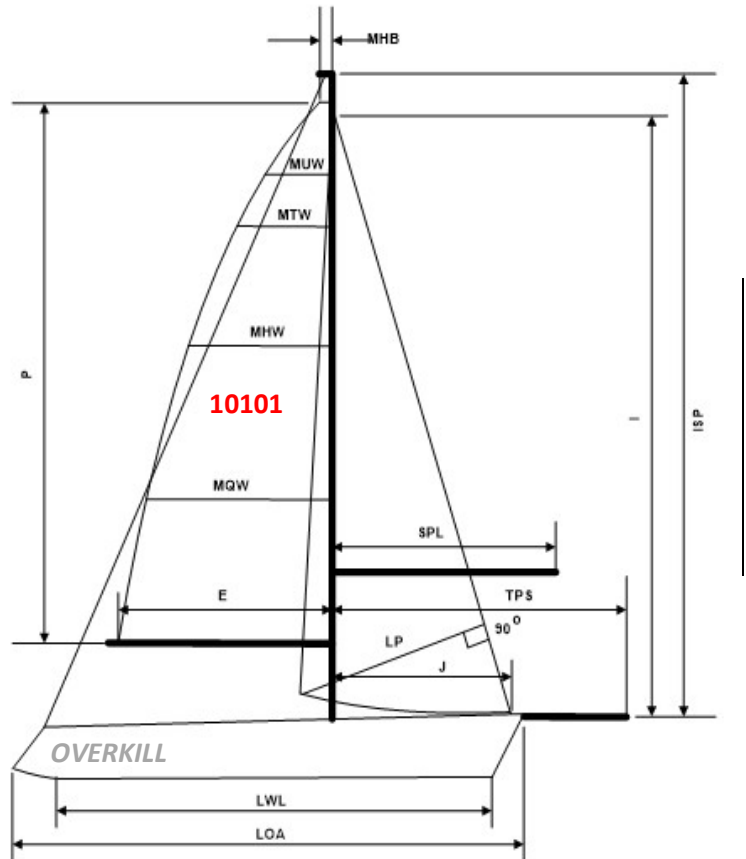

HANDICAP ADJUSTMENTS

Adjustments must be requested by the owner and are only made based on visual inspection and/or physical measurement by an authorized PHRF-SS measurer.

Owner Signature: _____

My signature attests to the fact that all the information contained on this certificate is true and correct to the best of my knowledge and that I have not made any modifications to the boat which have not been reported to PHRF-SS.

Certificate Issue: 6/17/2026

Certificate Expires: 3/31/2027



SOUTH SHORE PHRF HANDICAP CERTIFICATE 2026

PHRF-SS, LLC., PO Box 347021, Cleveland, OH 44134

<http://phrfss.org>

HCP (Spinnaker): 15 sec/nm
NSP (Non-Spinnaker): 24 sec/nm
PPF (Perf Prediction Factor): 1.99
TCF (Time Correction Factor): 1.2000
CRWT (Crew Weight Limit): 2062 LBS.

YACHT NAME: FLAT STANLEY RACING
DESIGN: MELGES 32 ODR
OWNER: Terry McSweeney
CERTIFICATE: **STND**
CLASSIFICATION: HPRF
SAIL NO: 1215
POWER: IB
YACHT CLUB: EWYC

LOA: 32 FT.
LWL: 29 FT.
BEAM: 10 FT.
DRAFT: 7.00 FT.
DISPLACEMENT: 3774 LBS.
BALLAST: 1570 LBS.
SAIL AREA: 554 SQ. FT.
THS: 7.15 KN.

I: 39.90 FT.
ISP: 48.20 FT.
J: 10.80 FT.
JSP/TPS: 19.43 FT.
P: 44.00 FT.
E: 15.40 FT.

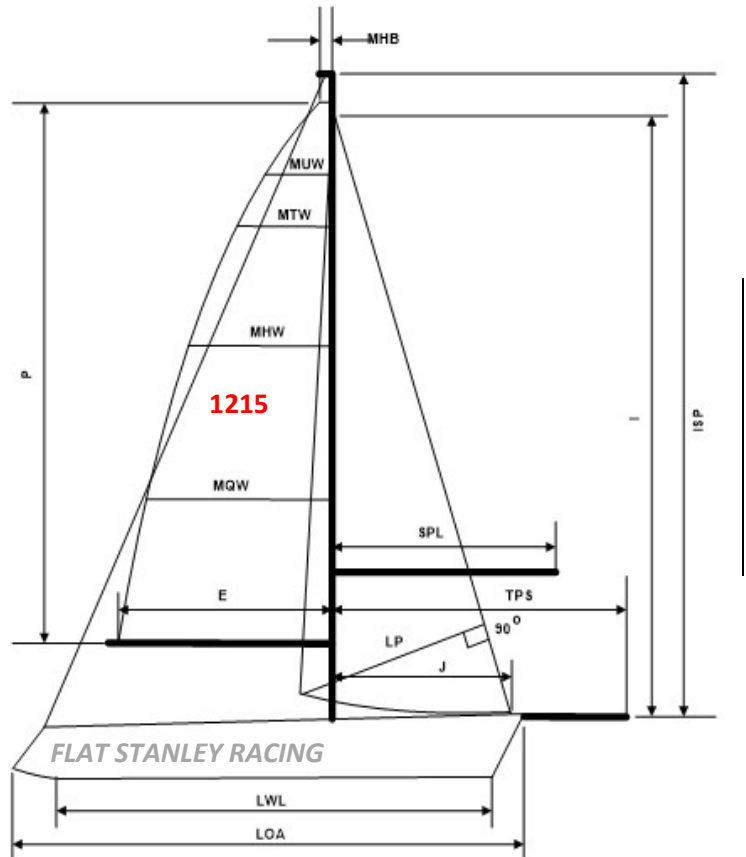

HANDICAP ADJUSTMENTS

Adjustments must be requested by the owner and are only made based on visual inspection and/or physical measurement by an authorized PHRF-SS measurer.

Owner Signature: _____

My signature attests to the fact that all the information contained on this certificate is true and correct to the best of my knowledge and that I have not made any modifications to the boat which have not been reported to PHRF-SS.

Certificate Issue: 6/15/2026

Certificate Expires: 3/31/2027



SOUTH SHORE PHRF HANDICAP CERTIFICATE 2026

PHRF-SS, LLC., PO Box 347021, Cleveland, OH 44134

<http://phrfss.org>

HCP (Spinnaker): 153 sec/nm
NSP (Non-Spinnaker): 161 sec/nm
PPF (Perf Prediction Factor): 13.32
TCF (Time Correction Factor): 0.9610
CRWT (Crew Weight Limit): 1988 LBS.

YACHT NAME: RUM FRONT
DESIGN: BENET 343 SD
OWNER: Mills/Read
CERTIFICATE: **STND**
CLASSIFICATION: DISP
SAIL NO: 25670
POWER: IB
YACHT CLUB: EWYC

LOA: 35.50 FT.
LWL: 30.83 FT.
BEAM: 11.42 FT.
DRAFT: 6.23 FT.
DISPLACEMENT: 13448 LBS.
BALLAST: 3402 LBS.
SAIL AREA: 544 SQ. FT.
THS: 7.44 KN.

I: 43.44 FT.
ISP: 43.44 FT.
J: 12.80 FT.
JSP/TPS: 12.80 FT.
P: 39.14 FT.
E: 13.58 FT.

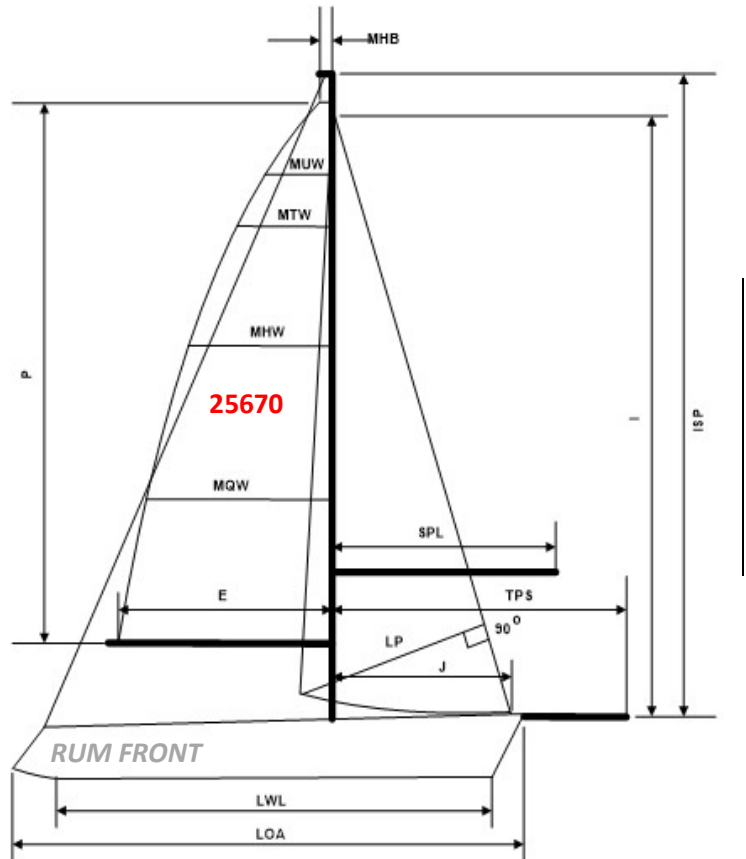

HANDICAP ADJUSTMENTS

+3 RFM

Adjustments must be requested by the owner and are only made based on visual inspection and/or physical measurement by an authorized PHRF-SS measurer.

Owner Signature: _____

My signature attests to the fact that all the information contained on this certificate is true and correct to the best of my knowledge and that I have not made any modifications to the boat which have not been reported to PHRF-SS.

Certificate Issue: 5/31/2026

Certificate Expires: 3/31/2027



SOUTH SHORE PHRF HANDICAP CERTIFICATE 2026

PHRF-SS, LLC., PO Box 347021, Cleveland, OH 44134

<http://phrfss.org>

HCP (Spinnaker): 90 sec/nm
NSP (Non-Spinnaker): 100 sec/nm
PPF (Perf Prediction Factor): 6.77
TCF (Time Correction Factor): 1.0571
CRWT (Crew Weight Limit): 2061 LBS.

YACHT NAME: UNBRIDLED
DESIGN: J-105 ODR
OWNER: Rob Mock
CERTIFICATE: **STND**
CLASSIFICATION: DISP
SAIL NO: 261
POWER: IB
YACHT CLUB: EWYC

LOA: 35 FT.
LWL: 30 FT.
BEAM: 11 FT.
DRAFT: 6.50 FT.
DISPLACEMENT: 8575 LBS.
BALLAST: 3400 LBS.
SAIL AREA: 577 SQ. FT.
THS: 7.28 KN.

I: 40.60 FT.
ISP: 42.10 FT.
J: 13.50 FT.
JSP/TPS: 19.00 FT.
P: 41.50 FT.
E: 14.60 FT.

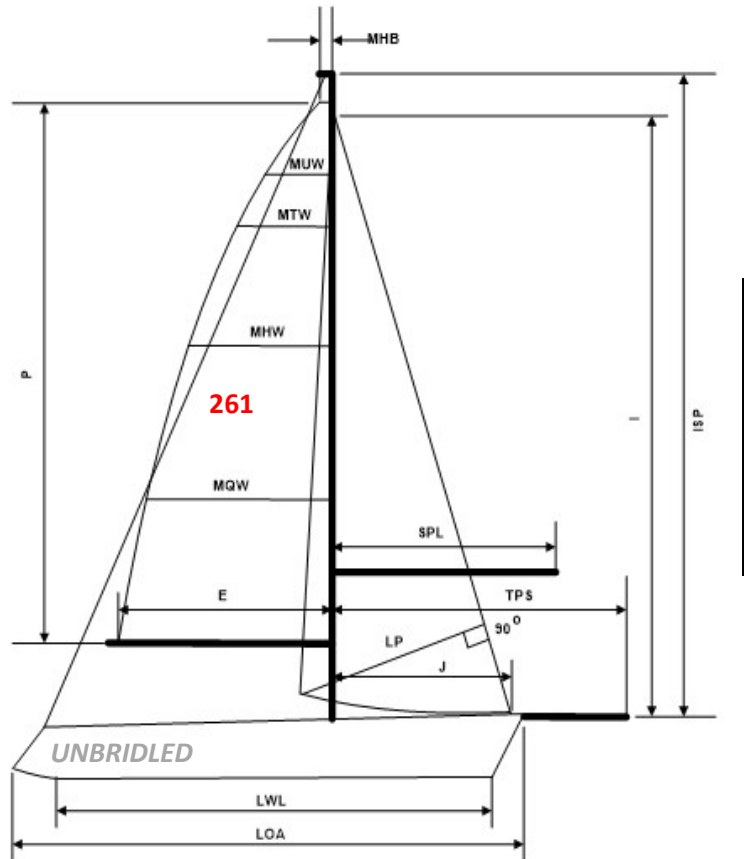

HANDICAP ADJUSTMENTS

ODR 102% JIB/89 SQM ASYM

Adjustments must be requested by the owner and are only made based on visual inspection and/or physical measurement by an authorized PHRF-SS measurer.

Owner Signature: _____

My signature attests to the fact that all the information contained on this certificate is true and correct to the best of my knowledge and that I have not made any modifications to the boat which have not been reported to PHRF-SS.

Certificate Issue: 3/5/2026

Certificate Expires: 3/31/2027



SOUTH SHORE PHRF HANDICAP CERTIFICATE 2026

PHRF-SS, LLC., PO Box 347021, Cleveland, OH 44134

<http://phrfss.org>

HCP (Spinnaker): 117 sec/nm
NSP (Non-Spinnaker): 127 sec/nm
PPF (Perf Prediction Factor): 7.86
TCF (Time Correction Factor):
CRWT (Crew Weight Limit): 1802 LBS.

YACHT NAME: AQUARIUS
DESIGN: J-29 MH IB
OWNER: Matthew Newberry
CERTIFICATE: STND
CLASSIFICATION: DISP
SAIL NO: 41229
POWER: IB
YACHT CLUB: EWYC

LOA: 30 FT.
LWL: 25 FT.
BEAM: 11 FT.
DRAFT: 5.60 FT.
DISPLACEMENT: 6000 LBS.
BALLAST: 2100 LBS.
SAIL AREA: 450 SQ. FT.
THS: 6.70 KN.

I: 40.00 FT.
ISP: 40.00 FT.
J: 12.00 FT.
JSP/TPS: 14.75 FT.
P: 35.00 FT.
E: 12.00 FT.

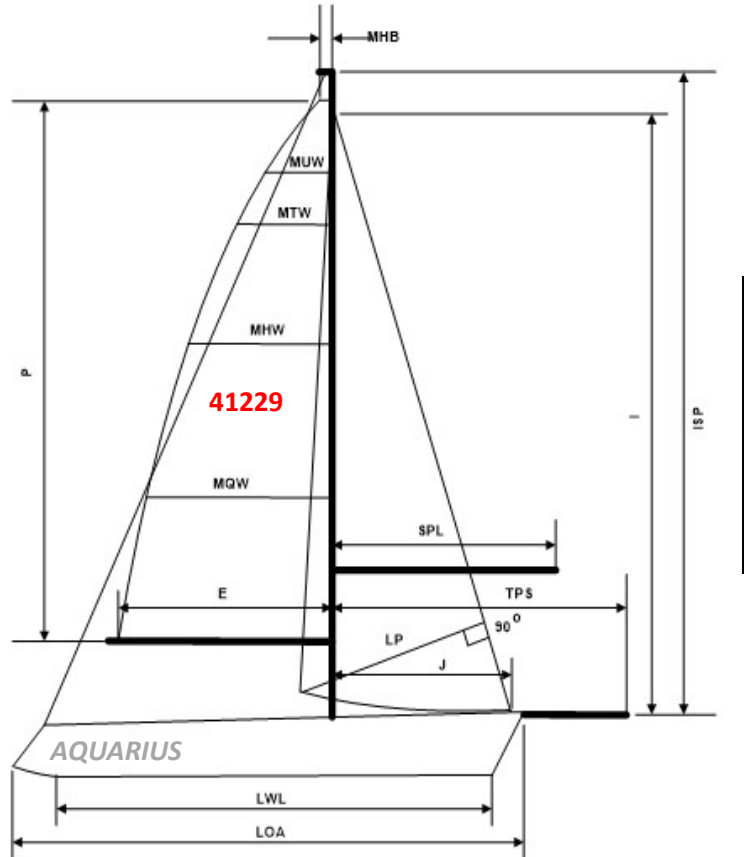

HANDICAP ADJUSTMENTS

124% Asym Declared

Adjustments must be requested by the owner and are only made based on visual inspection and/or physical measurement by an authorized PHRF-SS measurer.

Owner Signature: _____

My signature attests to the fact that all the information contained on this certificate is true and correct to the best of my knowledge and that I have not made any modifications to the boat which have not been reported to PHRF-SS.

Certificate Issue: 3/22/2026

Certificate Expires: 3/31/2027



SOUTH SHORE PHRF HANDICAP CERTIFICATE 2026

PHRF-SS, LLC., PO Box 347021, Cleveland, OH 44134

<http://phrfss.org>

HCP (Spinnaker): 135 sec/nm
NSP (Non-Spinnaker): 141 sec/nm
PPF (Perf Prediction Factor): 10.57
TCF (Time Correction Factor): 0.9867
CRWT (Crew Weight Limit): 1914 LBS.

YACHT NAME: EN PASSANT
DESIGN: DEHLER 34
OWNER: Jeffrey Posner
CERTIFICATE: **STND**
CLASSIFICATION: DISP
SAIL NO: 85
POWER: IB
YACHT CLUB: ELYC

LOA: 33 FT.
LWL: 27 FT.
BEAM: 11 FT.
DRAFT: 5.74 FT.
DISPLACEMENT: 8818 LBS.
BALLAST: 3968 LBS.
SAIL AREA: 492 SQ. FT.
THS: 6.99 KN.

I: 38.71 FT.
ISP: 38.71 FT.
J: 11.97 FT.
JSP/TPS: 11.97 FT.
P: 38.71 FT.
E: 13.45 FT.

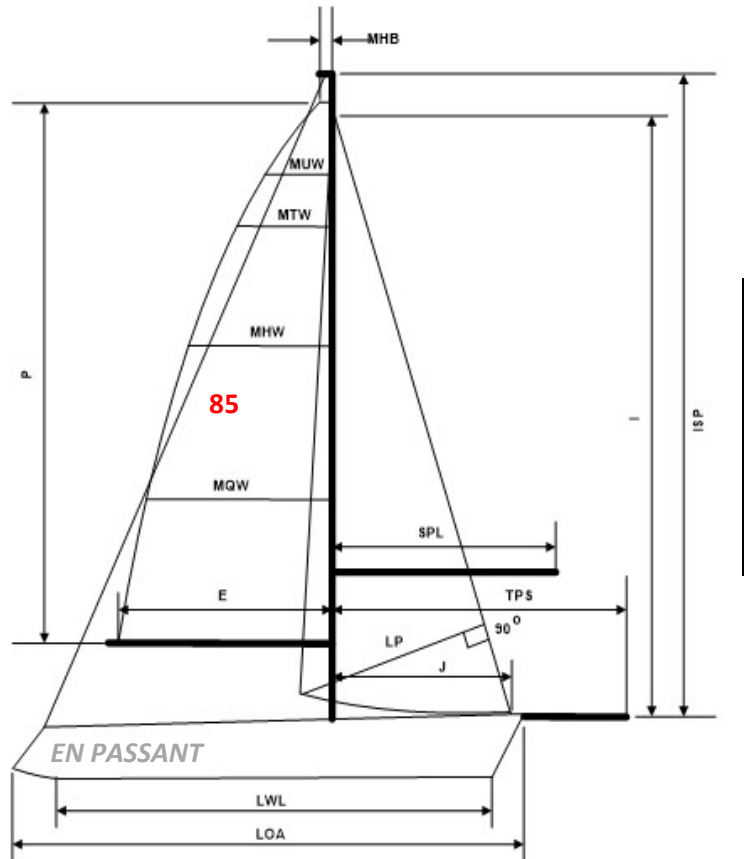

HANDICAP ADJUSTMENTS

Adjustments must be requested by the owner and are only made based on visual inspection and/or physical measurement by an authorized PHRF-SS measurer.

Owner Signature: _____

My signature attests to the fact that all the information contained on this certificate is true and correct to the best of my knowledge and that I have not made any modifications to the boat which have not been reported to PHRF-SS.

Certificate Issue: 3/1/2026

Certificate Expires: 3/31/2027



SOUTH SHORE PHRF HANDICAP CERTIFICATE 2026

PHRF-SS, LLC., PO Box 347021, Cleveland, OH 44134

<http://phrfss.org>

HCP (Spinnaker): 69 sec/nm
NSP (Non-Spinnaker): 79 sec/nm
PPF (Perf Prediction Factor): 8.18
TCF (Time Correction Factor): 1.0936
CRWT (Crew Weight Limit): 2143 LBS.

YACHT NAME: THREE SWEETS
DESIGN: J-109
OWNER: Anne Richman
CERTIFICATE: **STND**
CLASSIFICATION: DISP
SAIL NO: 283
POWER: IB
YACHT CLUB: LYC

LOA: 35 FT.
LWL: 31 FT.
BEAM: 12 FT.
DRAFT: 7.00 FT.
DISPLACEMENT: 10900 LBS.
BALLAST: 3900 LBS.
SAIL AREA: 644 SQ. FT.
THS: 7.40 KN.

I: 46.50 FT.
ISP: 49.60 FT.
J: 13.30 FT.
JSP/TPS: 18.80 FT.
P: 43.25 FT.
E: 15.50 FT.

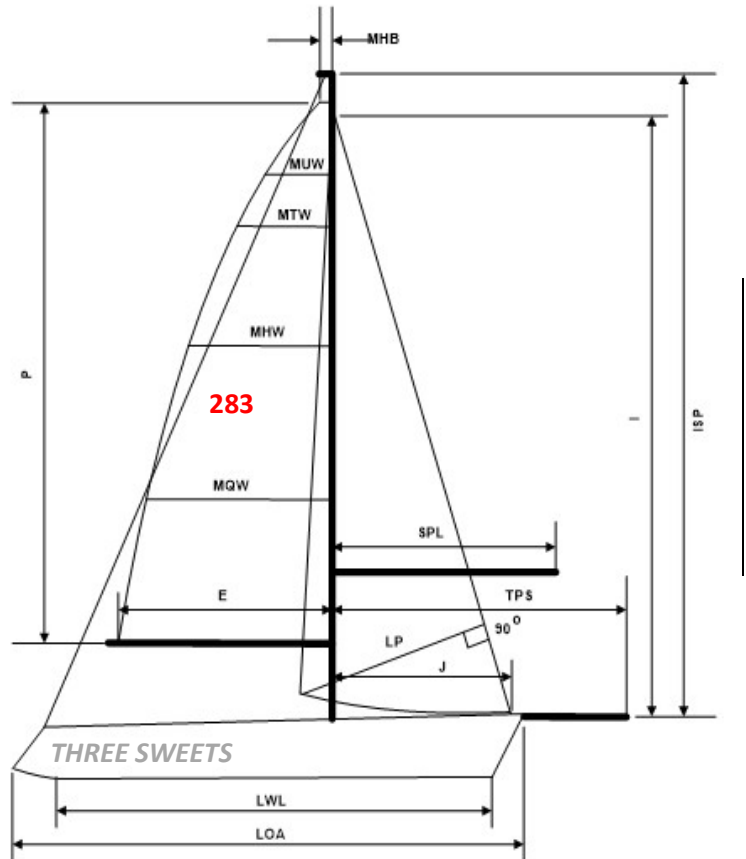

HANDICAP ADJUSTMENTS

Adjustments must be requested by the owner and are only made based on visual inspection and/or physical measurement by an authorized PHRF-SS measurer.

Owner Signature: _____

My signature attests to the fact that all the information contained on this certificate is true and correct to the best of my knowledge and that I have not made any modifications to the boat which have not been reported to PHRF-SS.

Certificate Issue: 5/5/2026

Certificate Expires: 3/31/2027



SOUTH SHORE PHRF HANDICAP CERTIFICATE 2026

PHRF-SS, LLC., PO Box 347021, Cleveland, OH 44134

<http://phrfss.org>

HCP (Spinnaker): 39 sec/nm
NSP (Non-Spinnaker): 50 sec/nm
PPF (Perf Prediction Factor): 5.04
TCF (Time Correction Factor): 1.1503
CRWT (Crew Weight Limit): 2230 LBS.

YACHT NAME: SPACEMAN SPIFF
DESIGN: J-111
OWNER: Rob Ruhlman
CERTIFICATE: ODR
CLASSIFICATION: HPRF
SAIL NO: 134
POWER: IB
YACHT CLUB: LYC

LOA: 36 FT.
LWL: 33 FT.
BEAM: 11 FT.
DRAFT: 7.18 FT.
DISPLACEMENT: 9370 LBS.
BALLAST: 3516 LBS.
SAIL AREA: 659 SQ. FT.
THS: 7.66 KN.

I: 47.74 FT.
ISP: 51.23 FT.
J: 13.85 FT.
JSP/TPS: 21.33 FT.
P: 45.24 FT.
E: 14.50 FT.

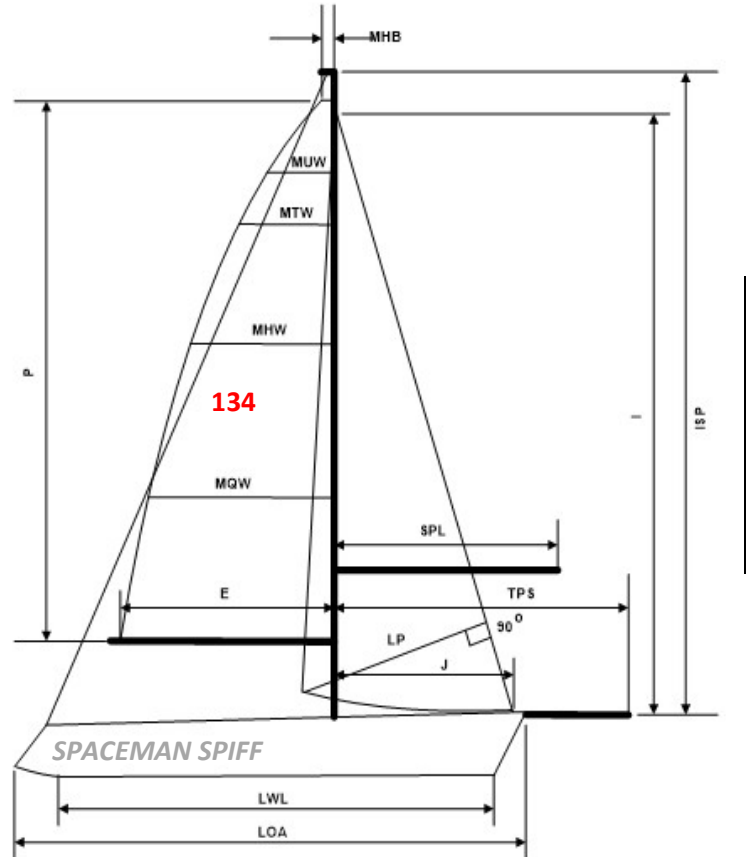

HANDICAP ADJUSTMENTS

106% JIB, 130 SQM (1399 SQ. FT)

Adjustments must be requested by the owner and are only made based on visual inspection and/or physical measurement by an authorized PHRF-SS measurer.

Owner Signature: _____

My signature attests to the fact that all the information contained on this certificate is true and correct to the best of my knowledge and that I have not made any modifications to the boat which have not been reported to PHRF-SS.

Certificate Issue: 3/5/2026

Certificate Expires: 3/31/2027



SOUTH SHORE PHRF HANDICAP CERTIFICATE 2026

PHRF-SS, LLC., PO Box 347021, Cleveland, OH 44134

<http://phrfss.org>

HCP (Spinnaker): 30 sec/nm
NSP (Non-Spinnaker): 39 sec/nm
PPF (Perf Prediction Factor): 5.73
TCF (Time Correction Factor): 1.1684
CRWT (Crew Weight Limit): 2414 LBS.

YACHT NAME: RUSH
DESIGN: FARR 395
OWNER: Laurence Rush
CERTIFICATE: **STND**
CLASSIFICATION: DISP
SAIL NO: 39516
POWER: IB
YACHT CLUB: FCYC

LOA: 39.40 FT.
LWL: 34.12 FT.
BEAM: 12.16 FT.
DRAFT: 7.81 FT.
DISPLACEMENT: 12500 LBS.
BALLAST: 4580 LBS.
SAIL AREA: 826 SQ. FT.
THS: 7.83 KN.

I: 51.25 FT.
ISP: 56.89 FT.
J: 14.04 FT.
JSP/TPS: 20.41 FT.
P: 50.45 FT.
E: 18.47 FT.

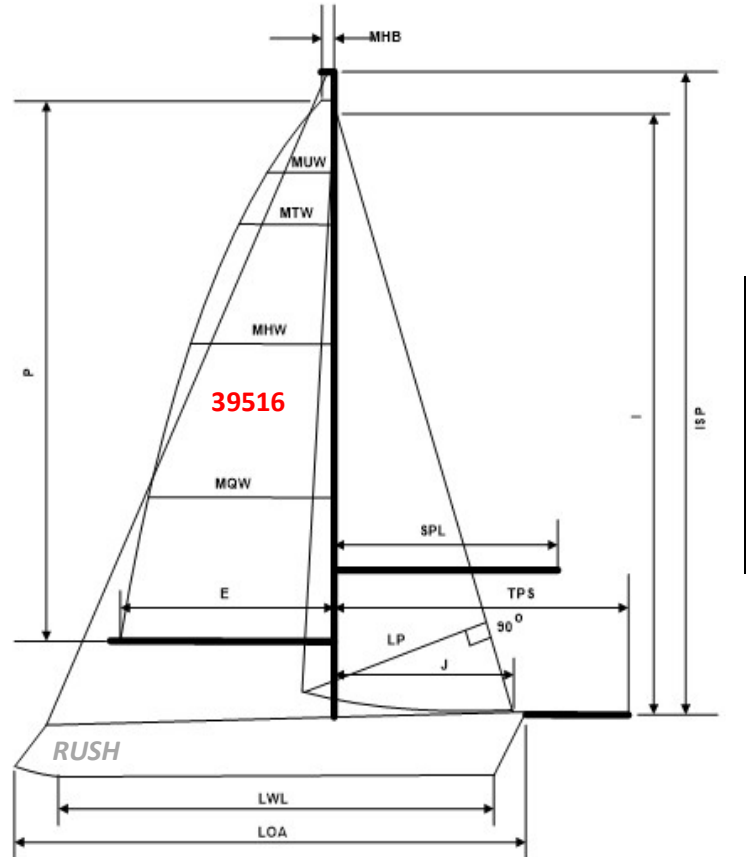

HANDICAP ADJUSTMENTS

Rated with a Code Zero

Adjustments must be requested by the owner and are only made based on visual inspection and/or physical measurement by an authorized PHRF-SS measurer.

Owner Signature: _____

My signature attests to the fact that all the information contained on this certificate is true and correct to the best of my knowledge and that I have not made any modifications to the boat which have not been reported to PHRF-SS.

Certificate Issue: 2/16/2026

Certificate Expires: 3/31/2027



SOUTH SHORE PHRF HANDICAP CERTIFICATE 2026

PHRF-SS, LLC., PO Box 347021, Cleveland, OH 44134

<http://phrfss.org>

HCP (Spinnaker): 147 sec/nm
NSP (Non-Spinnaker): 157 sec/nm
PPF (Perf Prediction Factor): 12.44
TCF (Time Correction Factor): 0.9694
CRWT (Crew Weight Limit): 1957 LBS.

YACHT NAME: LOTTE ROSE
DESIGN: CAT 34 MK II
OWNER: Bob Savinell
CERTIFICATE: **STND**
CLASSIFICATION: DISP
SAIL NO: 1312
POWER: IB
YACHT CLUB: EWYC

LOA: 35 FT.
LWL: 30 FT.
BEAM: 12 FT.
DRAFT: 5.58 FT.
DISPLACEMENT: 11950 LBS.
BALLAST: 5000 LBS.
SAIL AREA: 528 SQ. FT.
THS: 7.32 KN.

I: 44.00 FT.
ISP: 44.00 FT.
J: 13.50 FT.
JSP/TPS: 13.50 FT.
P: 38.50 FT.
E: 12.00 FT.

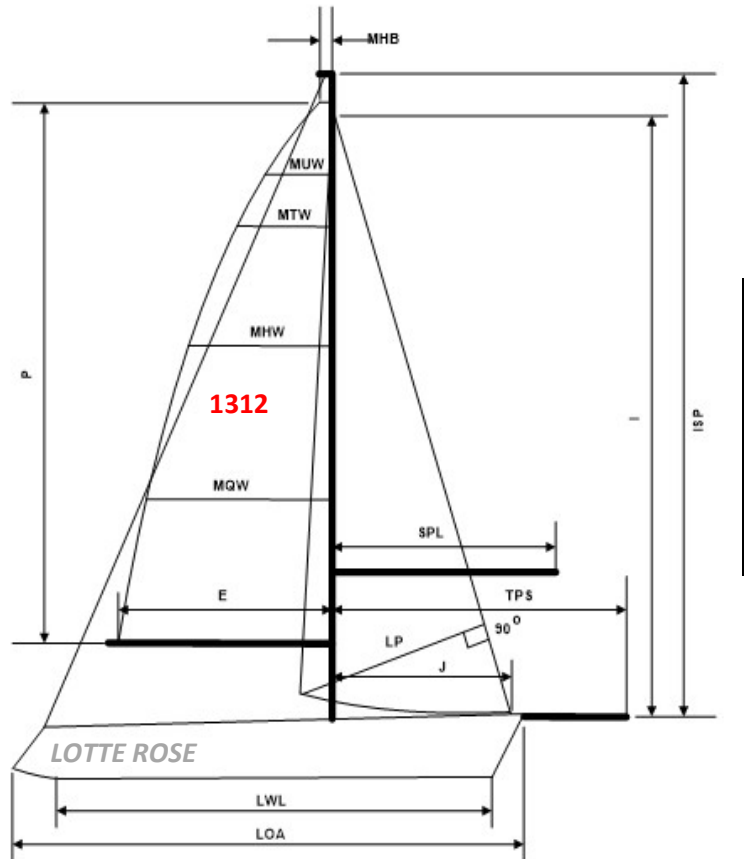

HANDICAP ADJUSTMENTS

Adjustments must be requested by the owner and are only made based on visual inspection and/or physical measurement by an authorized PHRF-SS measurer.

Owner Signature: _____

My signature attests to the fact that all the information contained on this certificate is true and correct to the best of my knowledge and that I have not made any modifications to the boat which have not been reported to PHRF-SS.

Certificate Issue: 3/12/2026

Certificate Expires: 3/31/2027



SOUTH SHORE PHRF HANDICAP CERTIFICATE 2026

PHRF-SS, LLC., PO Box 347021, Cleveland, OH 44134

<http://phrfss.org>

HCP (Spinnaker): 90 sec/nm
NSP (Non-Spinnaker): 100 sec/nm
PPF (Perf Prediction Factor): 6.77
TCF (Time Correction Factor): 1.0571
CRWT (Crew Weight Limit): 2061 LBS.

YACHT NAME: FALL LINE
DESIGN: J-105 ODR
OWNER: Chip Schaffner
CERTIFICATE: STND
CLASSIFICATION: DISP
SAIL NO: 144
POWER: IB
YACHT CLUB: EWYC

LOA: 35 FT.
LWL: 30 FT.
BEAM: 11 FT.
DRAFT: 6.50 FT.
DISPLACEMENT: 8575 LBS.
BALLAST: 3400 LBS.
SAIL AREA: 577 SQ. FT.
THS: 7.28 KN.

I: 40.60 FT.
ISP: 42.10 FT.
J: 13.50 FT.
JSP/TPS: 19.00 FT.
P: 41.50 FT.
E: 14.60 FT.

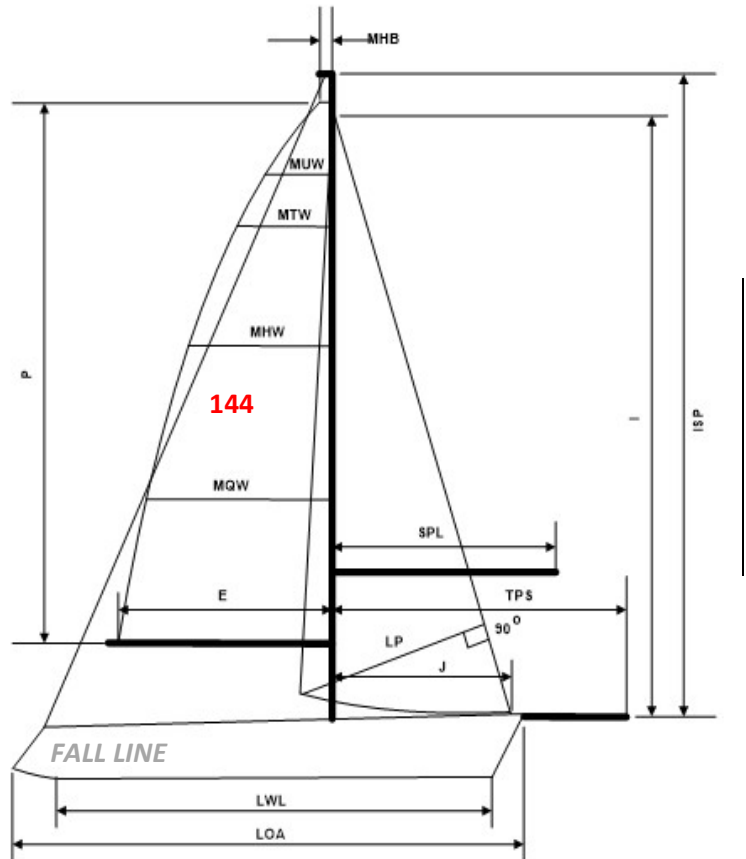

HANDICAP ADJUSTMENTS

ODR 102% JIB/89 SQM ASYM

Adjustments must be requested by the owner and are only made based on visual inspection and/or physical measurement by an authorized PHRF-SS measurer.

Owner Signature: _____

My signature attests to the fact that all the information contained on this certificate is true and correct to the best of my knowledge and that I have not made any modifications to the boat which have not been reported to PHRF-SS.

Certificate Issue: 3/1/2026

Certificate Expires: 3/31/2027



SOUTH SHORE PHRF HANDICAP CERTIFICATE 2026

PHRF-SS, LLC., PO Box 347021, Cleveland, OH 44134

<http://phrfss.org>

HCP (Spinnaker): 39 sec/nm
NSP (Non-Spinnaker): 50 sec/nm
PPF (Perf Prediction Factor): 5.04
TCF (Time Correction Factor): 1.1503
CRWT (Crew Weight Limit): 2230 LBS.

YACHT NAME: PAPA'S TOY
DESIGN: J-111
OWNER: Hugh Scott Seaholm
CERTIFICATE: ODR
CLASSIFICATION: HPRF
SAIL NO: 93
POWER: IB
YACHT CLUB: MHYC

LOA: 36 FT.
LWL: 33 FT.
BEAM: 11 FT.
DRAFT: 7.18 FT.
DISPLACEMENT: 9370 LBS.
BALLAST: 3516 LBS.
SAIL AREA: 659 SQ. FT.
THS: 7.66 KN.

I: 47.74 FT.
ISP: 51.23 FT.
J: 13.85 FT.
JSP/TPS: 21.33 FT.
P: 45.24 FT.
E: 14.50 FT.

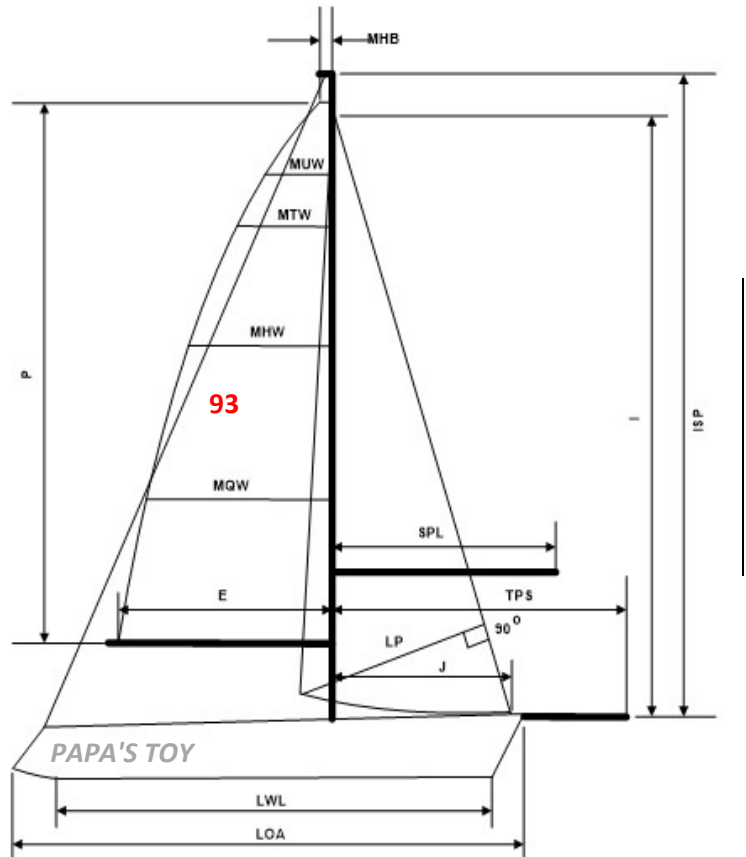

HANDICAP ADJUSTMENTS

106% JIB, 130 SQM (1399 SQ. FT)

Adjustments must be requested by the owner and are only made based on visual inspection and/or physical measurement by an authorized PHRF-SS measurer.

Owner Signature: _____

My signature attests to the fact that all the information contained on this certificate is true and correct to the best of my knowledge and that I have not made any modifications to the boat which have not been reported to PHRF-SS.

Certificate Issue: 2/26/2026

Certificate Expires: 3/31/2027



SOUTH SHORE PHRF HANDICAP CERTIFICATE 2026

PHRF-SS, LLC., PO Box 347021, Cleveland, OH 44134

<http://phrfss.org>

HCP (Spinnaker): -84 sec/nm
NSP (Non-Spinnaker): -75 sec/nm
PPF (Perf Prediction Factor): 1.91
TCF (Time Correction Factor): 1.4605
CRWT (Crew Weight Limit): 3260 LBS.

YACHT NAME: HOOLIGAN
DESIGN: TRANSPAC 52 JV
OWNER: Trey Sheehan
CERTIFICATE: **STND**
CLASSIFICATION: HPRF
SAIL NO: 52521
POWER: IB
YACHT CLUB: EWYC

LOA: 52 FT.
LWL: 49 FT.
BEAM: 15 FT.
DRAFT: 10.58 FT.
DISPLACEMENT: 17150 LBS.
BALLAST: 7393 LBS.
SAIL AREA: 1436 SQ. FT.
THS: 9.36 KN.

I: 64.38 FT.
ISP: 74.07 FT.
J: 20.36 FT.
JSP/TPS: 28.95 FT.
P: 67.03 FT.
E: 23.29 FT.

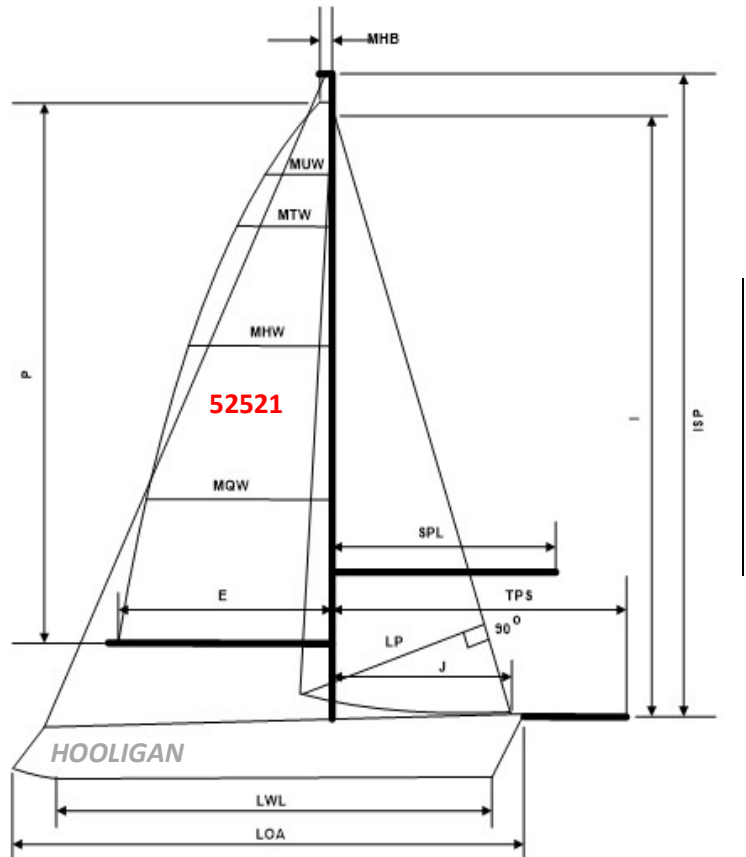

HANDICAP ADJUSTMENTS

Adjustments must be requested by the owner and are only made based on visual inspection and/or physical measurement by an authorized PHRF-SS measurer.

Owner Signature: _____

My signature attests to the fact that all the information contained on this certificate is true and correct to the best of my knowledge and that I have not made any modifications to the boat which have not been reported to PHRF-SS.

Certificate Issue: 6/2/2026

Certificate Expires: 3/31/2027



SOUTH SHORE PHRF HANDICAP CERTIFICATE 2026

PHRF-SS, LLC., PO Box 347021, Cleveland, OH 44134

<http://phrfss.org>

HCP (Spinnaker): 90 sec/nm
NSP (Non-Spinnaker): 100 sec/nm
PPF (Perf Prediction Factor): 6.77
TCF (Time Correction Factor): 1.0571
CRWT (Crew Weight Limit): 2061 LBS.

YACHT NAME: TRIO
DESIGN: J-105 ODR
OWNER: Paul Uhler
CERTIFICATE: **STND**
CLASSIFICATION: DISP
SAIL NO: 91
POWER: IB
YACHT CLUB: EWYC

LOA: 35 FT.
LWL: 30 FT.
BEAM: 11 FT.
DRAFT: 6.50 FT.
DISPLACEMENT: 8575 LBS.
BALLAST: 3400 LBS.
SAIL AREA: 577 SQ. FT.
THS: 7.28 KN.

I: 40.60 FT.
ISP: 42.10 FT.
J: 13.50 FT.
JSP/TPS: 19.00 FT.
P: 41.50 FT.
E: 14.60 FT.

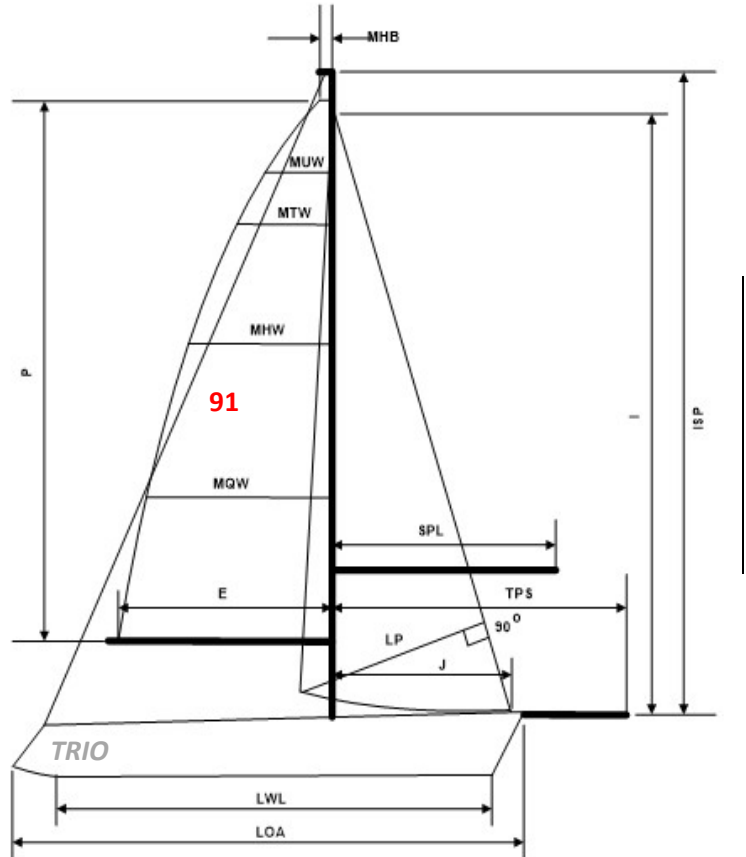

HANDICAP ADJUSTMENTS

ODR 102% JIB/89 SQM ASYM

Adjustments must be requested by the owner and are only made based on visual inspection and/or physical measurement by an authorized PHRF-SS measurer.

Owner Signature: _____

My signature attests to the fact that all the information contained on this certificate is true and correct to the best of my knowledge and that I have not made any modifications to the boat which have not been reported to PHRF-SS.

Certificate Issue: 3/5/2026

Certificate Expires: 3/31/2027



SOUTH SHORE PHRF HANDICAP CERTIFICATE 2026

PHRF-SS, LLC., PO Box 347021, Cleveland, OH 44134

<http://phrfss.org>

HCP (Spinnaker): 105 sec/nm
NSP (Non-Spinnaker): 113 sec/nm
PPF (Perf Prediction Factor): 9.94
TCF (Time Correction Factor): 1.0326
CRWT (Crew Weight Limit): 2746 LBS.

YACHT NAME: HUMA
DESIGN: JEAN 50 DS SD
OWNER: Marc Uhrich
CERTIFICATE: **STND**
CLASSIFICATION: DISP
SAIL NO: 50
POWER: IB
YACHT CLUB: EWYC

LOA: 49 FT.
LWL: 43 FT.
BEAM: 15 FT.
DRAFT: 5.54 FT.
DISPLACEMENT: 29542 LBS.
BALLAST: 9038 LBS.
SAIL AREA: 994 SQ. FT.
THS: 8.79 KN.

I: 55.77 FT.
ISP: 55.77 FT.
J: 18.63 FT.
JSP/TPS: 18.63 FT.
P: 51.67 FT.
E: 18.37 FT.

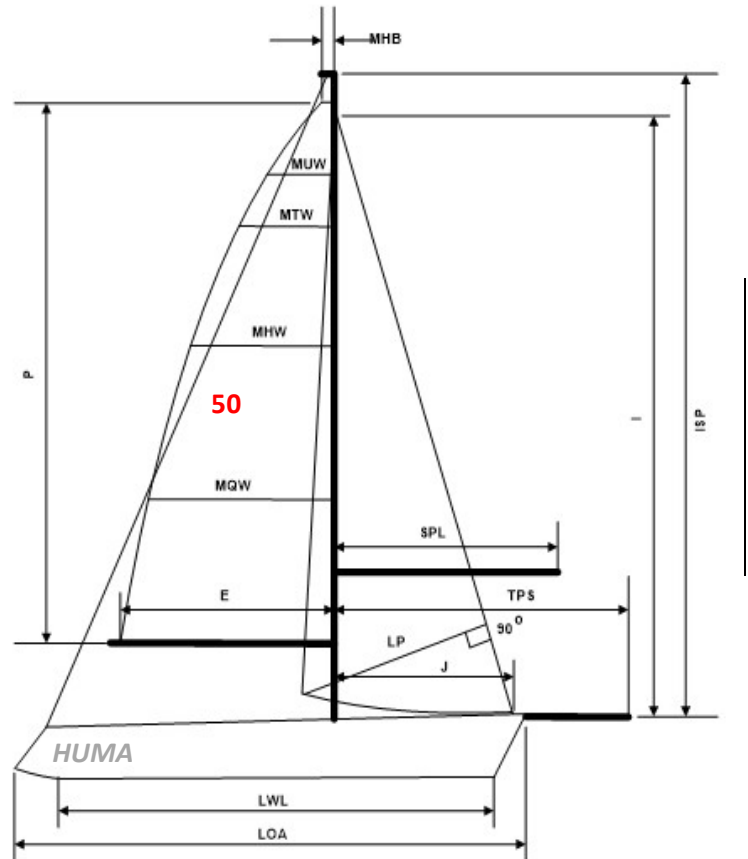

HANDICAP ADJUSTMENTS

+3 RFG / +9 RFM / 100% Asym declared

Adjustments must be requested by the owner and are only made based on visual inspection and/or physical measurement by an authorized PHRF-SS measurer.

Owner Signature: _____

My signature attests to the fact that all the information contained on this certificate is true and correct to the best of my knowledge and that I have not made any modifications to the boat which have not been reported to PHRF-SS.

Certificate Issue: 5/19/2026

Certificate Expires: 3/31/2027



SOUTH SHORE PHRF HANDICAP CERTIFICATE 2026

PHRF-SS, LLC., PO Box 347021, Cleveland, OH 44134

<http://phrfss.org>

HCP (Spinnaker): 15 sec/nm
NSP (Non-Spinnaker): 24 sec/nm
PPF (Perf Prediction Factor): 1.99
TCF (Time Correction Factor): 1.2000
CRWT (Crew Weight Limit): 2062 LBS.

YACHT NAME: TEAM VANPIRE
DESIGN: MELGES 32 ODR
OWNER: Willem van Heeckeren
CERTIFICATE: **STND**
CLASSIFICATION: HPRF
SAIL NO: 235
POWER: IB
YACHT CLUB: EWYC

LOA: 32 FT.
LWL: 29 FT.
BEAM: 10 FT.
DRAFT: 7.00 FT.
DISPLACEMENT: 3774 LBS.
BALLAST: 1570 LBS.
SAIL AREA: 554 SQ. FT.
THS: 7.15 KN.

I: 39.90 FT.
ISP: 48.20 FT.
J: 10.80 FT.
JSP/TPS: 19.43 FT.
P: 44.00 FT.
E: 15.40 FT.

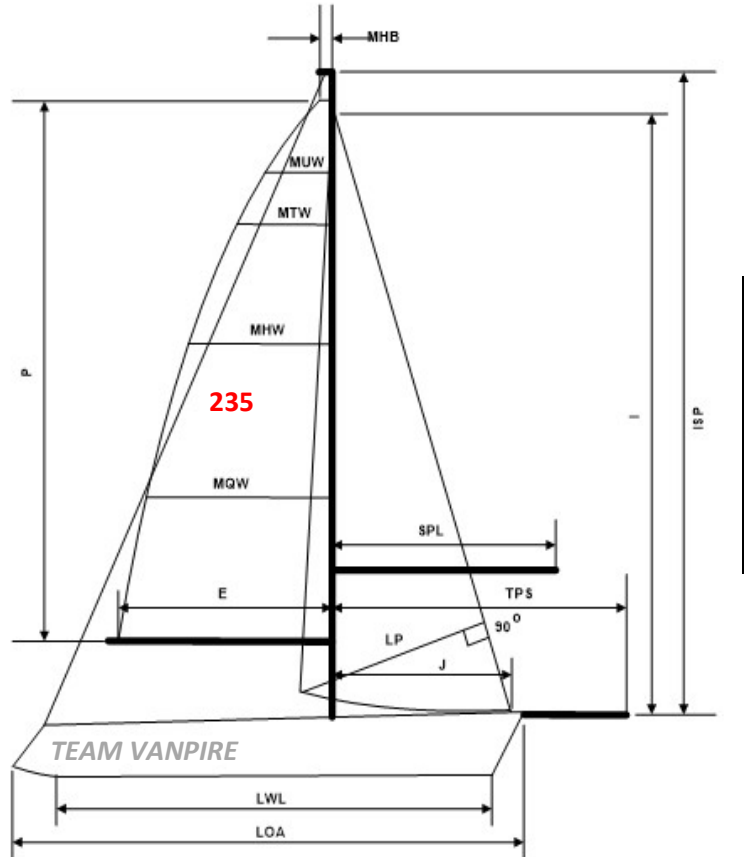

HANDICAP ADJUSTMENTS

104% JIB / 103SQM - 121SQM

Adjustments must be requested by the owner and are only made based on visual inspection and/or physical measurement by an authorized PHRF-SS measurer.

Owner Signature: _____

My signature attests to the fact that all the information contained on this certificate is true and correct to the best of my knowledge and that I have not made any modifications to the boat which have not been reported to PHRF-SS.

Certificate Issue: 5/31/2026

Certificate Expires: 3/31/2027



SOUTH SHORE PHRF HANDICAP CERTIFICATE 2026

PHRF-SS, LLC., PO Box 347021, Cleveland, OH 44134

<http://phrfss.org>

HCP (Spinnaker): 186 sec/nm
NSP (Non-Spinnaker): 196 sec/nm
PPF (Perf Prediction Factor): 17.12
TCF (Time Correction Factor): 0.9174
CRWT (Crew Weight Limit): 1714 LBS.

YACHT NAME: INTO THE MYSTIC
DESIGN: S2 9.2A
OWNER: Timothy Vining
CERTIFICATE: **STND**
CLASSIFICATION: DISP
SAIL NO: 25344
POWER: IB
YACHT CLUB: EWYC

LOA: 30 FT.
LWL: 25 FT.
BEAM: 10 FT.
DRAFT: 4.92 FT.
DISPLACEMENT: 9800 LBS.
BALLAST: 4000 LBS.
SAIL AREA: 468 SQ. FT.
THS: 6.70 KN.

I: 40.00 FT.
ISP: 40.00 FT.
J: 13.00 FT.
JSP/TPS: 13.00 FT.
P: 34.00 FT.
E: 12.25 FT.

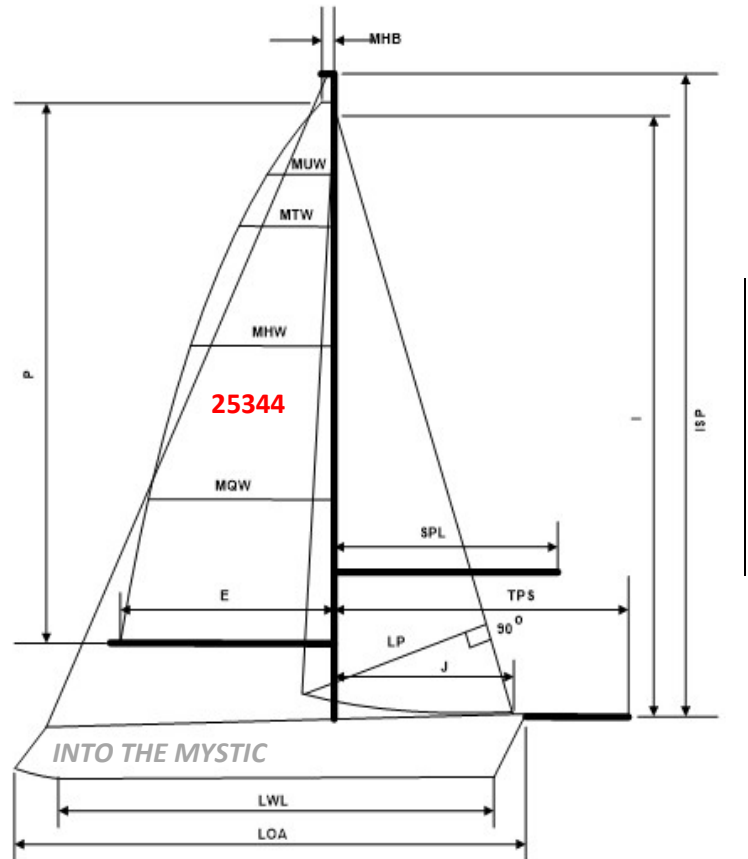

HANDICAP ADJUSTMENTS

+3RFG / +9 3BX

Adjustments must be requested by the owner and are only made based on visual inspection and/or physical measurement by an authorized PHRF-SS measurer.

Owner Signature: _____

My signature attests to the fact that all the information contained on this certificate is true and correct to the best of my knowledge and that I have not made any modifications to the boat which have not been reported to PHRF-SS.

Certificate Issue: 5/25/2026

Certificate Expires: 3/31/2027



SOUTH SHORE PHRF HANDICAP CERTIFICATE 2026

PHRF-SS, LLC., PO Box 347021, Cleveland, OH 44134

<http://phrfss.org>

HCP (Spinnaker): 150 sec/nm
NSP (Non-Spinnaker): 156 sec/nm
PPF (Perf Prediction Factor): 9.61
TCF (Time Correction Factor): 0.9652
CRWT (Crew Weight Limit): 1763 LBS.

YACHT NAME: RUBBER SOUL
DESIGN: J-30
OWNER: Doug Wahl
CERTIFICATE: **STND**
CLASSIFICATION: DISP
SAIL NO: 23523
POWER: IB
YACHT CLUB: EWYC

LOA: 30 FT.
LWL: 25 FT.
BEAM: 11 FT.
DRAFT: 5.25 FT.
DISPLACEMENT: 6700 LBS.
BALLAST: 2100 LBS.
SAIL AREA: 443 SQ. FT.
THS: 6.70 KN.

I: 34.00 FT.
ISP: 34.19 FT.
J: 11.50 FT.
JSP/TPS: 12.50 FT.
P: 38.00 FT.
E: 13.00 FT.

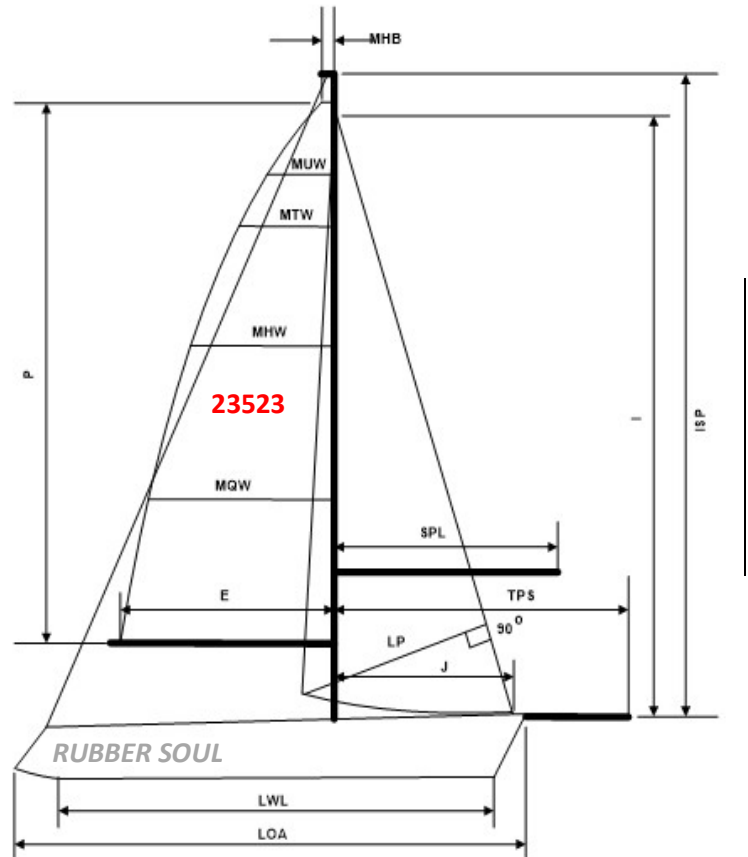

HANDICAP ADJUSTMENTS

+3 RFG

Adjustments must be requested by the owner and are only made based on visual inspection and/or physical measurement by an authorized PHRF-SS measurer.

Owner Signature: _____

My signature attests to the fact that all the information contained on this certificate is true and correct to the best of my knowledge and that I have not made any modifications to the boat which have not been reported to PHRF-SS.

Certificate Issue: 6/3/2026

Certificate Expires: 3/31/2027



SOUTH SHORE PHRF HANDICAP CERTIFICATE 2026

PHRF-SS, LLC., PO Box 347021, Cleveland, OH 44134

<http://phrfss.org>

HCP (Spinnaker): 48 sec/nm
NSP (Non-Spinnaker): 58 sec/nm
PPF (Perf Prediction Factor): 7.00
TCF (Time Correction Factor): 1.1327
CRWT (Crew Weight Limit): 2393 LBS.

YACHT NAME: VIVA LA VIDA
DESIGN: J-120 AL ODR
OWNER: Tim Yanda
CERTIFICATE: **ODR**
CLASSIFICATION: DISP
SAIL NO: 46722
POWER: IB
YACHT CLUB: EWYC

LOA: 40 FT.
LWL: 35 FT.
BEAM: 12 FT.
DRAFT: 7.00 FT.
DISPLACEMENT: 13900 LBS.
BALLAST: 6000 LBS.
SAIL AREA: 780 SQ. FT.
THS: 7.87 KN.

I: 50.50 FT.
ISP: 52.00 FT.
J: 14.50 FT.
JSP/TPS: 21.50 FT.
P: 46.50 FT.
E: 17.80 FT.

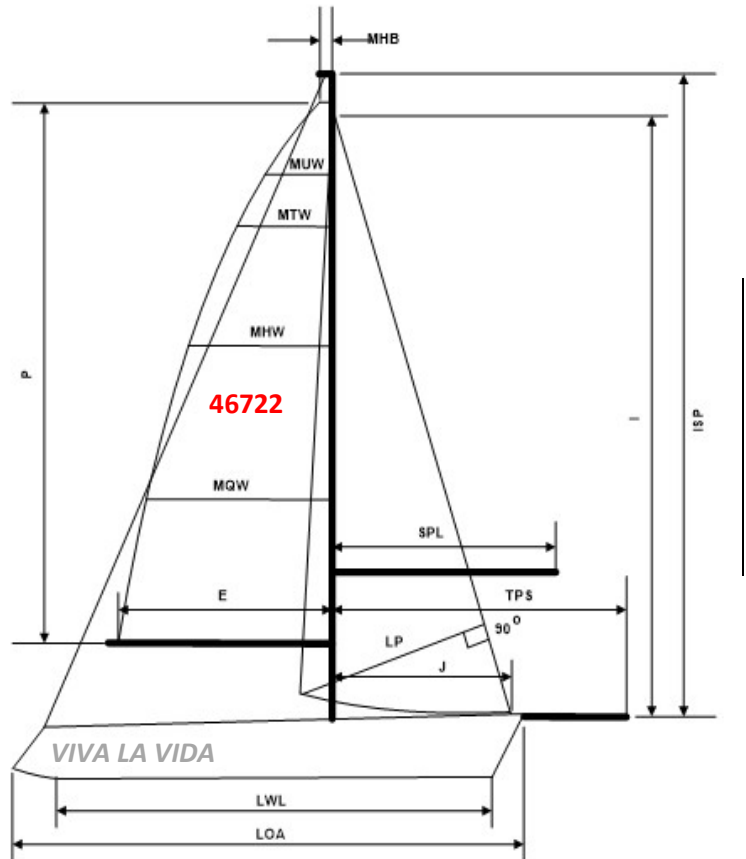

HANDICAP ADJUSTMENTS

Adjustments must be requested by the owner and are only made based on visual inspection and/or physical measurement by an authorized PHRF-SS measurer.

Owner Signature: _____

My signature attests to the fact that all the information contained on this certificate is true and correct to the best of my knowledge and that I have not made any modifications to the boat which have not been reported to PHRF-SS.

Certificate Issue: 3/12/2026

Certificate Expires: 3/31/2027



SOUTH SHORE PHRF HANDICAP CERTIFICATE 2026

PHRF-SS, LLC., PO Box 347021, Cleveland, OH 44134

<http://phrfss.org>

HCP (Spinnaker): 39 sec/nm
NSP (Non-Spinnaker): 50 sec/nm
PPF (Perf Prediction Factor): 5.04
TCF (Time Correction Factor): 1.1503
CRWT (Crew Weight Limit): 2230 LBS.

YACHT NAME: BLACK SEAL
DESIGN: J-111
OWNER: Seth Young
CERTIFICATE: ODR
CLASSIFICATION: HPRF
SAIL NO: 111
POWER: IB
YACHT CLUB: LYC

LOA: 36 FT.
LWL: 33 FT.
BEAM: 11 FT.
DRAFT: 7.18 FT.
DISPLACEMENT: 9370 LBS.
BALLAST: 3516 LBS.
SAIL AREA: 659 SQ. FT.
THS: 7.66 KN.

I: 47.74 FT.
ISP: 51.23 FT.
J: 13.85 FT.
JSP/TPS: 21.33 FT.
P: 45.24 FT.
E: 14.50 FT.

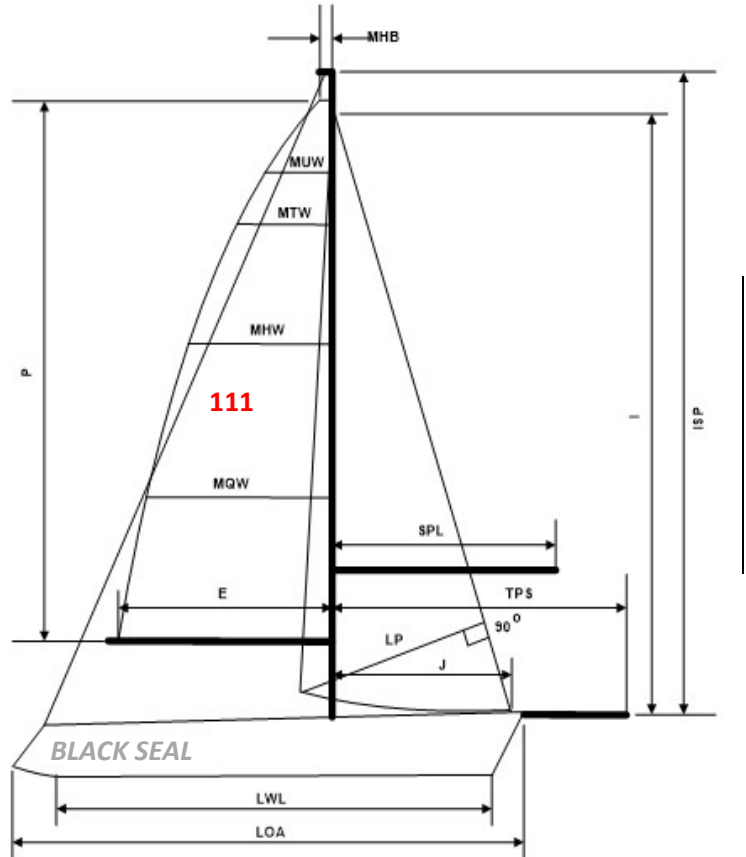

HANDICAP ADJUSTMENTS

106% JIB, 130 SQM (1399 SQ. FT)

Adjustments must be requested by the owner and are only made based on visual inspection and/or physical measurement by an authorized PHRF-SS measurer.

Owner Signature: _____

My signature attests to the fact that all the information contained on this certificate is true and correct to the best of my knowledge and that I have not made any modifications to the boat which have not been reported to PHRF-SS.

Certificate Issue: 3/22/2026

Certificate Expires: 3/31/2027