



# SOUTH SHORE PHRF HANDICAP CERTIFICATE 2026

PHRF-SS, LLC., PO Box 347021, Cleveland, OH 44134

<http://phrfss.org>

**HCP (Spinnaker):** 72 sec/nm  
**NSP (Non-Spinnaker):** 81 sec/nm  
**PPF (Perf Prediction Factor):** 6.70  
**TCF (Time Correction Factor):** 1.0882  
**CRWT (Crew Weight Limit):** 2201 LBS.

**YACHT NAME:** OUTLET XPRESS  
**DESIGN:** EXPRESS 37  
**OWNER:** Ken Block  
**CERTIFICATE:** **STND**  
**CLASSIFICATION:** DISP  
**SAIL NO:** 41046  
**POWER:** IB  
**YACHT CLUB:** EWYC

**LOA:** 37.08 FT.  
**LWL:** 30.83 FT.  
**BEAM:** 11.50 FT.  
**DRAFT:** 7.25 FT.  
**DISPLACEMENT:** 9800 LBS.  
**BALLAST:** 4600 LBS.  
**SAIL AREA:** 638 SQ. FT.  
**THS:** 7.44 KN.

**I:** 48.75 FT.  
**ISP:** 48.75 FT.  
**J:** 14.33 FT.  
**JSP/TPS:** 14.33 FT.  
**P:** 42.00 FT.  
**E:** 13.75 FT.

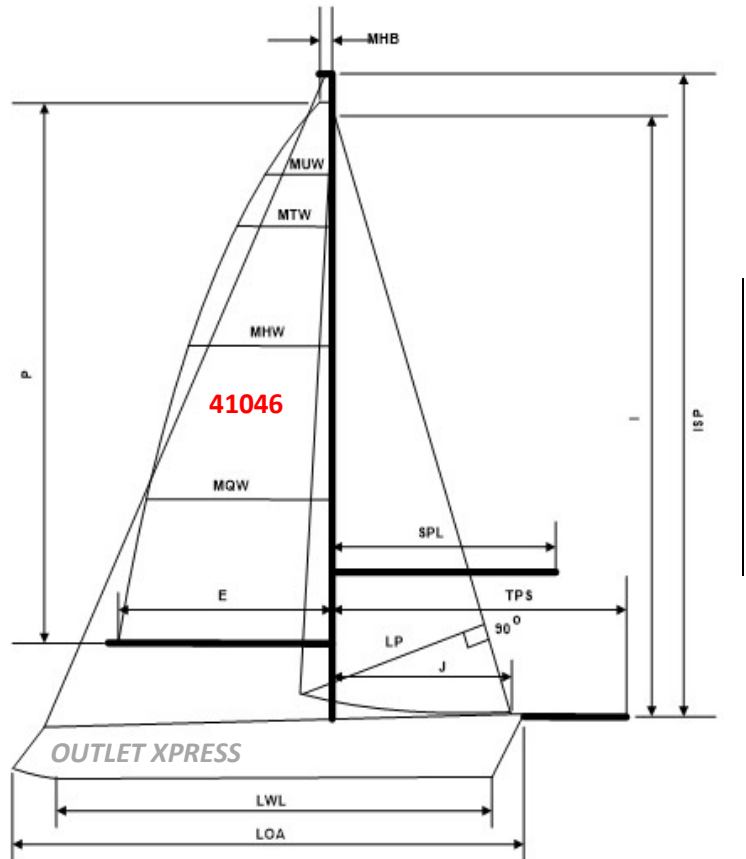

## HANDICAP ADJUSTMENTS

*Adjustments must be requested by the owner and are only made based on visual inspection and/or physical measurement by an authorized PHRF-SS measurer.*

Owner Signature: \_\_\_\_\_

*My signature attests to the fact that all the information contained on this certificate is true and correct to the best of my knowledge and that I have not made any modifications to the boat which have not been reported to PHRF-SS.*

**Certificate Issue: 3/1/2026**

**Certificate Expires: 3/31/2027**



# SOUTH SHORE PHRF HANDICAP CERTIFICATE 2026

PHRF-SS, LLC., PO Box 347021, Cleveland, OH 44134

<http://phrfss.org>

**HCP (Spinnaker):** 150 sec/nm  
**NSP (Non-Spinnaker):** 156 sec/nm  
**PPF (Perf Prediction Factor):** 9.61  
**TCF (Time Correction Factor):** 0.9652  
**CRWT (Crew Weight Limit):** 1763 LBS.

**YACHT NAME:** SOLIDARITY  
**DESIGN:** J-30  
**OWNER:** Paul Blonski  
**CERTIFICATE:** **STND**  
**CLASSIFICATION:** DISP  
**SAIL NO:** 84  
**POWER:** IB  
**YACHT CLUB:** EWYC

**LOA:** 30 FT.  
**LWL:** 25 FT.  
**BEAM:** 11 FT.  
**DRAFT:** 5.25 FT.  
**DISPLACEMENT:** 6700 LBS.  
**BALLAST:** 2100 LBS.  
**SAIL AREA:** 443 SQ. FT.  
**THS:** 6.70 KN.

**I:** 34.00 FT.  
**ISP:** 34.19 FT.  
**J:** 11.50 FT.  
**JSP/TPS:** 12.50 FT.  
**P:** 38.00 FT.  
**E:** 13.00 FT.

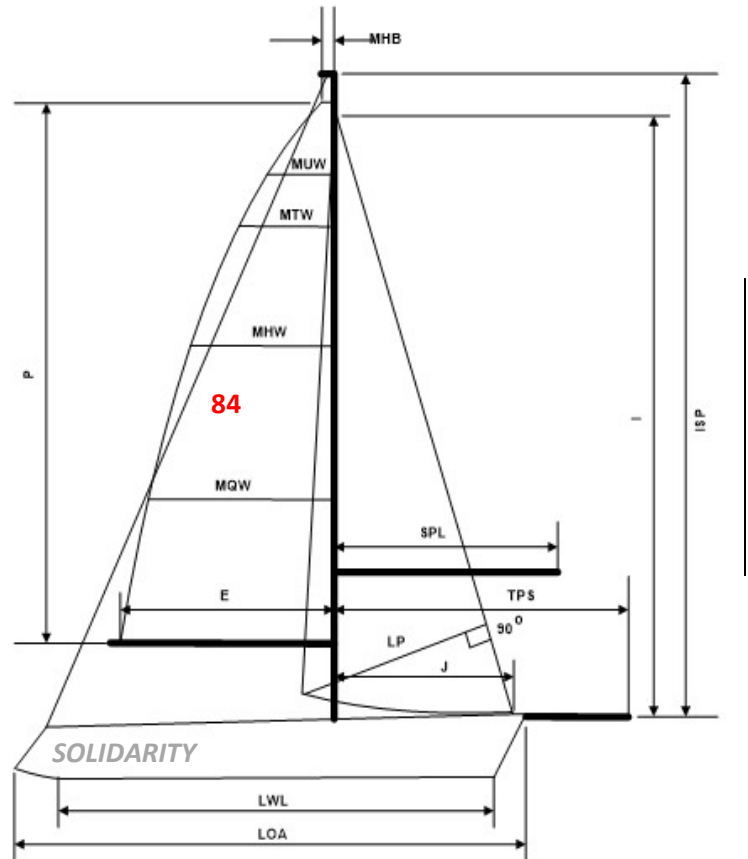

## HANDICAP ADJUSTMENTS

+3 RFG

*Adjustments must be requested by the owner and are only made based on visual inspection and/or physical measurement by an authorized PHRF-SS measurer.*

Owner Signature: \_\_\_\_\_

*My signature attests to the fact that all the information contained on this certificate is true and correct to the best of my knowledge and that I have not made any modifications to the boat which have not been reported to PHRF-SS.*

**Certificate Issue: 3/1/2026**

**Certificate Expires: 3/31/2027**



# SOUTH SHORE PHRF HANDICAP CERTIFICATE 2026

PHRF-SS, LLC., PO Box 347021, Cleveland, OH 44134

<http://phrfss.org>

**HCP (Spinnaker):** 96 sec/nm  
**NSP (Non-Spinnaker):** 104 sec/nm  
**PPF (Perf Prediction Factor):** 11.47  
**TCF (Time Correction Factor):** 1.0472  
**CRWT (Crew Weight Limit):** 2384 LBS.

**YACHT NAME:** VOYAGER  
**DESIGN:** TARTAN 4100 TM SD  
**OWNER:** Hunter Chisholm  
**CERTIFICATE:** **STND**  
**CLASSIFICATION:** DISP  
**SAIL NO:** 4100  
**POWER:** IB  
**YACHT CLUB:** LYC

**LOA:** 41 FT.  
**LWL:** 36 FT.  
**BEAM:** 14 FT.  
**DRAFT:** 5.33 FT.  
**DISPLACEMENT:** 20400 LBS.  
**BALLAST:** 8000 LBS.  
**SAIL AREA:** 811 SQ. FT.  
**THS:** 8.01 KN.

**I:** 54.00 FT.  
**ISP:** 54.00 FT.  
**J:** 15.00 FT.  
**JSP/TPS:** 15.00 FT.  
**P:** 47.75 FT.  
**E:** 17.00 FT.

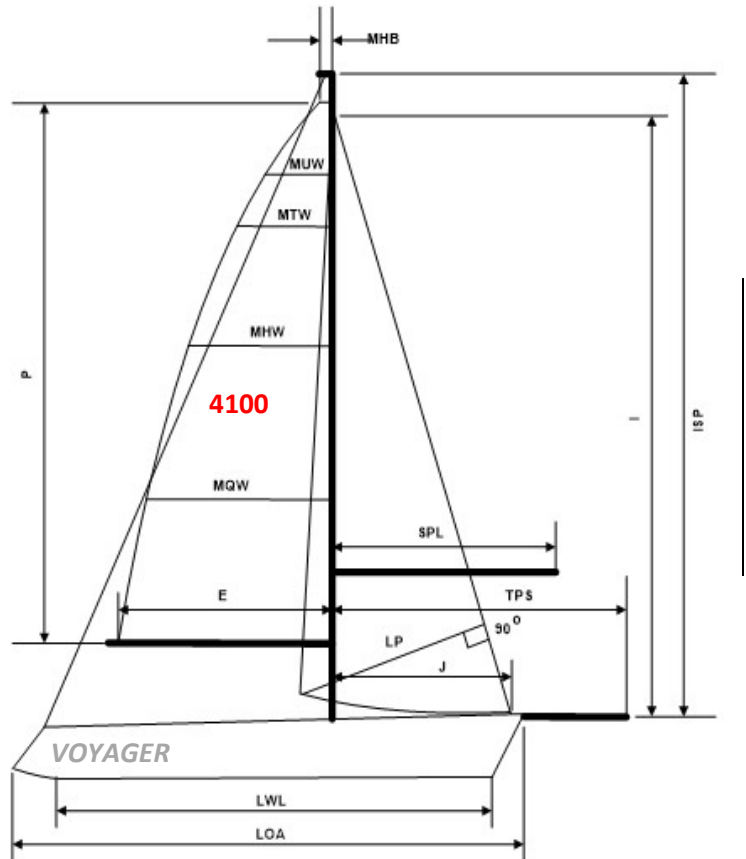

## HANDICAP ADJUSTMENTS

+3 RFG

*Adjustments must be requested by the owner and are only made based on visual inspection and/or physical measurement by an authorized PHRF-SS measurer.*

Owner Signature: \_\_\_\_\_

*My signature attests to the fact that all the information contained on this certificate is true and correct to the best of my knowledge and that I have not made any modifications to the boat which have not been reported to PHRF-SS.*

**Certificate Issue: 3/5/2026**

**Certificate Expires: 3/31/2027**



# SOUTH SHORE PHRF HANDICAP CERTIFICATE 2026

PHRF-SS, LLC., PO Box 347021, Cleveland, OH 44134

<http://phrfss.org>

**HCP (Spinnaker):** 141 sec/nm  
**NSP (Non-Spinnaker):** 150 sec/nm  
**PPF (Perf Prediction Factor):** 10.71  
**TCF (Time Correction Factor):** 0.9780  
**CRWT (Crew Weight Limit):** 2025 LBS.

**YACHT NAME:** CAN'T CONTAIN'ER  
**DESIGN:** TARTAN 3500 SD BT  
**OWNER:** Jane Colazzo  
**CERTIFICATE:** **STND**  
**CLASSIFICATION:** DISP  
**SAIL NO:** 91  
**POWER:** IB  
**YACHT CLUB:** EWYC

**LOA:** 35 FT.  
**LWL:** 30 FT.  
**BEAM:** 12 FT.  
**DRAFT:** 4.83 FT.  
**DISPLACEMENT:** 12100 LBS.  
**BALLAST:** 4900 LBS.  
**SAIL AREA:** 615 SQ. FT.  
**THS:** 7.34 KN.

**I:** 46.75 FT.  
**ISP:** 46.75 FT.  
**J:** 13.75 FT.  
**JSP/TPS:** 14.75 FT.  
**P:** 41.25 FT.  
**E:** 14.25 FT.

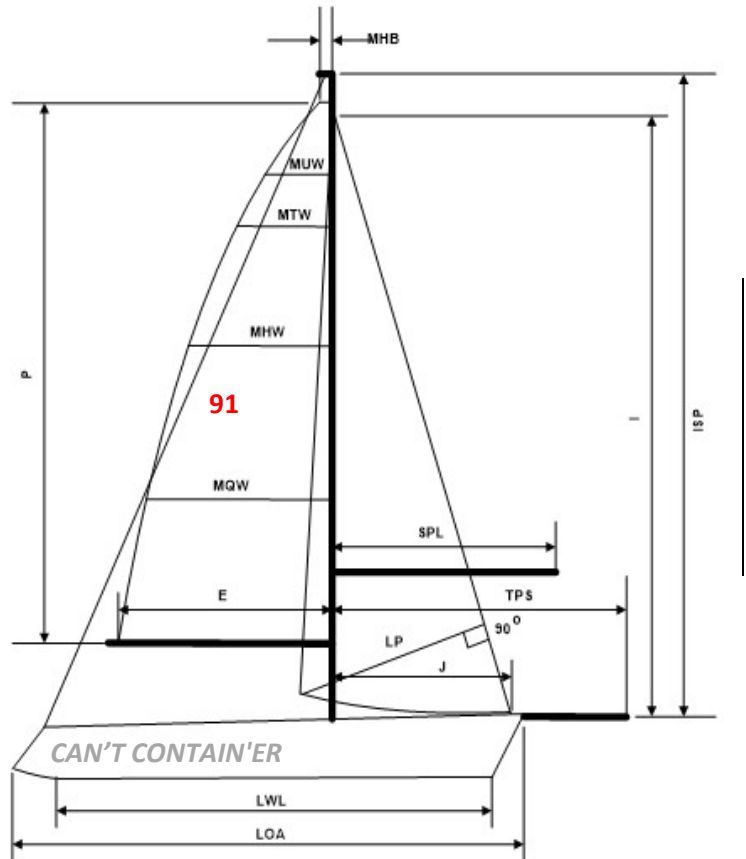

## HANDICAP ADJUSTMENTS

+6ASM / +9 3BX

*Adjustments must be requested by the owner and are only made based on visual inspection and/or physical measurement by an authorized PHRF-SS measurer.*

Owner Signature: \_\_\_\_\_

*My signature attests to the fact that all the information contained on this certificate is true and correct to the best of my knowledge and that I have not made any modifications to the boat which have not been reported to PHRF-SS.*

**Certificate Issue: 4/28/2026**

**Certificate Expires: 3/31/2027**



# SOUTH SHORE PHRF HANDICAP CERTIFICATE 2026

PHRF-SS, LLC., PO Box 347021, Cleveland, OH 44134

<http://phrfss.org>

**HCP (Spinnaker):** 96 sec/nm  
**NSP (Non-Spinnaker):** 106 sec/nm  
**PPF (Perf Prediction Factor):** 5.35  
**TCF (Time Correction Factor):** 1.0472  
**CRWT (Crew Weight Limit):** 1901 LBS.

**YACHT NAME:** TULA-TULA  
**DESIGN:** FIRST 30 (BENET) SPRIT  
**OWNER:** Mark Corson  
**CERTIFICATE:** PRLM  
**CLASSIFICATION:** DISP  
**SAIL NO:** 61939  
**POWER:** IB  
**YACHT CLUB:** EWYC

**LOA:** 31 FT.  
**LWL:** 29 FT.  
**BEAM:** 10 FT.  
**DRAFT:** 6.71 FT.  
**DISPLACEMENT:** 6702 LBS.  
**BALLAST:** 2359 LBS.  
**SAIL AREA:** 525 SQ. FT.  
**THS:** 7.18 KN.

**I:** 37.30 FT.  
**ISP:** 44.16 FT.  
**J:** 14.21 FT.  
**JSP/TPS:** 17.36 FT.  
**P:** 39.21 FT.  
**E:** 13.26 FT.

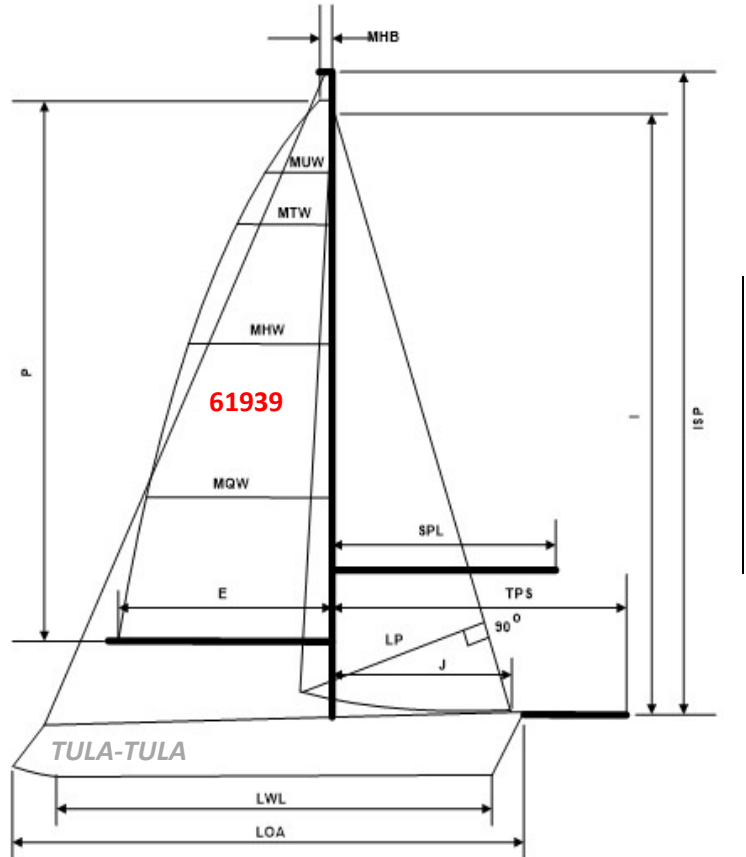

## HANDICAP ADJUSTMENTS

*Adjustments must be requested by the owner and are only made based on visual inspection and/or physical measurement by an authorized PHRF-SS measurer.*

Owner Signature: \_\_\_\_\_

*My signature attests to the fact that all the information contained on this certificate is true and correct to the best of my knowledge and that I have not made any modifications to the boat which have not been reported to PHRF-SS.*

**Certificate Issue: 3/1/2026**

**Certificate Expires: 3/31/2027**



# SOUTH SHORE PHRF HANDICAP CERTIFICATE 2026

PHRF-SS, LLC., PO Box 347021, Cleveland, OH 44134

<http://phrfss.org>

**HCP (Spinnaker):** 168 sec/nm  
**NSP (Non-Spinnaker):** 176 sec/nm  
**PPF (Perf Prediction Factor):** 14.73  
**TCF (Time Correction Factor):** 0.9407  
**CRWT (Crew Weight Limit):** 1852 LBS.

**YACHT NAME:** SNIPPERDOG  
**DESIGN:** CAT 320 WK  
**OWNER:** Phillip Dubiel  
**CERTIFICATE:** **STND**  
**CLASSIFICATION:** DISP  
**SAIL NO:** 365  
**POWER:** IB  
**YACHT CLUB:** EWYC

**LOA:** 33 FT.  
**LWL:** 28 FT.  
**BEAM:** 12 FT.  
**DRAFT:** 4.30 FT.  
**DISPLACEMENT:** 11700 LBS.  
**BALLAST:** 4400 LBS.  
**SAIL AREA:** 520 SQ. FT.  
**THS:** 7.09 KN.

**I:** 43.58 FT.  
**ISP:** 43.58 FT.  
**J:** 12.33 FT.  
**JSP/TPS:** 12.33 FT.  
**P:** 38.00 FT.  
**E:** 13.25 FT.

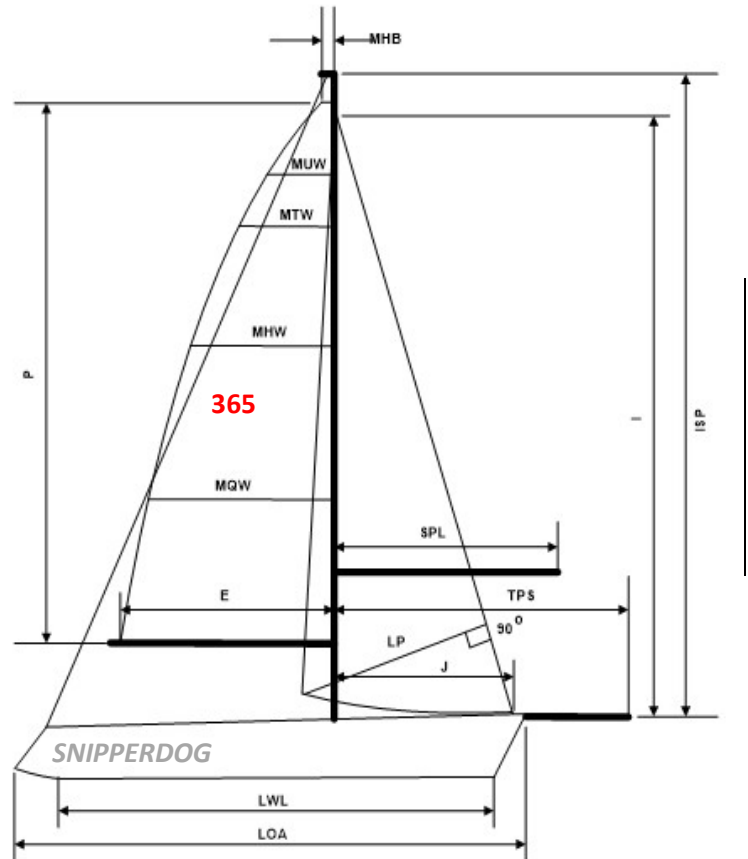

## HANDICAP ADJUSTMENTS

+3 RFG

*Adjustments must be requested by the owner and are only made based on visual inspection and/or physical measurement by an authorized PHRF-SS measurer.*

Owner Signature: \_\_\_\_\_

*My signature attests to the fact that all the information contained on this certificate is true and correct to the best of my knowledge and that I have not made any modifications to the boat which have not been reported to PHRF-SS.*

**Certificate Issue: 3/22/2026**

**Certificate Expires: 3/31/2027**



# SOUTH SHORE PHRF HANDICAP CERTIFICATE 2026

PHRF-SS, LLC., PO Box 347021, Cleveland, OH 44134

<http://phrfss.org>

**HCP (Spinnaker):** 177 sec/nm  
**NSP (Non-Spinnaker):** 187 sec/nm  
**PPF (Perf Prediction Factor):** 18.98  
**TCF (Time Correction Factor):** 0.9289  
**CRWT (Crew Weight Limit):** 1722 LBS.

**YACHT NAME:** GOBLIN  
**DESIGN:** CAT 30 TRBS  
**OWNER:** Andrew Dupuis  
**CERTIFICATE:** **STND**  
**CLASSIFICATION:** DISP  
**SAIL NO:** 4118  
**POWER:** IB  
**YACHT CLUB:** EWYC

**LOA:** 30 FT.  
**LWL:** 25 FT.  
**BEAM:** 11 FT.  
**DRAFT:** 5.25 FT.  
**DISPLACEMENT:** 10200 LBS.  
**BALLAST:** 4250 LBS.  
**SAIL AREA:** 451 SQ. FT.  
**THS:** 6.70 KN.

**I:** 41.00 FT.  
**ISP:** 41.00 FT.  
**J:** 11.50 FT.  
**JSP/TPS:** 13.15 FT.  
**P:** 37.50 FT.  
**E:** 11.50 FT.

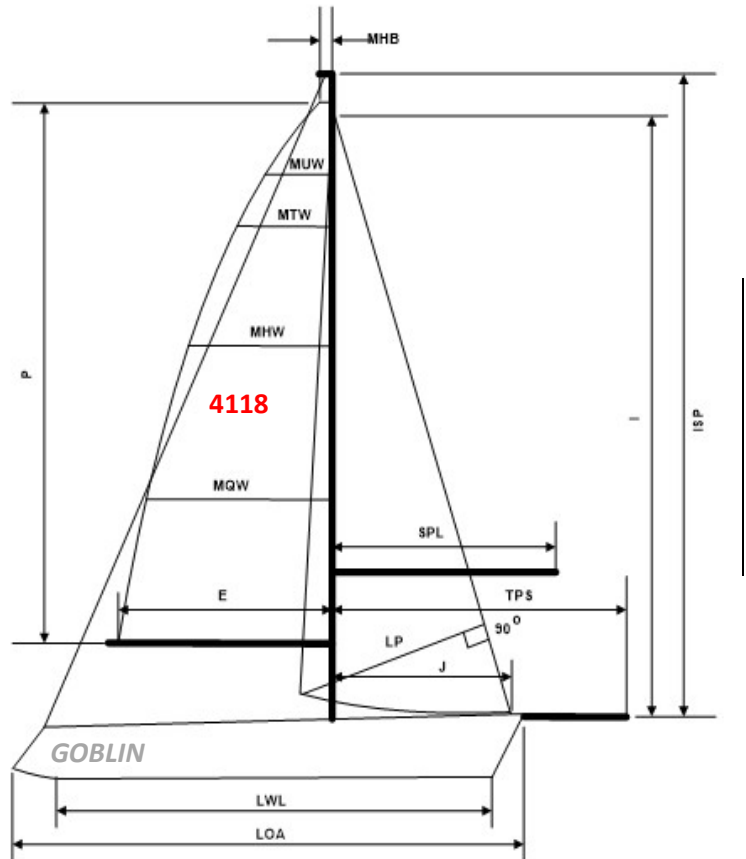

## HANDICAP ADJUSTMENTS

+3RFG

*Adjustments must be requested by the owner and are only made based on visual inspection and/or physical measurement by an authorized PHRF-SS measurer.*

Owner Signature: \_\_\_\_\_

*My signature attests to the fact that all the information contained on this certificate is true and correct to the best of my knowledge and that I have not made any modifications to the boat which have not been reported to PHRF-SS.*

**Certificate Issue: 5/27/2026**

**Certificate Expires: 3/31/2027**



# SOUTH SHORE PHRF HANDICAP CERTIFICATE 2026

PHRF-SS, LLC., PO Box 347021, Cleveland, OH 44134

<http://phrfss.org>

**HCP (Spinnaker):** 90 sec/nm  
**NSP (Non-Spinnaker):** 100 sec/nm  
**PPF (Perf Prediction Factor):** 6.77  
**TCF (Time Correction Factor):** 1.0571  
**CRWT (Crew Weight Limit):** 2061 LBS.

**YACHT NAME:** OVATION  
**DESIGN:** J-105 ODR  
**OWNER:** Tom & Cindy Einhouse  
**CERTIFICATE:** **STND**  
**CLASSIFICATION:** DISP  
**SAIL NO:** 393  
**POWER:** IB  
**YACHT CLUB:** EWYC

**LOA:** 35 FT.  
**LWL:** 30 FT.  
**BEAM:** 11 FT.  
**DRAFT:** 6.50 FT.  
**DISPLACEMENT:** 8575 LBS.  
**BALLAST:** 3400 LBS.  
**SAIL AREA:** 577 SQ. FT.  
**THS:** 7.28 KN.

**I:** 40.60 FT.  
**ISP:** 42.10 FT.  
**J:** 13.50 FT.  
**JSP/TPS:** 19.00 FT.  
**P:** 41.50 FT.  
**E:** 14.60 FT.

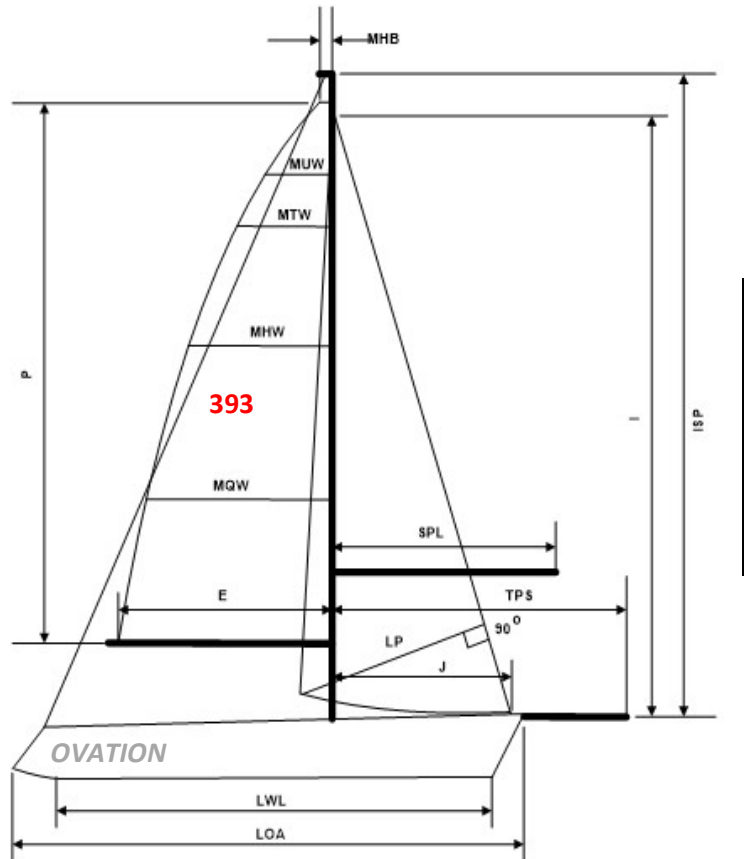

## HANDICAP ADJUSTMENTS

ODR 102% JIB/89 SQM ASYM

*Adjustments must be requested by the owner and are only made based on visual inspection and/or physical measurement by an authorized PHRF-SS measurer.*

Owner Signature: \_\_\_\_\_

*My signature attests to the fact that all the information contained on this certificate is true and correct to the best of my knowledge and that I have not made any modifications to the boat which have not been reported to PHRF-SS.*

**Certificate Issue: 3/1/2026**

**Certificate Expires: 3/31/2027**



# SOUTH SHORE PHRF HANDICAP CERTIFICATE 2026

PHRF-SS, LLC., PO Box 347021, Cleveland, OH 44134

<http://phrfss.org>

**HCP (Spinnaker):** 177 sec/nm  
**NSP (Non-Spinnaker):** 182 sec/nm  
**PPF (Perf Prediction Factor):** 10.64  
**TCF (Time Correction Factor):** 0.9289  
**CRWT (Crew Weight Limit):** 1541 LBS.

**YACHT NAME:** UPSTART  
**DESIGN:** S2 7.9 DB IB  
**OWNER:** Jack Filak  
**CERTIFICATE:** **STND**  
**CLASSIFICATION:** DISP  
**SAIL NO:** 2521  
**POWER:** IB  
**YACHT CLUB:** EWYC

**LOA:** 26 FT.  
**LWL:** 22 FT.  
**BEAM:** 9 FT.  
**DRAFT:** 5.00 FT.  
**DISPLACEMENT:** 4577 LBS.  
**BALLAST:** 1550 LBS.  
**SAIL AREA:** 325 SQ. FT.  
**THS:** 6.24 KN.

**I:** 30.50 FT.  
**ISP:** 30.50 FT.  
**J:** 9.50 FT.  
**JSP/TPS:** 9.50 FT.  
**P:** 29.42 FT.  
**E:** 12.25 FT.

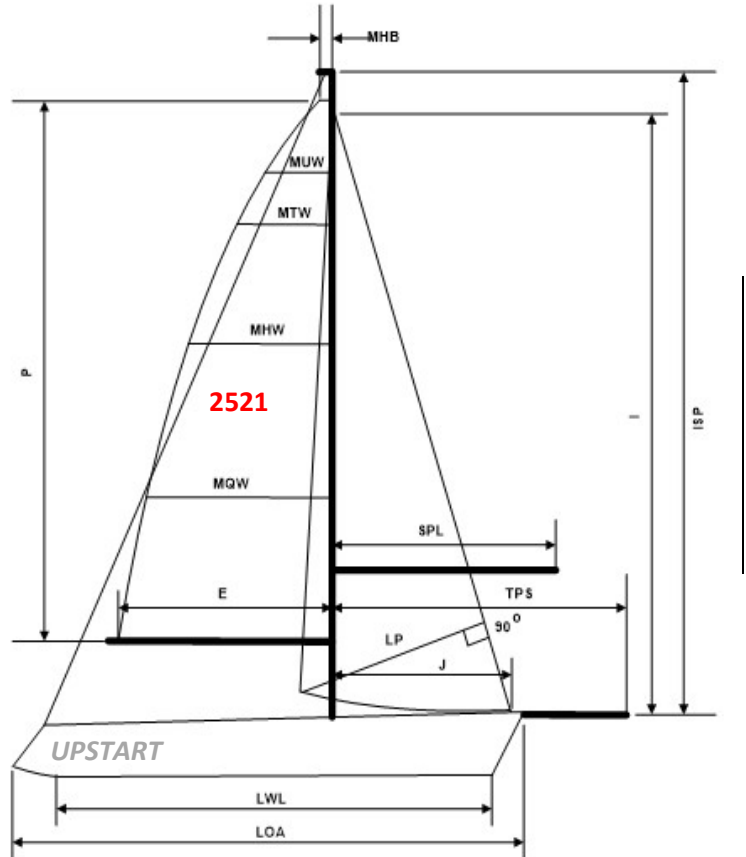

## HANDICAP ADJUSTMENTS

*Adjustments must be requested by the owner and are only made based on visual inspection and/or physical measurement by an authorized PHRF-SS measurer.*

Owner Signature: \_\_\_\_\_

*My signature attests to the fact that all the information contained on this certificate is true and correct to the best of my knowledge and that I have not made any modifications to the boat which have not been reported to PHRF-SS.*

**Certificate Issue: 3/5/2026**

**Certificate Expires: 3/31/2027**



# SOUTH SHORE PHRF HANDICAP CERTIFICATE 2026

PHRF-SS, LLC., PO Box 347021, Cleveland, OH 44134

<http://phrfss.org>

**HCP (Spinnaker):** 66 sec/nm  
**NSP (Non-Spinnaker):** 75 sec/nm  
**PPF (Perf Prediction Factor):** 6.08  
**TCF (Time Correction Factor):** 1.0990  
**CRWT (Crew Weight Limit):** 2289 LBS.

**YACHT NAME:** BREEZIN'  
**DESIGN:** C&C 115 SPRIT  
**OWNER:** Rich Galaska  
**CERTIFICATE:** **STND**  
**CLASSIFICATION:** DISP  
**SAIL NO:** 11555  
**POWER:** IB  
**YACHT CLUB:** FCYC

**LOA:** 38 FT.  
**LWL:** 33 FT.  
**BEAM:** 12 FT.  
**DRAFT:** 6.67 FT.  
**DISPLACEMENT:** 11800 LBS.  
**BALLAST:** 4200 LBS.  
**SAIL AREA:** 781 SQ. FT.  
**THS:** 7.70 KN.

**I:** 52.16 FT.  
**ISP:** 52.16 FT.  
**J:** 14.50 FT.  
**JSP/TPS:** 19.00 FT.  
**P:** 49.33 FT.  
**E:** 16.33 FT.

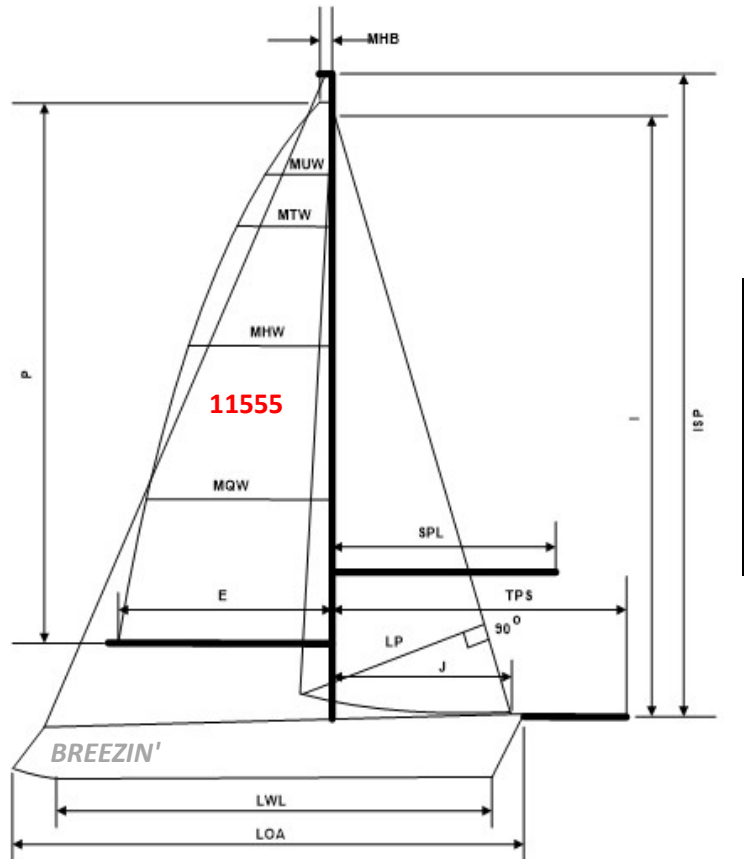

## HANDICAP ADJUSTMENTS

Adjustments must be requested by the owner and are only made based on visual inspection and/or physical measurement by an authorized PHRF-SS measurer.

Owner Signature: \_\_\_\_\_

*My signature attests to the fact that all the information contained on this certificate is true and correct to the best of my knowledge and that I have not made any modifications to the boat which have not been reported to PHRF-SS.*

**Certificate Issue: 4/4/2026**

**Certificate Expires: 3/31/2027**



# SOUTH SHORE PHRF HANDICAP CERTIFICATE 2026

PHRF-SS, LLC., PO Box 347021, Cleveland, OH 44134

<http://phrfss.org>

**HCP (Spinnaker):** 171 sec/nm  
**NSP (Non-Spinnaker):** 180 sec/nm  
**PPF (Perf Prediction Factor):** 14.17  
**TCF (Time Correction Factor):** 0.9367  
**CRWT (Crew Weight Limit):** 1840 LBS.

**YACHT NAME:** VERKTADUE  
**DESIGN:** IRWIN 32 CITATION SHLW  
**OWNER:** Jeff Geisinger  
**CERTIFICATE:** **STND**  
**CLASSIFICATION:** DISP  
**SAIL NO:** 321  
**POWER:** IB  
**YACHT CLUB:** EWYC

**LOA:** 32 FT.  
**LWL:** 27 FT.  
**BEAM:** 11 FT.  
**DRAFT:** 4.00 FT.  
**DISPLACEMENT:** 10500 LBS.  
**BALLAST:** 4600 LBS.  
**SAIL AREA:** 518 SQ. FT.  
**THS:** 6.93 KN.

**I:** 43.00 FT.  
**ISP:** 43.00 FT.  
**J:** 13.20 FT.  
**JSP/TPS:** 13.20 FT.  
**P:** 37.50 FT.  
**E:** 12.50 FT.

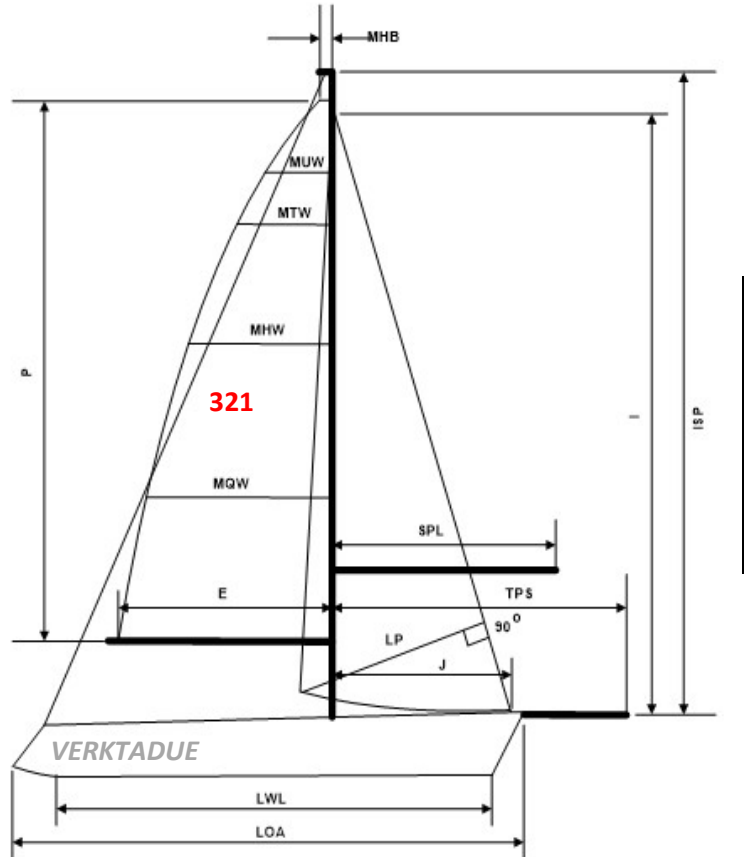

## HANDICAP ADJUSTMENTS

+3 RFG

*Adjustments must be requested by the owner and are only made based on visual inspection and/or physical measurement by an authorized PHRF-SS measurer.*

Owner Signature: \_\_\_\_\_

*My signature attests to the fact that all the information contained on this certificate is true and correct to the best of my knowledge and that I have not made any modifications to the boat which have not been reported to PHRF-SS.*

**Certificate Issue: 2/26/2026**

**Certificate Expires: 3/31/2027**



# SOUTH SHORE PHRF HANDICAP CERTIFICATE 2026

PHRF-SS, LLC., PO Box 347021, Cleveland, OH 44134

<http://phrfss.org>

**HCP (Spinnaker):** 153 sec/nm  
**NSP (Non-Spinnaker):** 157 sec/nm  
**PPF (Perf Prediction Factor):** 11.59  
**TCF (Time Correction Factor):** 0.9610  
**CRWT (Crew Weight Limit):** 1989 LBS.

**YACHT NAME:** TIGGER  
**DESIGN:** FIRST (BENET) 32s5 WK  
**OWNER:** Paul Harrison  
**CERTIFICATE:** **STND**  
**CLASSIFICATION:** DISP  
**SAIL NO:** 72  
**POWER:** IB  
**YACHT CLUB:** FCYC

**LOA:** 35 FT.  
**LWL:** 29 FT.  
**BEAM:** 12 FT.  
**DRAFT:** 6.00 FT.  
**DISPLACEMENT:** 11460 LBS.  
**BALLAST:** 4190 LBS.  
**SAIL AREA:** 554 SQ. FT.  
**THS:** 7.26 KN.

**I:** 41.66 FT.  
**ISP:** 41.66 FT.  
**J:** 11.15 FT.  
**JSP/TPS:** 11.15 FT.  
**P:** 42.65 FT.  
**E:** 15.09 FT.

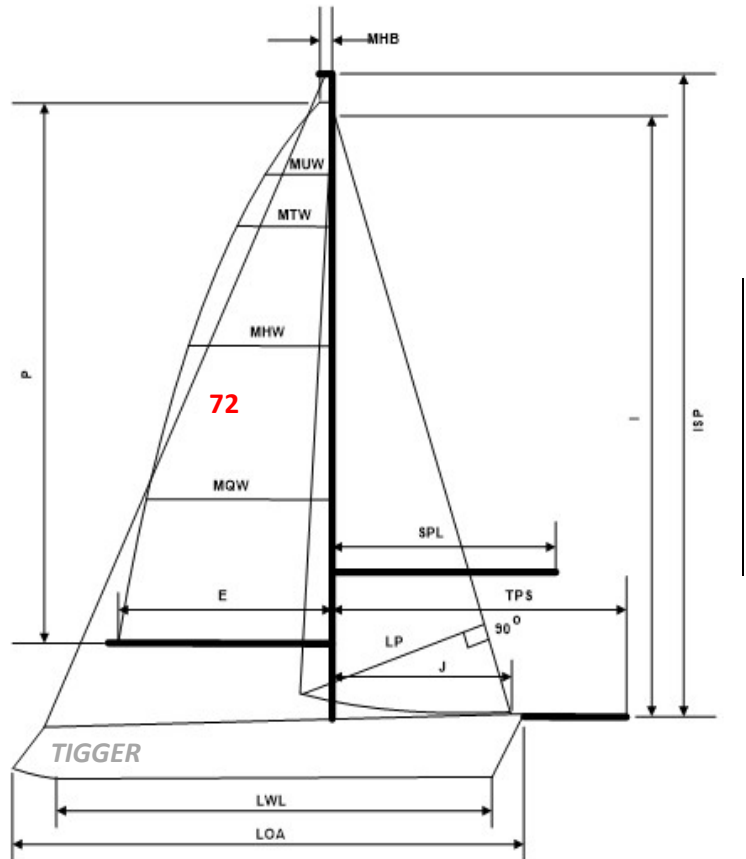

## HANDICAP ADJUSTMENTS

+3 RFG

Adjustments must be requested by the owner and are only made based on visual inspection and/or physical measurement by an authorized PHRF-SS measurer.

Owner Signature: \_\_\_\_\_

*My signature attests to the fact that all the information contained on this certificate is true and correct to the best of my knowledge and that I have not made any modifications to the boat which have not been reported to PHRF-SS.*

**Certificate Issue: 3/23/2026**

**Certificate Expires: 3/31/2027**



# SOUTH SHORE PHRF HANDICAP CERTIFICATE 2026

PHRF-SS, LLC., PO Box 347021, Cleveland, OH 44134

<http://phrfss.org>

**HCP (Spinnaker):** 48 sec/nm  
**NSP (Non-Spinnaker):** 56 sec/nm  
**PPF (Perf Prediction Factor):** 7.22  
**TCF (Time Correction Factor):** 1.1327  
**CRWT (Crew Weight Limit):** 2380 LBS.

**YACHT NAME:** CommoHAWK  
**DESIGN:** J-39  
**OWNER:** Conor Hawkins  
**CERTIFICATE:** **STND**  
**CLASSIFICATION:** DISP  
**SAIL NO:** 43511  
**POWER:** IB  
**YACHT CLUB:** EWYC

**LOA:** 39.42 FT.  
**LWL:** 32.50 FT.  
**BEAM:** 12.42 FT.  
**DRAFT:** 7.25 FT.  
**DISPLACEMENT:** 12900 LBS.  
**BALLAST:** 5900 LBS.  
**SAIL AREA:** 799 SQ. FT.  
**THS:** 7.64 KN.

**I:** 53.50 FT.  
**ISP:** 53.50 FT.  
**J:** 15.50 FT.  
**JSP/TPS:** 15.50 FT.  
**P:** 47.20 FT.  
**E:** 16.30 FT.

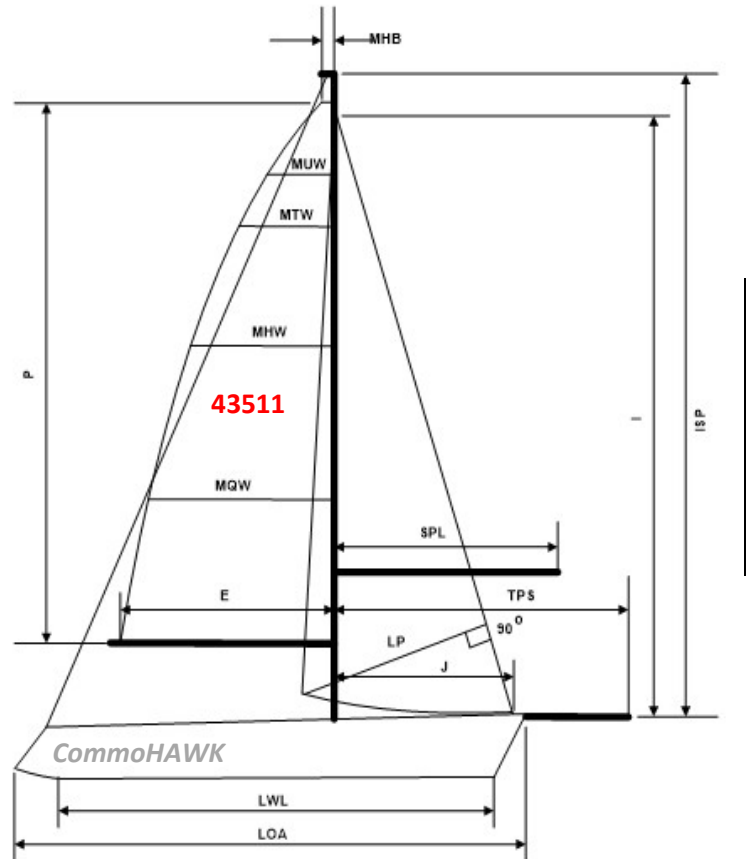

## HANDICAP ADJUSTMENTS

*Adjustments must be requested by the owner and are only made based on visual inspection and/or physical measurement by an authorized PHRF-SS measurer.*

Owner Signature: \_\_\_\_\_

*My signature attests to the fact that all the information contained on this certificate is true and correct to the best of my knowledge and that I have not made any modifications to the boat which have not been reported to PHRF-SS.*

**Certificate Issue: 3/5/2026**

**Certificate Expires: 3/31/2027**



# SOUTH SHORE PHRF HANDICAP CERTIFICATE 2026

PHRF-SS, LLC., PO Box 347021, Cleveland, OH 44134

<http://phrfss.org>

**HCP (Spinnaker):** 75 sec/nm  
**NSP (Non-Spinnaker):** 83 sec/nm  
**PPF (Perf Prediction Factor):** 9.10  
**TCF (Time Correction Factor):** 1.0829  
**CRWT (Crew Weight Limit):** 2133 LBS.

**YACHT NAME:** GLASS PONY  
**DESIGN:** FIRST (BENET) 35-2  
**OWNER:** Jason Huffman  
**CERTIFICATE:** **STND**  
**CLASSIFICATION:** DISP  
**SAIL NO:** 25649  
**POWER:** IB  
**YACHT CLUB:** SSC

**LOA:** 35 FT.  
**LWL:** 31 FT.  
**BEAM:** 12 FT.  
**DRAFT:** 7.19 FT.  
**DISPLACEMENT:** 11909 LBS.  
**BALLAST:** 3682 LBS.  
**SAIL AREA:** 664 SQ. FT.  
**THS:** 7.41 KN.

**I:** 46.82 FT.  
**ISP:** 52.14 FT.  
**J:** 12.93 FT.  
**JSP/TPS:** 15.93 FT.  
**P:** 45.87 FT.  
**E:** 15.75 FT.

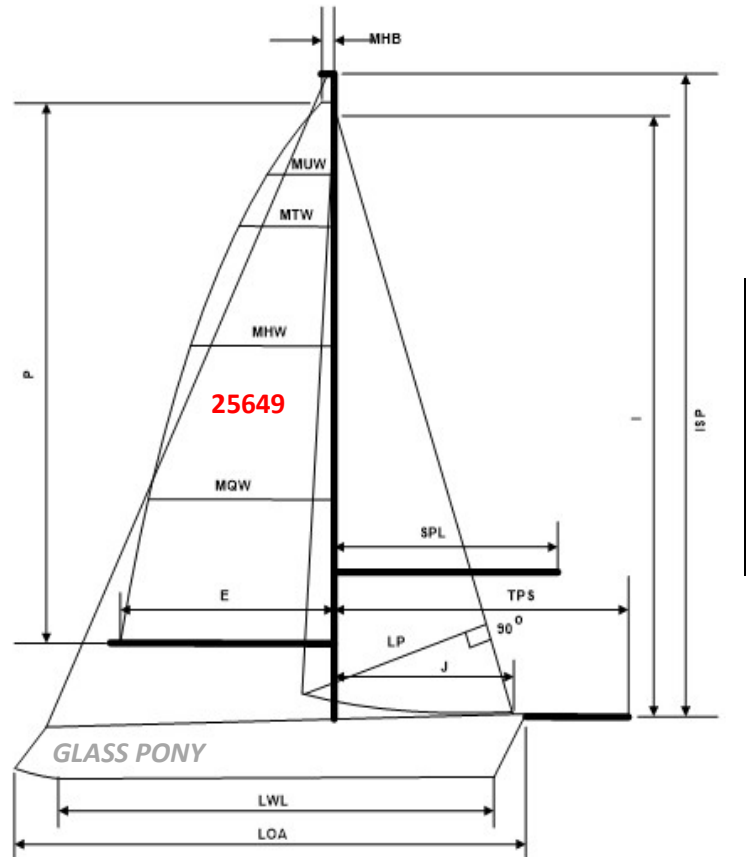

## HANDICAP ADJUSTMENTS

Using sym and asym; 3ft sprit added

*Adjustments must be requested by the owner and are only made based on visual inspection and/or physical measurement by an authorized PHRF-SS measurer.*

Owner Signature: \_\_\_\_\_

*My signature attests to the fact that all the information contained on this certificate is true and correct to the best of my knowledge and that I have not made any modifications to the boat which have not been reported to PHRF-SS.*

**Certificate Issue: 3/5/2026**

**Certificate Expires: 3/31/2027**



# SOUTH SHORE PHRF HANDICAP CERTIFICATE 2026

PHRF-SS, LLC., PO Box 347021, Cleveland, OH 44134

<http://phrfss.org>

**HCP (Spinnaker):** 84 sec/nm  
**NSP (Non-Spinnaker):** 95 sec/nm  
**PPF (Perf Prediction Factor):** 4.79  
**TCF (Time Correction Factor):** 1.0673  
**CRWT (Crew Weight Limit):** 1835 LBS.

**YACHT NAME:** BANTAM  
**DESIGN:** J-88 ODR  
**OWNER:** Brian Lake  
**CERTIFICATE:** **STND**  
**CLASSIFICATION:** DISP  
**SAIL NO:** 30  
**POWER:** IB  
**YACHT CLUB:** MHYC

**LOA:** 29.19 FT.  
**LWL:** 26.84 FT.  
**BEAM:** 9.50 FT.  
**DRAFT:** 6.50 FT.  
**DISPLACEMENT:** 4990 LBS.  
**BALLAST:** 1840 LBS.  
**SAIL AREA:** 439 SQ. FT.  
**THS:** 6.94 KN.

**I:** 38.67 FT.  
**ISP:** 41.80 FT.  
**J:** 11.28 FT.  
**JSP/TPS:** 18.05 FT.  
**P:** 36.82 FT.  
**E:** 12.00 FT.

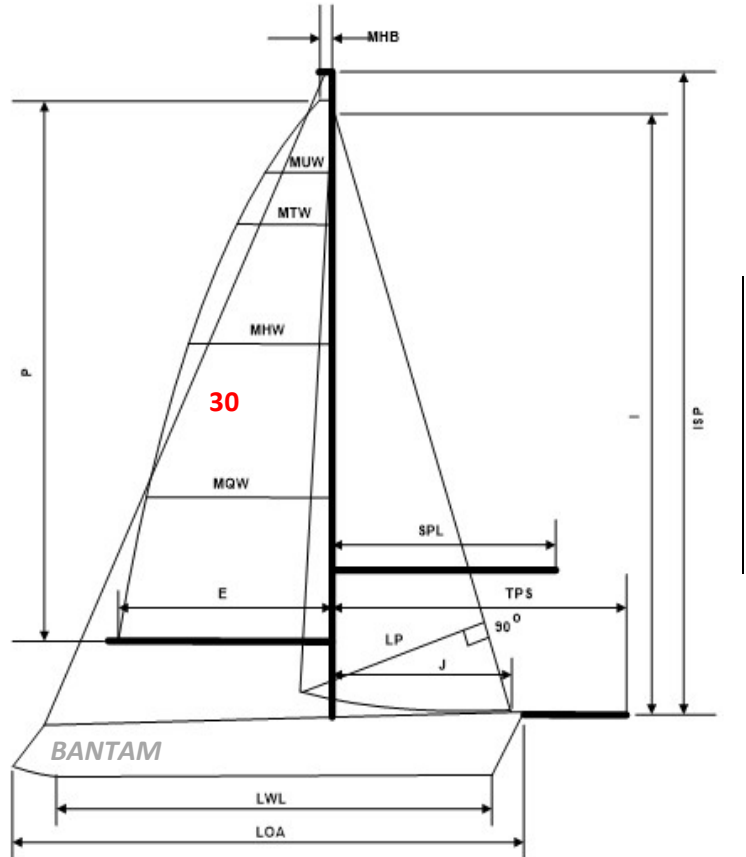

## HANDICAP ADJUSTMENTS

*Adjustments must be requested by the owner and are only made based on visual inspection and/or physical measurement by an authorized PHRF-SS measurer.*

Owner Signature: \_\_\_\_\_

*My signature attests to the fact that all the information contained on this certificate is true and correct to the best of my knowledge and that I have not made any modifications to the boat which have not been reported to PHRF-SS.*

**Certificate Issue: 4/15/2026**

**Certificate Expires: 3/31/2027**



# SOUTH SHORE PHRF HANDICAP CERTIFICATE 2026

PHRF-SS, LLC., PO Box 347021, Cleveland, OH 44134

<http://phrfss.org>

**HCP (Spinnaker):** 228 sec/nm  
**NSP (Non-Spinnaker):** 235 sec/nm  
**PPF (Perf Prediction Factor):** 7.51  
**TCF (Time Correction Factor):** 0.8672  
**CRWT (Crew Weight Limit):** 1335 LBS.

**YACHT NAME:** SISU  
**DESIGN:** SANTANA 2023 A TM  
**OWNER:** Jeff Lehtinen  
**CERTIFICATE:** **STND**  
**CLASSIFICATION:** DISP  
**SAIL NO:** 2023  
**POWER:** IB  
**YACHT CLUB:** GRSC

**LOA:** 23 FT.  
**LWL:** 21 FT.  
**BEAM:** 9 FT.  
**DRAFT:** 5.33 FT.  
**DISPLACEMENT:** 2880 LBS.  
**BALLAST:** 1300 LBS.  
**SAIL AREA:** 247 SQ. FT.  
**THS:** 6.08 KN.

**I:** 25.41 FT.  
**ISP:** 30.00 FT.  
**J:** 8.75 FT.  
**JSP/TPS:** 8.75 FT.  
**P:** 27.17 FT.  
**E:** 10.00 FT.

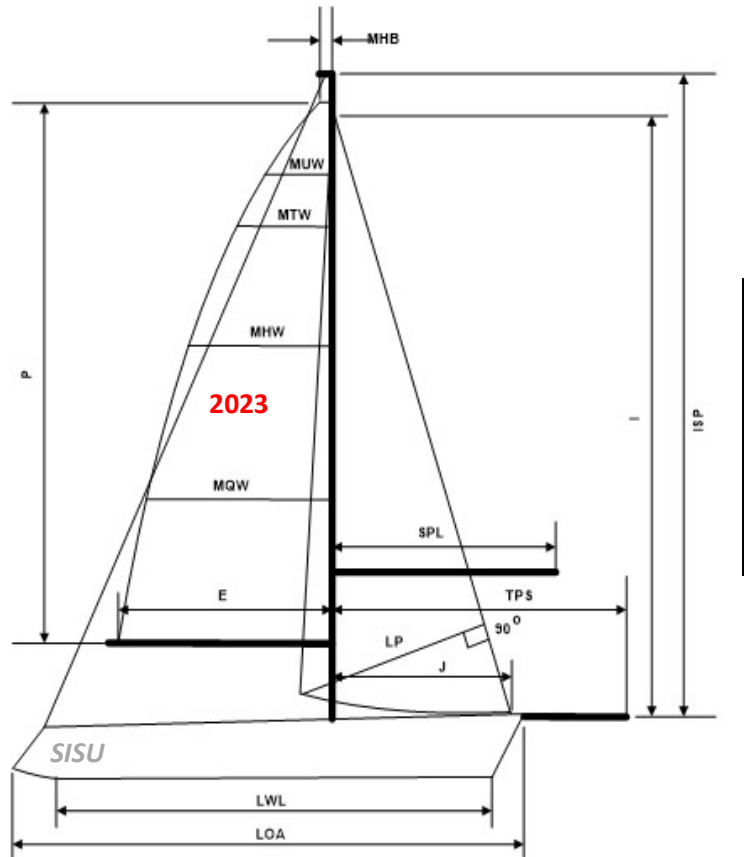

## HANDICAP ADJUSTMENTS

Water ballast must be kept on-board

*Adjustments must be requested by the owner and are only made based on visual inspection and/or physical measurement by an authorized PHRF-SS measurer.*

Owner Signature: \_\_\_\_\_

*My signature attests to the fact that all the information contained on this certificate is true and correct to the best of my knowledge and that I have not made any modifications to the boat which have not been reported to PHRF-SS.*

**Certificate Issue: 4/6/2026**

**Certificate Expires: 3/31/2027**



# SOUTH SHORE PHRF HANDICAP CERTIFICATE 2026

PHRF-SS, LLC., PO Box 347021, Cleveland, OH 44134

<http://phrfss.org>

**HCP (Spinnaker):** 69 sec/nm  
**NSP (Non-Spinnaker):** 79 sec/nm  
**PPF (Perf Prediction Factor):** 6.29  
**TCF (Time Correction Factor):** 1.0936  
**CRWT (Crew Weight Limit):** 2172 LBS.

**YACHT NAME:** WAVELENGTH  
**DESIGN:** THOMAS 35  
**OWNER:** Al Linne  
**CERTIFICATE:** **STND**  
**CLASSIFICATION:** DISP  
**SAIL NO:** 60812  
**POWER:** IB  
**YACHT CLUB:** EWYC

**LOA:** 35 FT.  
**LWL:** 31 FT.  
**BEAM:** 12 FT.  
**DRAFT:** 6.83 FT.  
**DISPLACEMENT:** 9800 LBS.  
**BALLAST:** 4450 LBS.  
**SAIL AREA:** 702 SQ. FT.  
**THS:** 7.40 KN.

**I:** 48.00 FT.  
**ISP:** 48.00 FT.  
**J:** 14.25 FT.  
**JSP/TPS:** 18.75 FT.  
**P:** 48.00 FT.  
**E:** 15.00 FT.

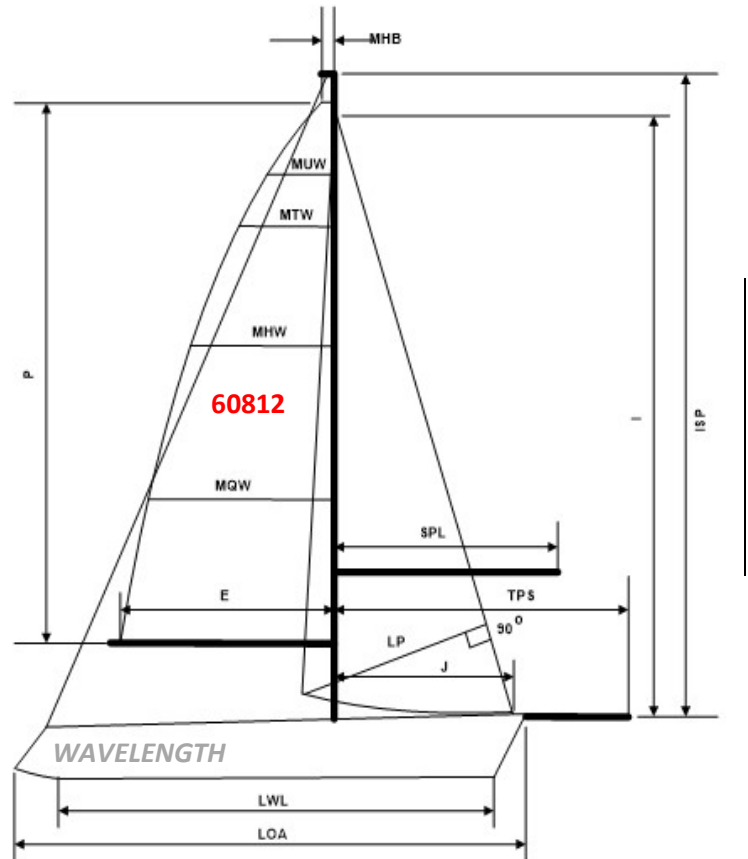

## HANDICAP ADJUSTMENTS

-3CM / 129% A-2 ASYM FRAC

*Adjustments must be requested by the owner and are only made based on visual inspection and/or physical measurement by an authorized PHRF-SS measurer.*

Owner Signature: \_\_\_\_\_

*My signature attests to the fact that all the information contained on this certificate is true and correct to the best of my knowledge and that I have not made any modifications to the boat which have not been reported to PHRF-SS.*

**Certificate Issue: 3/1/2026**

**Certificate Expires: 3/31/2027**



# SOUTH SHORE PHRF HANDICAP CERTIFICATE 2026

PHRF-SS, LLC., PO Box 347021, Cleveland, OH 44134

<http://phrfss.org>

**HCP (Spinnaker):** 172 sec/nm  
**NSP (Non-Spinnaker):** 180 sec/nm  
**PPF (Perf Prediction Factor):** 14.73  
**TCF (Time Correction Factor):** 0.9354  
**CRWT (Crew Weight Limit):** 1845 LBS.

**YACHT NAME:** LONGSHOT  
**DESIGN:** CAT 320 WK  
**OWNER:** David Long  
**CERTIFICATE:** STND  
**CLASSIFICATION:** DISP  
**SAIL NO:** 44  
**POWER:** IB  
**YACHT CLUB:** FCYC

**LOA:** 32.50 FT.  
**LWL:** 28.00 FT.  
**BEAM:** 11.75 FT.  
**DRAFT:** 4.30 FT.  
**DISPLACEMENT:** 11700 LBS.  
**BALLAST:** 4400 LBS.  
**SAIL AREA:** 520 SQ. FT.  
**THS:** 7.09 KN.

**I:** 43.58 FT.  
**ISP:** 43.58 FT.  
**J:** 12.33 FT.  
**JSP/TPS:** 12.33 FT.  
**P:** 38.00 FT.  
**E:** 13.25 FT.

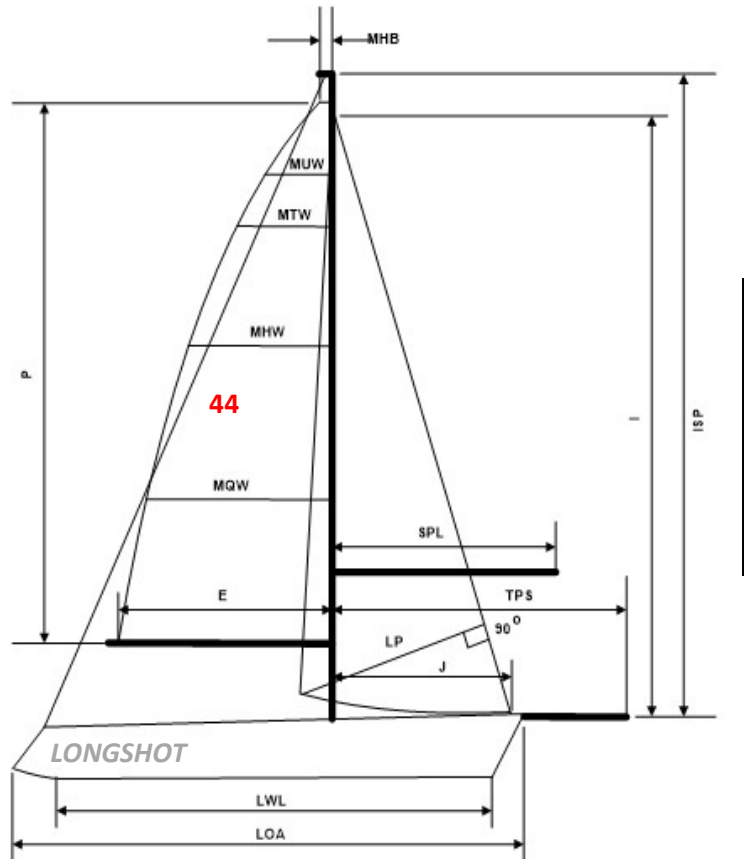

## HANDICAP ADJUSTMENTS

+3(2BX); +6RFG

*Adjustments must be requested by the owner and are only made based on visual inspection and/or physical measurement by an authorized PHRF-SS measurer.*

Owner Signature: \_\_\_\_\_

*My signature attests to the fact that all the information contained on this certificate is true and correct to the best of my knowledge and that I have not made any modifications to the boat which have not been reported to PHRF-SS.*

**Certificate Issue: 5/11/2026**

**Certificate Expires: 3/31/2027**



# SOUTH SHORE PHRF HANDICAP CERTIFICATE 2026

PHRF-SS, LLC., PO Box 347021, Cleveland, OH 44134

<http://phrfss.org>

**HCP (Spinnaker):** 105 sec/nm  
**NSP (Non-Spinnaker):** 115 sec/nm  
**PPF (Perf Prediction Factor):** 10.74  
**TCF (Time Correction Factor):** 1.0326  
**CRWT (Crew Weight Limit):** 1907 LBS.

**YACHT NAME:** MOKO JUMBIE  
**DESIGN:** J-97e  
**OWNER:** Jim Mackey  
**CERTIFICATE:** **STND**  
**CLASSIFICATION:** DISP  
**SAIL NO:** 74  
**POWER:** IB  
**YACHT CLUB:** EWYC

**LOA:** 32 FT.  
**LWL:** 27 FT.  
**BEAM:** 11 FT.  
**DRAFT:** 6.30 FT.  
**DISPLACEMENT:** 8600 LBS.  
**BALLAST:** 2900 LBS.  
**SAIL AREA:** 498 SQ. FT.  
**THS:** 6.91 KN.

**I:** 41.25 FT.  
**ISP:** 45.00 FT.  
**J:** 11.71 FT.  
**JSP/TPS:** 16.64 FT.  
**P:** 39.50 FT.  
**E:** 13.00 FT.

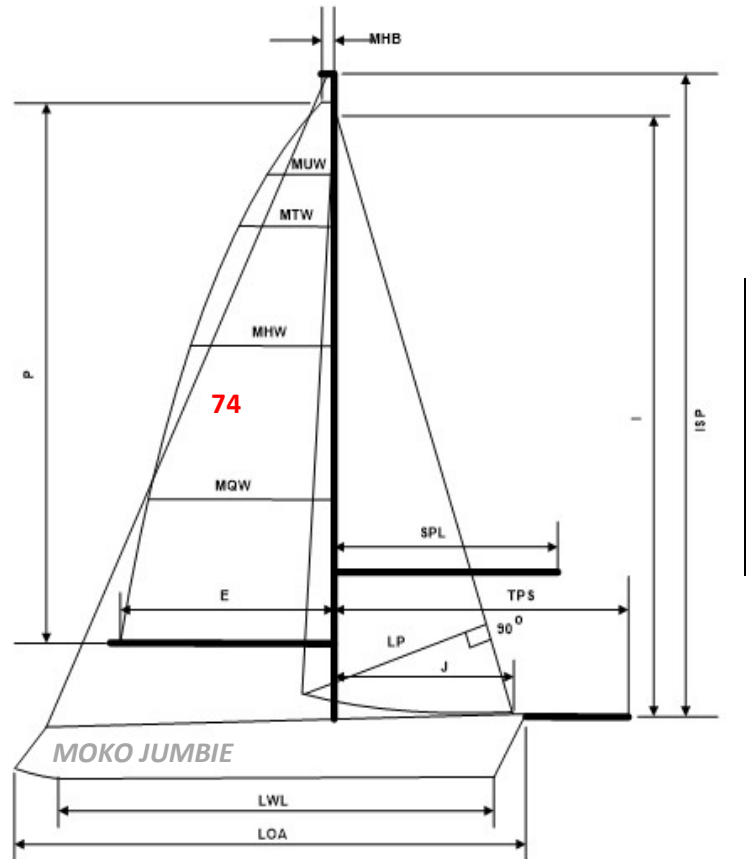

## HANDICAP ADJUSTMENTS

+3 RFG/J1/J3/J4/A1.5/A3(declared)

*Adjustments must be requested by the owner and are only made based on visual inspection and/or physical measurement by an authorized PHRF-SS measurer.*

Owner Signature: \_\_\_\_\_

*My signature attests to the fact that all the information contained on this certificate is true and correct to the best of my knowledge and that I have not made any modifications to the boat which have not been reported to PHRF-SS.*

**Certificate Issue: 5/13/2026**

**Certificate Expires: 3/31/2027**



# SOUTH SHORE PHRF HANDICAP CERTIFICATE 2026

PHRF-SS, LLC., PO Box 347021, Cleveland, OH 44134

<http://phrfss.org>

**HCP (Spinnaker):** 90 sec/nm  
**NSP (Non-Spinnaker):** 100 sec/nm  
**PPF (Perf Prediction Factor):** 6.77  
**TCF (Time Correction Factor):** 1.0571  
**CRWT (Crew Weight Limit):** 2061 LBS.

**YACHT NAME:** UNBRIDLED  
**DESIGN:** J-105 ODR  
**OWNER:** Rob Mock  
**CERTIFICATE:** **STND**  
**CLASSIFICATION:** DISP  
**SAIL NO:** 261  
**POWER:** IB  
**YACHT CLUB:** EWYC

**LOA:** 35 FT.  
**LWL:** 30 FT.  
**BEAM:** 11 FT.  
**DRAFT:** 6.50 FT.  
**DISPLACEMENT:** 8575 LBS.  
**BALLAST:** 3400 LBS.  
**SAIL AREA:** 577 SQ. FT.  
**THS:** 7.28 KN.

**I:** 40.60 FT.  
**ISP:** 42.10 FT.  
**J:** 13.50 FT.  
**JSP/TPS:** 19.00 FT.  
**P:** 41.50 FT.  
**E:** 14.60 FT.

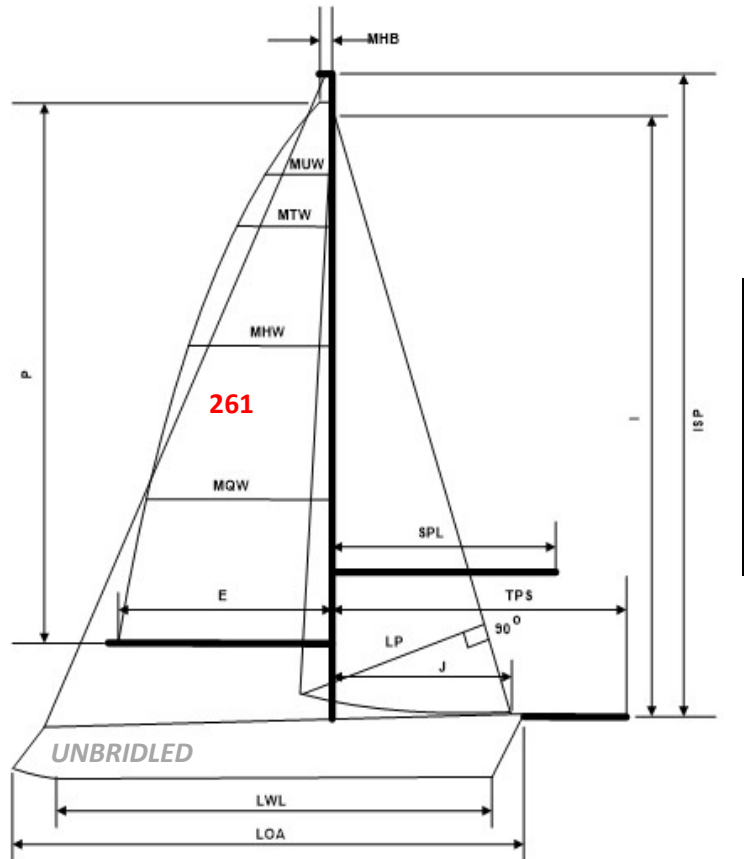

## HANDICAP ADJUSTMENTS

ODR 102% JIB/89 SQM ASYM

*Adjustments must be requested by the owner and are only made based on visual inspection and/or physical measurement by an authorized PHRF-SS measurer.*

Owner Signature: \_\_\_\_\_

*My signature attests to the fact that all the information contained on this certificate is true and correct to the best of my knowledge and that I have not made any modifications to the boat which have not been reported to PHRF-SS.*

**Certificate Issue: 3/5/2026**

**Certificate Expires: 3/31/2027**



# SOUTH SHORE PHRF HANDICAP CERTIFICATE 2026

PHRF-SS, LLC., PO Box 347021, Cleveland, OH 44134

<http://phrfss.org>

**HCP (Spinnaker):** 117 sec/nm  
**NSP (Non-Spinnaker):** 127 sec/nm  
**PPF (Perf Prediction Factor):** 7.86  
**TCF (Time Correction Factor):**  
**CRWT (Crew Weight Limit):** 1802 LBS.

**YACHT NAME:** AQUARIUS  
**DESIGN:** J-29 MH IB  
**OWNER:** Matthew Newberry  
**CERTIFICATE:** **STND**  
**CLASSIFICATION:** DISP  
**SAIL NO:** 41229  
**POWER:** IB  
**YACHT CLUB:** EWYC

**LOA:** 30 FT.  
**LWL:** 25 FT.  
**BEAM:** 11 FT.  
**DRAFT:** 5.60 FT.  
**DISPLACEMENT:** 6000 LBS.  
**BALLAST:** 2100 LBS.  
**SAIL AREA:** 450 SQ. FT.  
**THS:** 6.70 KN.

**I:** 40.00 FT.  
**ISP:** 40.00 FT.  
**J:** 12.00 FT.  
**JSP/TPS:** 14.75 FT.  
**P:** 35.00 FT.  
**E:** 12.00 FT.

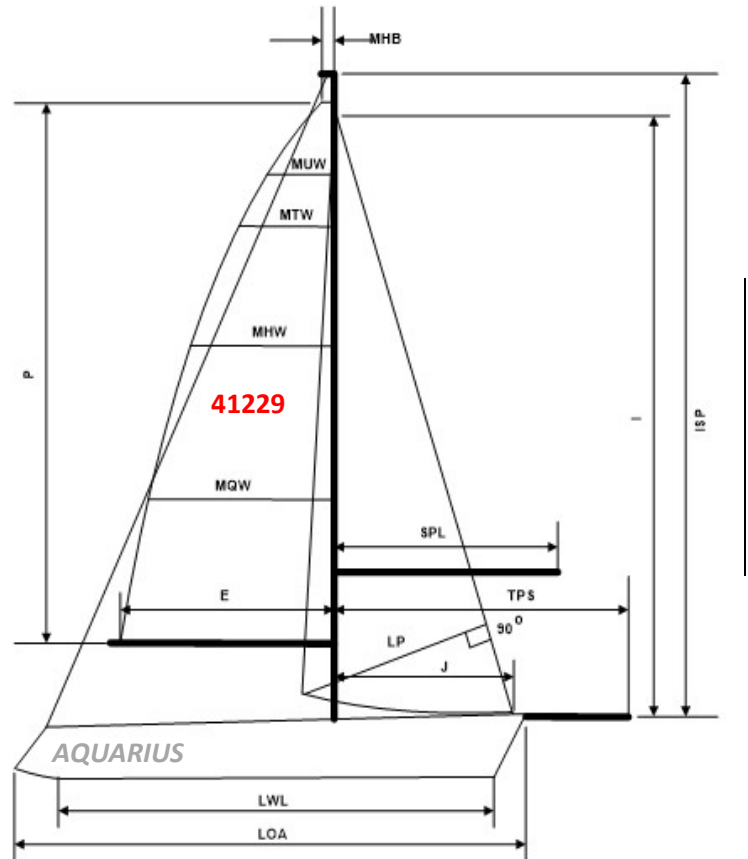

## HANDICAP ADJUSTMENTS

124% Asym Declared

*Adjustments must be requested by the owner and are only made based on visual inspection and/or physical measurement by an authorized PHRF-SS measurer.*

Owner Signature: \_\_\_\_\_

*My signature attests to the fact that all the information contained on this certificate is true and correct to the best of my knowledge and that I have not made any modifications to the boat which have not been reported to PHRF-SS.*

**Certificate Issue: 3/22/2026**

**Certificate Expires: 3/31/2027**



# SOUTH SHORE PHRF HANDICAP CERTIFICATE 2026

PHRF-SS, LLC., PO Box 347021, Cleveland, OH 44134

<http://phrfss.org>

**HCP (Spinnaker):** 135 sec/nm  
**NSP (Non-Spinnaker):** 141 sec/nm  
**PPF (Perf Prediction Factor):** 10.57  
**TCF (Time Correction Factor):** 0.9867  
**CRWT (Crew Weight Limit):** 1914 LBS.

**YACHT NAME:** EN PASSANT  
**DESIGN:** DEHLER 34  
**OWNER:** Jeffrey Posner  
**CERTIFICATE:** **STND**  
**CLASSIFICATION:** DISP  
**SAIL NO:** 85  
**POWER:** IB  
**YACHT CLUB:** ELYC

**LOA:** 33 FT.  
**LWL:** 27 FT.  
**BEAM:** 11 FT.  
**DRAFT:** 5.74 FT.  
**DISPLACEMENT:** 8818 LBS.  
**BALLAST:** 3968 LBS.  
**SAIL AREA:** 492 SQ. FT.  
**THS:** 6.99 KN.

**I:** 38.71 FT.  
**ISP:** 38.71 FT.  
**J:** 11.97 FT.  
**JSP/TPS:** 11.97 FT.  
**P:** 38.71 FT.  
**E:** 13.45 FT.

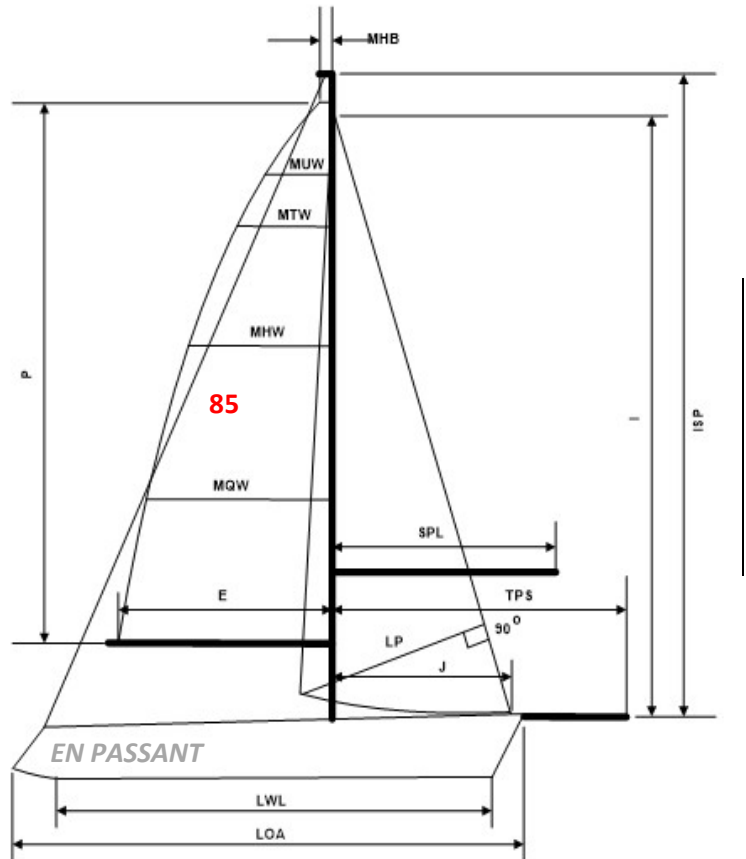

## HANDICAP ADJUSTMENTS

Adjustments must be requested by the owner and are only made based on visual inspection and/or physical measurement by an authorized PHRF-SS measurer.

Owner Signature: \_\_\_\_\_

*My signature attests to the fact that all the information contained on this certificate is true and correct to the best of my knowledge and that I have not made any modifications to the boat which have not been reported to PHRF-SS.*

**Certificate Issue: 3/1/2026**

**Certificate Expires: 3/31/2027**



# SOUTH SHORE PHRF HANDICAP CERTIFICATE 2026

PHRF-SS, LLC., PO Box 347021, Cleveland, OH 44134

<http://phrfss.org>

**HCP (Spinnaker):** 69 sec/nm  
**NSP (Non-Spinnaker):** 79 sec/nm  
**PPF (Perf Prediction Factor):** 8.18  
**TCF (Time Correction Factor):** 1.0936  
**CRWT (Crew Weight Limit):** 2143 LBS.

**YACHT NAME:** THREE SWEETS  
**DESIGN:** J-109  
**OWNER:** Anne Richman  
**CERTIFICATE:** **STND**  
**CLASSIFICATION:** DISP  
**SAIL NO:** 283  
**POWER:** IB  
**YACHT CLUB:** LYC

**LOA:** 35 FT.  
**LWL:** 31 FT.  
**BEAM:** 12 FT.  
**DRAFT:** 7.00 FT.  
**DISPLACEMENT:** 10900 LBS.  
**BALLAST:** 3900 LBS.  
**SAIL AREA:** 644 SQ. FT.  
**THS:** 7.40 KN.

**I:** 46.50 FT.  
**ISP:** 49.60 FT.  
**J:** 13.30 FT.  
**JSP/TPS:** 18.80 FT.  
**P:** 43.25 FT.  
**E:** 15.50 FT.

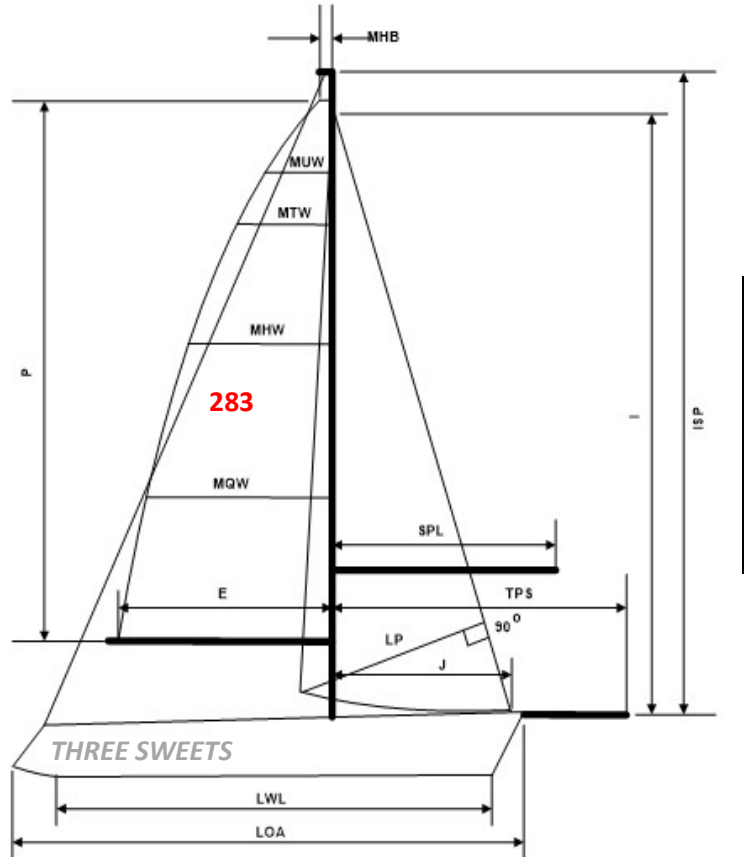

## HANDICAP ADJUSTMENTS

*Adjustments must be requested by the owner and are only made based on visual inspection and/or physical measurement by an authorized PHRF-SS measurer.*

Owner Signature: \_\_\_\_\_

*My signature attests to the fact that all the information contained on this certificate is true and correct to the best of my knowledge and that I have not made any modifications to the boat which have not been reported to PHRF-SS.*

**Certificate Issue: 5/5/2026**

**Certificate Expires: 3/31/2027**



# SOUTH SHORE PHRF HANDICAP CERTIFICATE 2026

PHRF-SS, LLC., PO Box 347021, Cleveland, OH 44134

<http://phrfss.org>

**HCP (Spinnaker):** 39 sec/nm  
**NSP (Non-Spinnaker):** 50 sec/nm  
**PPF (Perf Prediction Factor):** 5.04  
**TCF (Time Correction Factor):** 1.1503  
**CRWT (Crew Weight Limit):** 2230 LBS.

**YACHT NAME:** SPACEMAN SPIFF  
**DESIGN:** J-111  
**OWNER:** Rob Ruhlman  
**CERTIFICATE:** ODR  
**CLASSIFICATION:** HPRF  
**SAIL NO:** 134  
**POWER:** IB  
**YACHT CLUB:** LYC

**LOA:** 36 FT.  
**LWL:** 33 FT.  
**BEAM:** 11 FT.  
**DRAFT:** 7.18 FT.  
**DISPLACEMENT:** 9370 LBS.  
**BALLAST:** 3516 LBS.  
**SAIL AREA:** 659 SQ. FT.  
**THS:** 7.66 KN.

**I:** 47.74 FT.  
**ISP:** 51.23 FT.  
**J:** 13.85 FT.  
**JSP/TPS:** 21.33 FT.  
**P:** 45.24 FT.  
**E:** 14.50 FT.

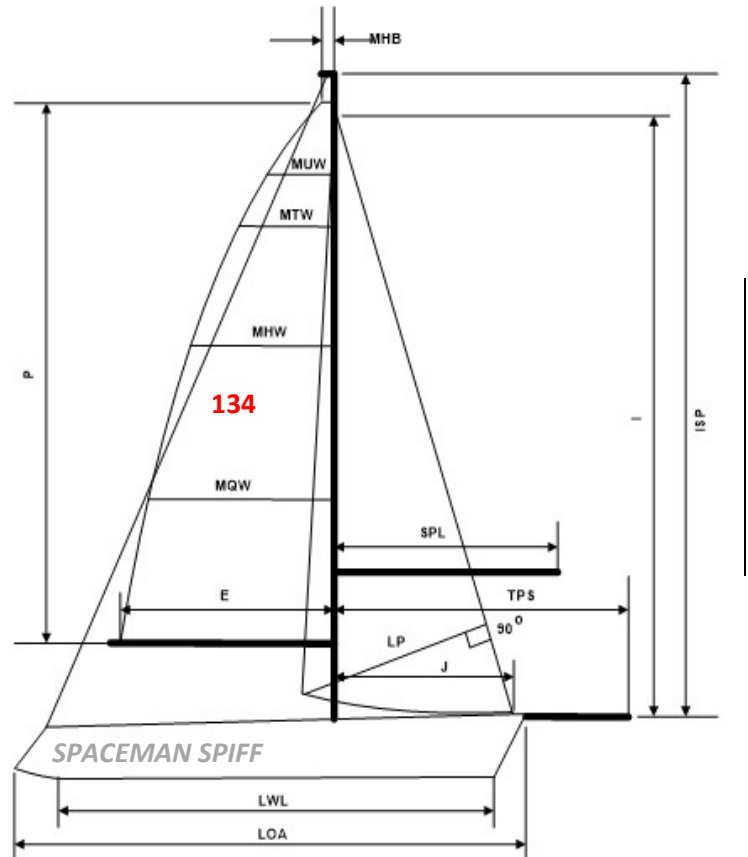

## HANDICAP ADJUSTMENTS

106% JIB, 130 SQM (1399 SQ. FT)

*Adjustments must be requested by the owner and are only made based on visual inspection and/or physical measurement by an authorized PHRF-SS measurer.*

Owner Signature: \_\_\_\_\_

*My signature attests to the fact that all the information contained on this certificate is true and correct to the best of my knowledge and that I have not made any modifications to the boat which have not been reported to PHRF-SS.*

**Certificate Issue: 3/5/2026**

**Certificate Expires: 3/31/2027**



# SOUTH SHORE PHRF HANDICAP CERTIFICATE 2026

PHRF-SS, LLC., PO Box 347021, Cleveland, OH 44134

<http://phrfss.org>

**HCP (Spinnaker):** 30 sec/nm  
**NSP (Non-Spinnaker):** 39 sec/nm  
**PPF (Perf Prediction Factor):** 5.73  
**TCF (Time Correction Factor):** 1.1684  
**CRWT (Crew Weight Limit):** 2414 LBS.

**YACHT NAME:** RUSH  
**DESIGN:** FARR 395  
**OWNER:** Laurence Rush  
**CERTIFICATE:** **STND**  
**CLASSIFICATION:** DISP  
**SAIL NO:** 39516  
**POWER:** IB  
**YACHT CLUB:** FCYC

**LOA:** 39.40 FT.  
**LWL:** 34.12 FT.  
**BEAM:** 12.16 FT.  
**DRAFT:** 7.81 FT.  
**DISPLACEMENT:** 12500 LBS.  
**BALLAST:** 4580 LBS.  
**SAIL AREA:** 826 SQ. FT.  
**THS:** 7.83 KN.

**I:** 51.25 FT.  
**ISP:** 56.89 FT.  
**J:** 14.04 FT.  
**JSP/TPS:** 20.41 FT.  
**P:** 50.45 FT.  
**E:** 18.47 FT.

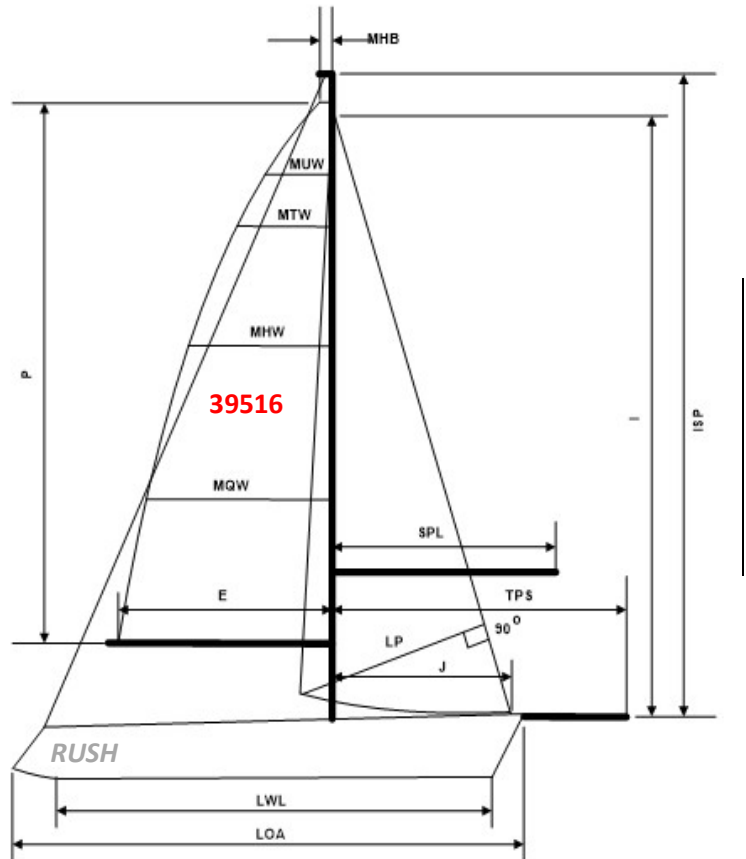

## HANDICAP ADJUSTMENTS

Rated with a Code Zero

*Adjustments must be requested by the owner and are only made based on visual inspection and/or physical measurement by an authorized PHRF-SS measurer.*

Owner Signature: \_\_\_\_\_

*My signature attests to the fact that all the information contained on this certificate is true and correct to the best of my knowledge and that I have not made any modifications to the boat which have not been reported to PHRF-SS.*

**Certificate Issue: 2/16/2026**

**Certificate Expires: 3/31/2027**



# SOUTH SHORE PHRF HANDICAP CERTIFICATE 2026

PHRF-SS, LLC., PO Box 347021, Cleveland, OH 44134

<http://phrfss.org>

**HCP (Spinnaker):** 147 sec/nm  
**NSP (Non-Spinnaker):** 157 sec/nm  
**PPF (Perf Prediction Factor):** 12.44  
**TCF (Time Correction Factor):** 0.9694  
**CRWT (Crew Weight Limit):** 1957 LBS.

**YACHT NAME:** LOTTE ROSE  
**DESIGN:** CAT 34 MK II  
**OWNER:** Bob Savinell  
**CERTIFICATE:** **STND**  
**CLASSIFICATION:** DISP  
**SAIL NO:** 1312  
**POWER:** IB  
**YACHT CLUB:** EWYC

**LOA:** 35 FT.  
**LWL:** 30 FT.  
**BEAM:** 12 FT.  
**DRAFT:** 5.58 FT.  
**DISPLACEMENT:** 11950 LBS.  
**BALLAST:** 5000 LBS.  
**SAIL AREA:** 528 SQ. FT.  
**THS:** 7.32 KN.

**I:** 44.00 FT.  
**ISP:** 44.00 FT.  
**J:** 13.50 FT.  
**JSP/TPS:** 13.50 FT.  
**P:** 38.50 FT.  
**E:** 12.00 FT.

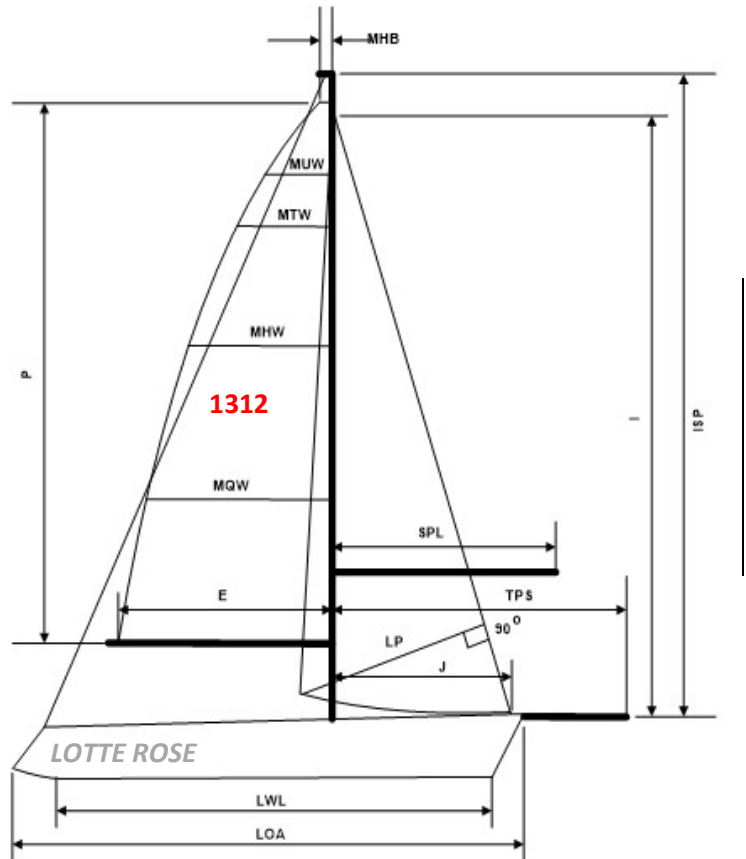

## HANDICAP ADJUSTMENTS

*Adjustments must be requested by the owner and are only made based on visual inspection and/or physical measurement by an authorized PHRF-SS measurer.*

Owner Signature: \_\_\_\_\_

*My signature attests to the fact that all the information contained on this certificate is true and correct to the best of my knowledge and that I have not made any modifications to the boat which have not been reported to PHRF-SS.*

**Certificate Issue: 3/12/2026**

**Certificate Expires: 3/31/2027**



# SOUTH SHORE PHRF HANDICAP CERTIFICATE 2026

PHRF-SS, LLC., PO Box 347021, Cleveland, OH 44134

<http://phrfss.org>

**HCP (Spinnaker):** 90 sec/nm  
**NSP (Non-Spinnaker):** 100 sec/nm  
**PPF (Perf Prediction Factor):** 6.77  
**TCF (Time Correction Factor):** 1.0571  
**CRWT (Crew Weight Limit):** 2061 LBS.

**YACHT NAME:** FALL LINE  
**DESIGN:** J-105 ODR  
**OWNER:** Chip Schaffner  
**CERTIFICATE:** STND  
**CLASSIFICATION:** DISP  
**SAIL NO:** 144  
**POWER:** IB  
**YACHT CLUB:** EWYC

**LOA:** 35 FT.  
**LWL:** 30 FT.  
**BEAM:** 11 FT.  
**DRAFT:** 6.50 FT.  
**DISPLACEMENT:** 8575 LBS.  
**BALLAST:** 3400 LBS.  
**SAIL AREA:** 577 SQ. FT.  
**THS:** 7.28 KN.

**I:** 40.60 FT.  
**ISP:** 42.10 FT.  
**J:** 13.50 FT.  
**JSP/TPS:** 19.00 FT.  
**P:** 41.50 FT.  
**E:** 14.60 FT.

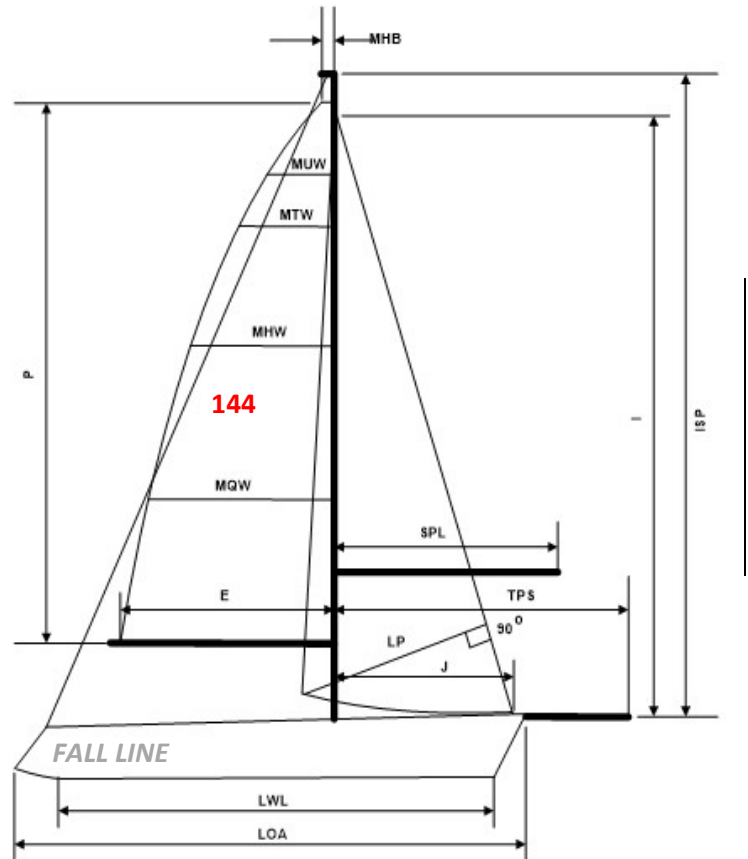

## HANDICAP ADJUSTMENTS

ODR 102% JIB/89 SQM ASYM

*Adjustments must be requested by the owner and are only made based on visual inspection and/or physical measurement by an authorized PHRF-SS measurer.*

Owner Signature: \_\_\_\_\_

*My signature attests to the fact that all the information contained on this certificate is true and correct to the best of my knowledge and that I have not made any modifications to the boat which have not been reported to PHRF-SS.*

**Certificate Issue: 3/1/2026**

**Certificate Expires: 3/31/2027**



# SOUTH SHORE PHRF HANDICAP CERTIFICATE 2026

PHRF-SS, LLC., PO Box 347021, Cleveland, OH 44134

<http://phrfss.org>

**HCP (Spinnaker):** 39 sec/nm  
**NSP (Non-Spinnaker):** 50 sec/nm  
**PPF (Perf Prediction Factor):** 5.04  
**TCF (Time Correction Factor):** 1.1503  
**CRWT (Crew Weight Limit):** 2230 LBS.

**YACHT NAME:** PAPA'S TOY  
**DESIGN:** J-111  
**OWNER:** Hugh Scott Seaholm  
**CERTIFICATE:** ODR  
**CLASSIFICATION:** HPRF  
**SAIL NO:** 93  
**POWER:** IB  
**YACHT CLUB:** MHYC

**LOA:** 36 FT.  
**LWL:** 33 FT.  
**BEAM:** 11 FT.  
**DRAFT:** 7.18 FT.  
**DISPLACEMENT:** 9370 LBS.  
**BALLAST:** 3516 LBS.  
**SAIL AREA:** 659 SQ. FT.  
**THS:** 7.66 KN.

**I:** 47.74 FT.  
**ISP:** 51.23 FT.  
**J:** 13.85 FT.  
**JSP/TPS:** 21.33 FT.  
**P:** 45.24 FT.  
**E:** 14.50 FT.

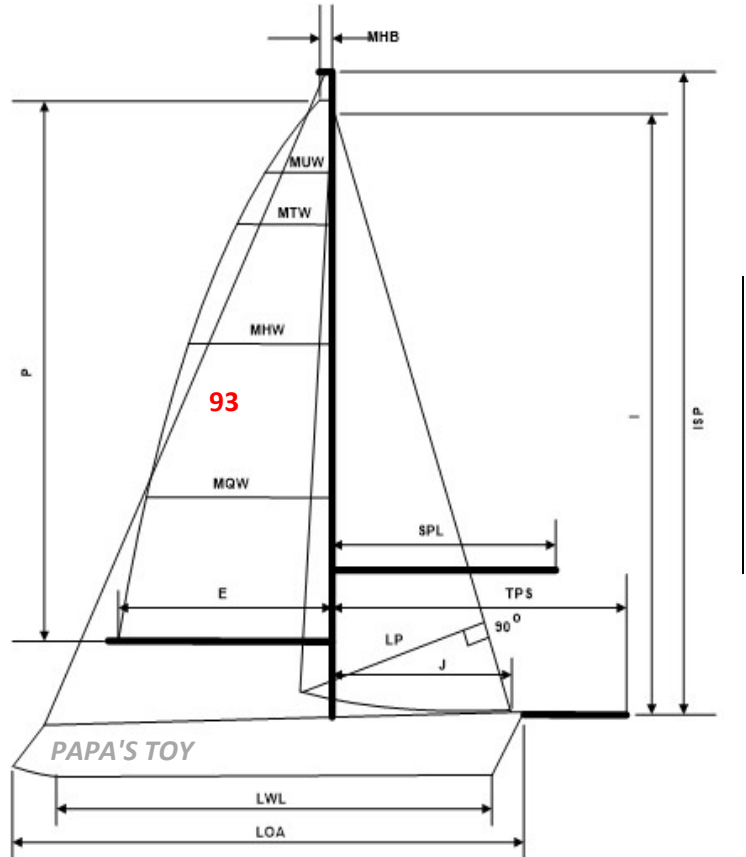

## HANDICAP ADJUSTMENTS

106% JIB, 130 SQM (1399 SQ. FT)

*Adjustments must be requested by the owner and are only made based on visual inspection and/or physical measurement by an authorized PHRF-SS measurer.*

Owner Signature: \_\_\_\_\_

*My signature attests to the fact that all the information contained on this certificate is true and correct to the best of my knowledge and that I have not made any modifications to the boat which have not been reported to PHRF-SS.*

**Certificate Issue: 2/26/2026**

**Certificate Expires: 3/31/2027**



# SOUTH SHORE PHRF HANDICAP CERTIFICATE 2026

PHRF-SS, LLC., PO Box 347021, Cleveland, OH 44134

<http://phrfss.org>

**HCP (Spinnaker):** 90 sec/nm  
**NSP (Non-Spinnaker):** 100 sec/nm  
**PPF (Perf Prediction Factor):** 6.77  
**TCF (Time Correction Factor):** 1.0571  
**CRWT (Crew Weight Limit):** 2061 LBS.

**YACHT NAME:** TRIO  
**DESIGN:** J-105 ODR  
**OWNER:** Paul Uhler  
**CERTIFICATE:** **STND**  
**CLASSIFICATION:** DISP  
**SAIL NO:** 91  
**POWER:** IB  
**YACHT CLUB:** EWYC

**LOA:** 35 FT.  
**LWL:** 30 FT.  
**BEAM:** 11 FT.  
**DRAFT:** 6.50 FT.  
**DISPLACEMENT:** 8575 LBS.  
**BALLAST:** 3400 LBS.  
**SAIL AREA:** 577 SQ. FT.  
**THS:** 7.28 KN.

**I:** 40.60 FT.  
**ISP:** 42.10 FT.  
**J:** 13.50 FT.  
**JSP/TPS:** 19.00 FT.  
**P:** 41.50 FT.  
**E:** 14.60 FT.

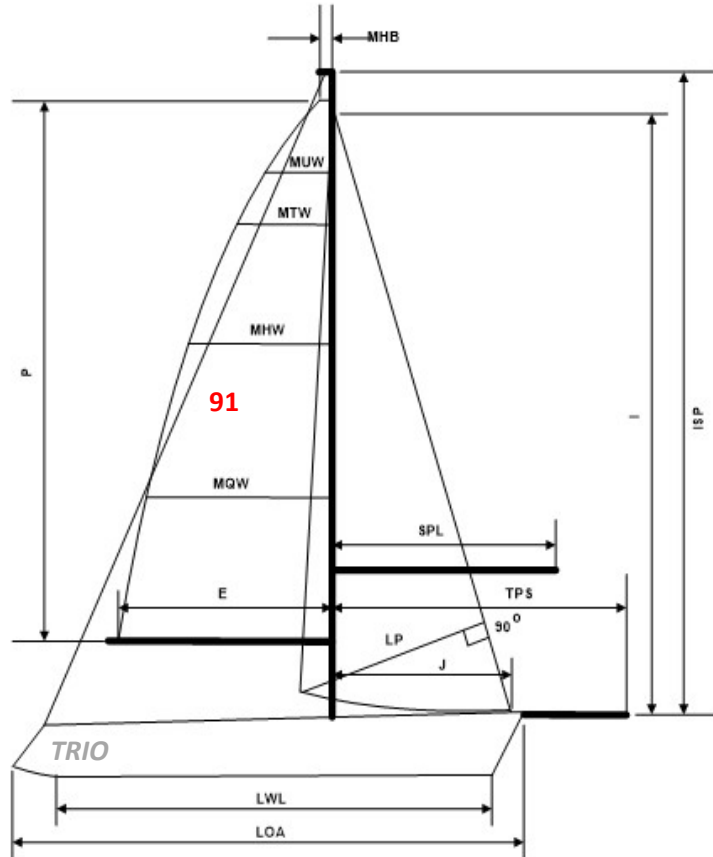

## HANDICAP ADJUSTMENTS

ODR 102% JIB/89 SQM ASYM

*Adjustments must be requested by the owner and are only made based on visual inspection and/or physical measurement by an authorized PHRF-SS measurer.*

Owner Signature: \_\_\_\_\_

*My signature attests to the fact that all the information contained on this certificate is true and correct to the best of my knowledge and that I have not made any modifications to the boat which have not been reported to PHRF-SS.*

**Certificate Issue: 3/5/2026**

**Certificate Expires: 3/31/2027**



# SOUTH SHORE PHRF HANDICAP CERTIFICATE 2026

PHRF-SS, LLC., PO Box 347021, Cleveland, OH 44134

<http://phrfss.org>

**HCP (Spinnaker):** 105 sec/nm  
**NSP (Non-Spinnaker):** 113 sec/nm  
**PPF (Perf Prediction Factor):** 9.94  
**TCF (Time Correction Factor):** 1.0326  
**CRWT (Crew Weight Limit):** 2746 LBS.

**YACHT NAME:** HUMA  
**DESIGN:** JEAN 50 DS SD  
**OWNER:** Marc Uhrich  
**CERTIFICATE:** **STND**  
**CLASSIFICATION:** DISP  
**SAIL NO:** 50  
**POWER:** IB  
**YACHT CLUB:** EWYC

**LOA:** 49 FT.  
**LWL:** 43 FT.  
**BEAM:** 15 FT.  
**DRAFT:** 5.54 FT.  
**DISPLACEMENT:** 29542 LBS.  
**BALLAST:** 9038 LBS.  
**SAIL AREA:** 994 SQ. FT.  
**THS:** 8.79 KN.

**I:** 55.77 FT.  
**ISP:** 55.77 FT.  
**J:** 18.63 FT.  
**JSP/TPS:** 18.63 FT.  
**P:** 51.67 FT.  
**E:** 18.37 FT.

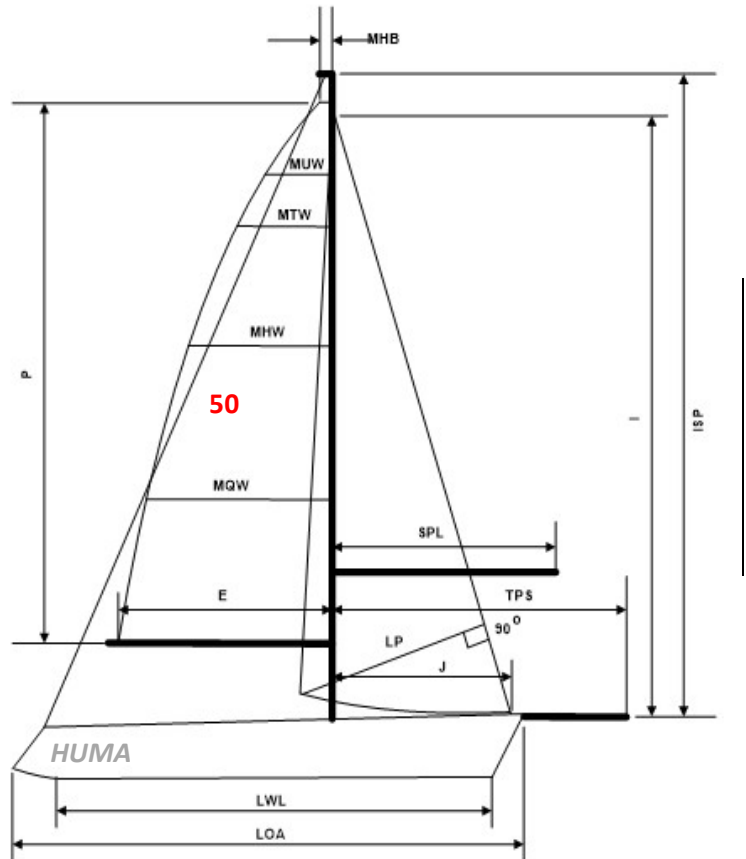

## HANDICAP ADJUSTMENTS

+3 RFG / +9 RFM / 100% Asym declared

*Adjustments must be requested by the owner and are only made based on visual inspection and/or physical measurement by an authorized PHRF-SS measurer.*

Owner Signature: \_\_\_\_\_

*My signature attests to the fact that all the information contained on this certificate is true and correct to the best of my knowledge and that I have not made any modifications to the boat which have not been reported to PHRF-SS.*

**Certificate Issue: 5/19/2026**

**Certificate Expires: 3/31/2027**



# SOUTH SHORE PHRF HANDICAP CERTIFICATE 2026

PHRF-SS, LLC., PO Box 347021, Cleveland, OH 44134

<http://phrfss.org>

**HCP (Spinnaker): 186 sec/nm**  
**NSP (Non-Spinnaker): 196 sec/nm**  
**PPF (Perf Prediction Factor): 17.12**  
**TCF (Time Correction Factor): 0.9174**  
**CRWT (Crew Weight Limit): 1714 LBS.**

**YACHT NAME:** INTO THE MYSTIC  
**DESIGN:** S2 9.2A  
**OWNER:** Timothy Vining  
**CERTIFICATE:** **STND**  
**CLASSIFICATION:** DISP  
**SAIL NO:** 25344  
**POWER:** IB  
**YACHT CLUB:** EWYC

**LOA:** 30 FT.  
**LWL:** 25 FT.  
**BEAM:** 10 FT.  
**DRAFT:** 4.92 FT.  
**DISPLACEMENT:** 9800 LBS.  
**BALLAST:** 4000 LBS.  
**SAIL AREA:** 468 SQ. FT.  
**THS:** 6.70 KN.

**I:** 40.00 FT.  
**ISP:** 40.00 FT.  
**J:** 13.00 FT.  
**JSP/TPS:** 13.00 FT.  
**P:** 34.00 FT.  
**E:** 12.25 FT.

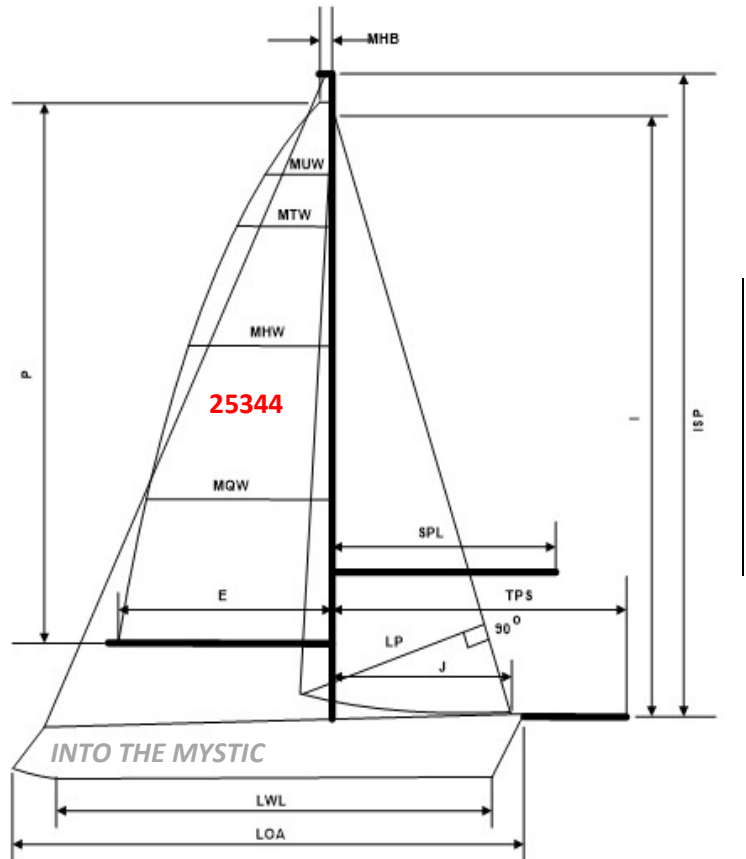

## HANDICAP ADJUSTMENTS

+3RFG / +9 3BX

*Adjustments must be requested by the owner and are only made based on visual inspection and/or physical measurement by an authorized PHRF-SS measurer.*

Owner Signature: \_\_\_\_\_

*My signature attests to the fact that all the information contained on this certificate is true and correct to the best of my knowledge and that I have not made any modifications to the boat which have not been reported to PHRF-SS.*

**Certificate Issue: 5/25/2026**

**Certificate Expires: 3/31/2027**



# SOUTH SHORE PHRF HANDICAP CERTIFICATE 2026

PHRF-SS, LLC., PO Box 347021, Cleveland, OH 44134

<http://phrfss.org>

**HCP (Spinnaker):** 48 sec/nm  
**NSP (Non-Spinnaker):** 58 sec/nm  
**PPF (Perf Prediction Factor):** 7.00  
**TCF (Time Correction Factor):** 1.1327  
**CRWT (Crew Weight Limit):** 2393 LBS.

**YACHT NAME:** VIVA LA VIDA  
**DESIGN:** J-120 AL ODR  
**OWNER:** Tim Yanda  
**CERTIFICATE:** **ODR**  
**CLASSIFICATION:** DISP  
**SAIL NO:** 46722  
**POWER:** IB  
**YACHT CLUB:** EWYC

**LOA:** 40 FT.  
**LWL:** 35 FT.  
**BEAM:** 12 FT.  
**DRAFT:** 7.00 FT.  
**DISPLACEMENT:** 13900 LBS.  
**BALLAST:** 6000 LBS.  
**SAIL AREA:** 780 SQ. FT.  
**THS:** 7.87 KN.

**I:** 50.50 FT.  
**ISP:** 52.00 FT.  
**J:** 14.50 FT.  
**JSP/TPS:** 21.50 FT.  
**P:** 46.50 FT.  
**E:** 17.80 FT.

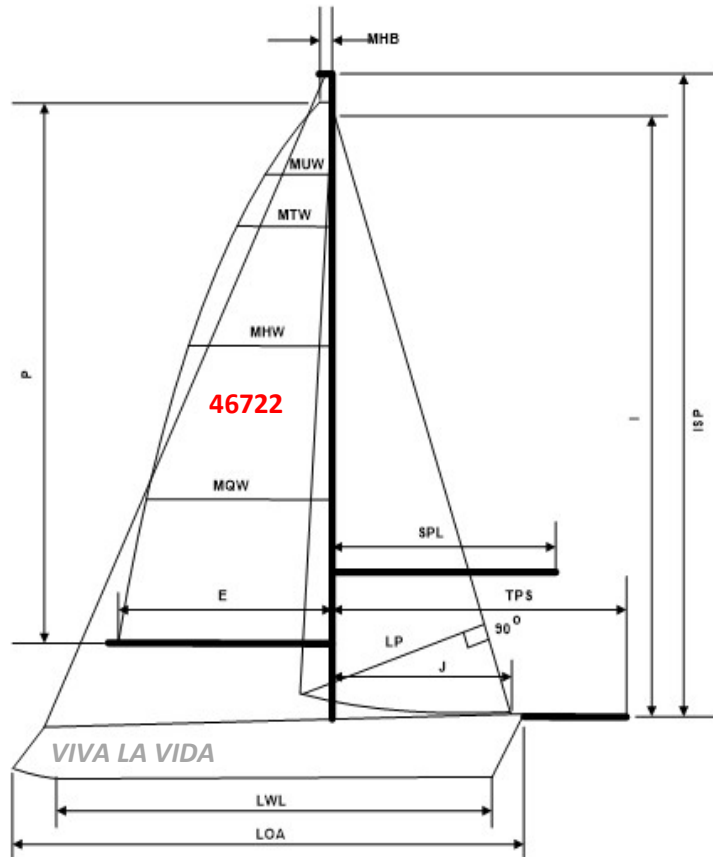

## HANDICAP ADJUSTMENTS

*Adjustments must be requested by the owner and are only made based on visual inspection and/or physical measurement by an authorized PHRF-SS measurer.*

Owner Signature: \_\_\_\_\_

*My signature attests to the fact that all the information contained on this certificate is true and correct to the best of my knowledge and that I have not made any modifications to the boat which have not been reported to PHRF-SS.*

**Certificate Issue: 3/12/2026**

**Certificate Expires: 3/31/2027**



# SOUTH SHORE PHRF HANDICAP CERTIFICATE 2026

PHRF-SS, LLC., PO Box 347021, Cleveland, OH 44134

<http://phrfss.org>

**HCP (Spinnaker):** 39 sec/nm  
**NSP (Non-Spinnaker):** 50 sec/nm  
**PPF (Perf Prediction Factor):** 5.04  
**TCF (Time Correction Factor):** 1.1503  
**CRWT (Crew Weight Limit):** 2230 LBS.

**YACHT NAME:** BLACK SEAL  
**DESIGN:** J-111  
**OWNER:** Seth Young  
**CERTIFICATE:** ODR  
**CLASSIFICATION:** HPRF  
**SAIL NO:** 111  
**POWER:** IB  
**YACHT CLUB:** LYC

**LOA:** 36 FT.  
**LWL:** 33 FT.  
**BEAM:** 11 FT.  
**DRAFT:** 7.18 FT.  
**DISPLACEMENT:** 9370 LBS.  
**BALLAST:** 3516 LBS.  
**SAIL AREA:** 659 SQ. FT.  
**THS:** 7.66 KN.

**I:** 47.74 FT.  
**ISP:** 51.23 FT.  
**J:** 13.85 FT.  
**JSP/TPS:** 21.33 FT.  
**P:** 45.24 FT.  
**E:** 14.50 FT.

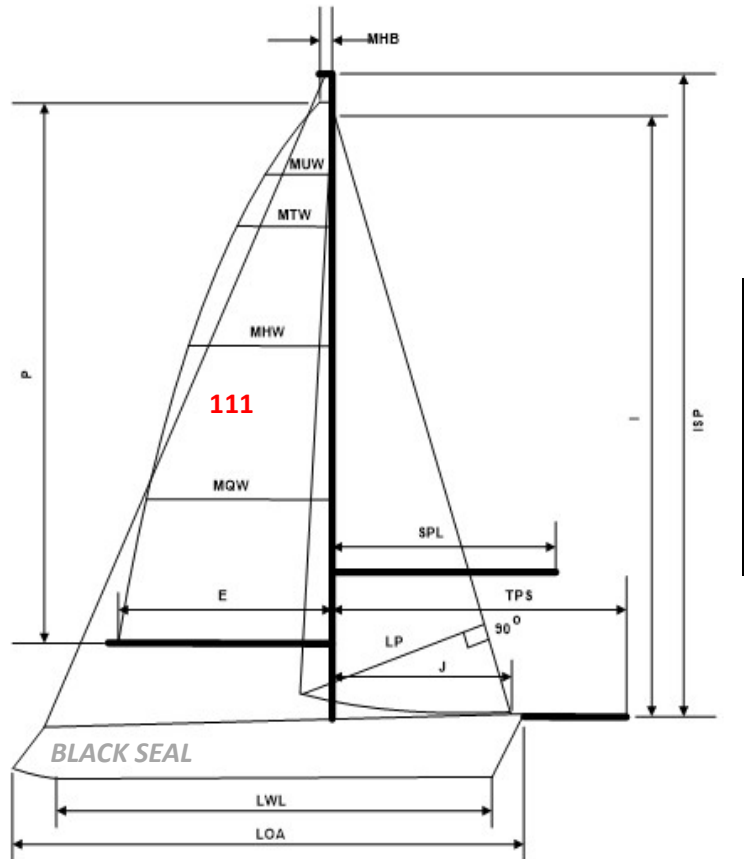

## HANDICAP ADJUSTMENTS

106% JIB, 130 SQM (1399 SQ. FT)

*Adjustments must be requested by the owner and are only made based on visual inspection and/or physical measurement by an authorized PHRF-SS measurer.*

Owner Signature: \_\_\_\_\_

*My signature attests to the fact that all the information contained on this certificate is true and correct to the best of my knowledge and that I have not made any modifications to the boat which have not been reported to PHRF-SS.*

**Certificate Issue: 3/22/2026**

**Certificate Expires: 3/31/2027**