



SOUTH SHORE PHRF HANDICAP CERTIFICATE

PHRF-SS, LLC., PO Box 347021, Cleveland, OH 44134

<http://phrfss.org>

HCP (Handicap): -27 sec/nm
 JAM (Jib & Main): -17 sec/nm
 PPF (Perf Prediction Factor): 5.66
 TCF (Time Correction Factor): 1.4028

CREW WEIGHT LIMIT: 3116 LBS.

YACHT NAME: **EAGLE**
 DESIGN: HINCKLEY BRM 50
 OWNER: Dave Banyard
 CERTIFICATE: **PRLM**
 CLASSIFICATION: DSPL
 SAIL NO: 50015
 POWER: IB
 CLUB: VYC

LOA: 49.74 FT.
 LWL: 45.20 FT.
 BEAM: 14.00 FT.
 DRAFT: 11.70 FT.
 DISPLACEMENT: 29000 LBS.
 BALLAST: 9500 LBS.
 SAIL AREA: 1455 SQ. FT.
 BASE SPIN: 2187 SQ. FT
 EST. FORESTAY: 78.21 FT.

I: 70.21 FT.
 ISP: 75.71 FT.
 J: 19.62 FT.
 JSP/TPS: 25.41 FT.
 P: 69.00 FT.
 E: 22.21 FT.
 SADR: 24.76
 DLR: 140.20

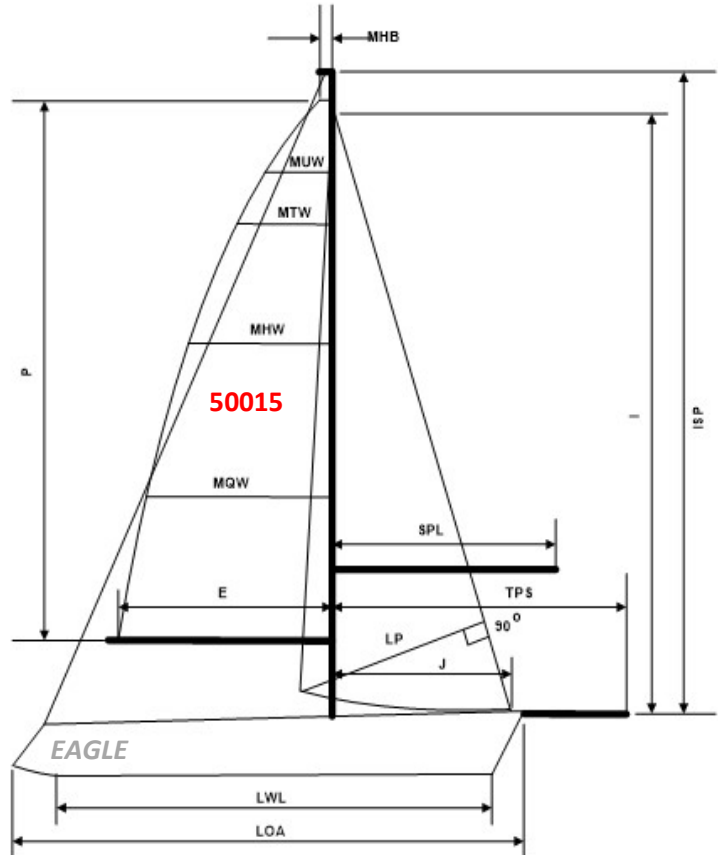

HANDICAP ADJUSTMENTS

+3 BOW THRUST

Adjustments must be requested by the owner and are only made based on visual inspection and/or physical measurement by an authorized PHRF-SS measurer. Fixed Prop credit is for 3-bladed or more fixed prop in aperture or on exposed strut. Asymmetric credit is for an aftermarket sprit pole per Section 20 – Asymmetric Spinnakers. If Asymmetric Credit is given, a symmetrical spinnaker may not be flown at any event designated PHRF-SS. Codes appear in Section 8 - Handicap Adjustments of the PHRF-SS Rules & Bylaws.

Owner Signature: _____

My signature attests to the fact that all the information contained on this certificate is true and correct to the best of my knowledge and that I have not made any modifications to the boat which have not been reported to PHRF-SS.

Certificate Issue: 8/5/2024

Certificate Expires: 3/31/2025



SOUTH SHORE PHRF HANDICAP CERTIFICATE

PHRF-SS, LLC., PO Box 347021, Cleveland, OH 44134

<http://phrfss.org>

HCP (Handicap): 150 sec/nm
JAM (Jib & Main): 156 sec/nm
PPF (Perf Prediction Factor): 9.58
TCF (Time Correction Factor): 0.9628

CREW WEIGHT LIMIT: 1763 LBS.

YACHT NAME: SOLIDARITY
DESIGN: J-30
OWNER: Paul Blonski
CERTIFICATE: STND
CLASSIFICATION: DSPL
SAIL NO: 84
POWER: IB
CLUB: EWYC

LOA: 29.92 FT.
LWL: 25.00 FT.
BEAM: 11.20 FT.
DRAFT: 5.25 FT.
DISPLACEMENT: 6700 LBS.
BALLAST: 2100 LBS.
SAIL AREA: 443 SQ. FT.
BASE SPIN: 591 SQ. FT
EST. FORESTAY: 36.07 FT.

I: 34.00 FT.
ISP: 34.19 FT.
J: 11.50 FT.
JSP/TPS: 12.50 FT.
P: 38.00 FT.
E: 13.00 FT.
SADR: 19.98
DLR: 191.43

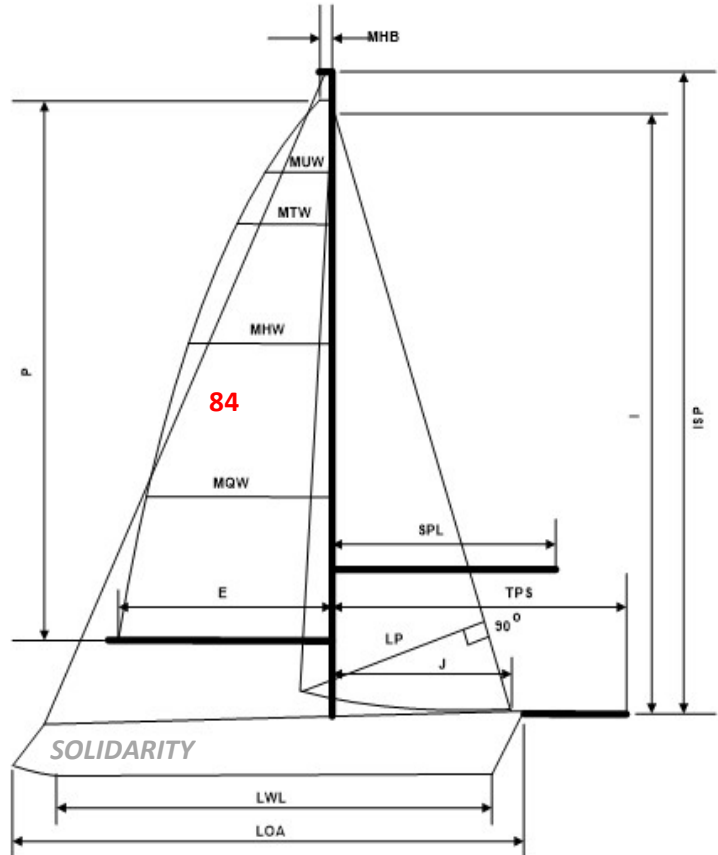

HANDICAP ADJUSTMENTS

+3 RFG

Adjustments must be requested by the owner and are only made based on visual inspection and/or physical measurement by an authorized PHRF-SS measurer. Fixed Prop credit is for 3-bladed or more fixed prop in aperture or on exposed strut. Asymmetric credit is for an aftermarket sprit pole per Section 20 – Asymmetric Spinnakers. If Asymmetric Credit is given, a symmetrical spinnaker may not be flown at any event designated PHRF-SS. Codes appear in Section 8 - Handicap Adjustments of the PHRF-SS Rules & Bylaws.

Owner Signature: _____

My signature attests to the fact that all the information contained on this certificate is true and correct to the best of my knowledge and that I have not made any modifications to the boat which have not been reported to PHRF-SS.

Certificate Issue: 2/27/2024

Certificate Expires: 3/31/2025



SOUTH SHORE PHRF HANDICAP CERTIFICATE

PHRF-SS, LLC., PO Box 347021, Cleveland, OH 44134

<http://phrfss.org>

HCP (Handicap): 93 sec/nm
JAM (Jib & Main): 101 sec/nm
PPF (Perf Prediction Factor): 11.43
TCF (Time Correction Factor): 1.0710

CREW WEIGHT LIMIT: 2388 LBS.

YACHT NAME: VOYAGER
DESIGN: TARTAN 4100 TM SD
OWNER: Hunter Chisholm
CERTIFICATE: STND
CLASSIFICATION: DSPL
SAIL NO: 4100
POWER: IB
CLUB: LYC

LOA: 41.25 FT.
LWL: 35.75 FT.
BEAM: 13.50 FT.
DRAFT: 5.33 FT.
DISPLACEMENT: 20400 LBS.
BALLAST: 8000 LBS.
SAIL AREA: 811 SQ. FT.
BASE SPIN: 1198 SQ. FT
EST. FORESTAY: 56.04 FT.

I: 54.00 FT.
ISP: 54.00 FT.
J: 15.00 FT.
JSP/TPS: 15.00 FT.
P: 47.75 FT.
E: 17.00 FT.
SADR: 17.44
DLR: 199.32

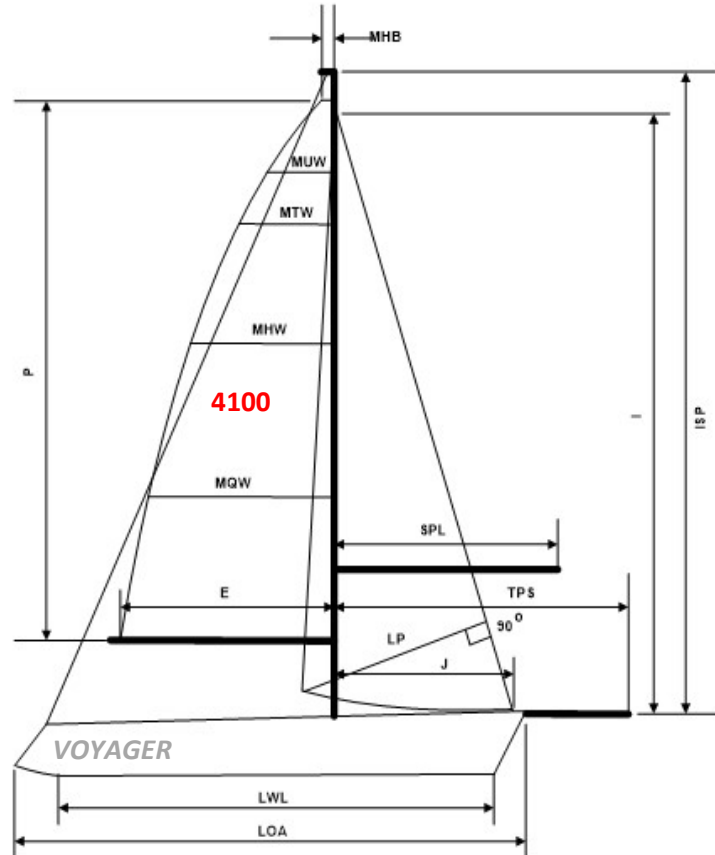

HANDICAP ADJUSTMENTS

Adjustments must be requested by the owner and are only made based on visual inspection and/or physical measurement by an authorized PHRF-SS measurer. Fixed Prop credit is for 3-bladed or more fixed prop in aperture or on exposed strut. Asymmetric credit is for an aftermarket sprit pole per Section 20 – Asymmetric Spinnakers. If Asymmetric Credit is given, a symmetrical spinnaker may not be flown at any event designated PHRF-SS. Codes appear in Section 8 - Handicap Adjustments of the PHRF-SS Rules & Bylaws.

Owner Signature: _____

My signature attests to the fact that all the information contained on this certificate is true and correct to the best of my knowledge and that I have not made any modifications to the boat which have not been reported to PHRF-SS.

Certificate Issue: 3/21/2024

Certificate Expires: 3/31/2025



SOUTH SHORE PHRF HANDICAP CERTIFICATE

PHRF-SS, LLC., PO Box 347021, Cleveland, OH 44134

<http://phrfss.org>

HCP (Handicap): 225 sec/nm
JAM (Jib & Main): 233 sec/nm
PPF (Perf Prediction Factor): 12.24
TCF (Time Correction Factor): 0.8498

CREW WEIGHT LIMIT: 1411 LBS.

YACHT NAME: MYSTICAL
DESIGN: CAL 25-1 OB
OWNER: Colahan-Sederstrom
CERTIFICATE: STND
CLASSIFICATION: DSPL
SAIL NO: 1668
POWER: OB
CLUB: EWYC

LOA: 25.00 FT.
LWL: 20.00 FT.
BEAM: 8.00 FT.
DRAFT: 4.00 FT.
DISPLACEMENT: 4000 LBS.
BALLAST: 1700 LBS.
SAIL AREA: 287 SQ. FT.
BASE SPIN: 448 SQ. FT
EST. FORESTAY: 31.43 FT.

I: 29.80 FT.
ISP: 29.80 FT.
J: 10.00 FT.
JSP/TPS: 10.00 FT.
P: 25.00 FT.
E: 11.00 FT.
SADR: 18.24
DLR: 223.21

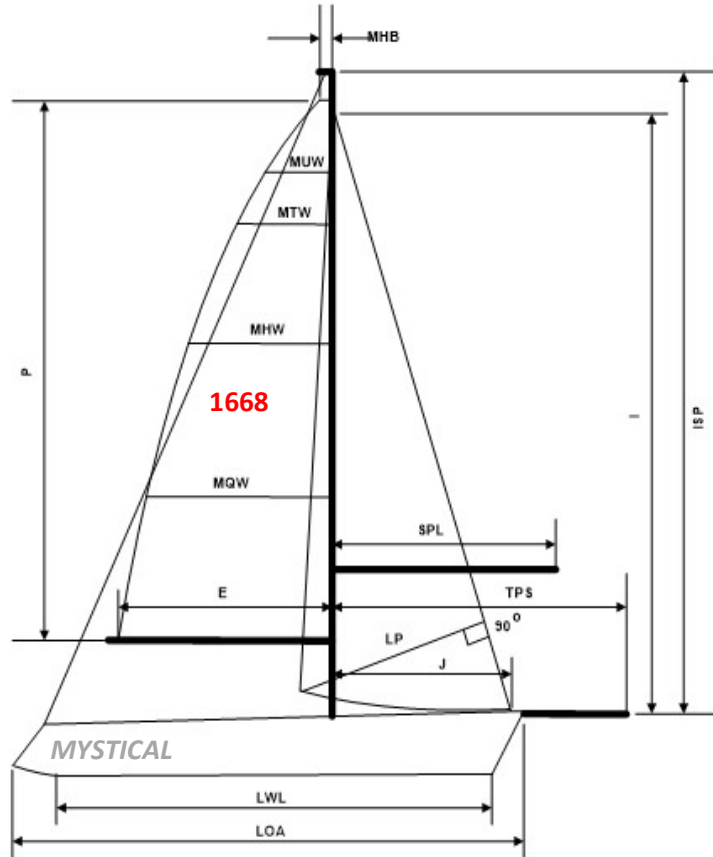

HANDICAP ADJUSTMENTS

Adjustments must be requested by the owner and are only made based on visual inspection and/or physical measurement by an authorized PHRF-SS measurer. Fixed Prop credit is for 3-bladed or more fixed prop in aperture or on exposed strut. Asymmetric credit is for an aftermarket sprit pole per Section 20 – Asymmetric Spinnakers. If Asymmetric Credit is given, a symmetrical spinnaker may not be flown at any event designated PHRF-SS. Codes appear in Section 8 - Handicap Adjustments of the PHRF-SS Rules & Bylaws.

Owner Signature: _____

My signature attests to the fact that all the information contained on this certificate is true and correct to the best of my knowledge and that I have not made any modifications to the boat which have not been reported to PHRF-SS.

Certificate Issue: 8/1/2024

Certificate Expires: 3/31/2025



SOUTH SHORE PHRF HANDICAP CERTIFICATE

PHRF-SS, LLC., PO Box 347021, Cleveland, OH 44134

<http://phrfss.org>

HCP (Handicap): 168 sec/nm
JAM (Jib & Main): 176 sec/nm
PPF (Perf Prediction Factor): 9.65
TCF (Time Correction Factor): 0.9330

CREW WEIGHT LIMIT: 1849 LBS.

YACHT NAME: MOYA-MANZI
DESIGN: OCEANIS (BENET) 321
OWNER: Mark Corson
CERTIFICATE: STND
CLASSIFICATION: DSPL
SAIL NO: 60661
POWER: IB
CLUB: EWYC

LOA: 32.64 FT.
LWL: 29.36 FT.
BEAM: 11.22 FT.
DRAFT: 4.26 FT.
DISPLACEMENT: 9700 LBS.
BALLAST: 3000 LBS.
SAIL AREA: 502 SQ. FT.
BASE SPIN: 767 SQ. FT
EST. FORESTAY: 43.76 FT.

I: 42.00 FT.
ISP: 42.00 FT.
J: 12.30 FT.
JSP/TPS: 12.30 FT.
P: 35.90 FT.
E: 13.60 FT.
SADR: 17.73
DLR: 171.10

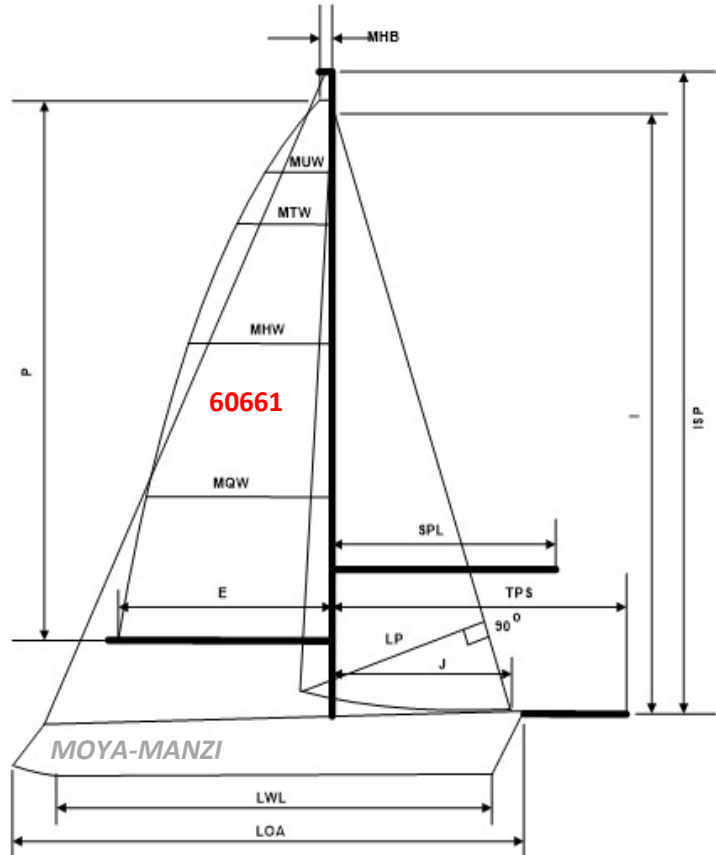

HANDICAP ADJUSTMENTS

+6RFG

Adjustments must be requested by the owner and are only made based on visual inspection and/or physical measurement by an authorized PHRF-SS measurer. Fixed Prop credit is for 3-bladed or more fixed prop in aperture or on exposed strut. Asymmetric credit is for an aftermarket sprit pole per Section 20 – Asymmetric Spinnakers. If Asymmetric Credit is given, a symmetrical spinnaker may not be flown at any event designated PHRF-SS. Codes appear in Section 8 - Handicap Adjustments of the PHRF-SS Rules & Bylaws.

Owner Signature: _____

My signature attests to the fact that all the information contained on this certificate is true and correct to the best of my knowledge and that I have not made any modifications to the boat which have not been reported to PHRF-SS.

Certificate Issue: 2/27/2024

Certificate Expires: 3/31/2025



SOUTH SHORE PHRF HANDICAP CERTIFICATE

PHRF-SS, LLC., PO Box 347021, Cleveland, OH 44134

<http://phrfss.org>

HCP (Handicap): 166 sec/nm
JAM (Jib & Main): 174 sec/nm
PPF (Perf Prediction Factor): 14.68
TCF (Time Correction Factor): 0.9362

CREW WEIGHT LIMIT: 1855 LBS.

YACHT NAME: SNIPERDOG
DESIGN: CAT 320 WK
OWNER: Phillip Dubiel
CERTIFICATE: **STND**
CLASSIFICATION: DSPL
SAIL NO: 365
POWER: IB
CLUB: EWYC

LOA: 32.5 FT.
LWL: 28 FT.
BEAM: 11.75 FT.
DRAFT: 4.3 FT.
DISPLACEMENT: 11700 LBS.
BALLAST: 4400 LBS.
SAIL AREA: 520 SQ. FT.
BASE SPIN: 796 SQ. FT
EST. FORESTAY: 45.29 FT.

I: 43.58 FT.
ISP: 43.58 FT.
J: 12.33 FT.
JSP/TPS: 12.33 FT.
P: 38 FT.
E: 13.25 FT.
SADR: 16.21
DLR: 237.94

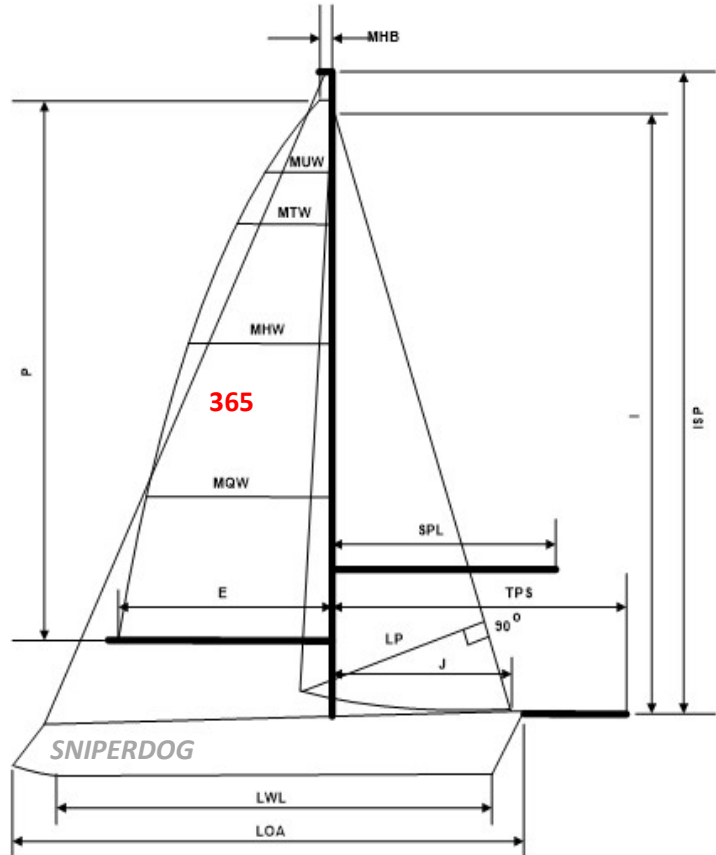

HANDICAP ADJUSTMENTS

Adjustments must be requested by the owner and are only made based on visual inspection and/or physical measurement by an authorized PHRF-SS measurer. Fixed Prop credit is for 3-bladed or more fixed prop in aperture or on exposed strut. Asymmetric credit is for an aftermarket sprit pole per Section 20 – Asymmetric Spinnakers. If Asymmetric Credit is given, a symmetrical spinnaker may not be flown at any event designated PHRF-SS. Codes appear in Section 8 - Handicap Adjustments of the PHRF-SS Rules & Bylaws.

Owner Signature: _____

My signature attests to the fact that all the information contained on this certificate is true and correct to the best of my knowledge and that I have not made any modifications to the boat which have not been reported to PHRF-SS.

Certificate Issue: 2/27/2024

Certificate Expires: 3/31/2025



SOUTH SHORE PHRF HANDICAP CERTIFICATE

PHRF-SS, LLC., PO Box 347021, Cleveland, OH 44134

<http://phrfss.org>

HCP (Handicap): 81 sec/nm
JAM (Jib & Main): 89 sec/nm
PPF (Perf Prediction Factor): 2.29
TCF (Time Correction Factor): 1.0969

CREW WEIGHT LIMIT: 1613 LBS.

YACHT NAME: EVIL DUER
DESIGN: MELGES 24
OWNER: Nate Duer
CERTIFICATE: STND
CLASSIFICATION: HPRF
SAIL NO: 106
POWER: OB
CLUB: EWYC

LOA: 24.00 FT.
LWL: 22.00 FT.
BEAM: 8.20 FT.
DRAFT: 5.00 FT.
DISPLACEMENT: 1750 LBS.
BALLAST: 650 LBS.
SAIL AREA: 291 SQ. FT.
BASE SPIN: 371 SQ. FT
EST. FORESTAY: 32.78 FT.

I: 27.85 FT.
ISP: 31.80 FT.
J: 7.95 FT.
JSP/TPS: 12.00 FT.
P: 28.90 FT.
E: 12.45 FT.
SADR: 32.09
DLR: 73.37

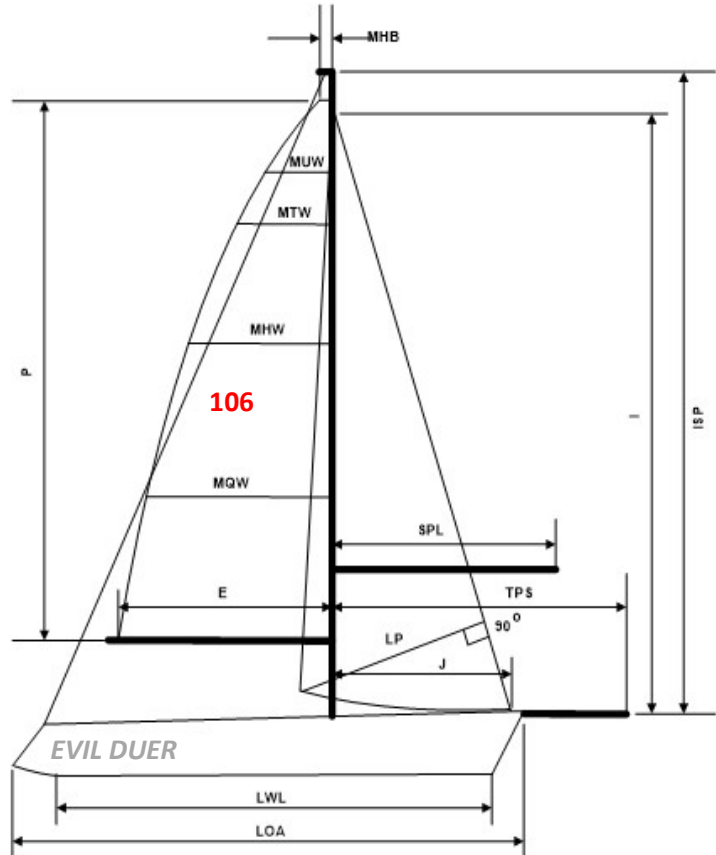

HANDICAP ADJUSTMENTS

Adjustments must be requested by the owner and are only made based on visual inspection and/or physical measurement by an authorized PHRF-SS measurer. Fixed Prop credit is for 3-bladed or more fixed prop in aperture or on exposed strut. Asymmetric credit is for an aftermarket sprit pole per Section 20 – Asymmetric Spinnakers. If Asymmetric Credit is given, a symmetrical spinnaker may not be flown at any event designated PHRF-SS. Codes appear in Section 8 - Handicap Adjustments of the PHRF-SS Rules & Bylaws.

Owner Signature: _____

My signature attests to the fact that all the information contained on this certificate is true and correct to the best of my knowledge and that I have not made any modifications to the boat which have not been reported to PHRF-SS.

Certificate Issue: 3/24/2024

Certificate Expires: 3/31/2025



SOUTH SHORE PHRF HANDICAP CERTIFICATE

PHRF-SS, LLC., PO Box 347021, Cleveland, OH 44134

<http://phrfss.org>

HCP (Handicap): 90 sec/nm
JAM (Jib & Main): 100 sec/nm
PPF (Perf Prediction Factor): 6.74
TCF (Time Correction Factor): 1.0773

CREW WEIGHT LIMIT: 2061 LBS.

YACHT NAME: OVATION
DESIGN: J-105 ODR
OWNER: Tom & Cindy Einhouse
CERTIFICATE: ODR
CLASSIFICATION: DSPL
SAIL NO: 393
POWER: IB
CLUB: EWYC

LOA: 34.50 FT.
LWL: 29.50 FT.
BEAM: 11.00 FT.
DRAFT: 6.50 FT.
DISPLACEMENT: 8575 LBS.
BALLAST: 3400 LBS.
SAIL AREA: 577 SQ. FT.
BASE SPIN: 851 SQ. FT
EST. FORESTAY: 44.21 FT.

I: 40.60 FT.
ISP: 42.10 FT.
J: 13.50 FT.
JSP/TPS: 19.00 FT.
P: 41.50 FT.
E: 14.60 FT.
SADR: 22.11
DLR: 149.11

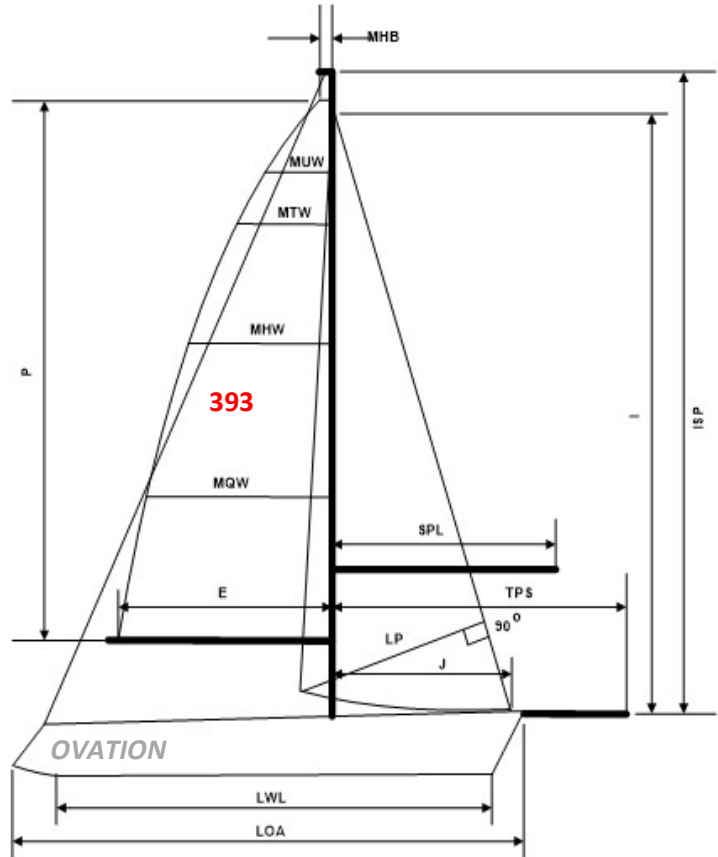

HANDICAP ADJUSTMENTS

ODR 102% JIB/89 SQM ASYM

Adjustments must be requested by the owner and are only made based on visual inspection and/or physical measurement by an authorized PHRF-SS measurer. Fixed Prop credit is for 3-bladed or more fixed prop in aperture or on exposed strut. Asymmetric credit is for an aftermarket sprit pole per Section 20 – Asymmetric Spinnakers. If Asymmetric Credit is given, a symmetrical spinnaker may not be flown at any event designated PHRF-SS. Codes appear in Section 8 - Handicap Adjustments of the PHRF-SS Rules & Bylaws.

Owner Signature: _____

My signature attests to the fact that all the information contained on this certificate is true and correct to the best of my knowledge and that I have not made any modifications to the boat which have not been reported to PHRF-SS.

Certificate Issue: 2/28/2024

Certificate Expires: 3/31/2025



SOUTH SHORE PHRF HANDICAP CERTIFICATE

PHRF-SS, LLC., PO Box 347021, Cleveland, OH 44134

<http://phrfss.org>

HCP (Handicap): 126 sec/nm
JAM (Jib & Main): 129 sec/nm
PPF (Perf Prediction Factor): 13.87
TCF (Time Correction Factor): 1.0056

CREW WEIGHT LIMIT: 2179 LBS.

YACHT NAME: SCORPION
DESIGN: R-CLASS
OWNER: Charles Essi
CERTIFICATE: CLUB
CLASSIFICATION: DSPL
SAIL NO: 0
POWER: OB
CLUB: CYC

LOA: 39.15 FT.
LWL: 27.00 FT.
BEAM: 6.92 FT.
DRAFT: 5.72 FT.
DISPLACEMENT: 11500 LBS.
BALLAST: 3450 LBS.
SAIL AREA: 597 SQ. FT.
BASE SPIN: 988 SQ. FT
EST. FORESTAY: 38.27 FT.

I: 36.50 FT.
ISP: 36.50 FT.
J: 11.50 FT.
JSP/TPS: 12.58 FT.
P: 43.00 FT.
E: 18.00 FT.
SADR: 18.81
DLR: 260.83

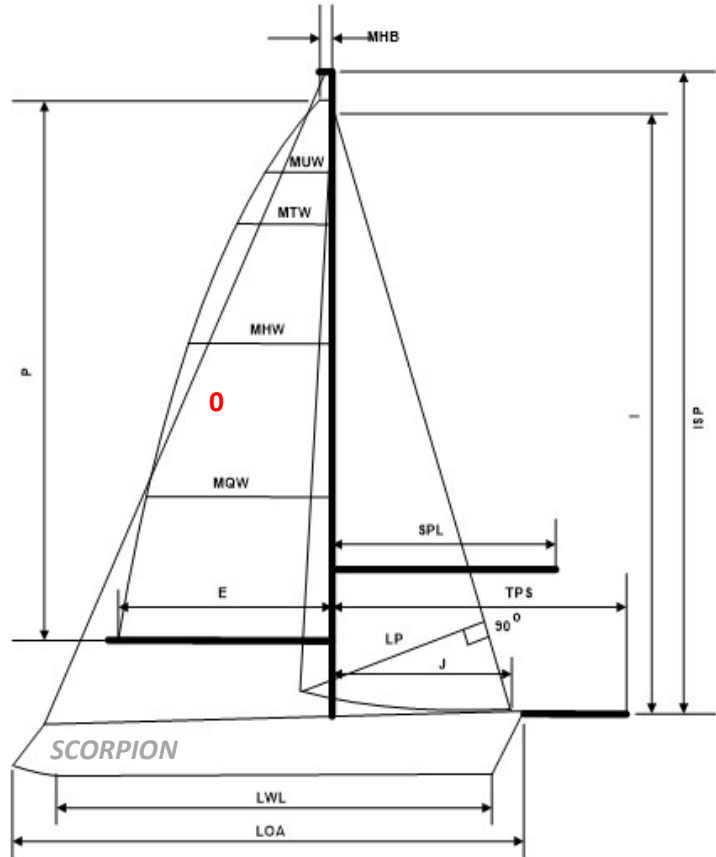

HANDICAP ADJUSTMENTS

-3GADJ / -6SADJ

Adjustments must be requested by the owner and are only made based on visual inspection and/or physical measurement by an authorized PHRF-SS measurer. Fixed Prop credit is for 3-bladed or more fixed prop in aperture or on exposed strut. Asymmetric credit is for an aftermarket sprit pole per Section 20 – Asymmetric Spinnakers. If Asymmetric Credit is given, a symmetrical spinnaker may not be flown at any event designated PHRF-SS. Codes appear in Section 8 - Handicap Adjustments of the PHRF-SS Rules & Bylaws.

Owner Signature: _____

My signature attests to the fact that all the information contained on this certificate is true and correct to the best of my knowledge and that I have not made any modifications to the boat which have not been reported to PHRF-SS.

Certificate Issue: 6/17/2024

Certificate Expires: 3/31/2025



SOUTH SHORE PHRF HANDICAP CERTIFICATE

PHRF-SS, LLC., PO Box 347021, Cleveland, OH 44134

<http://phrfss.org>

HCP (Handicap): 177 sec/nm
JAM (Jib & Main): 182 sec/nm
PPF (Perf Prediction Factor): 10.61
TCF (Time Correction Factor): 0.9188

CREW WEIGHT LIMIT: 1541 LBS.

YACHT NAME: UPSTART
DESIGN: S2 7.9 DB IB
OWNER: Jack Filak
CERTIFICATE: STND
CLASSIFICATION: DSPL
SAIL NO: 2521
POWER: IB
CLUB: EWYC

LOA: 25.92 FT.
LWL: 21.67 FT.
BEAM: 9.00 FT.
DRAFT: 5.00 FT.
DISPLACEMENT: 4577 LBS.
BALLAST: 1550 LBS.
SAIL AREA: 325 SQ. FT.
BASE SPIN: 432 SQ. FT
EST. FORESTAY: 31.95 FT.

I: 30.50 FT.
ISP: 30.50 FT.
J: 9.50 FT.
JSP/TPS: 9.50 FT.
P: 29.42 FT.
E: 12.25 FT.
SADR: 18.92
DLR: 200.80

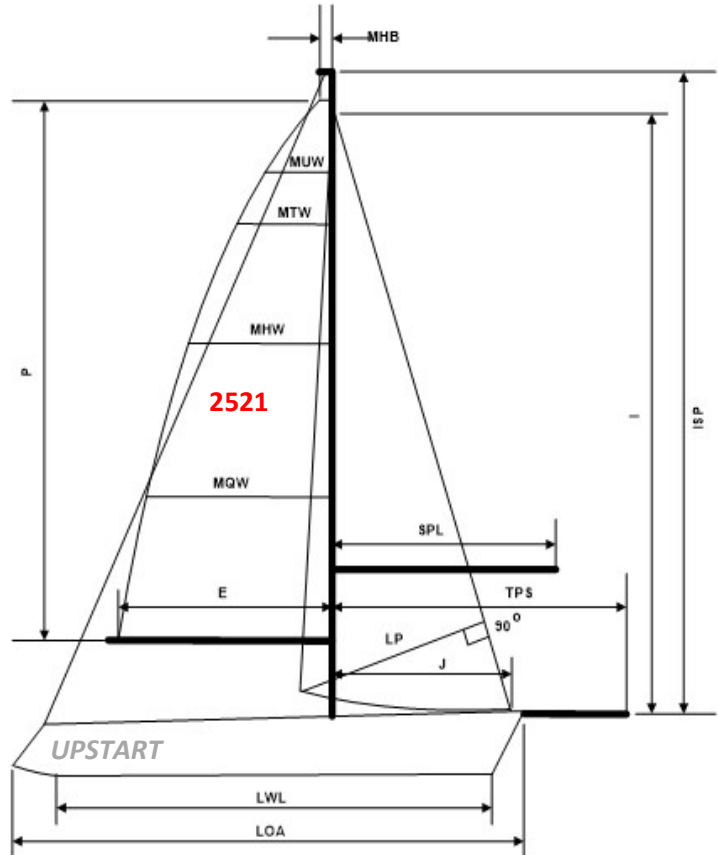

HANDICAP ADJUSTMENTS

Adjustments must be requested by the owner and are only made based on visual inspection and/or physical measurement by an authorized PHRF-SS measurer. Fixed Prop credit is for 3-bladed or more fixed prop in aperture or on exposed strut. Asymmetric credit is for an aftermarket sprit pole per Section 20 – Asymmetric Spinnakers. If Asymmetric Credit is given, a symmetrical spinnaker may not be flown at any event designated PHRF-SS. Codes appear in Section 8 - Handicap Adjustments of the PHRF-SS Rules & Bylaws.

Owner Signature: _____

My signature attests to the fact that all the information contained on this certificate is true and correct to the best of my knowledge and that I have not made any modifications to the boat which have not been reported to PHRF-SS.

Certificate Issue: 7/15/2024

Certificate Expires: 3/31/2025



SOUTH SHORE PHRF HANDICAP CERTIFICATE

PHRF-SS, LLC., PO Box 347021, Cleveland, OH 44134

<http://phrfss.org>

HCP (Handicap): 66 sec/nm
JAM (Jib & Main): 75 sec/nm
PPF (Perf Prediction Factor): 6.06
TCF (Time Correction Factor): 1.1312

CREW WEIGHT LIMIT: 2289 LBS.

YACHT NAME: BREEZIN'
DESIGN: C&C 115 SPRIT
OWNER: Rich Galaska
CERTIFICATE: STND
CLASSIFICATION: DSPL
SAIL NO: 11555
POWER: IB
CLUB: FCYC

LOA: 37.75 FT.
LWL: 33.00 FT.
BEAM: 11.92 FT.
DRAFT: 6.67 FT.
DISPLACEMENT: 11800 LBS.
BALLAST: 4200 LBS.
SAIL AREA: 781 SQ. FT.
BASE SPIN: 1119 SQ. FT
EST. FORESTAY: 54.14 FT.

I: 52.16 FT.
ISP: 52.16 FT.
J: 14.50 FT.
JSP/TPS: 19.00 FT.
P: 49.33 FT.
E: 16.33 FT.
SADR: 24.19
DLR: 146.59

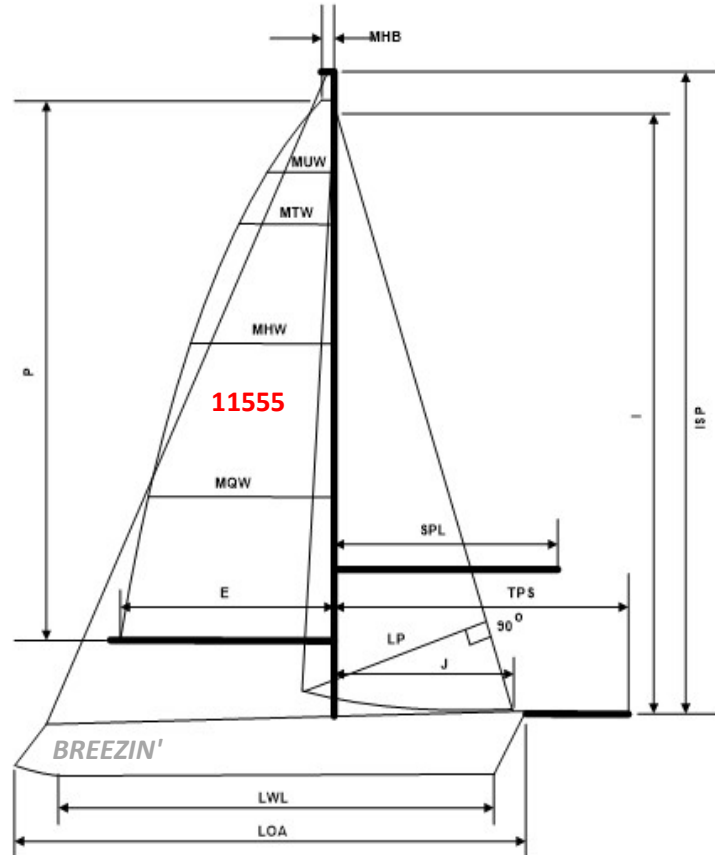

HANDICAP ADJUSTMENTS

Adjustments must be requested by the owner and are only made based on visual inspection and/or physical measurement by an authorized PHRF-SS measurer. Fixed Prop credit is for 3-bladed or more fixed prop in aperture or on exposed strut. Asymmetric credit is for an aftermarket sprit pole per Section 20 – Asymmetric Spinnakers. If Asymmetric Credit is given, a symmetrical spinnaker may not be flown at any event designated PHRF-SS. Codes appear in Section 8 - Handicap Adjustments of the PHRF-SS Rules & Bylaws.

Owner Signature: _____

My signature attests to the fact that all the information contained on this certificate is true and correct to the best of my knowledge and that I have not made any modifications to the boat which have not been reported to PHRF-SS.

Certificate Issue: 4/4/2024

Certificate Expires: 3/31/2025



SOUTH SHORE PHRF HANDICAP CERTIFICATE

PHRF-SS, LLC., PO Box 347021, Cleveland, OH 44134

<http://phrfss.org>

HCP (Handicap): 171 sec/nm
JAM (Jib & Main): 180 sec/nm
PPF (Perf Prediction Factor): 14.12
TCF (Time Correction Factor): 0.9282

CREW WEIGHT LIMIT: 1840 LBS.

YACHT NAME: VERKTADUE
DESIGN: IRWIN 32 CITATION SHOAL
OWNER: Jeff Geisinger
CERTIFICATE: STND
CLASSIFICATION: DSPL
SAIL NO: 321
POWER: IB
CLUB: EWYC

LOA: 32.33 FT.
LWL: 26.75 FT.
BEAM: 11.08 FT.
DRAFT: 4.00 FT.
DISPLACEMENT: 10500 LBS.
BALLAST: 4600 LBS.
SAIL AREA: 518 SQ. FT.
BASE SPIN: 846 SQ. FT.
EST. FORESTAY: 44.98 FT.

I: 43.00 FT.
ISP: 43.00 FT.
J: 13.20 FT.
JSP/TPS: 13.20 FT.
P: 37.50 FT.
E: 12.50 FT.
SADR: 17.35
DLR: 244.89

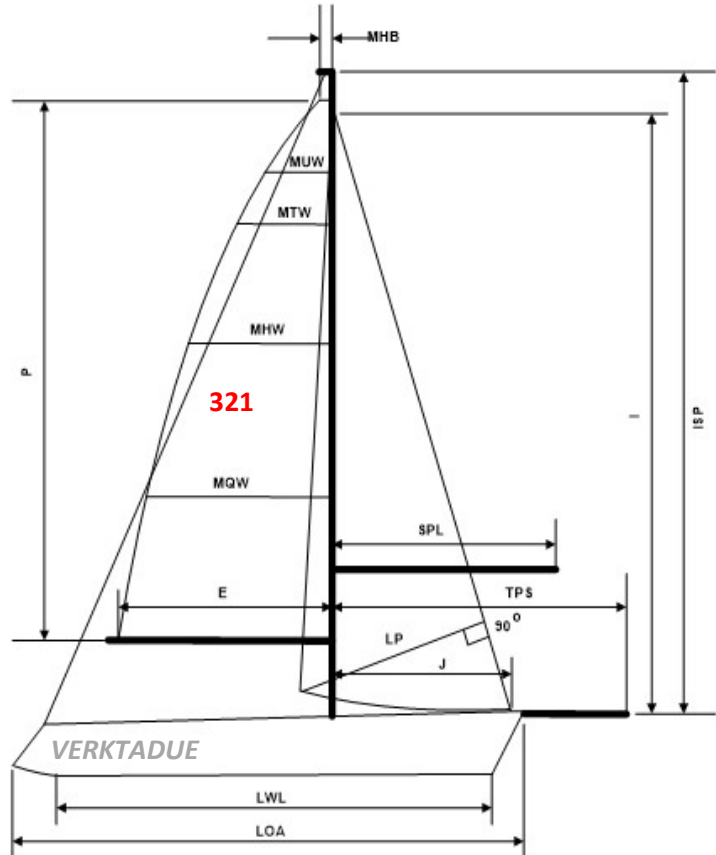

HANDICAP ADJUSTMENTS

+3 RFG

Adjustments must be requested by the owner and are only made based on visual inspection and/or physical measurement by an authorized PHRF-SS measurer. Fixed Prop credit is for 3-bladed or more fixed prop in aperture or on exposed strut. Asymmetric credit is for an aftermarket sprit pole per Section 20 – Asymmetric Spinnakers. If Asymmetric Credit is given, a symmetrical spinnaker may not be flown at any event designated PHRF-SS. Codes appear in Section 8 - Handicap Adjustments of the PHRF-SS Rules & Bylaws.

Owner Signature: _____

My signature attests to the fact that all the information contained on this certificate is true and correct to the best of my knowledge and that I have not made any modifications to the boat which have not been reported to PHRF-SS.

Certificate Issue: 2/28/2024

Certificate Expires: 3/31/2025



SOUTH SHORE PHRF HANDICAP CERTIFICATE

PHRF-SS, LLC., PO Box 347021, Cleveland, OH 44134

<http://phrfss.org>

HCP (Handicap): 135 sec/nm
JAM (Jib & Main): 143 sec/nm
PPF (Perf Prediction Factor): 11.28
TCF (Time Correction Factor): 0.9891

CREW WEIGHT LIMIT: 1802 LBS.

YACHT NAME: SUMMER SCHOOL
DESIGN: S2 9.1
OWNER: Brian Hare
CERTIFICATE: **STND**
CLASSIFICATION: DSPL
SAIL NO: 25115
POWER: IB
CLUB: EWYC

LOA: 29.83 FT.
LWL: 25.00 FT.
BEAM: 10.50 FT.
DRAFT: 5.50 FT.
DISPLACEMENT: 7850 LBS.
BALLAST: 3200 LBS.
SAIL AREA: 489 SQ. FT.
BASE SPIN: 735 SQ. FT
EST. FORESTAY: 43.01 FT.

I: 41.30 FT.
ISP: 41.30 FT.
J: 12.00 FT.
JSP/TPS: 12.00 FT.
P: 35.30 FT.
E: 13.67 FT.
SADR: 19.88
DLR: 224.29

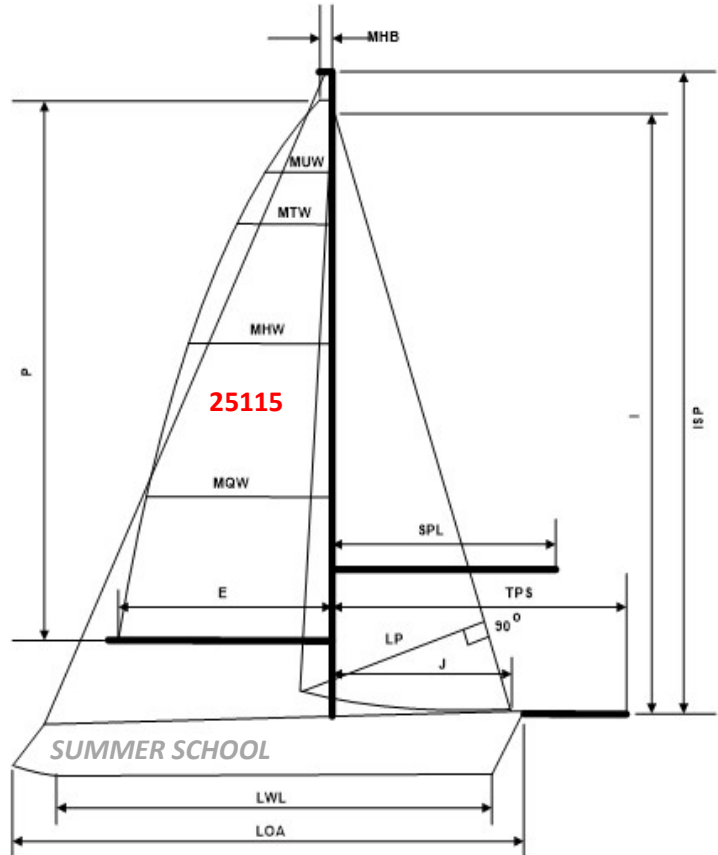

HANDICAP ADJUSTMENTS

+3 RFG

Adjustments must be requested by the owner and are only made based on visual inspection and/or physical measurement by an authorized PHRF-SS measurer. Fixed Prop credit is for 3-bladed or more fixed prop in aperture or on exposed strut. Asymmetric credit is for an aftermarket sprit pole per Section 20 – Asymmetric Spinnakers. If Asymmetric Credit is given, a symmetrical spinnaker may not be flown at any event designated PHRF-SS. Codes appear in Section 8 - Handicap Adjustments of the PHRF-SS Rules & Bylaws.

Owner Signature: _____

My signature attests to the fact that all the information contained on this certificate is true and correct to the best of my knowledge and that I have not made any modifications to the boat which have not been reported to PHRF-SS.

Certificate Issue: 4/25/2024

Certificate Expires: 3/31/2025



SOUTH SHORE PHRF HANDICAP CERTIFICATE

PHRF-SS, LLC., PO Box 347021, Cleveland, OH 44134

<http://phrfss.org>

HCP (Handicap): 195 sec/nm
JAM (Jib & Main): 201 sec/nm
PPF (Perf Prediction Factor): 8.12
TCF (Time Correction Factor): 0.8917

CREW WEIGHT LIMIT: 1398 LBS.

YACHT NAME: TAN TAR A
DESIGN: FIRST (BENET) 235 WK
OWNER: Don Harris
CERTIFICATE: STND
CLASSIFICATION: DSPL
SAIL NO: 174
POWER: OB
CLUB: PIBYC

LOA: 23.33 FT.
LWL: 20.25 FT.
BEAM: 8.17 FT.
DRAFT: 2.75 FT.
DISPLACEMENT: 2936 LBS.
BALLAST: 937 LBS.
SAIL AREA: 249 SQ. FT.
BASE SPIN: 333 SQ. FT
EST. FORESTAY: 29.67 FT.

I: 28.61 FT.
ISP: 28.61 FT.
J: 7.87 FT.
JSP/TPS: 7.87 FT.
P: 26.41 FT.
E: 10.30 FT.
SADR: 19.45
DLR: 157.85

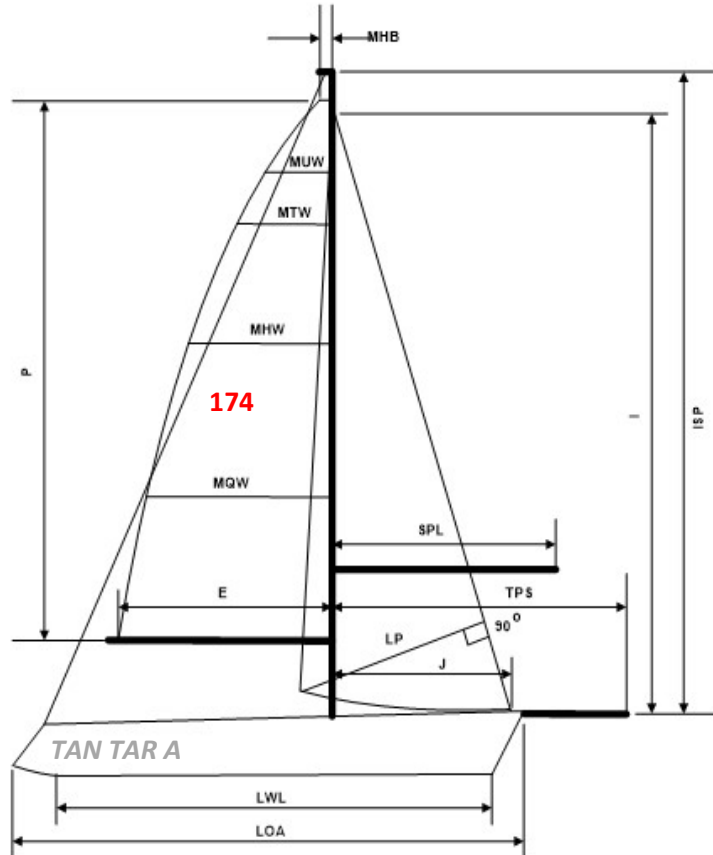

HANDICAP ADJUSTMENTS

-60B

Adjustments must be requested by the owner and are only made based on visual inspection and/or physical measurement by an authorized PHRF-SS measurer. Fixed Prop credit is for 3-bladed or more fixed prop in aperture or on exposed strut. Asymmetric credit is for an aftermarket sprit pole per Section 20 – Asymmetric Spinnakers. If Asymmetric Credit is given, a symmetrical spinnaker may not be flown at any event designated PHRF-SS. Codes appear in Section 8 - Handicap Adjustments of the PHRF-SS Rules & Bylaws.

Owner Signature: _____

My signature attests to the fact that all the information contained on this certificate is true and correct to the best of my knowledge and that I have not made any modifications to the boat which have not been reported to PHRF-SS.

Certificate Issue: 5/12/2024

Certificate Expires: 3/31/2025



SOUTH SHORE PHRF HANDICAP CERTIFICATE

PHRF-SS, LLC., PO Box 347021, Cleveland, OH 44134

<http://phrfss.org>

HCP (Handicap): 48 sec/nm
JAM (Jib & Main): 56 sec/nm
PPF (Perf Prediction Factor): 7.19
TCF (Time Correction Factor): 1.1752

CREW WEIGHT LIMIT: 2380 LBS.

YACHT NAME: CommoHAWK
DESIGN: J-39
OWNER: Conor Hawkins
CERTIFICATE: **STND**
CLASSIFICATION: DSPL
SAIL NO: 43511
POWER: IB
CLUB: EWYC

LOA: 39.42 FT.
LWL: 32.50 FT.
BEAM: 12.42 FT.
DRAFT: 7.25 FT.
DISPLACEMENT: 12900 LBS.
BALLAST: 5900 LBS.
SAIL AREA: 799 SQ. FT.
BASE SPIN: 1230 SQ. FT
EST. FORESTAY: 55.70 FT.

I: 53.50 FT.
ISP: 53.50 FT.
J: 15.50 FT.
JSP/TPS: 15.50 FT.
P: 47.20 FT.
E: 16.30 FT.
SADR: 23.33
DLR: 167.76

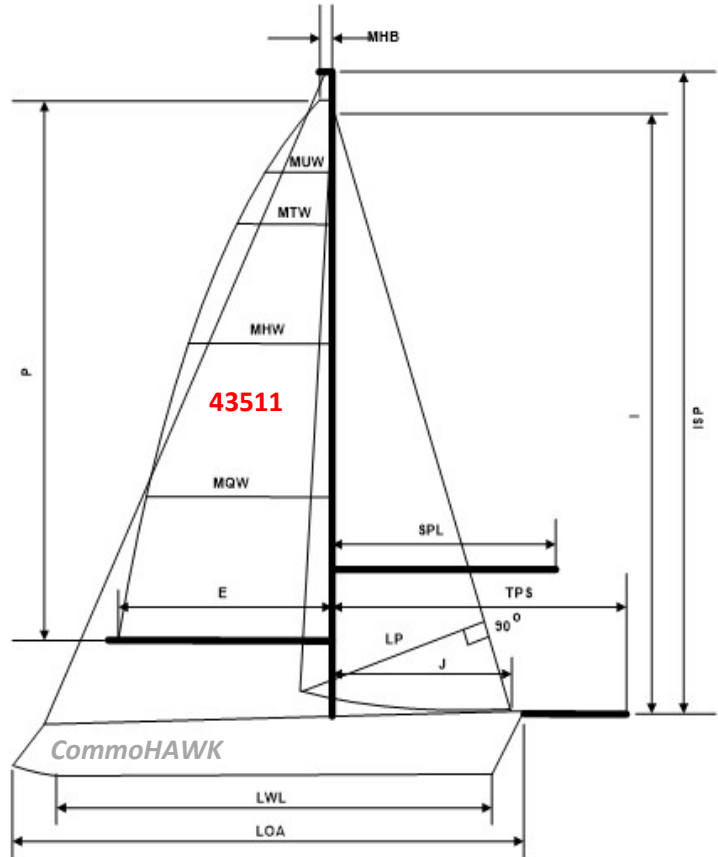

HANDICAP ADJUSTMENTS

Adjustments must be requested by the owner and are only made based on visual inspection and/or physical measurement by an authorized PHRF-SS measurer. Fixed Prop credit is for 3-bladed or more fixed prop in aperture or on exposed strut. Asymmetric credit is for an aftermarket sprit pole per Section 20 – Asymmetric Spinnakers. If Asymmetric Credit is given, a symmetrical spinnaker may not be flown at any event designated PHRF-SS. Codes appear in Section 8 - Handicap Adjustments of the PHRF-SS Rules & Bylaws.

Owner Signature: _____

My signature attests to the fact that all the information contained on this certificate is true and correct to the best of my knowledge and that I have not made any modifications to the boat which have not been reported to PHRF-SS.

Certificate Issue: 4/14/2024

Certificate Expires: 3/31/2025



SOUTH SHORE PHRF HANDICAP CERTIFICATE

PHRF-SS, LLC., PO Box 347021, Cleveland, OH 44134

<http://phrfss.org>

HCP (Handicap): 75 sec/nm
JAM (Jib & Main): 82 sec/nm
PPF (Perf Prediction Factor): 9.26
TCF (Time Correction Factor): 1.1104

CREW WEIGHT LIMIT: 2158 LBS.

YACHT NAME: GLASS PONY
DESIGN: FIRST (BENET) 35-2
OWNER: Jason Huffman
CERTIFICATE: **STND**
CLASSIFICATION: DSPL
SAIL NO: 25649
POWER: IB
CLUB: SSC

LOA: 35.60 FT.
LWL: 30.58 FT.
BEAM: 11.94 FT.
DRAFT: 7.55 FT.
DISPLACEMENT: 12125 LBS.
BALLAST: 3682 LBS.
SAIL AREA: 672 SQ. FT.
BASE SPIN: 917 SQ. FT
EST. FORESTAY: 49.03 FT.

I: 47.24 FT.
ISP: 47.24 FT.
J: 13.12 FT.
JSP/TPS: 14.73 FT.
P: 45.93 FT.
E: 15.75 FT.
SADR: 20.43
DLR: 189.29

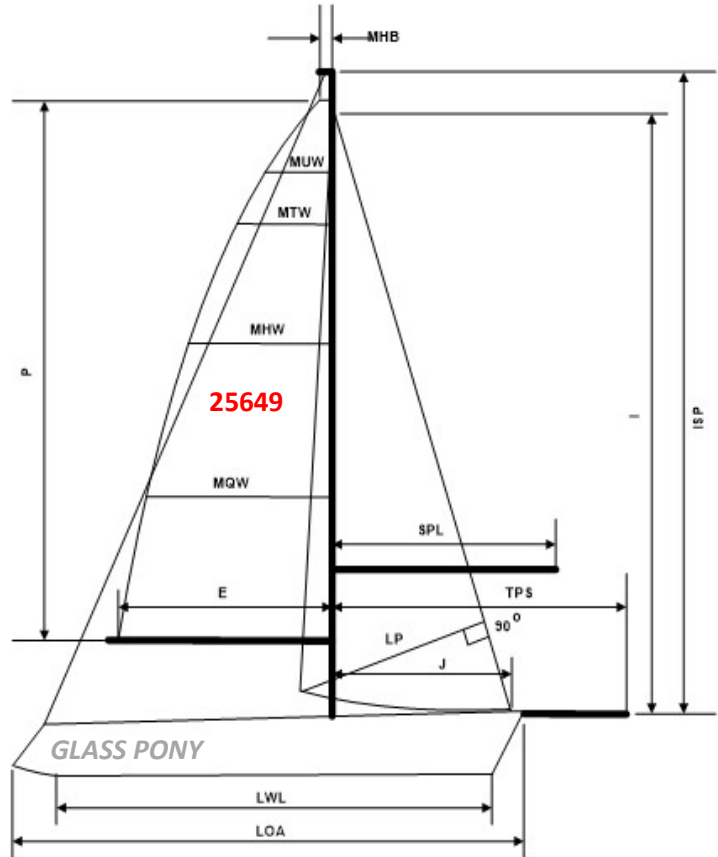

HANDICAP ADJUSTMENTS

Adjustments must be requested by the owner and are only made based on visual inspection and/or physical measurement by an authorized PHRF-SS measurer. Fixed Prop credit is for 3-bladed or more fixed prop in aperture or on exposed strut. Asymmetric credit is for an aftermarket sprit pole per Section 20 – Asymmetric Spinnakers. If Asymmetric Credit is given, a symmetrical spinnaker may not be flown at any event designated PHRF-SS. Codes appear in Section 8 - Handicap Adjustments of the PHRF-SS Rules & Bylaws.

Owner Signature: _____

My signature attests to the fact that all the information contained on this certificate is true and correct to the best of my knowledge and that I have not made any modifications to the boat which have not been reported to PHRF-SS.

Certificate Issue: 3/3/2024

Certificate Expires: 3/31/2025



SOUTH SHORE PHRF HANDICAP CERTIFICATE

PHRF-SS, LLC., PO Box 347021, Cleveland, OH 44134

<http://phrfss.org>

HCP (Handicap): 126 sec/nm
JAM (Jib & Main): 130 sec/nm
PPF (Perf Prediction Factor): 7.59
TCF (Time Correction Factor): 1.0056

CREW WEIGHT LIMIT: 1927 LBS.

YACHT NAME: ONE PASS
DESIGN: TARTAN 10 ODR
OWNER: Todd Imbler
CERTIFICATE: STND
CLASSIFICATION: DSPL
SAIL NO: 350
POWER: IB
CLUB: EWYC

LOA: 33.15 FT.
LWL: 27.00 FT.
BEAM: 9.25 FT.
DRAFT: 5.83 FT.
DISPLACEMENT: 7100 LBS.
BALLAST: 3340 LBS.
SAIL AREA: 488 SQ. FT.
BASE SPIN: 633 SQ. FT
EST. FORESTAY: 37.00 FT.

I: 35.00 FT.
ISP: 35.00 FT.
J: 12.00 FT.
JSP/TPS: 12.00 FT.
P: 40.30 FT.
E: 13.80 FT.
SADR: 21.21
DLR: 161.03

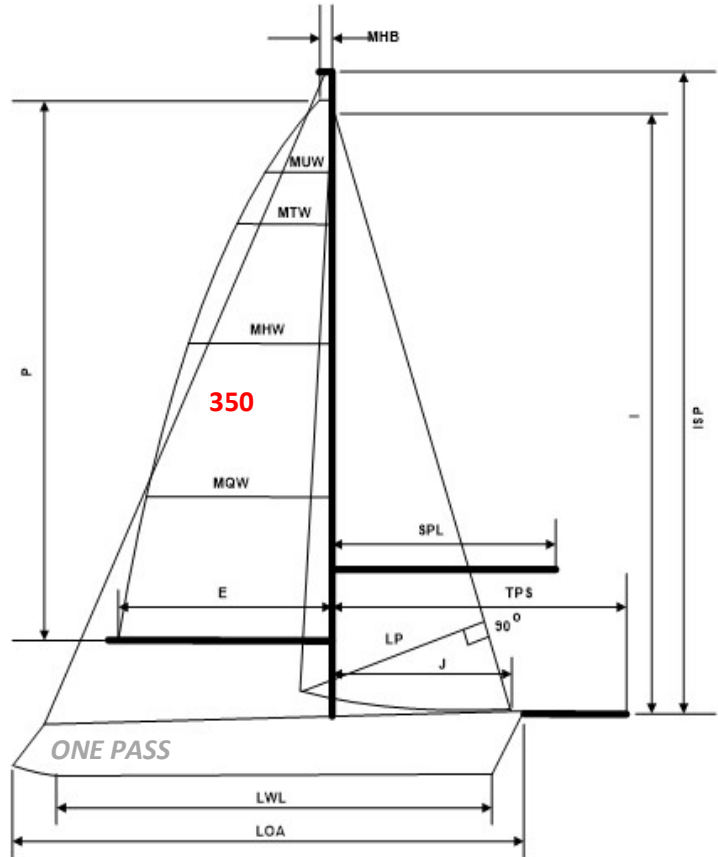

HANDICAP ADJUSTMENTS

Adjustments must be requested by the owner and are only made based on visual inspection and/or physical measurement by an authorized PHRF-SS measurer. Fixed Prop credit is for 3-bladed or more fixed prop in aperture or on exposed strut. Asymmetric credit is for an aftermarket sprit pole per Section 20 – Asymmetric Spinnakers. If Asymmetric Credit is given, a symmetrical spinnaker may not be flown at any event designated PHRF-SS. Codes appear in Section 8 - Handicap Adjustments of the PHRF-SS Rules & Bylaws.

Owner Signature: _____

My signature attests to the fact that all the information contained on this certificate is true and correct to the best of my knowledge and that I have not made any modifications to the boat which have not been reported to PHRF-SS.

Certificate Issue: 2/28/2024

Certificate Expires: 3/31/2025



SOUTH SHORE PHRF HANDICAP CERTIFICATE

PHRF-SS, LLC., PO Box 347021, Cleveland, OH 44134

<http://phrfss.org>

HCP (Handicap): 75 sec/nm
JAM (Jib & Main): 84 sec/nm
PPF (Perf Prediction Factor): 10.68
TCF (Time Correction Factor): 1.1104

CREW WEIGHT LIMIT: 2169 LBS.

YACHT NAME: BREAKAWAY3
DESIGN: BENET 36.7
OWNER: Mike Karns
CERTIFICATE: STND
CLASSIFICATION: DSPL
SAIL NO: 258
POWER: IB
CLUB: GRYC

LOA: 36.08 FT.
LWL: 30.25 FT.
BEAM: 11.33 FT.
DRAFT: 7.17 FT.
DISPLACEMENT: 12795 LBS.
BALLAST: 3748 LBS.
SAIL AREA: 658 SQ. FT.
BASE SPIN: 967 SQ. FT
EST. FORESTAY: 51.81 FT.

I: 46.40 FT.
ISP: 50.13 FT.
J: 13.10 FT.
JSP/TPS: 17.10 FT.
P: 45.40 FT.
E: 15.60 FT.
SADR: 19.31
DLR: 206.36

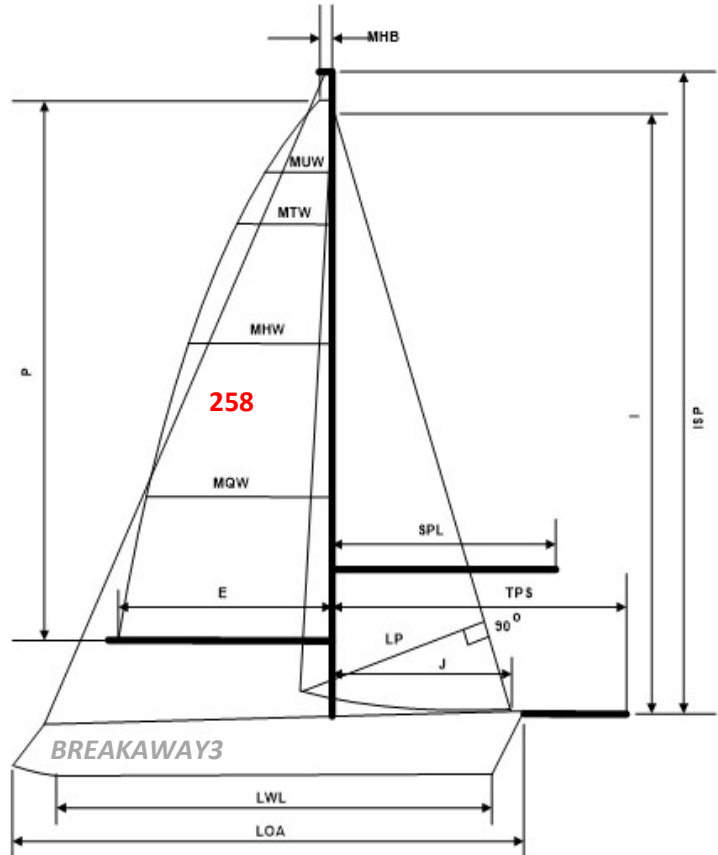

HANDICAP ADJUSTMENTS

+3 RFG / -6 ISP

Adjustments must be requested by the owner and are only made based on visual inspection and/or physical measurement by an authorized PHRF-SS measurer. Fixed Prop credit is for 3-bladed or more fixed prop in aperture or on exposed strut. Asymmetric credit is for an aftermarket sprit pole per Section 20 – Asymmetric Spinnakers. If Asymmetric Credit is given, a symmetrical spinnaker may not be flown at any event designated PHRF-SS. Codes appear in Section 8 - Handicap Adjustments of the PHRF-SS Rules & Bylaws.

Owner Signature: _____

My signature attests to the fact that all the information contained on this certificate is true and correct to the best of my knowledge and that I have not made any modifications to the boat which have not been reported to PHRF-SS.

Certificate Issue: 6/23/2024

Certificate Expires: 3/31/2025



SOUTH SHORE PHRF HANDICAP CERTIFICATE

PHRF-SS, LLC., PO Box 347021, Cleveland, OH 44134

<http://phrfss.org>

HCP (Handicap): 54 sec/nm
JAM (Jib & Main): 61 sec/nm
PPF (Perf Prediction Factor): 8.16
TCF (Time Correction Factor): 1.1601

CREW WEIGHT LIMIT: 2658 LBS.

YACHT NAME: UNCIVILIZED
DESIGN: DUFOUR 45e
OWNER: Russell Krock
CERTIFICATE: PRLM
CLASSIFICATION: DSPL
SAIL NO: 87
POWER: IB
CLUB: SSC

LOA: 44.62 FT.
LWL: 39.92 FT.
BEAM: 14.14 FT.
DRAFT: 6.38 FT.
DISPLACEMENT: 23671 LBS.
BALLAST: 7341 LBS.
SAIL AREA: 1044 SQ. FT.
BASE SPIN: 1452 SQ. FT
EST. FORESTAY: 61.93 FT.

I: 59.55 FT.
ISP: 59.71 FT.
J: 16.45 FT.
JSP/TPS: 17.43 FT.
P: 55.94 FT.
E: 19.82 FT.
SADR: 20.34
DLR: 166.11

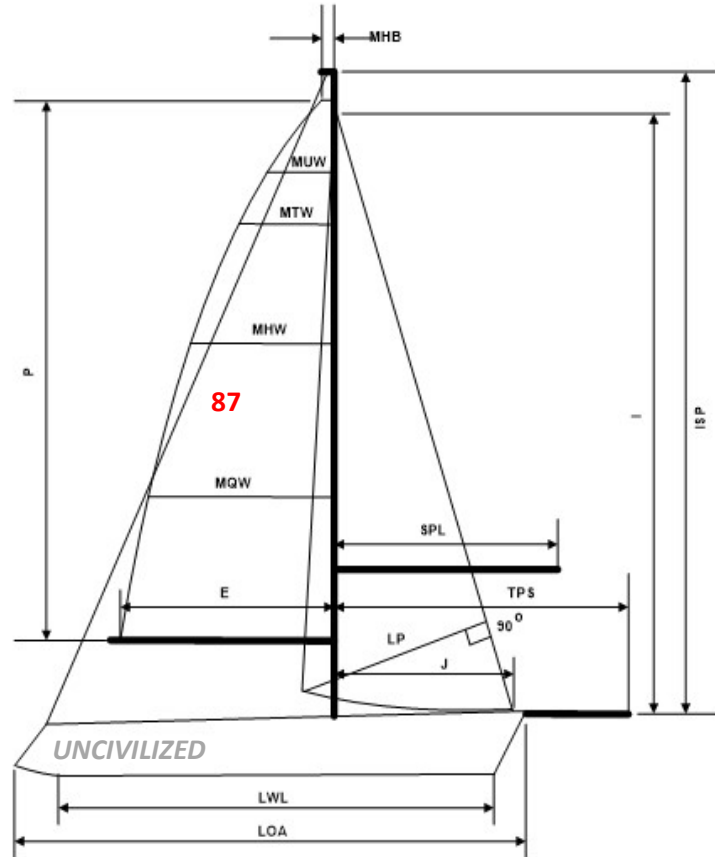

HANDICAP ADJUSTMENTS

Adjustments must be requested by the owner and are only made based on visual inspection and/or physical measurement by an authorized PHRF-SS measurer. Fixed Prop credit is for 3-bladed or more fixed prop in aperture or on exposed strut. Asymmetric credit is for an aftermarket sprit pole per Section 20 – Asymmetric Spinnakers. If Asymmetric Credit is given, a symmetrical spinnaker may not be flown at any event designated PHRF-SS. Codes appear in Section 8 - Handicap Adjustments of the PHRF-SS Rules & Bylaws.

Owner Signature: _____

My signature attests to the fact that all the information contained on this certificate is true and correct to the best of my knowledge and that I have not made any modifications to the boat which have not been reported to PHRF-SS.

Certificate Issue: 2/27/2024

Certificate Expires: 3/31/2025



SOUTH SHORE PHRF HANDICAP CERTIFICATE

PHRF-SS, LLC., PO Box 347021, Cleveland, OH 44134

<http://phrfss.org>

HCP (Handicap): 120 sec/nm
JAM (Jib & Main): 129 sec/nm
PPF (Perf Prediction Factor): 10.23
TCF (Time Correction Factor): 1.0168

CREW WEIGHT LIMIT: 1972 LBS.

YACHT NAME: BONAFIDE
DESIGN: J-34
OWNER: Dave Krotseng
CERTIFICATE: STND
CLASSIFICATION: DSPL
SAIL NO: 40370
POWER: IB
CLUB: EWYC

LOA: 34.00 FT.
LWL: 26.00 FT.
BEAM: 11.20 FT.
DRAFT: 6.20 FT.
DISPLACEMENT: 8100 LBS.
BALLAST: 3400 LBS.
SAIL AREA: 505 SQ. FT.
BASE SPIN: 822 SQ. FT
EST. FORESTAY: 45.77 FT.

I: 44.00 FT.
ISP: 44.00 FT.
J: 12.60 FT.
JSP/TPS: 12.60 FT.
P: 38.00 FT.
E: 12.00 FT.
SADR: 20.11
DLR: 205.74

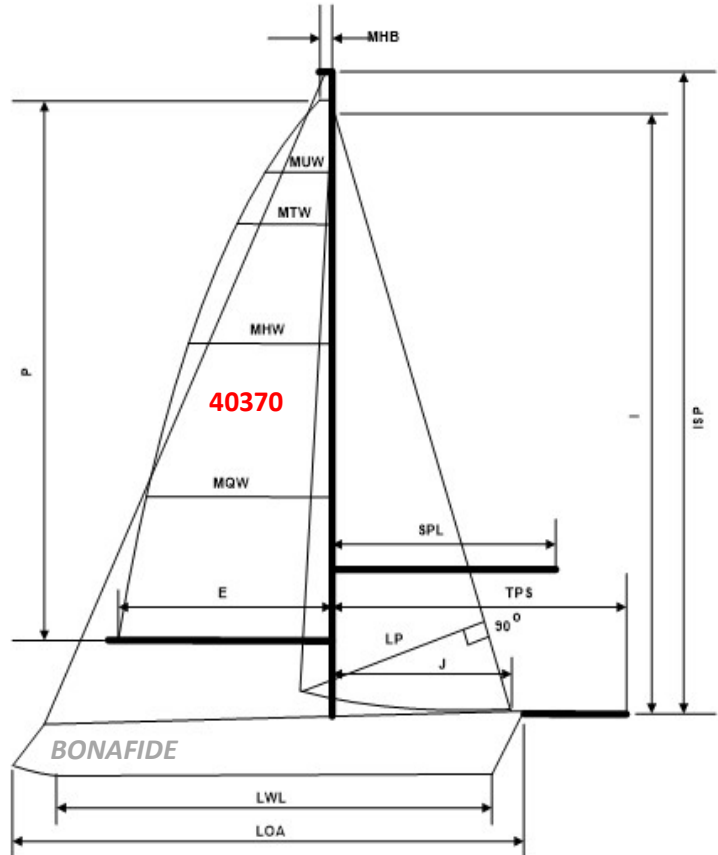

HANDICAP ADJUSTMENTS

Adjustments must be requested by the owner and are only made based on visual inspection and/or physical measurement by an authorized PHRF-SS measurer. Fixed Prop credit is for 3-bladed or more fixed prop in aperture or on exposed strut. Asymmetric credit is for an aftermarket sprit pole per Section 20 – Asymmetric Spinnakers. If Asymmetric Credit is given, a symmetrical spinnaker may not be flown at any event designated PHRF-SS. Codes appear in Section 8 - Handicap Adjustments of the PHRF-SS Rules & Bylaws.

Owner Signature: _____

My signature attests to the fact that all the information contained on this certificate is true and correct to the best of my knowledge and that I have not made any modifications to the boat which have not been reported to PHRF-SS.

Certificate Issue: 5/12/2024

Certificate Expires: 3/31/2025



SOUTH SHORE PHRF HANDICAP CERTIFICATE

PHRF-SS, LLC., PO Box 347021, Cleveland, OH 44134

<http://phrfss.org>

HCP (Handicap): -15 sec/nm
JAM (Jib & Main): -5 sec/nm
PPF (Perf Prediction Factor): 3.69
TCF (Time Correction Factor): 1.3606

CREW WEIGHT LIMIT: 2556 LBS.

YACHT NAME: EXODUS
DESIGN: FARR 40 MH
OWNER: Frank Kups
CERTIFICATE: **STND**
CLASSIFICATION: HPRF
SAIL NO: 40036
POWER: IB
CLUB: LYC

LOA: 40.72 FT.
LWL: 35.27 FT.
BEAM: 13.22 FT.
DRAFT: 8.53 FT.
DISPLACEMENT: 10902 LBS.
BALLAST: 4960 LBS.
SAIL AREA: 921 SQ. FT.
BASE SPIN: 1363 SQ. FT.
EST. FORESTAY: 61.90 FT.

I: 53.15 FT.
ISP: 59.94 FT.
J: 15.45 FT.
JSP/TPS: 23.60 FT.
P: 55.04 FT.
E: 18.54 FT.
SADR: 30.07
DLR: 110.93

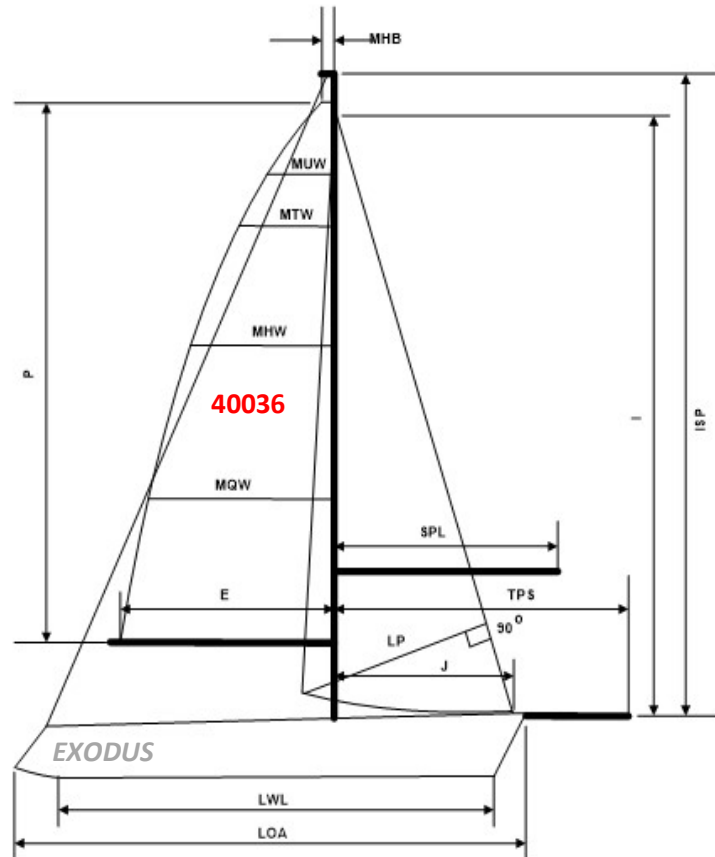

HANDICAP ADJUSTMENTS

-3 SQTm / -3ASYM

Adjustments must be requested by the owner and are only made based on visual inspection and/or physical measurement by an authorized PHRF-SS measurer. Fixed Prop credit is for 3-bladed or more fixed prop in aperture or on exposed strut. Asymmetric credit is for an aftermarket sprit pole per Section 20 – Asymmetric Spinnakers. If Asymmetric Credit is given, a symmetrical spinnaker may not be flown at any event designated PHRF-SS. Codes appear in Section 8 - Handicap Adjustments of the PHRF-SS Rules & Bylaws.

Owner Signature: _____

My signature attests to the fact that all the information contained on this certificate is true and correct to the best of my knowledge and that I have not made any modifications to the boat which have not been reported to PHRF-SS.

Certificate Issue: 6/18/2024

Certificate Expires: 3/31/2025



SOUTH SHORE PHRF HANDICAP CERTIFICATE

PHRF-SS, LLC., PO Box 347021, Cleveland, OH 44134

<http://phrfss.org>

HCP (Handicap): 120 sec/nm
JAM (Jib & Main): 129 sec/nm
PPF (Perf Prediction Factor): 10.23
TCF (Time Correction Factor): 1.0168

CREW WEIGHT LIMIT: 1972 LBS.

YACHT NAME: KNEE DEEP
DESIGN: J-34
OWNER: Brett Langolf
CERTIFICATE: STND
CLASSIFICATION: DSPL
SAIL NO: 25006
POWER: IB
CLUB: SSC

LOA: 34.00 FT.
LWL: 26.00 FT.
BEAM: 11.20 FT.
DRAFT: 6.20 FT.
DISPLACEMENT: 8100 LBS.
BALLAST: 3400 LBS.
SAIL AREA: 505 SQ. FT.
BASE SPIN: 822 SQ. FT
EST. FORESTAY: 45.77 FT.

I: 44.00 FT.
ISP: 44.00 FT.
J: 12.60 FT.
JSP/TPS: 12.60 FT.
P: 38.00 FT.
E: 12.00 FT.
SADR: 20.11
DLR: 205.74

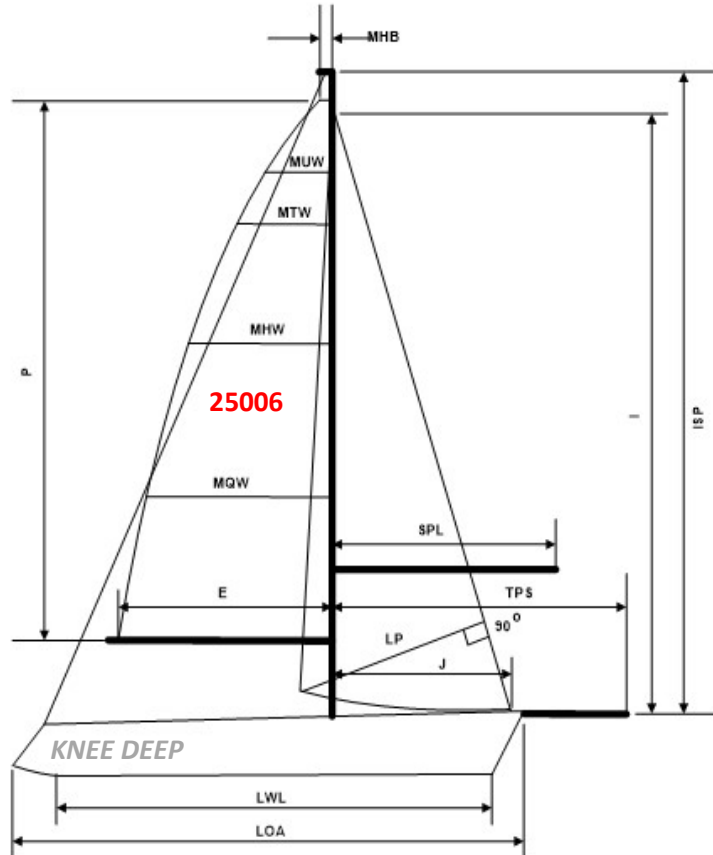

HANDICAP ADJUSTMENTS

100% ASYM decalred

Adjustments must be requested by the owner and are only made based on visual inspection and/or physical measurement by an authorized PHRF-SS measurer. Fixed Prop credit is for 3-bladed or more fixed prop in aperture or on exposed strut. Asymmetric credit is for an aftermarket sprit pole per Section 20 – Asymmetric Spinnakers. If Asymmetric Credit is given, a symmetrical spinnaker may not be flown at any event designated PHRF-SS. Codes appear in Section 8 - Handicap Adjustments of the PHRF-SS Rules & Bylaws.

Owner Signature: _____

My signature attests to the fact that all the information contained on this certificate is true and correct to the best of my knowledge and that I have not made any modifications to the boat which have not been reported to PHRF-SS.

Certificate Issue: 5/27/2024

Certificate Expires: 3/31/2025



SOUTH SHORE PHRF HANDICAP CERTIFICATE

PHRF-SS, LLC., PO Box 347021, Cleveland, OH 44134

<http://phrfss.org>

HCP (Handicap): 228 sec/nm
JAM (Jib & Main): 0 sec/nm
PPF (Perf Prediction Factor): 8.33
TCF (Time Correction Factor): 0.8459

CREW WEIGHT LIMIT: 1325 LBS.

YACHT NAME: SISU
DESIGN: SANTANA 2023A TM
OWNER: Jeff Lehtinen
CERTIFICATE: **STND**
CLASSIFICATION: DSPL
SAIL NO: 2023
POWER: OB
CLUB: GRSC

LOA: 23.25 FT.
LWL: 20.62 FT.
BEAM: 8.50 FT.
DRAFT: 5.33 FT.
DISPLACEMENT: 2880 LBS.
BALLAST: 1300 LBS.
SAIL AREA: 222 SQ. FT.
BASE SPIN: 308 SQ. FT
EST. FORESTAY: 24.70 FT.

I: 23.10 FT.
ISP: 23.10 FT.
J: 8.75 FT.
JSP/TPS: 8.75 FT.
P: 24.20 FT.
E: 10.00 FT.
SADR: 17.60
DLR: 146.65

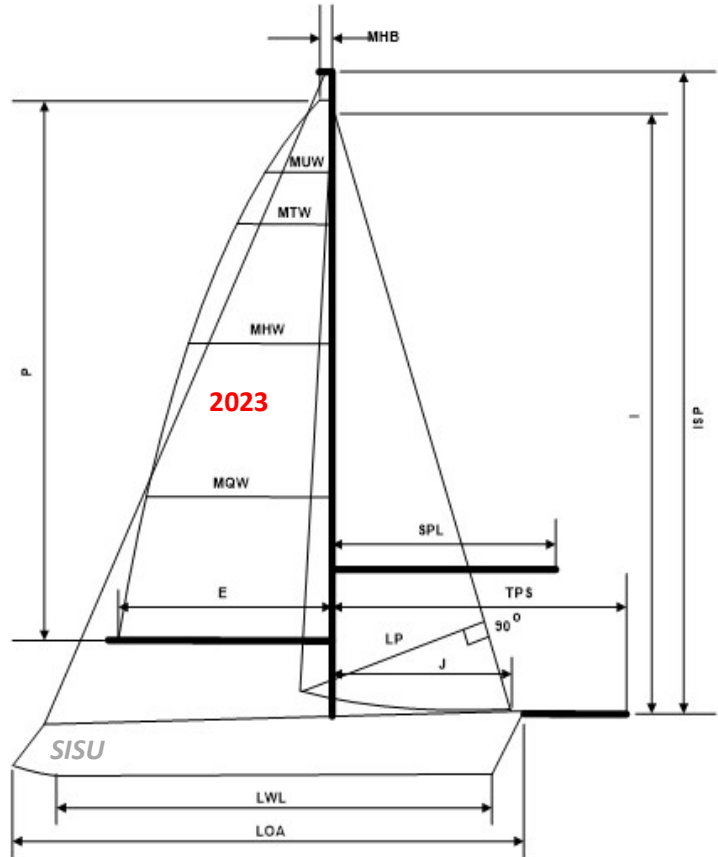

HANDICAP ADJUSTMENTS

Water ballast must be kept on-board

Adjustments must be requested by the owner and are only made based on visual inspection and/or physical measurement by an authorized PHRF-SS measurer. Fixed Prop credit is for 3-bladed or more fixed prop in aperture or on exposed strut. Asymmetric credit is for an aftermarket sprit pole per Section 20 – Asymmetric Spinnakers. If Asymmetric Credit is given, a symmetrical spinnaker may not be flown at any event designated PHRF-SS. Codes appear in Section 8 - Handicap Adjustments of the PHRF-SS Rules & Bylaws.

Owner Signature: _____

My signature attests to the fact that all the information contained on this certificate is true and correct to the best of my knowledge and that I have not made any modifications to the boat which have not been reported to PHRF-SS.

Certificate Issue: 3/24/2024

Certificate Expires: 3/31/2025



SOUTH SHORE PHRF HANDICAP CERTIFICATE

PHRF-SS, LLC., PO Box 347021, Cleveland, OH 44134

<http://phrfss.org>

HCP (Handicap): 69 sec/nm
JAM (Jib & Main): 79 sec/nm
PPF (Perf Prediction Factor): 6.27
TCF (Time Correction Factor): 1.1241

CREW WEIGHT LIMIT: 2172 LBS.

YACHT NAME: WAVELENGTH
DESIGN: THOMAS 35
OWNER: Al Linne
CERTIFICATE: STND
CLASSIFICATION: DSPL
SAIL NO: 60812
POWER: IB
CLUB: EWYC

LOA: 35.42 FT.
LWL: 30.50 FT.
BEAM: 11.50 FT.
DRAFT: 6.83 FT.
DISPLACEMENT: 9800 LBS.
BALLAST: 4450 LBS.
SAIL AREA: 702 SQ. FT.
BASE SPIN: 1017 SQ. FT.
EST. FORESTAY: 50.07 FT.

I: 48.00 FT.
ISP: 48.00 FT.
J: 14.25 FT.
JSP/TPS: 18.73 FT.
P: 48.00 FT.
E: 15.00 FT.
SADR: 24.61
DLR: 154.20

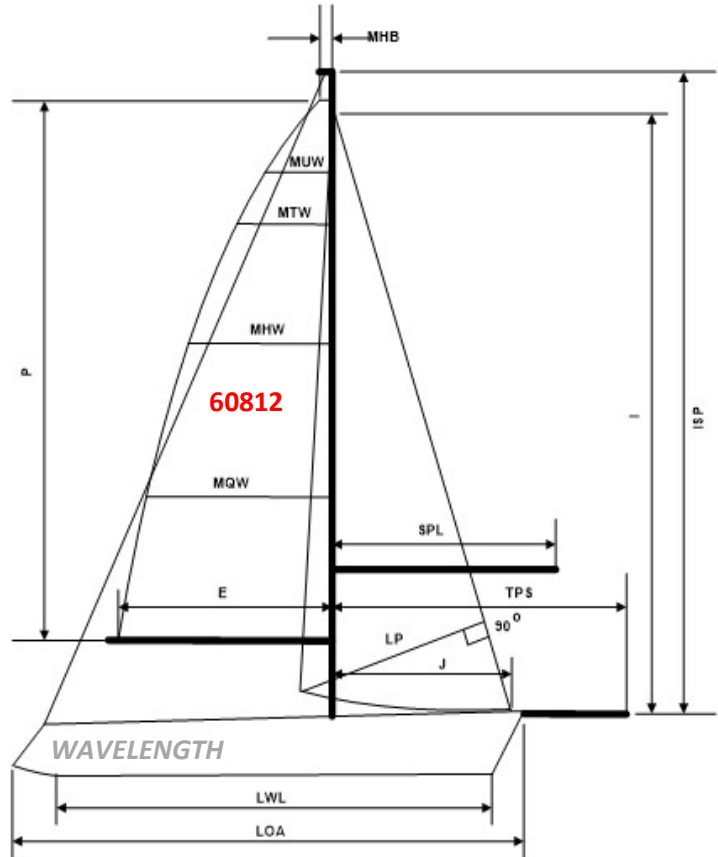

HANDICAP ADJUSTMENTS

-3CM / 133% ASYM /FRAC

Adjustments must be requested by the owner and are only made based on visual inspection and/or physical measurement by an authorized PHRF-SS measurer. Fixed Prop credit is for 3-bladed or more fixed prop in aperture or on exposed strut. Asymmetric credit is for an aftermarket sprit pole per Section 20 – Asymmetric Spinnakers. If Asymmetric Credit is given, a symmetrical spinnaker may not be flown at any event designated PHRF-SS. Codes appear in Section 8 - Handicap Adjustments of the PHRF-SS Rules & Bylaws.

Owner Signature: _____

My signature attests to the fact that all the information contained on this certificate is true and correct to the best of my knowledge and that I have not made any modifications to the boat which have not been reported to PHRF-SS.

Certificate Issue: 2/27/2024

Certificate Expires: 3/31/2025



SOUTH SHORE PHRF HANDICAP CERTIFICATE

PHRF-SS, LLC., PO Box 347021, Cleveland, OH 44134

<http://phrfss.org>

HCP (Handicap): 172 sec/nm
JAM (Jib & Main): 180 sec/nm
PPF (Perf Prediction Factor): 14.68
TCF (Time Correction Factor): 0.9267

CREW WEIGHT LIMIT: 1845 LBS.

YACHT NAME: LONGSHOT
DESIGN: CAT 320 WK
OWNER: David Long
CERTIFICATE: STND
CLASSIFICATION: DSPL
SAIL NO: 44
POWER: IB
CLUB: FCYC

LOA: 32.50 FT.
LWL: 28.00 FT.
BEAM: 11.75 FT.
DRAFT: 4.30 FT.
DISPLACEMENT: 11700 LBS.
BALLAST: 4400 LBS.
SAIL AREA: 520 SQ. FT.
BASE SPIN: 796 SQ. FT
EST. FORESTAY: 45.29 FT.

I: 43.58 FT.
ISP: 43.58 FT.
J: 12.33 FT.
JSP/TPS: 12.33 FT.
P: 38.00 FT.
E: 13.25 FT.
SADR: 16.21
DLR: 237.94

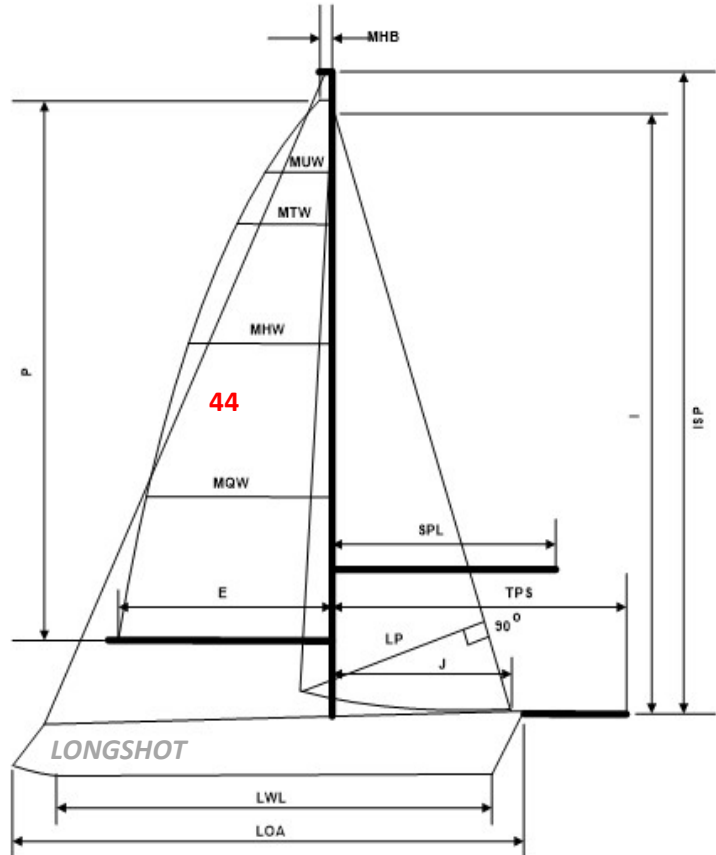

HANDICAP ADJUSTMENTS

+3(2BX); +6RFG

Adjustments must be requested by the owner and are only made based on visual inspection and/or physical measurement by an authorized PHRF-SS measurer. Fixed Prop credit is for 3-bladed or more fixed prop in aperture or on exposed strut. Asymmetric credit is for an aftermarket sprit pole per Section 20 – Asymmetric Spinnakers. If Asymmetric Credit is given, a symmetrical spinnaker may not be flown at any event designated PHRF-SS. Codes appear in Section 8 - Handicap Adjustments of the PHRF-SS Rules & Bylaws.

Owner Signature: _____

My signature attests to the fact that all the information contained on this certificate is true and correct to the best of my knowledge and that I have not made any modifications to the boat which have not been reported to PHRF-SS.

Certificate Issue: 3/13/2024

Certificate Expires: 3/31/2025



SOUTH SHORE PHRF HANDICAP CERTIFICATE

PHRF-SS, LLC., PO Box 347021, Cleveland, OH 44134

<http://phrfss.org>

HCP (Handicap): 126 sec/nm
JAM (Jib & Main): 133 sec/nm
PPF (Perf Prediction Factor): 6.65
TCF (Time Correction Factor): 1.0056

CREW WEIGHT LIMIT: 1909 LBS.

YACHT NAME: DAGNABBOTT
DESIGN: ABBOTT 33
OWNER: Jim Mackey
CERTIFICATE: STND
CLASSIFICATION: DSPL
SAIL NO: 136
POWER: IB
CLUB: EWYC

LOA: 33.29 FT.
LWL: 26.92 FT.
BEAM: 8.21 FT.
DRAFT: 5.42 FT.
DISPLACEMENT: 6057 LBS.
BALLAST: 3304 LBS.
SAIL AREA: 432 SQ. FT.
BASE SPIN: 619 SQ. FT
EST. FORESTAY: 37.79 FT.

I: 36.00 FT.
ISP: 36.00 FT.
J: 11.50 FT.
JSP/TPS: 11.50 FT.
P: 38.55 FT.
E: 11.65 FT.
SADR: 20.84
DLR: 138.61

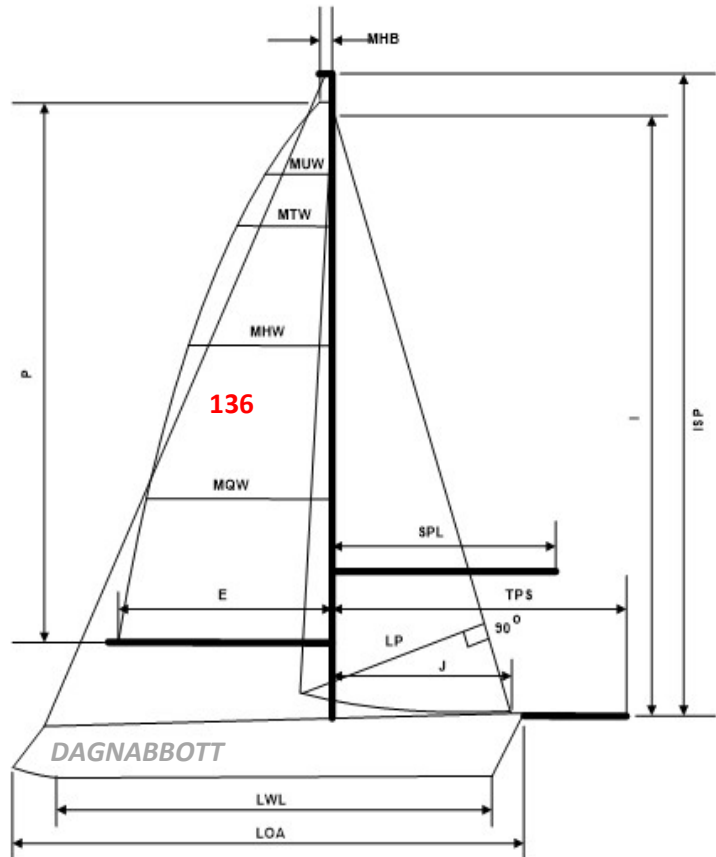

HANDICAP ADJUSTMENTS

Adjustments must be requested by the owner and are only made based on visual inspection and/or physical measurement by an authorized PHRF-SS measurer. Fixed Prop credit is for 3-bladed or more fixed prop in aperture or on exposed strut. Asymmetric credit is for an aftermarket sprit pole per Section 20 – Asymmetric Spinnakers. If Asymmetric Credit is given, a symmetrical spinnaker may not be flown at any event designated PHRF-SS. Codes appear in Section 8 - Handicap Adjustments of the PHRF-SS Rules & Bylaws.

Owner Signature: _____

My signature attests to the fact that all the information contained on this certificate is true and correct to the best of my knowledge and that I have not made any modifications to the boat which have not been reported to PHRF-SS.

Certificate Issue: 5/26/2024

Certificate Expires: 3/31/2025



SOUTH SHORE PHRF HANDICAP CERTIFICATE

PHRF-SS, LLC., PO Box 347021, Cleveland, OH 44134

<http://phrfss.org>

HCP (Handicap): 15 sec/nm
JAM (Jib & Main): 25 sec/nm
PPF (Perf Prediction Factor): 1.98
TCF (Time Correction Factor): 1.2655

CREW WEIGHT LIMIT: 2062 LBS.

YACHT NAME: FLAT STANLEY RACING
DESIGN: MELGES 32 ODR
OWNER: Terry McSweeney
CERTIFICATE: **ODR**
CLASSIFICATION: HPRF
SAIL NO: 1215
POWER: IB
CLUB: EWYC

LOA: 31.83 FT.
LWL: 28.50 FT.
BEAM: 9.83 FT.
DRAFT: 7.00 FT.
DISPLACEMENT: 3774 LBS.
BALLAST: 1570 LBS.
SAIL AREA: 554 SQ. FT.
BASE SPIN: 760 SQ. FT
EST. FORESTAY: 49.40 FT.

I: 39.90 FT.
ISP: 48.20 FT.
J: 10.80 FT.
JSP/TPS: 19.43 FT.
P: 44.00 FT.
E: 15.40 FT.
SADR: 36.68
DLR: 72.78

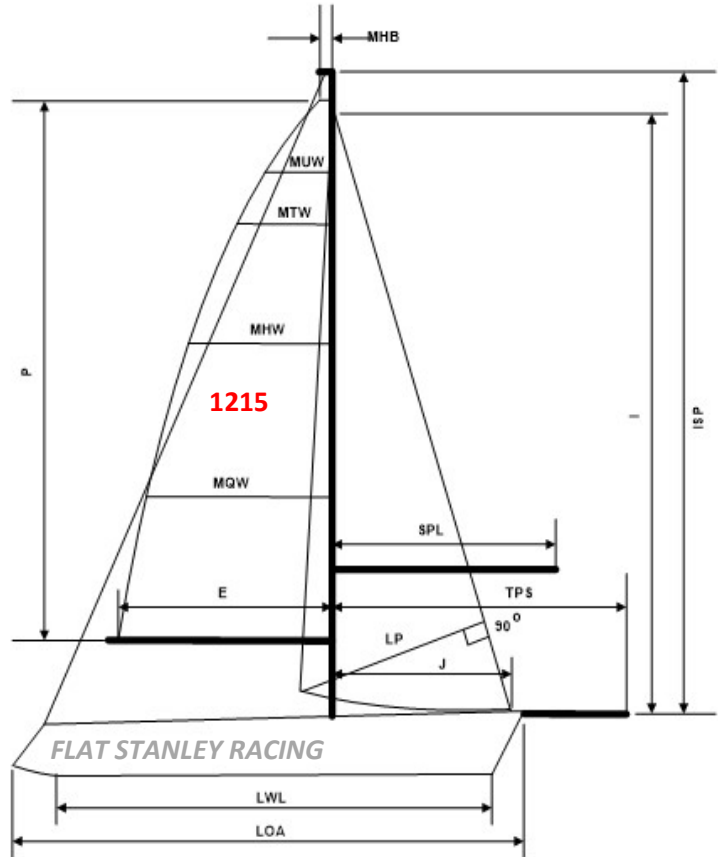

HANDICAP ADJUSTMENTS

104% JIB / 103SQM - 121SQM

Adjustments must be requested by the owner and are only made based on visual inspection and/or physical measurement by an authorized PHRF-SS measurer. Fixed Prop credit is for 3-bladed or more fixed prop in aperture or on exposed strut. Asymmetric credit is for an aftermarket sprit pole per Section 20 – Asymmetric Spinnakers. If Asymmetric Credit is given, a symmetrical spinnaker may not be flown at any event designated PHRF-SS. Codes appear in Section 8 - Handicap Adjustments of the PHRF-SS Rules & Bylaws.

Owner Signature: _____

My signature attests to the fact that all the information contained on this certificate is true and correct to the best of my knowledge and that I have not made any modifications to the boat which have not been reported to PHRF-SS.

Certificate Issue: 6/13/2024

Certificate Expires: 3/31/2025



SOUTH SHORE PHRF HANDICAP CERTIFICATE

PHRF-SS, LLC., PO Box 347021, Cleveland, OH 44134

<http://phrfss.org>

HCP (Handicap): 162 sec/nm
JAM (Jib & Main): 168 sec/nm
PPF (Perf Prediction Factor): 10.15
TCF (Time Correction Factor): 0.9427

CREW WEIGHT LIMIT: 1905 LBS.

YACHT NAME: AMIGA
DESIGN: TARTAN 33
OWNER: David Mills
CERTIFICATE: STND
CLASSIFICATION: DSPL
SAIL NO: 30556
POWER: IB
CLUB: EWYC

LOA: 33.67 FT.
LWL: 28.83 FT.
BEAM: 10.96 FT.
DRAFT: 4.56 FT.
DISPLACEMENT: 10000 LBS.
BALLAST: 4400 LBS.
SAIL AREA: 531 SQ. FT.
BASE SPIN: 729 SQ. FT
EST. FORESTAY: 40.95 FT.

I: 39.00 FT.
ISP: 39.00 FT.
J: 12.50 FT.
JSP/TPS: 12.50 FT.
P: 41.75 FT.
E: 13.75 FT.
SADR: 18.36
DLR: 186.30

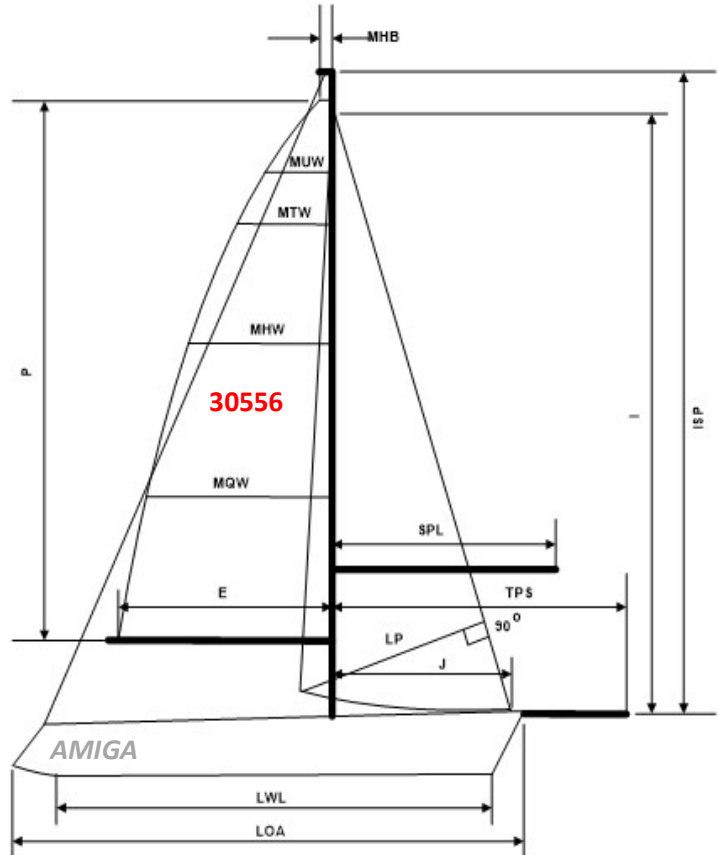

HANDICAP ADJUSTMENTS

Adjustments must be requested by the owner and are only made based on visual inspection and/or physical measurement by an authorized PHRF-SS measurer. Fixed Prop credit is for 3-bladed or more fixed prop in aperture or on exposed strut. Asymmetric credit is for an aftermarket sprit pole per Section 20 – Asymmetric Spinnakers. If Asymmetric Credit is given, a symmetrical spinnaker may not be flown at any event designated PHRF-SS. Codes appear in Section 8 - Handicap Adjustments of the PHRF-SS Rules & Bylaws.

Owner Signature: _____

My signature attests to the fact that all the information contained on this certificate is true and correct to the best of my knowledge and that I have not made any modifications to the boat which have not been reported to PHRF-SS.

Certificate Issue: 3/9/2024

Certificate Expires: 3/31/2025



SOUTH SHORE PHRF HANDICAP CERTIFICATE

PHRF-SS, LLC., PO Box 347021, Cleveland, OH 44134

<http://phrfss.org>

HCP (Handicap): 90 sec/nm
JAM (Jib & Main): 100 sec/nm
PPF (Perf Prediction Factor): 6.74
TCF (Time Correction Factor): 1.0773

CREW WEIGHT LIMIT: 2061 LBS.

YACHT NAME: BREEZIN BAYOU
DESIGN: J-105 ODR
OWNER: Stephen Mitcham
CERTIFICATE: ODR
CLASSIFICATION: DSPL
SAIL NO: 93
POWER: IB
CLUB: FCYC

LOA: 34.50 FT.
LWL: 29.50 FT.
BEAM: 11.00 FT.
DRAFT: 6.50 FT.
DISPLACEMENT: 8575 LBS.
BALLAST: 3400 LBS.
SAIL AREA: 577 SQ. FT.
BASE SPIN: 851 SQ. FT
EST. FORESTAY: 44.21 FT.

I: 40.60 FT.
ISP: 42.10 FT.
J: 13.50 FT.
JSP/TPS: 19.00 FT.
P: 41.50 FT.
E: 14.60 FT.
SADR: 22.11
DLR: 149.11

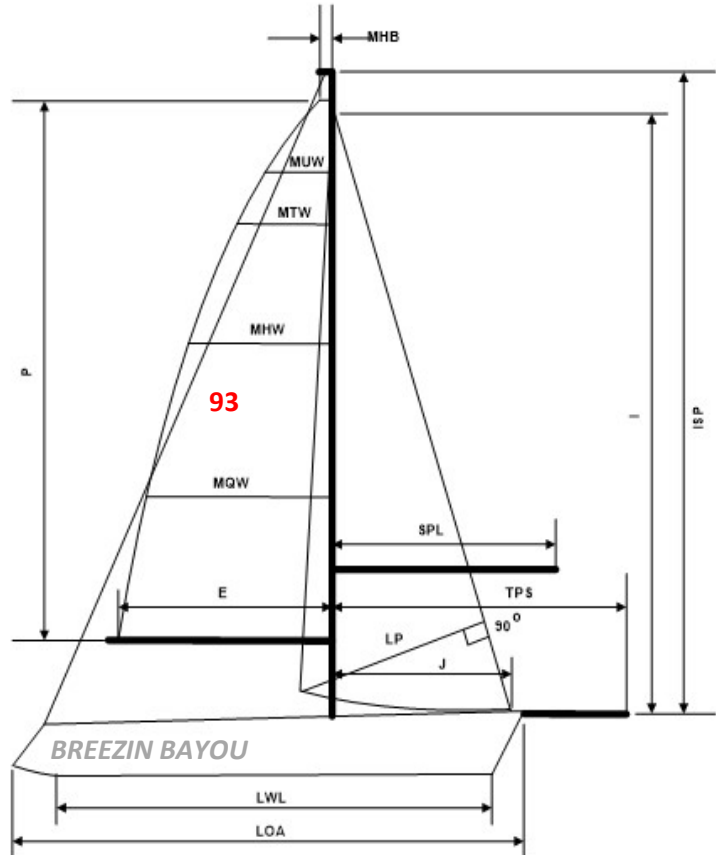

HANDICAP ADJUSTMENTS

ODR 102% JIB/89 SQM ASYM

Adjustments must be requested by the owner and are only made based on visual inspection and/or physical measurement by an authorized PHRF-SS measurer. Fixed Prop credit is for 3-bladed or more fixed prop in aperture or on exposed strut. Asymmetric credit is for an aftermarket sprit pole per Section 20 – Asymmetric Spinnakers. If Asymmetric Credit is given, a symmetrical spinnaker may not be flown at any event designated PHRF-SS. Codes appear in Section 8 - Handicap Adjustments of the PHRF-SS Rules & Bylaws.

Owner Signature: _____

My signature attests to the fact that all the information contained on this certificate is true and correct to the best of my knowledge and that I have not made any modifications to the boat which have not been reported to PHRF-SS.

Certificate Issue: 5/19/2024

Certificate Expires: 3/31/2025



SOUTH SHORE PHRF HANDICAP CERTIFICATE

PHRF-SS, LLC., PO Box 347021, Cleveland, OH 44134

<http://phrfss.org>

HCP (Handicap): 90 sec/nm
JAM (Jib & Main): 100 sec/nm
PPF (Perf Prediction Factor): 6.74
TCF (Time Correction Factor): 1.0773

CREW WEIGHT LIMIT: 2061 LBS.

YACHT NAME: UNBRIDLED
DESIGN: J-105 ODR
OWNER: Rob Mock
CERTIFICATE: ODR
CLASSIFICATION: DSPL
SAIL NO: 52000
POWER: IB
CLUB: EWYC

LOA: 34.50 FT.
LWL: 29.50 FT.
BEAM: 11.00 FT.
DRAFT: 6.50 FT.
DISPLACEMENT: 8575 LBS.
BALLAST: 3400 LBS.
SAIL AREA: 577 SQ. FT.
BASE SPIN: 851 SQ. FT
EST. FORESTAY: 44.21 FT.

I: 40.60 FT.
ISP: 42.10 FT.
J: 13.50 FT.
JSP/TPS: 19.00 FT.
P: 41.50 FT.
E: 14.60 FT.
SADR: 22.11
DLR: 149.11

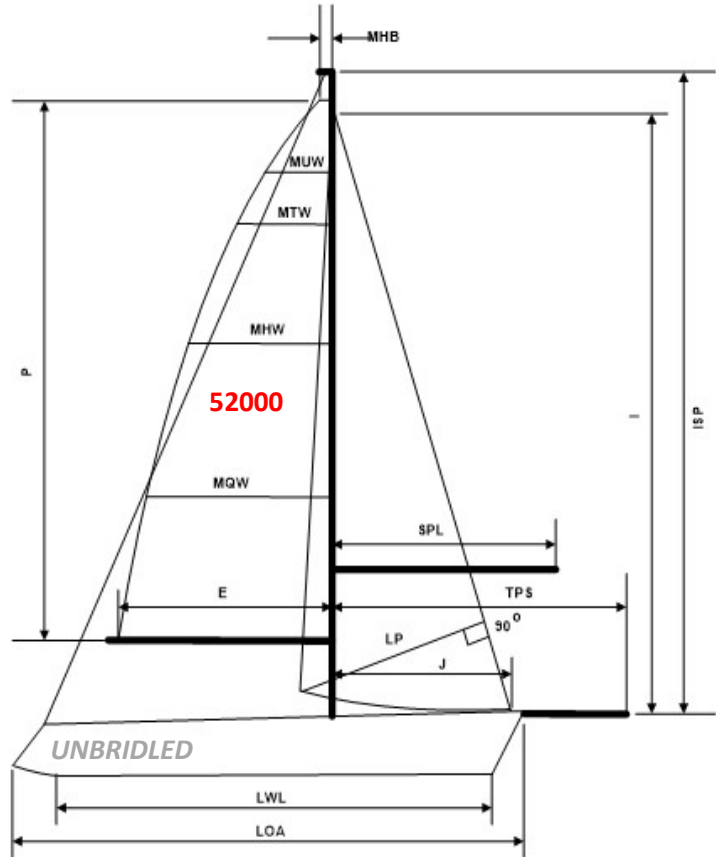

HANDICAP ADJUSTMENTS

ODR 102% JIB/89 SQM ASYM

Adjustments must be requested by the owner and are only made based on visual inspection and/or physical measurement by an authorized PHRF-SS measurer. Fixed Prop credit is for 3-bladed or more fixed prop in aperture or on exposed strut. Asymmetric credit is for an aftermarket sprit pole per Section 20 – Asymmetric Spinnakers. If Asymmetric Credit is given, a symmetrical spinnaker may not be flown at any event designated PHRF-SS. Codes appear in Section 8 - Handicap Adjustments of the PHRF-SS Rules & Bylaws.

Owner Signature: _____

My signature attests to the fact that all the information contained on this certificate is true and correct to the best of my knowledge and that I have not made any modifications to the boat which have not been reported to PHRF-SS.

Certificate Issue: 4/14/2024

Certificate Expires: 3/31/2025



SOUTH SHORE PHRF HANDICAP CERTIFICATE

PHRF-SS, LLC., PO Box 347021, Cleveland, OH 44134

<http://phrfss.org>

HCP (Handicap): 162 sec/nm
JAM (Jib & Main): 170 sec/nm
PPF (Perf Prediction Factor): 8.97
TCF (Time Correction Factor): 0.9427

CREW WEIGHT LIMIT: 1903 LBS.

YACHT NAME: BACCHANAL
DESIGN: OCEANIS (BENET) 331 SD
OWNER: Rebecca Nelson
CERTIFICATE: **STND**
CLASSIFICATION: DSPL
SAIL NO: 61409
POWER: IB
CLUB: EWYC

LOA: 33.96 FT.
LWL: 30.51 FT.
BEAM: 11.22 FT.
DRAFT: 5.25 FT.
DISPLACEMENT: 9920 LBS.
BALLAST: 3086 LBS.
SAIL AREA: 500 SQ. FT.
BASE SPIN: 754 SQ. FT
EST. FORESTAY: 42.89 FT.

I: 41.08 FT.
ISP: 41.08 FT.
J: 12.34 FT.
JSP/TPS: 12.34 FT.
P: 34.58 FT.
E: 14.27 FT.
SADR: 17.39
DLR: 155.93

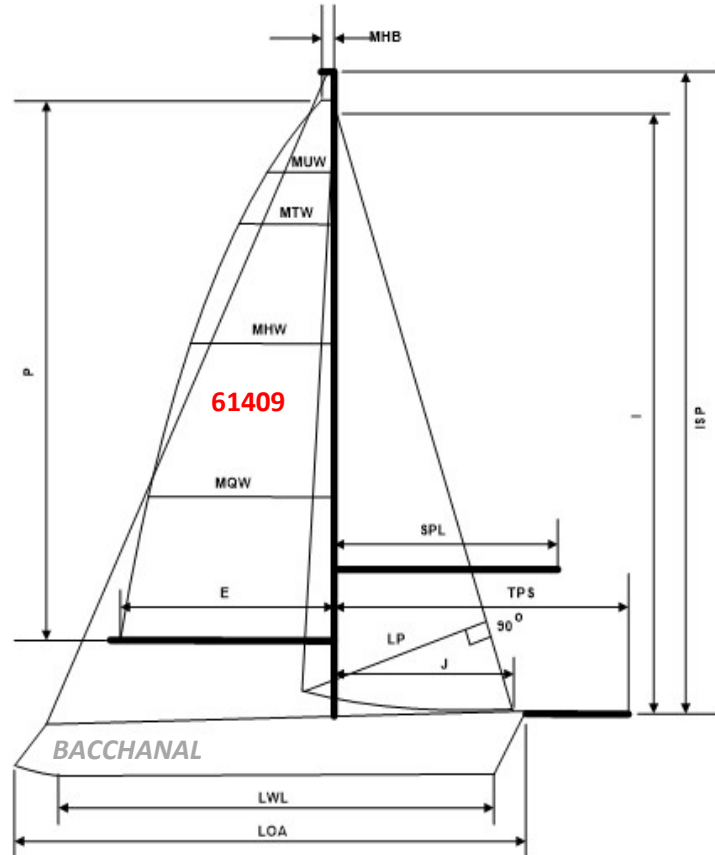

HANDICAP ADJUSTMENTS

+3RFG / +6RFM

Adjustments must be requested by the owner and are only made based on visual inspection and/or physical measurement by an authorized PHRF-SS measurer. Fixed Prop credit is for 3-bladed or more fixed prop in aperture or on exposed strut. Asymmetric credit is for an aftermarket sprit pole per Section 20 – Asymmetric Spinnakers. If Asymmetric Credit is given, a symmetrical spinnaker may not be flown at any event designated PHRF-SS. Codes appear in Section 8 - Handicap Adjustments of the PHRF-SS Rules & Bylaws.

Owner Signature: _____

My signature attests to the fact that all the information contained on this certificate is true and correct to the best of my knowledge and that I have not made any modifications to the boat which have not been reported to PHRF-SS.

Certificate Issue: 3/31/2024

Certificate Expires: 3/31/2025



SOUTH SHORE PHRF HANDICAP CERTIFICATE

PHRF-SS, LLC., PO Box 347021, Cleveland, OH 44134

<http://phrfss.org>

HCP (Handicap): 117 sec/nm
JAM (Jib & Main): 128 sec/nm
PPF (Perf Prediction Factor): 7.84
TCF (Time Correction Factor): 1.0226

CREW WEIGHT LIMIT: 1802 LBS.

YACHT NAME: AQUARIUS
DESIGN: J-29 MH IB
OWNER: Matthew Newberry
CERTIFICATE: STND
CLASSIFICATION: DSPL
SAIL NO: 41229
POWER: IB
CLUB: EWYC

LOA: 29.50 FT.
LWL: 25.00 FT.
BEAM: 11.00 FT.
DRAFT: 5.60 FT.
DISPLACEMENT: 6000 LBS.
BALLAST: 2100 LBS.
SAIL AREA: 450 SQ. FT.
BASE SPIN: 714 SQ. FT
EST. FORESTAY: 41.76 FT.

I: 40.00 FT.
ISP: 40.00 FT.
J: 12.00 FT.
JSP/TPS: 15.00 FT.
P: 35.00 FT.
E: 12.00 FT.
SADR: 21.87
DLR: 171.43

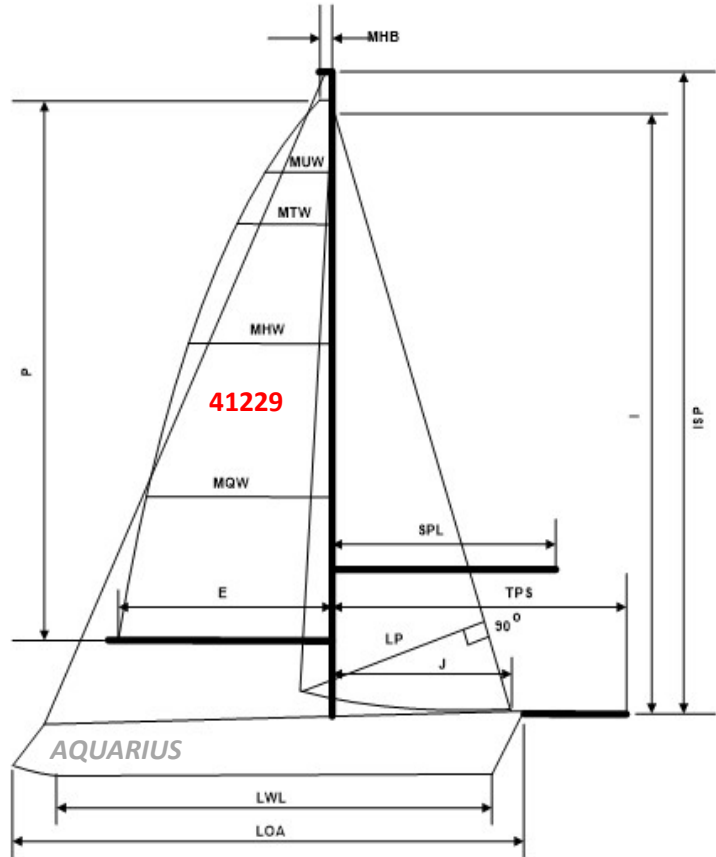

HANDICAP ADJUSTMENTS

124% Asym Declared

Adjustments must be requested by the owner and are only made based on visual inspection and/or physical measurement by an authorized PHRF-SS measurer. Fixed Prop credit is for 3-bladed or more fixed prop in aperture or on exposed strut. Asymmetric credit is for an aftermarket sprit pole per Section 20 – Asymmetric Spinnakers. If Asymmetric Credit is given, a symmetrical spinnaker may not be flown at any event designated PHRF-SS. Codes appear in Section 8 - Handicap Adjustments of the PHRF-SS Rules & Bylaws.

Owner Signature: _____

My signature attests to the fact that all the information contained on this certificate is true and correct to the best of my knowledge and that I have not made any modifications to the boat which have not been reported to PHRF-SS.

Certificate Issue: 4/14/2024

Certificate Expires: 3/31/2025



SOUTH SHORE PHRF HANDICAP CERTIFICATE

PHRF-SS, LLC., PO Box 347021, Cleveland, OH 44134

<http://phrfss.org>

HCP (Handicap): 135 sec/nm
JAM (Jib & Main): 141 sec/nm
PPF (Perf Prediction Factor): 10.54
TCF (Time Correction Factor): 0.9891

CREW WEIGHT LIMIT: 1914 LBS.

YACHT NAME: EN PASSANT
DESIGN: DEHLER 34
OWNER: Jeffrey Posner
CERTIFICATE: STND
CLASSIFICATION: DSPL
SAIL NO: 85
POWER: IB
CLUB: ELYC

LOA: 33.13 FT.
LWL: 27.23 FT.
BEAM: 11.15 FT.
DRAFT: 5.74 FT.
DISPLACEMENT: 8818 LBS.
BALLAST: 3968 LBS.
SAIL AREA: 492 SQ. FT.
BASE SPIN: 691 SQ. FT.
EST. FORESTAY: 40.52 FT.

I: 38.71 FT.
ISP: 38.71 FT.
J: 11.97 FT.
JSP/TPS: 11.97 FT.
P: 38.71 FT.
E: 13.45 FT.
SADR: 18.50
DLR: 194.98

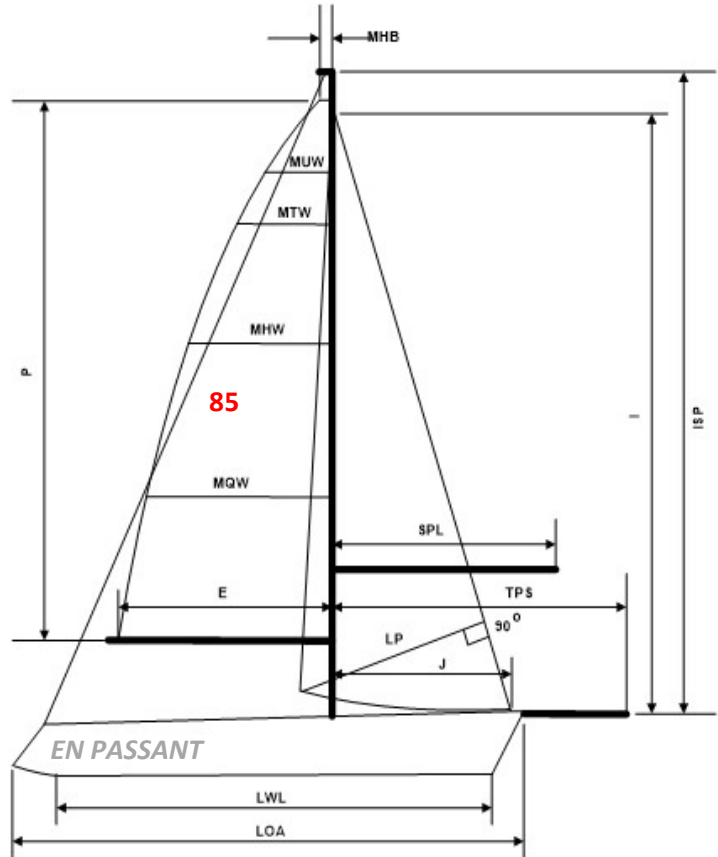

HANDICAP ADJUSTMENTS

Adjustments must be requested by the owner and are only made based on visual inspection and/or physical measurement by an authorized PHRF-SS measurer. Fixed Prop credit is for 3-bladed or more fixed prop in aperture or on exposed strut. Asymmetric credit is for an aftermarket sprit pole per Section 20 – Asymmetric Spinnakers. If Asymmetric Credit is given, a symmetrical spinnaker may not be flown at any event designated PHRF-SS. Codes appear in Section 8 - Handicap Adjustments of the PHRF-SS Rules & Bylaws.

Owner Signature: _____

My signature attests to the fact that all the information contained on this certificate is true and correct to the best of my knowledge and that I have not made any modifications to the boat which have not been reported to PHRF-SS.

Certificate Issue: 2/27/2024

Certificate Expires: 3/31/2025



SOUTH SHORE PHRF HANDICAP CERTIFICATE

PHRF-SS, LLC., PO Box 347021, Cleveland, OH 44134

<http://phrfss.org>

HCP (Handicap): 84 sec/nm
JAM (Jib & Main): 96 sec/nm
PPF (Perf Prediction Factor): 4.78
TCF (Time Correction Factor): 1.0903

CREW WEIGHT LIMIT: 1835 LBS.

YACHT NAME: SPACEMAN SPIFF
DESIGN: J-88
OWNER: Rob Ruhlman
CERTIFICATE: **STND**
CLASSIFICATION: HPRF
SAIL NO: 111
POWER: IB
CLUB: LYC

LOA: 29.19 FT.
LWL: 26.84 FT.
BEAM: 9.50 FT.
DRAFT: 6.50 FT.
DISPLACEMENT: 4990 LBS.
BALLAST: 1830 LBS.
SAIL AREA: 439 SQ. FT.
BASE SPIN: 693 SQ. FT
EST. FORESTAY: 43.10 FT.

I: 38.67 FT.
ISP: 41.60 FT.
J: 11.28 FT.
JSP/TPS: 18.77 FT.
P: 36.82 FT.
E: 12.00 FT.
SADR: 24.12
DLR: 115.21

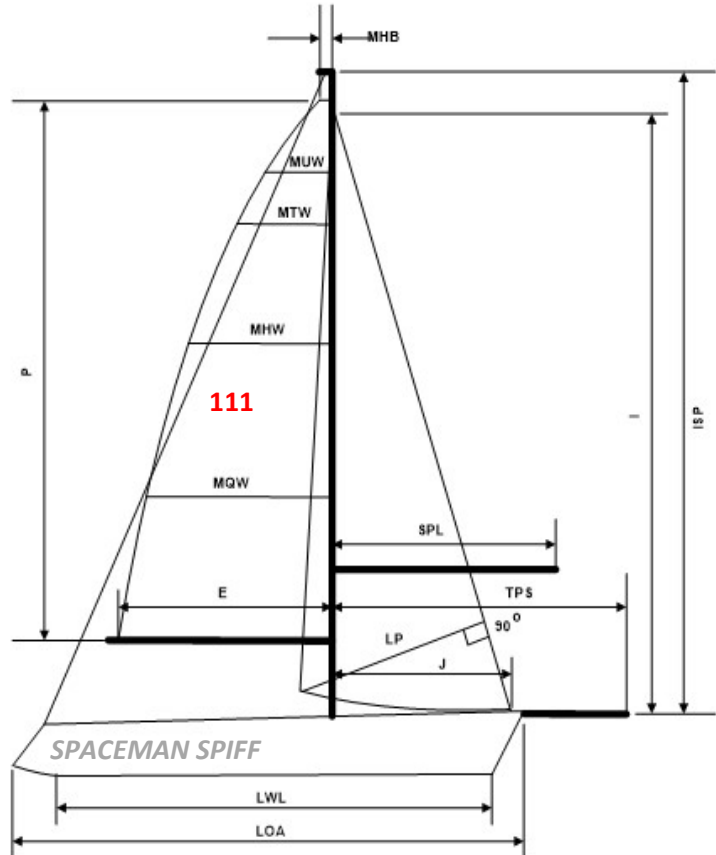

HANDICAP ADJUSTMENTS

105% JIB, 95 SQM (1023 SQ. FT)

Adjustments must be requested by the owner and are only made based on visual inspection and/or physical measurement by an authorized PHRF-SS measurer. Fixed Prop credit is for 3-bladed or more fixed prop in aperture or on exposed strut. Asymmetric credit is for an aftermarket sprit pole per Section 20 – Asymmetric Spinnakers. If Asymmetric Credit is given, a symmetrical spinnaker may not be flown at any event designated PHRF-SS. Codes appear in Section 8 - Handicap Adjustments of the PHRF-SS Rules & Bylaws.

Owner Signature: _____

My signature attests to the fact that all the information contained on this certificate is true and correct to the best of my knowledge and that I have not made any modifications to the boat which have not been reported to PHRF-SS.

Certificate Issue: 3/13/2024

Certificate Expires: 3/31/2025



SOUTH SHORE PHRF HANDICAP CERTIFICATE

PHRF-SS, LLC., PO Box 347021, Cleveland, OH 44134

<http://phrfss.org>

HCP (Handicap): 39 sec/nm
JAM (Jib & Main): 51 sec/nm
PPF (Perf Prediction Factor): 5.02
TCF (Time Correction Factor): 1.1985

CREW WEIGHT LIMIT: 2230 LBS.

YACHT NAME: SPACEMAN SPIFF
DESIGN: J-111
OWNER: Rob Ruhlman
CERTIFICATE: **ODR**
CLASSIFICATION: DSPL
SAIL NO: 134
POWER: IB
CLUB: LYC

LOA: 36.42 FT.
LWL: 32.71 FT.
BEAM: 10.80 FT.
DRAFT: 7.18 FT.
DISPLACEMENT: 9370 LBS.
BALLAST: 3516 LBS.
SAIL AREA: 659 SQ. FT.
BASE SPIN: 1047 SQ. FT
EST. FORESTAY: 53.07 FT.

I: 47.74 FT.
ISP: 51.23 FT.
J: 13.85 FT.
JSP/TPS: 21.33 FT.
P: 45.24 FT.
E: 14.50 FT.
SADR: 23.79
DLR: 119.52

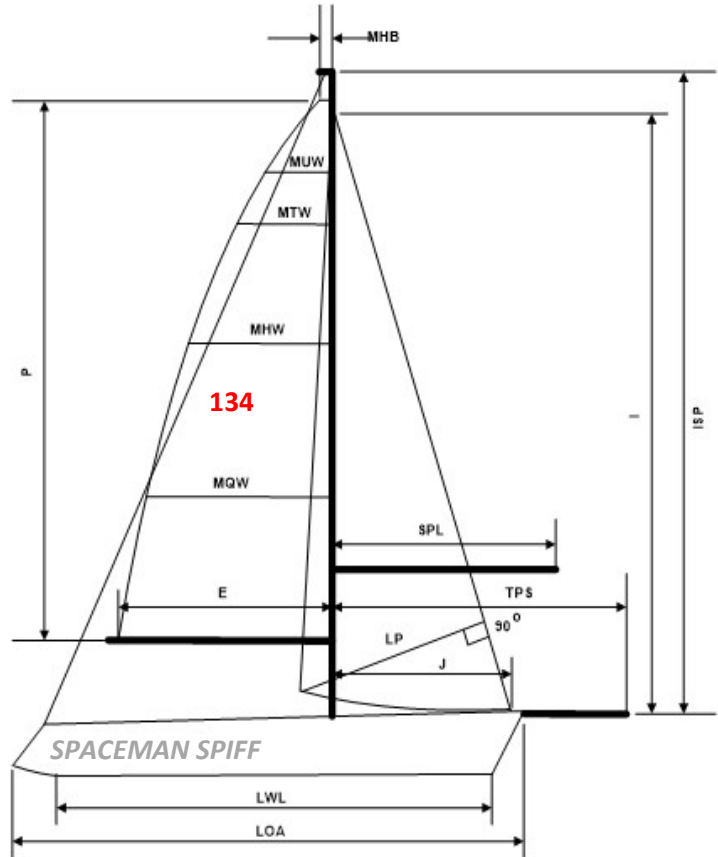

HANDICAP ADJUSTMENTS

106% JIB, 130 SQM (1399 SQ. FT)

Adjustments must be requested by the owner and are only made based on visual inspection and/or physical measurement by an authorized PHRF-SS measurer. Fixed Prop credit is for 3-bladed or more fixed prop in aperture or on exposed strut. Asymmetric credit is for an aftermarket sprit pole per Section 20 – Asymmetric Spinnakers. If Asymmetric Credit is given, a symmetrical spinnaker may not be flown at any event designated PHRF-SS. Codes appear in Section 8 - Handicap Adjustments of the PHRF-SS Rules & Bylaws.

Owner Signature: _____

My signature attests to the fact that all the information contained on this certificate is true and correct to the best of my knowledge and that I have not made any modifications to the boat which have not been reported to PHRF-SS.

Certificate Issue: 3/13/2024

Certificate Expires: 3/31/2025



SOUTH SHORE PHRF HANDICAP CERTIFICATE

PHRF-SS, LLC., PO Box 347021, Cleveland, OH 44134

<http://phrfss.org>

HCP (Handicap): 144 sec/nm
JAM (Jib & Main): 154 sec/nm
PPF (Perf Prediction Factor): 13.58
TCF (Time Correction Factor): 0.9731

CREW WEIGHT LIMIT: 1970 LBS.

YACHT NAME: WILEAWAY
DESIGN: HUNTER 34
OWNER: Philip Rush
CERTIFICATE: STND
CLASSIFICATION: DSPL
SAIL NO: 32595
POWER: IB
CLUB: FCYC

LOA: 34.42 FT.
LWL: 28.25 FT.
BEAM: 11.58 FT.
DRAFT: 5.50 FT.
DISPLACEMENT: 11820 LBS.
BALLAST: 5000 LBS.
SAIL AREA: 557 SQ. FT.
BASE SPIN: 967 SQ. FT
EST. FORESTAY: 49.37 FT.

I: 46.00 FT.
ISP: 47.42 FT.
J: 13.75 FT.
JSP/TPS: 13.75 FT.
P: 41.00 FT.
E: 11.75 FT.
SADR: 17.24
DLR: 234.05

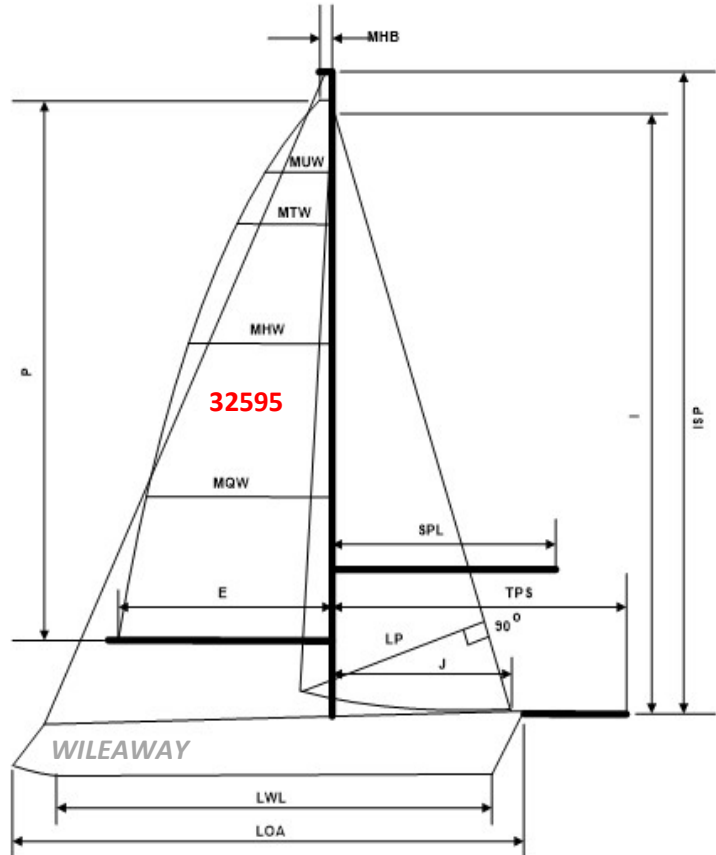

HANDICAP ADJUSTMENTS

Adjustments must be requested by the owner and are only made based on visual inspection and/or physical measurement by an authorized PHRF-SS measurer. Fixed Prop credit is for 3-bladed or more fixed prop in aperture or on exposed strut. Asymmetric credit is for an aftermarket sprit pole per Section 20 – Asymmetric Spinnakers. If Asymmetric Credit is given, a symmetrical spinnaker may not be flown at any event designated PHRF-SS. Codes appear in Section 8 - Handicap Adjustments of the PHRF-SS Rules & Bylaws.

Owner Signature: _____

My signature attests to the fact that all the information contained on this certificate is true and correct to the best of my knowledge and that I have not made any modifications to the boat which have not been reported to PHRF-SS.

Certificate Issue: 4/25/2024

Certificate Expires: 3/31/2025



SOUTH SHORE PHRF HANDICAP CERTIFICATE

PHRF-SS, LLC., PO Box 347021, Cleveland, OH 44134

<http://phrfss.org>

HCP (Handicap): 144 sec/nm
JAM (Jib & Main): 154 sec/nm
PPF (Perf Prediction Factor): 3.04
TCF (Time Correction Factor): 0.9731

CREW WEIGHT LIMIT: 1398 LBS.

YACHT NAME: ULTIMATE RUSH
DESIGN: ULTIMATE 20
OWNER: Matthew Rush
CERTIFICATE: **STND**
CLASSIFICATION: HPRF
SAIL NO: 38
POWER: OB
CLUB: LeYC

LOA: 20.83 FT.
LWL: 18.00 FT.
BEAM: 8.50 FT.
DRAFT: 5.00 FT.
DISPLACEMENT: 1260 LBS.
BALLAST: 450 LBS.
SAIL AREA: 231 SQ. FT.
BASE SPIN: 282 SQ. FT
EST. FORESTAY: 28.44 FT.

I: 26.08 FT.
ISP: 27.58 FT.
J: 6.96 FT.
JSP/TPS: 12.79 FT.
P: 27.32 FT.
E: 10.25 FT.
SADR: 31.71
DLR: 96.45

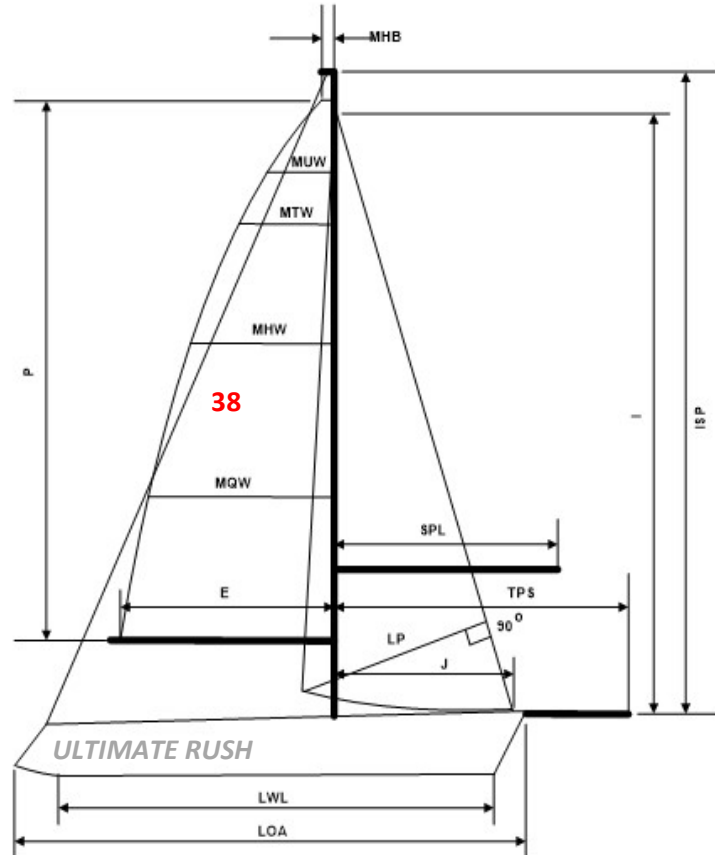

HANDICAP ADJUSTMENTS

Adjustments must be requested by the owner and are only made based on visual inspection and/or physical measurement by an authorized PHRF-SS measurer. Fixed Prop credit is for 3-bladed or more fixed prop in aperture or on exposed strut. Asymmetric credit is for an aftermarket sprit pole per Section 20 – Asymmetric Spinnakers. If Asymmetric Credit is given, a symmetrical spinnaker may not be flown at any event designated PHRF-SS. Codes appear in Section 8 - Handicap Adjustments of the PHRF-SS Rules & Bylaws.

Owner Signature: _____

My signature attests to the fact that all the information contained on this certificate is true and correct to the best of my knowledge and that I have not made any modifications to the boat which have not been reported to PHRF-SS.

Certificate Issue: 3/1/2024

Certificate Expires: 3/31/2025



SOUTH SHORE PHRF HANDICAP CERTIFICATE

PHRF-SS, LLC., PO Box 347021, Cleveland, OH 44134

<http://phrfss.org>

HCP (Handicap): 51 sec/nm
JAM (Jib & Main): 62 sec/nm
PPF (Perf Prediction Factor): 2.63
TCF (Time Correction Factor): 1.1676

CREW WEIGHT LIMIT: 2036 LBS.

YACHT NAME: RUSH
DESIGN: FT 10M
OWNER: Laurence Rush
CERTIFICATE: STND
CLASSIFICATION: HPRF
SAIL NO: 789
POWER: IB
CLUB: FCYC

LOA: 32.65 FT.
LWL: 30.31 FT.
BEAM: 9.15 FT.
DRAFT: 7.62 FT.
DISPLACEMENT: 4900 LBS.
BALLAST: 1918 LBS.
SAIL AREA: 537 SQ. FT.
BASE SPIN: 810 SQ. FT
EST. FORESTAY: 46.87 FT.

I: 39.28 FT.
ISP: 45.28 FT.
J: 12.12 FT.
JSP/TPS: 19.13 FT.
P: 40.16 FT.
E: 14.89 FT.
SADR: 29.87
DLR: 78.56

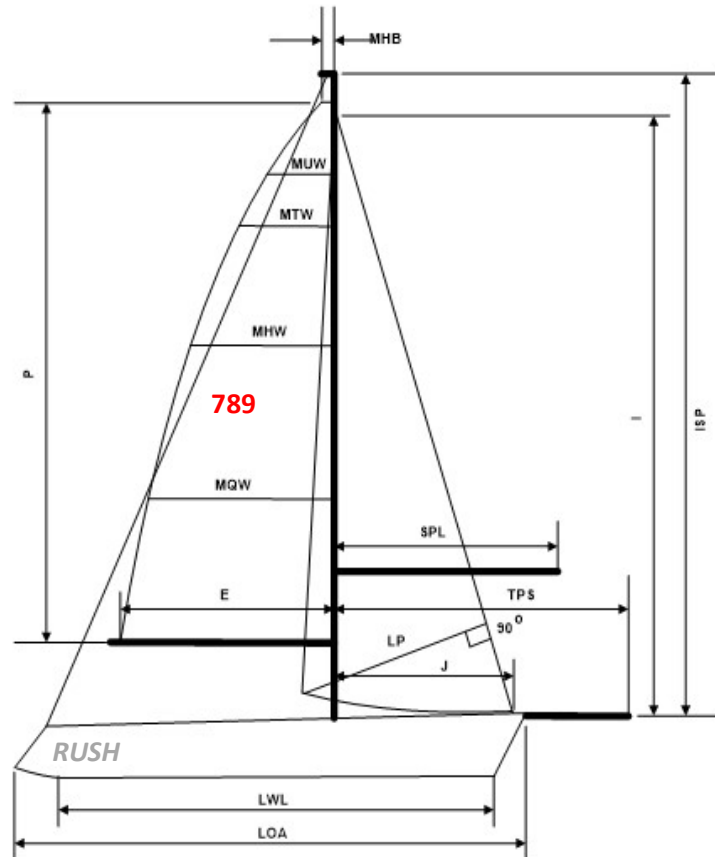

HANDICAP ADJUSTMENTS

105% JIB, 107 SQM (1150 SQ. FT.)

Adjustments must be requested by the owner and are only made based on visual inspection and/or physical measurement by an authorized PHRF-SS measurer. Fixed Prop credit is for 3-bladed or more fixed prop in aperture or on exposed strut. Asymmetric credit is for an aftermarket sprit pole per Section 20 – Asymmetric Spinnakers. If Asymmetric Credit is given, a symmetrical spinnaker may not be flown at any event designated PHRF-SS. Codes appear in Section 8 - Handicap Adjustments of the PHRF-SS Rules & Bylaws.

Owner Signature: _____

My signature attests to the fact that all the information contained on this certificate is true and correct to the best of my knowledge and that I have not made any modifications to the boat which have not been reported to PHRF-SS.

Certificate Issue: 2/27/2024

Certificate Expires: 3/31/2025



SOUTH SHORE PHRF HANDICAP CERTIFICATE

PHRF-SS, LLC., PO Box 347021, Cleveland, OH 44134

<http://phrfss.org>

HCP (Handicap): 126 sec/nm
JAM (Jib & Main): 130 sec/nm
PPF (Perf Prediction Factor): 7.59
TCF (Time Correction Factor): 1.0056

CREW WEIGHT LIMIT: 1927 LBS.

YACHT NAME: CRACKER
DESIGN: TARTAN 10 ODR
OWNER: Karen Sackett-Rampe
CERTIFICATE: STND
CLASSIFICATION: DSPL
SAIL NO: 33
POWER: IB
CLUB: MHYC

LOA: 33.15 FT.
LWL: 27.00 FT.
BEAM: 9.25 FT.
DRAFT: 5.83 FT.
DISPLACEMENT: 7100 LBS.
BALLAST: 3340 LBS.
SAIL AREA: 488 SQ. FT.
BASE SPIN: 633 SQ. FT
EST. FORESTAY: 37.00 FT.

I: 35.00 FT.
ISP: 35.00 FT.
J: 12.00 FT.
JSP/TPS: 12.00 FT.
P: 40.30 FT.
E: 13.80 FT.
SADR: 21.21
DLR: 161.03

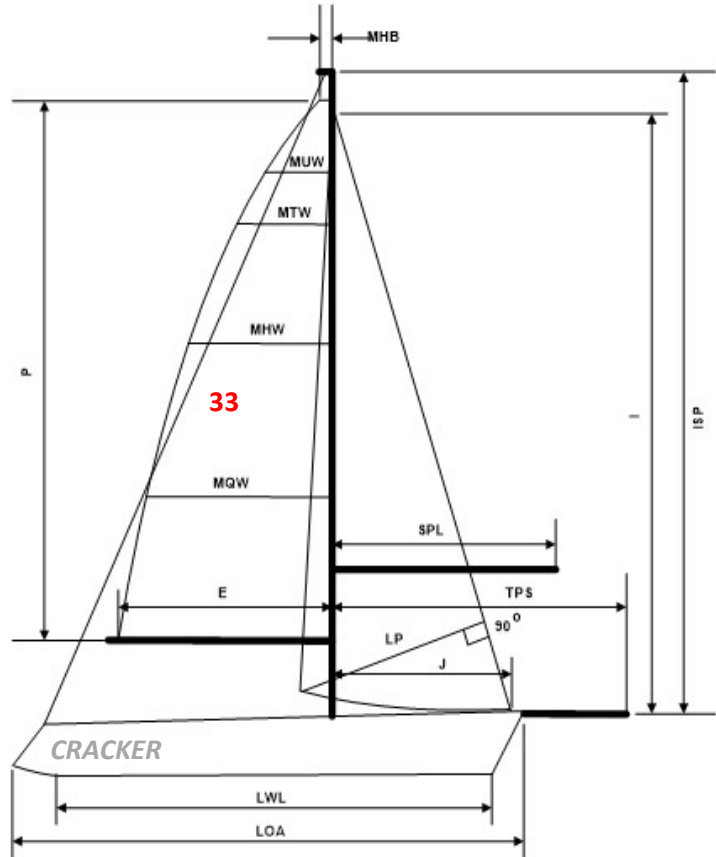

HANDICAP ADJUSTMENTS

Adjustments must be requested by the owner and are only made based on visual inspection and/or physical measurement by an authorized PHRF-SS measurer. Fixed Prop credit is for 3-bladed or more fixed prop in aperture or on exposed strut. Asymmetric credit is for an aftermarket sprit pole per Section 20 – Asymmetric Spinnakers. If Asymmetric Credit is given, a symmetrical spinnaker may not be flown at any event designated PHRF-SS. Codes appear in Section 8 - Handicap Adjustments of the PHRF-SS Rules & Bylaws.

Owner Signature: _____

My signature attests to the fact that all the information contained on this certificate is true and correct to the best of my knowledge and that I have not made any modifications to the boat which have not been reported to PHRF-SS.

Certificate Issue: 3/9/2024

Certificate Expires: 3/31/2025



SOUTH SHORE PHRF HANDICAP CERTIFICATE

PHRF-SS, LLC., PO Box 347021, Cleveland, OH 44134

<http://phrfss.org>

HCP (Handicap): 84 sec/nm
JAM (Jib & Main): 93 sec/nm
PPF (Perf Prediction Factor): 7.54
TCF (Time Correction Factor): 1.0903

CREW WEIGHT LIMIT: 2154 LBS.

YACHT NAME: PAINKILLER
DESIGN: J-36
OWNER: Mark Saffell
CERTIFICATE: **STND**
CLASSIFICATION: DSPL
SAIL NO: 36546
POWER: IB
CLUB: EWYC

LOA: 35.95 FT.
LWL: 30.50 FT.
BEAM: 11.76 FT.
DRAFT: 6.60 FT.
DISPLACEMENT: 10570 LBS.
BALLAST: 4600 LBS.
SAIL AREA: 662 SQ. FT.
BASE SPIN: 925 SQ. FT
EST. FORESTAY: 46.37 FT.

I: 44.21 FT.
ISP: 44.21 FT.
J: 14.00 FT.
JSP/TPS: 18.20 FT.
P: 47.00 FT.
E: 15.00 FT.
SADR: 22.07
DLR: 166.31

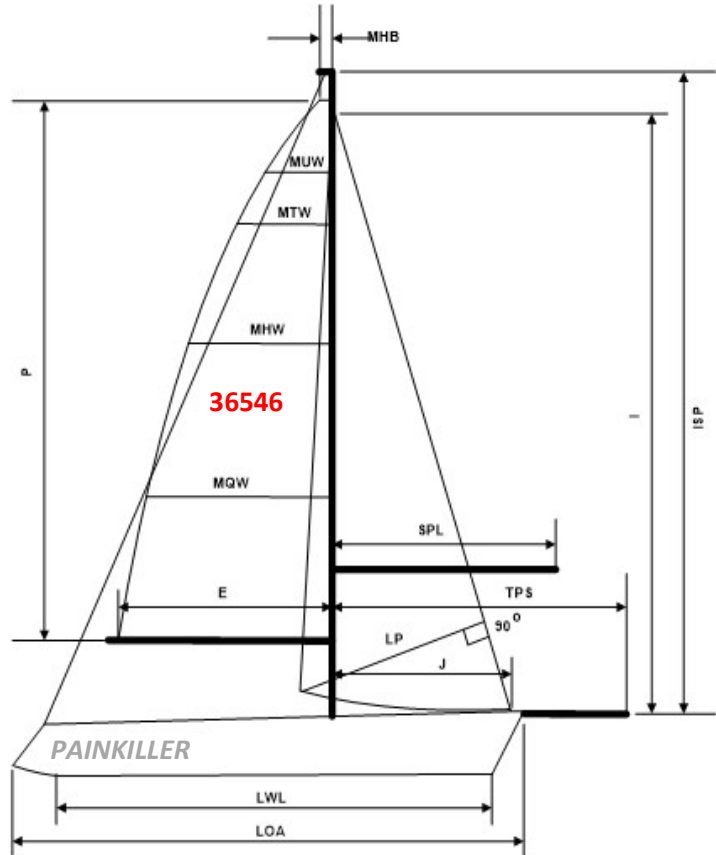

HANDICAP ADJUSTMENTS

135% Asym Credit. Limited to Asym ONLY. No Penalty.

Adjustments must be requested by the owner and are only made based on visual inspection and/or physical measurement by an authorized PHRF-SS measurer. Fixed Prop credit is for 3-bladed or more fixed prop in aperture or on exposed strut. Asymmetric credit is for an aftermarket sprit pole per Section 20 – Asymmetric Spinnakers. If Asymmetric Credit is given, a symmetrical spinnaker may not be flown at any event designated PHRF-SS. Codes appear in Section 8 - Handicap Adjustments of the PHRF-SS Rules & Bylaws.

Owner Signature: _____

My signature attests to the fact that all the information contained on this certificate is true and correct to the best of my knowledge and that I have not made any modifications to the boat which have not been reported to PHRF-SS.

Certificate Issue: 6/23/2024

Certificate Expires: 3/31/2025



SOUTH SHORE PHRF HANDICAP CERTIFICATE

PHRF-SS, LLC., PO Box 347021, Cleveland, OH 44134

<http://phrfss.org>

HCP (Handicap): 72 sec/nm
JAM (Jib & Main): 81 sec/nm
PPF (Perf Prediction Factor): 8.15
TCF (Time Correction Factor): 1.1172

CREW WEIGHT LIMIT: 2145 LBS.

YACHT NAME: COLTRANE
DESIGN: J-35
OWNER: Michael Savage
CERTIFICATE: STND
CLASSIFICATION: DSPL
SAIL NO: 42207
POWER: IB
CLUB: EWM

LOA: 35.50 FT.
LWL: 30.00 FT.
BEAM: 11.80 FT.
DRAFT: 6.90 FT.
DISPLACEMENT: 10500 LBS.
BALLAST: 4400 LBS.
SAIL AREA: 636 SQ. FT.
BASE SPIN: 1031 SQ. FT.
EST. FORESTAY: 48.89 FT.

I: 46.60 FT.
ISP: 46.60 FT.
J: 14.80 FT.
JSP/TPS: 14.80 FT.
P: 41.60 FT.
E: 14.00 FT.
SADR: 21.30
DLR: 173.61

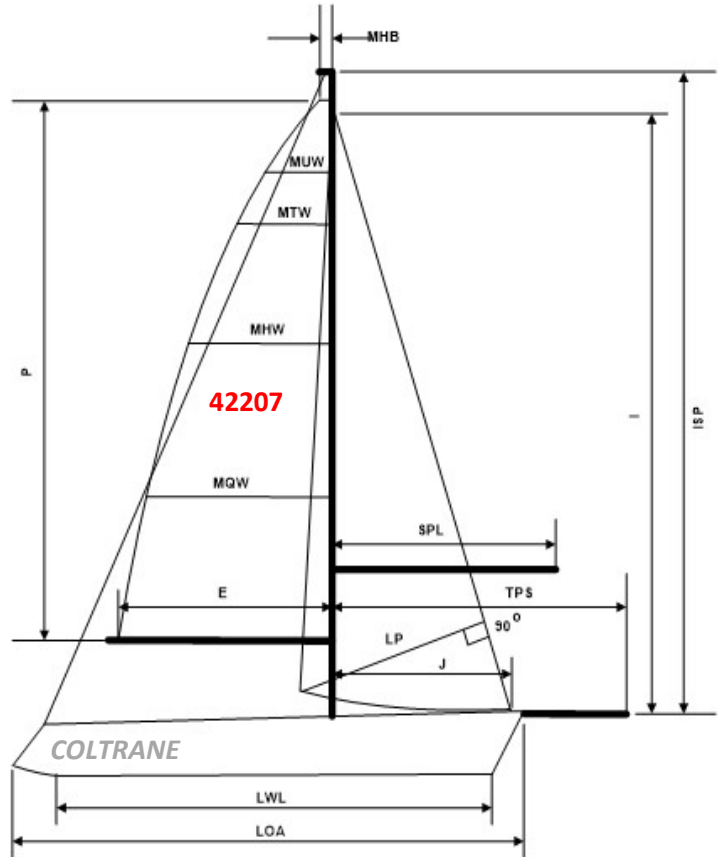

HANDICAP ADJUSTMENTS

Adjustments must be requested by the owner and are only made based on visual inspection and/or physical measurement by an authorized PHRF-SS measurer. Fixed Prop credit is for 3-bladed or more fixed prop in aperture or on exposed strut. Asymmetric credit is for an aftermarket sprit pole per Section 20 – Asymmetric Spinnakers. If Asymmetric Credit is given, a symmetrical spinnaker may not be flown at any event designated PHRF-SS. Codes appear in Section 8 - Handicap Adjustments of the PHRF-SS Rules & Bylaws.

Owner Signature: _____

My signature attests to the fact that all the information contained on this certificate is true and correct to the best of my knowledge and that I have not made any modifications to the boat which have not been reported to PHRF-SS.

Certificate Issue: 2/28/2024

Certificate Expires: 3/31/2025



SOUTH SHORE PHRF HANDICAP CERTIFICATE

PHRF-SS, LLC., PO Box 347021, Cleveland, OH 44134

<http://phrfss.org>

HCP (Handicap): 147 sec/nm
JAM (Jib & Main): 157 sec/nm
PPF (Perf Prediction Factor): 12.39
TCF (Time Correction Factor): 0.9679

CREW WEIGHT LIMIT: 1957 LBS.

YACHT NAME: LOTTE ROSE
DESIGN: CAT 34 MK II
OWNER: Bob Savinell
CERTIFICATE: STND
CLASSIFICATION: DSPL
SAIL NO: 1312
POWER: IB
CLUB: EWYC

LOA: 34.50 FT.
LWL: 29.83 FT.
BEAM: 11.75 FT.
DRAFT: 5.58 FT.
DISPLACEMENT: 11950 LBS.
BALLAST: 5000 LBS.
SAIL AREA: 528 SQ. FT.
BASE SPIN: 885 SQ. FT
EST. FORESTAY: 46.02 FT.

I: 44.00 FT.
ISP: 44.00 FT.
J: 13.50 FT.
JSP/TPS: 13.50 FT.
P: 38.50 FT.
E: 12.00 FT.
SADR: 16.22
DLR: 200.98

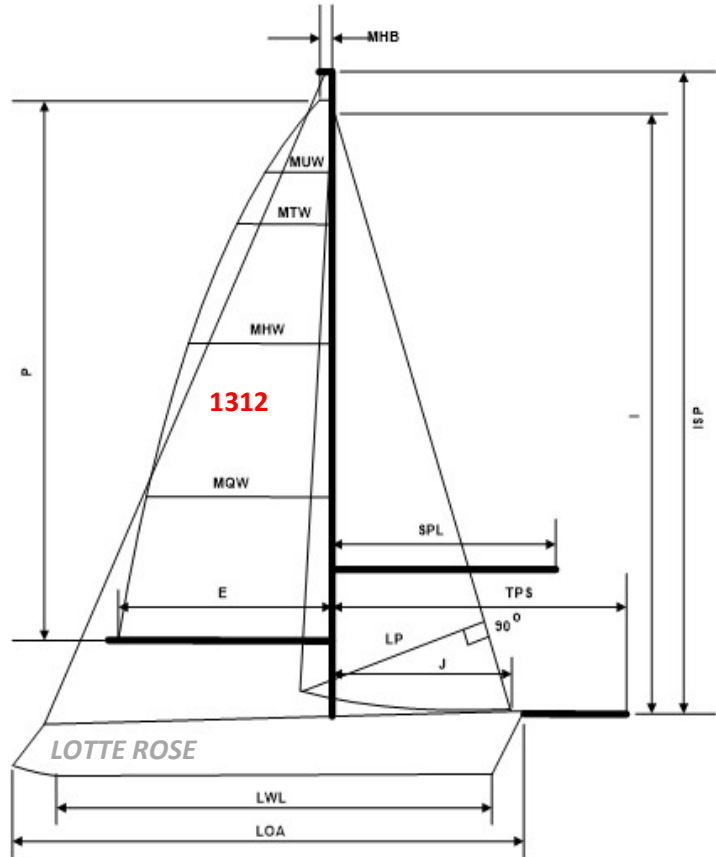

HANDICAP ADJUSTMENTS

Adjustments must be requested by the owner and are only made based on visual inspection and/or physical measurement by an authorized PHRF-SS measurer. Fixed Prop credit is for 3-bladed or more fixed prop in aperture or on exposed strut. Asymmetric credit is for an aftermarket sprit pole per Section 20 – Asymmetric Spinnakers. If Asymmetric Credit is given, a symmetrical spinnaker may not be flown at any event designated PHRF-SS. Codes appear in Section 8 - Handicap Adjustments of the PHRF-SS Rules & Bylaws.

Owner Signature: _____

My signature attests to the fact that all the information contained on this certificate is true and correct to the best of my knowledge and that I have not made any modifications to the boat which have not been reported to PHRF-SS.

Certificate Issue: 5/19/2024

Certificate Expires: 3/31/2025



SOUTH SHORE PHRF HANDICAP CERTIFICATE

PHRF-SS, LLC., PO Box 347021, Cleveland, OH 44134

<http://phrfss.org>

HCP (Handicap): 90 sec/nm
JAM (Jib & Main): 100 sec/nm
PPF (Perf Prediction Factor): 6.74
TCF (Time Correction Factor): 1.0773

CREW WEIGHT LIMIT: 2061 LBS.

YACHT NAME: FALL LINE
DESIGN: J-105 ODR
OWNER: Chip Schaffner
CERTIFICATE: ODR
CLASSIFICATION: DSPL
SAIL NO: 144
POWER: IB
CLUB: EWYC

LOA: 34.50 FT.
LWL: 29.50 FT.
BEAM: 11.00 FT.
DRAFT: 6.50 FT.
DISPLACEMENT: 8575 LBS.
BALLAST: 3400 LBS.
SAIL AREA: 577 SQ. FT.
BASE SPIN: 851 SQ. FT
EST. FORESTAY: 44.21 FT.

I: 40.60 FT.
ISP: 42.10 FT.
J: 13.50 FT.
JSP/TPS: 19.00 FT.
P: 41.50 FT.
E: 14.60 FT.
SADR: 22.11
DLR: 149.11

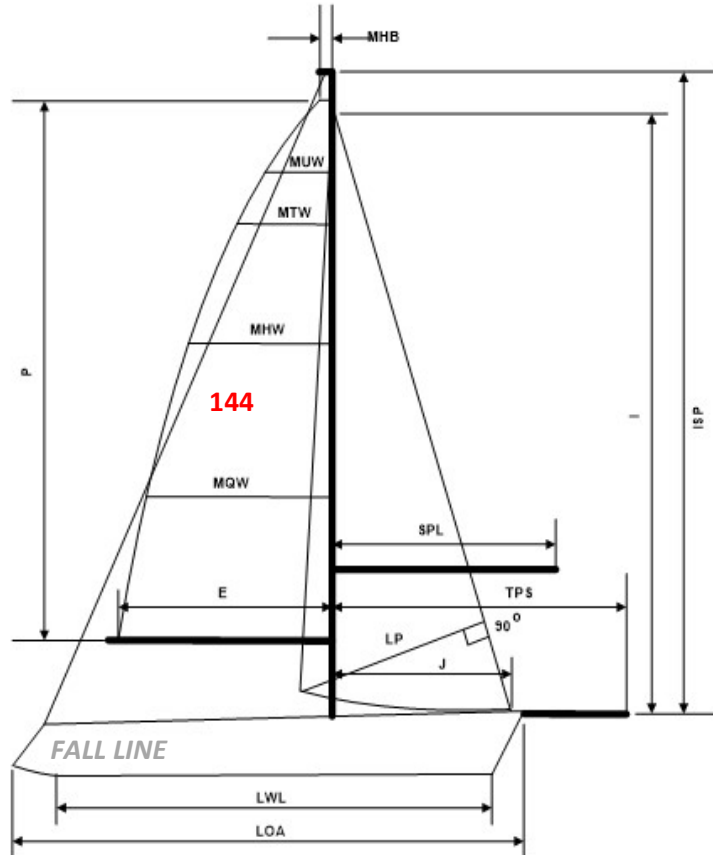

HANDICAP ADJUSTMENTS

ODR 102% JIB/89 SQM ASYM

Adjustments must be requested by the owner and are only made based on visual inspection and/or physical measurement by an authorized PHRF-SS measurer. Fixed Prop credit is for 3-bladed or more fixed prop in aperture or on exposed strut. Asymmetric credit is for an aftermarket sprit pole per Section 20 – Asymmetric Spinnakers. If Asymmetric Credit is given, a symmetrical spinnaker may not be flown at any event designated PHRF-SS. Codes appear in Section 8 - Handicap Adjustments of the PHRF-SS Rules & Bylaws.

Owner Signature: _____

My signature attests to the fact that all the information contained on this certificate is true and correct to the best of my knowledge and that I have not made any modifications to the boat which have not been reported to PHRF-SS.

Certificate Issue: 3/1/2024

Certificate Expires: 3/31/2025



SOUTH SHORE PHRF HANDICAP CERTIFICATE

PHRF-SS, LLC., PO Box 347021, Cleveland, OH 44134

<http://phrfss.org>

HCP (Handicap): 39 sec/nm
JAM (Jib & Main): 51 sec/nm
PPF (Perf Prediction Factor): 5.02
TCF (Time Correction Factor): 1.1985

CREW WEIGHT LIMIT: 2230 LBS.

YACHT NAME: PAPA'S TOY
DESIGN: J-111
OWNER: Hugh Scott Seaholm
CERTIFICATE: ODR
CLASSIFICATION: DSPL
SAIL NO: 93
POWER: IB
CLUB: MHYC

LOA: 36.42 FT.
LWL: 32.71 FT.
BEAM: 10.80 FT.
DRAFT: 7.18 FT.
DISPLACEMENT: 9370 LBS.
BALLAST: 3516 LBS.
SAIL AREA: 659 SQ. FT.
BASE SPIN: 1047 SQ. FT
EST. FORESTAY: 53.07 FT.

I: 47.74 FT.
ISP: 51.23 FT.
J: 13.85 FT.
JSP/TPS: 21.33 FT.
P: 45.24 FT.
E: 14.50 FT.
SADR: 23.79
DLR: 119.52

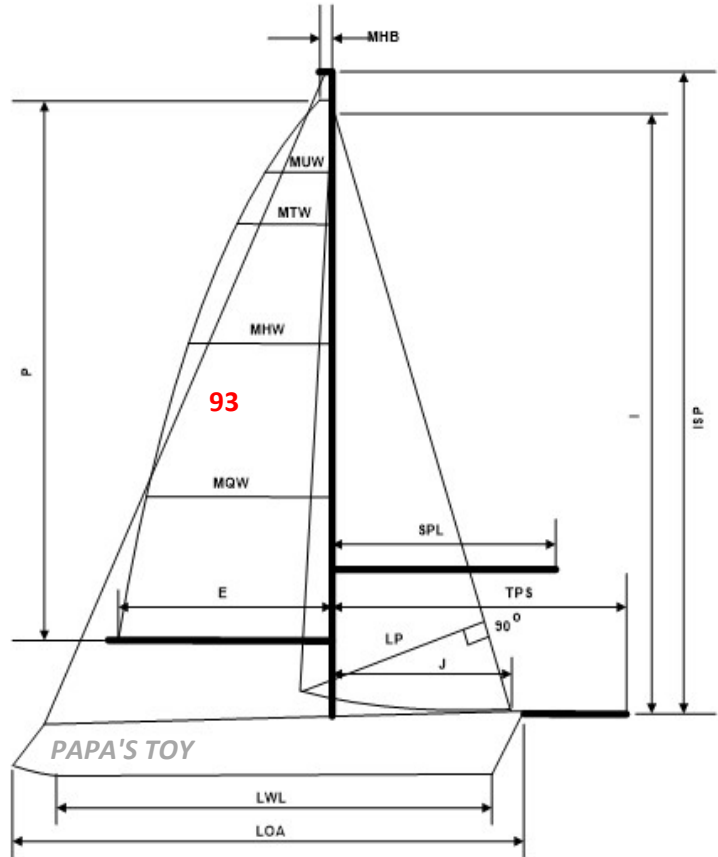

HANDICAP ADJUSTMENTS

106% JIB, 130 SQM (1399 SQ. FT)

Adjustments must be requested by the owner and are only made based on visual inspection and/or physical measurement by an authorized PHRF-SS measurer. Fixed Prop credit is for 3-bladed or more fixed prop in aperture or on exposed strut. Asymmetric credit is for an aftermarket sprit pole per Section 20 – Asymmetric Spinnakers. If Asymmetric Credit is given, a symmetrical spinnaker may not be flown at any event designated PHRF-SS. Codes appear in Section 8 - Handicap Adjustments of the PHRF-SS Rules & Bylaws.

Owner Signature: _____

My signature attests to the fact that all the information contained on this certificate is true and correct to the best of my knowledge and that I have not made any modifications to the boat which have not been reported to PHRF-SS.

Certificate Issue: 4/25/2024

Certificate Expires: 3/31/2025



SOUTH SHORE PHRF HANDICAP CERTIFICATE

PHRF-SS, LLC., PO Box 347021, Cleveland, OH 44134

<http://phrfss.org>

HCP (Handicap): 81 sec/nm
JAM (Jib & Main): 91 sec/nm
PPF (Perf Prediction Factor): 3.44
TCF (Time Correction Factor): 1.0969

CREW WEIGHT LIMIT: 2007 LBS.

YACHT NAME: LIONHEART
DESIGN: SOVEREL 33-2 (Keel)
OWNER: Steven Sears
CERTIFICATE: PRLM
CLASSIFICATION: DSPL
SAIL NO: 40451
POWER: IB
CLUB: GRSC

LOA: 33.00 FT.
LWL: 30.42 FT.
BEAM: 11.00 FT.
DRAFT: 5.83 FT.
DISPLACEMENT: 5800 LBS.
BALLAST: 3200 LBS.
SAIL AREA: 539 SQ. FT.
BASE SPIN: 839 SQ. FT.
EST. FORESTAY: 46.02 FT.

I: 42.50 FT.
ISP: 44.20 FT.
J: 12.80 FT.
JSP/TPS: 16.80 FT.
P: 41.00 FT.
E: 13.00 FT.
SADR: 26.77
DLR: 91.98

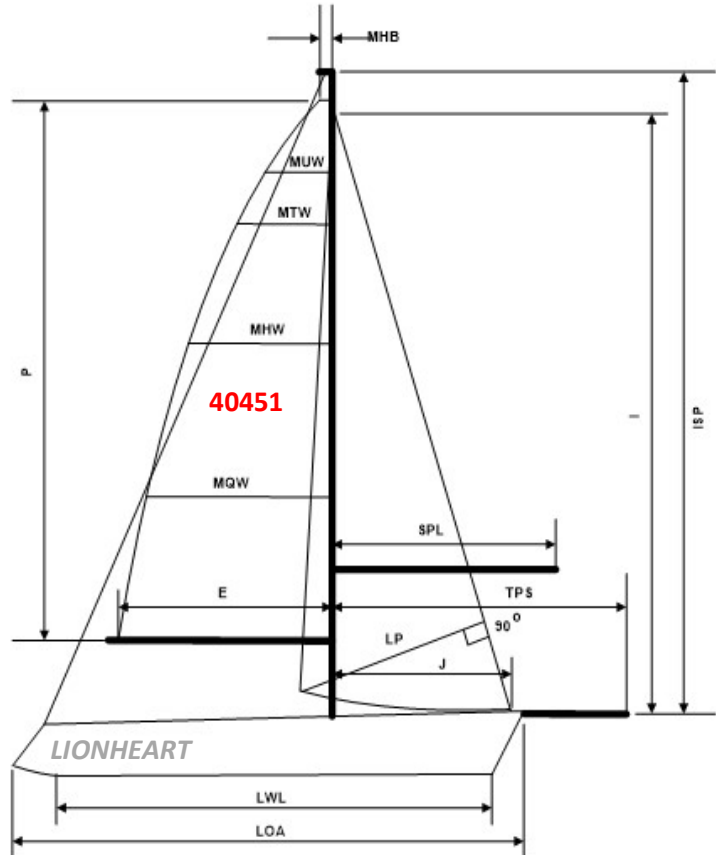

HANDICAP ADJUSTMENTS

+3 RFG / -3 ISP / -6 BLST / -3 ASYM

Adjustments must be requested by the owner and are only made based on visual inspection and/or physical measurement by an authorized PHRF-SS measurer. Fixed Prop credit is for 3-bladed 33-2 (Keel) or more fixed prop in aperture or on exposed strut. Asymmetric credit is for an aftermarket sprit pole per Section 20 – Asymmetric Spinnakers. If Asymmetric Credit is given, a symmetrical spinnaker may not be flown at any event designated PHRF-SS. Codes appear in Section 8 - Handicap Adjustments of the PHRF-SS Rules & Bylaws.

Owner Signature: _____

My signature attests to the fact that all the information contained on this certificate is true and correct to the best of my knowledge and that I have not made any modifications to the boat which have not been reported to PHRF-SS.

Certificate Issue: 6/13/2024

Certificate Expires: 3/31/2025



SOUTH SHORE PHRF HANDICAP CERTIFICATE

PHRF-SS, LLC., PO Box 347021, Cleveland, OH 44134

<http://phrfss.org>

HCP (Handicap): -84 sec/nm
JAM (Jib & Main): -74 sec/nm
PPF (Perf Prediction Factor): 1.86
TCF (Time Correction Factor): 1.6448

CREW WEIGHT LIMIT: 3271 LBS.

YACHT NAME: HOOLIGAN
DESIGN: TRANSPAC 52 JV
OWNER: Trey Sheehan
CERTIFICATE: STND
CLASSIFICATION: HPRF
SAIL NO: 52521
POWER: IB
CLUB: EWYC

LOA: 52.00 FT.
LWL: 48.80 FT.
BEAM: 14.53 FT.
DRAFT: 10.58 FT.
DISPLACEMENT: 17130 LBS.
BALLAST: 7393 LBS.
SAIL AREA: 1461 SQ. FT.
BASE SPIN: 2229 SQ. FT.
EST. FORESTAY: 76.82 FT.

I: 64.38 FT.
ISP: 74.07 FT.
J: 20.36 FT.
JSP/TPS: 28.95 FT.
P: 67.03 FT.
E: 24.05 FT.
SADR: 35.32
DLR: 65.80

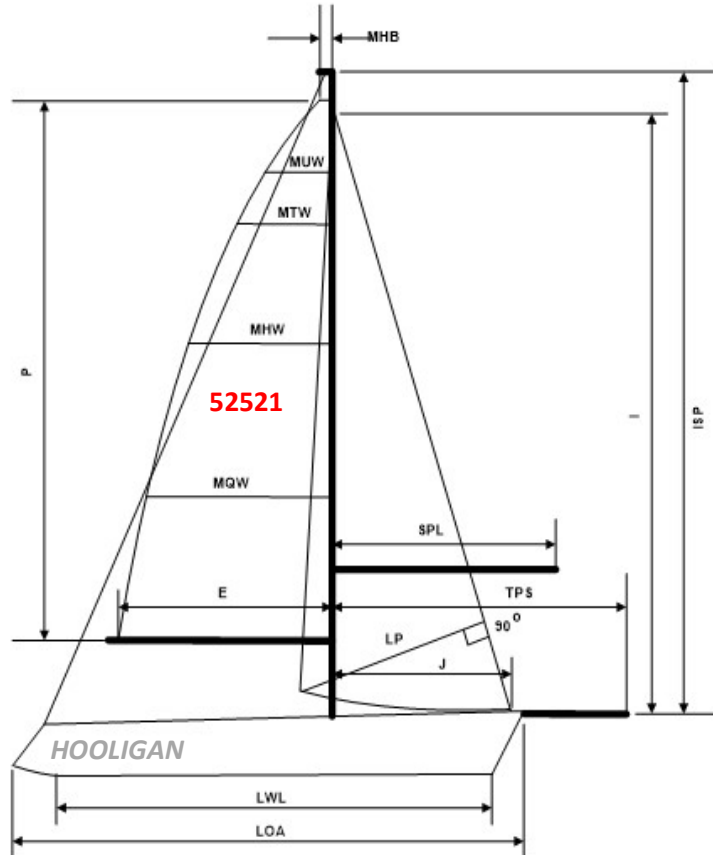

HANDICAP ADJUSTMENTS

Judel Vrolijk Design

Adjustments must be requested by the owner and are only made based on visual inspection and/or physical measurement by an authorized PHRF-SS measurer. Fixed Prop credit is for 3-bladed or more fixed prop in aperture or on exposed strut. Asymmetric credit is for an aftermarket sprit pole per Section 20 – Asymmetric Spinnakers. If Asymmetric Credit is given, a symmetrical spinnaker may not be flown at any event designated PHRF-SS. Codes appear in Section 8 - Handicap Adjustments of the PHRF-SS Rules & Bylaws.

Owner Signature: _____

My signature attests to the fact that all the information contained on this certificate is true and correct to the best of my knowledge and that I have not made any modifications to the boat which have not been reported to PHRF-SS.

Certificate Issue: 5/30/2024

Certificate Expires: 3/31/2025



SOUTH SHORE PHRF HANDICAP CERTIFICATE

PHRF-SS, LLC., PO Box 347021, Cleveland, OH 44134

<http://phrfss.org>

HCP (Handicap): 156 sec/nm
JAM (Jib & Main): 166 sec/nm
PPF (Perf Prediction Factor): 14.14
TCF (Time Correction Factor): 0.9527

CREW WEIGHT LIMIT: 1870 LBS.

YACHT NAME: APONIVI
DESIGN: CS 33 SD
OWNER: Bron Taoras
CERTIFICATE: TEMP
CLASSIFICATION: DSPL
SAIL NO: 3312
POWER: IB
CLUB: EWYC

LOA: 32.67 FT.
LWL: 26.42 FT.
BEAM: 10.67 FT.
DRAFT: 4.58 FT.
DISPLACEMENT: 10100 LBS.
BALLAST: 4400 LBS.
SAIL AREA: 503 SQ. FT.
BASE SPIN: 864 SQ. FT
EST. FORESTAY: 45.94 FT.

I: 44.00 FT.
ISP: 44.00 FT.
J: 13.20 FT.
JSP/TPS: 13.20 FT.
P: 38.00 FT.
E: 11.20 FT.
SADR: 17.29
DLR: 244.50

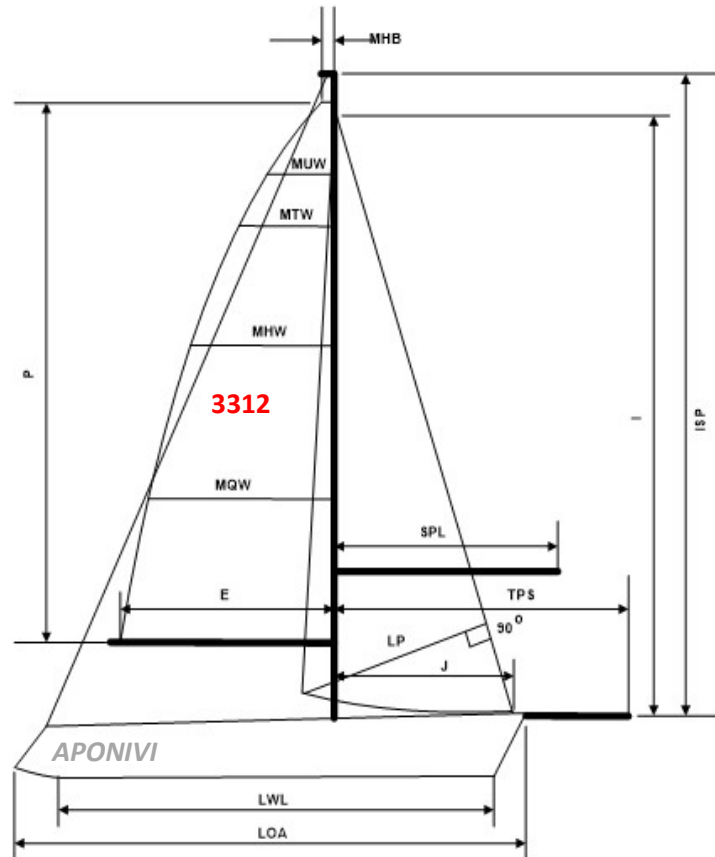

HANDICAP ADJUSTMENTS

+3RFG

Adjustments must be requested by the owner and are only made based on visual inspection and/or physical measurement by an authorized PHRF-SS measurer. Fixed Prop credit is for 3-bladed or more fixed prop in aperture or on exposed strut. Asymmetric credit is for an aftermarket sprit pole per Section 20 – Asymmetric Spinnakers. If Asymmetric Credit is given, a symmetrical spinnaker may not be flown at any event designated PHRF-SS. Codes appear in Section 8 - Handicap Adjustments of the PHRF-SS Rules & Bylaws.

Owner Signature: _____

My signature attests to the fact that all the information contained on this certificate is true and correct to the best of my knowledge and that I have not made any modifications to the boat which have not been reported to PHRF-SS.

Certificate Issue: 3/21/2024

Certificate Expires: 3/31/2025



SOUTH SHORE PHRF HANDICAP CERTIFICATE

PHRF-SS, LLC., PO Box 347021, Cleveland, OH 44134

<http://phrfss.org>

HCP (Handicap): 90 sec/nm
JAM (Jib & Main): 100 sec/nm
PPF (Perf Prediction Factor): 6.74
TCF (Time Correction Factor): 1.0773

CREW WEIGHT LIMIT: 2061 LBS.

YACHT NAME: TRIO
DESIGN: J-105 ODR
OWNER: Paul Uhler
CERTIFICATE: STND
CLASSIFICATION: DSPL
SAIL NO: 50259
POWER: IB
CLUB: EWYC

LOA: 34.50 FT.
LWL: 29.50 FT.
BEAM: 11.00 FT.
DRAFT: 6.50 FT.
DISPLACEMENT: 8575 LBS.
BALLAST: 3400 LBS.
SAIL AREA: 577 SQ. FT.
BASE SPIN: 851 SQ. FT
EST. FORESTAY: 44.21 FT.

I: 40.60 FT.
ISP: 42.10 FT.
J: 13.50 FT.
JSP/TPS: 19.00 FT.
P: 41.50 FT.
E: 14.60 FT.
SADR: 22.11
DLR: 149.11

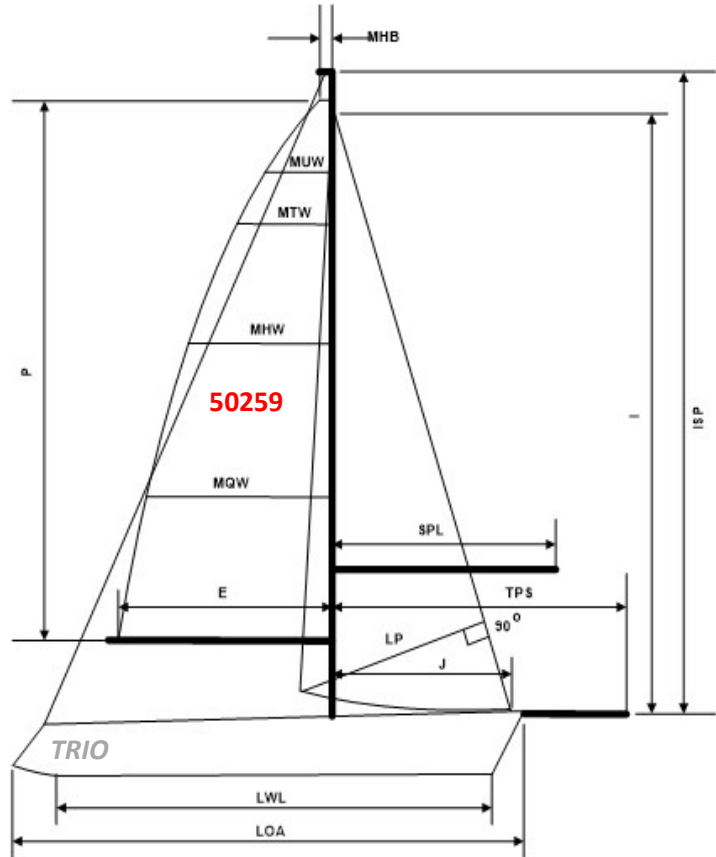

HANDICAP ADJUSTMENTS

ODR 102% JIB/89 SQM ASYM

Adjustments must be requested by the owner and are only made based on visual inspection and/or physical measurement by an authorized PHRF-SS measurer. Fixed Prop credit is for 3-bladed or more fixed prop in aperture or on exposed strut. Asymmetric credit is for an aftermarket sprit pole per Section 20 – Asymmetric Spinnakers. If Asymmetric Credit is given, a symmetrical spinnaker may not be flown at any event designated PHRF-SS. Codes appear in Section 8 - Handicap Adjustments of the PHRF-SS Rules & Bylaws.

Owner Signature: _____

My signature attests to the fact that all the information contained on this certificate is true and correct to the best of my knowledge and that I have not made any modifications to the boat which have not been reported to PHRF-SS.

Certificate Issue: 2/27/2024

Certificate Expires: 3/31/2025



SOUTH SHORE PHRF HANDICAP CERTIFICATE

PHRF-SS, LLC., PO Box 347021, Cleveland, OH 44134

<http://phrfss.org>

HCP (Handicap): 105 sec/nm
JAM (Jib & Main): 114 sec/nm
PPF (Perf Prediction Factor): 9.99
TCF (Time Correction Factor): 1.0462

CREW WEIGHT LIMIT: 2742 LBS.

YACHT NAME: HUMA
DESIGN: JEANNEAU 50 DS SD
OWNER: Marc & Jen Uhrich
CERTIFICATE: **STND**
CLASSIFICATION: DSPL
SAIL NO: 50
POWER: IB
CLUB: EWYC

LOA: 49.44 FT.
LWL: 43.04 FT.
BEAM: 14.73 FT.
DRAFT: 5.54 FT.
DISPLACEMENT: 29542 LBS.
BALLAST: 9038 LBS.
SAIL AREA: 985 SQ. FT.
BASE SPIN: 1548 SQ. FT
EST. FORESTAY: 58.33 FT.

I: 54.77 FT.
ISP: 55.27 FT.
J: 18.63 FT.
JSP/TPS: 20.74 FT.
P: 51.67 FT.
E: 18.37 FT.
SADR: 16.56
DLR: 165.42

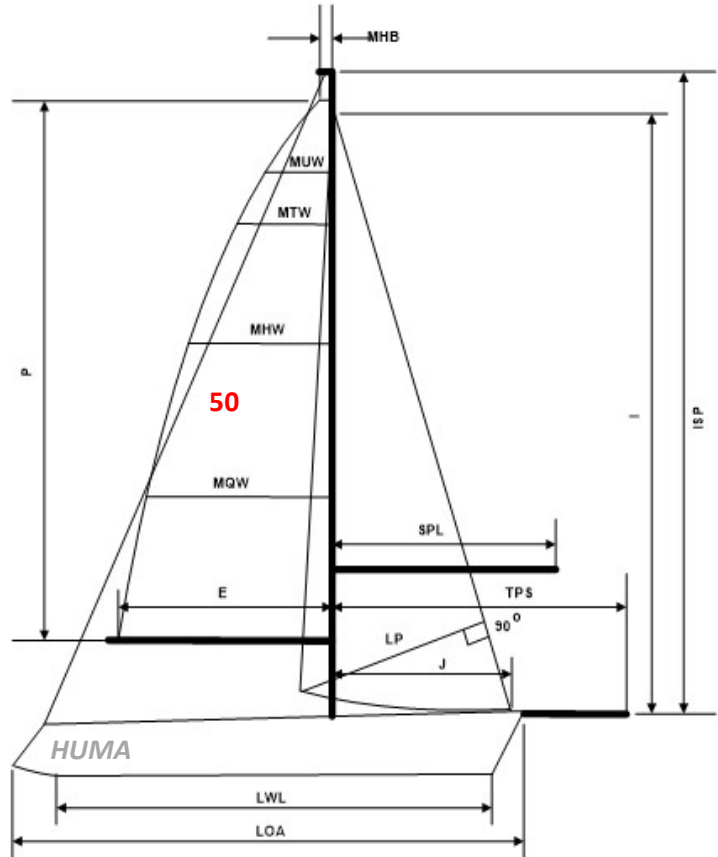

HANDICAP ADJUSTMENTS

+3 RFG / +9 RFM / 100% Asym declared

Adjustments must be requested by the owner and are only made based on visual inspection and/or physical measurement by an authorized PHRF-SS measurer. Fixed Prop credit is for 3-bladed or more fixed prop in aperture or on exposed strut. Asymmetric credit is for an aftermarket sprit pole per Section 20 – Asymmetric Spinnakers. If Asymmetric Credit is given, a symmetrical spinnaker may not be flown at any event designated PHRF-SS. Codes appear in Section 8 - Handicap Adjustments of the PHRF-SS Rules & Bylaws.

Owner Signature: _____

My signature attests to the fact that all the information contained on this certificate is true and correct to the best of my knowledge and that I have not made any modifications to the boat which have not been reported to PHRF-SS.

Certificate Issue: 3/24/2024

Certificate Expires: 3/31/2025



SOUTH SHORE PHRF HANDICAP CERTIFICATE

PHRF-SS, LLC., PO Box 347021, Cleveland, OH 44134

<http://phrfss.org>

HCP (Handicap): 15 sec/nm
JAM (Jib & Main): 25 sec/nm
PPF (Perf Prediction Factor): 1.98
TCF (Time Correction Factor): 1.2655

CREW WEIGHT LIMIT: 2062 LBS.

YACHT NAME: TEAM VANPIRE
DESIGN: MELGES 32 ODR
OWNER: Willem van Heeckeren
CERTIFICATE: **STND**
CLASSIFICATION: HPRF
SAIL NO: 235
POWER: IB
CLUB: EWYC

LOA: 31.83 FT.
LWL: 28.50 FT.
BEAM: 9.83 FT.
DRAFT: 7.00 FT.
DISPLACEMENT: 3774 LBS.
BALLAST: 1570 LBS.
SAIL AREA: 554 SQ. FT.
BASE SPIN: 760 SQ. FT
EST. FORESTAY: 49.40 FT.

I: 39.90 FT.
ISP: 48.20 FT.
J: 10.80 FT.
JSP/TPS: 19.43 FT.
P: 44.00 FT.
E: 15.40 FT.
SADR: 36.68
DLR: 72.78

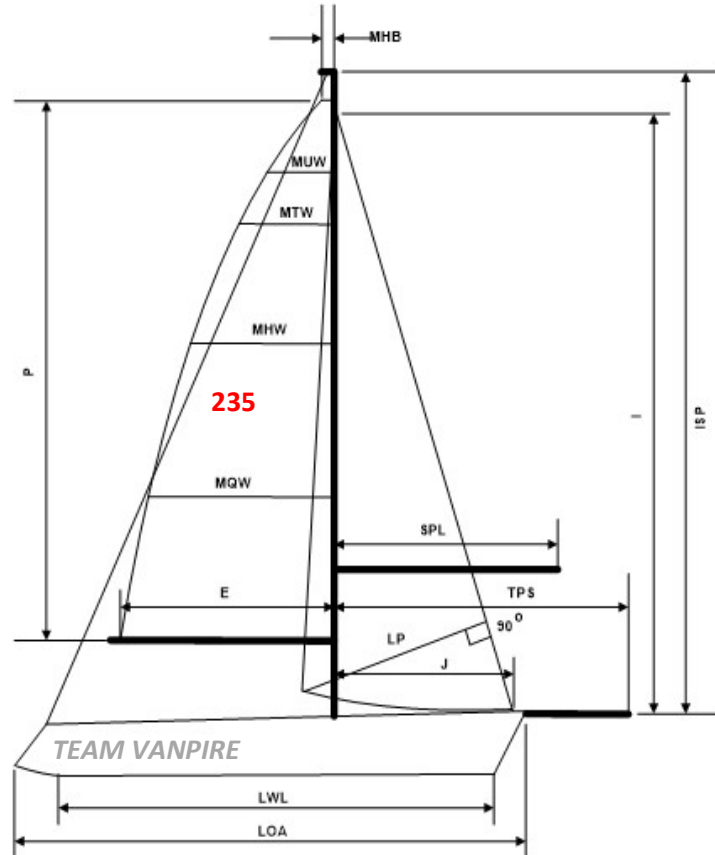

HANDICAP ADJUSTMENTS

104% JIB / 103SQM - 121SQM

Adjustments must be requested by the owner and are only made based on visual inspection and/or physical measurement by an authorized PHRF-SS measurer. Fixed Prop credit is for 3-bladed or more fixed prop in aperture or on exposed strut. Asymmetric credit is for an aftermarket sprit pole per Section 20 – Asymmetric Spinnakers. If Asymmetric Credit is given, a symmetrical spinnaker may not be flown at any event designated PHRF-SS. Codes appear in Section 8 - Handicap Adjustments of the PHRF-SS Rules & Bylaws.

Owner Signature: _____

My signature attests to the fact that all the information contained on this certificate is true and correct to the best of my knowledge and that I have not made any modifications to the boat which have not been reported to PHRF-SS.

Certificate Issue: 3/21/2024

Certificate Expires: 3/31/2025



SOUTH SHORE PHRF HANDICAP CERTIFICATE

PHRF-SS, LLC., PO Box 347021, Cleveland, OH 44134

<http://phrfss.org>

HCP (Handicap): 183 sec/nm
JAM (Jib & Main): 193 sec/nm
PPF (Perf Prediction Factor): 17.06
TCF (Time Correction Factor): 0.9096

CREW WEIGHT LIMIT: 1719 LBS.

YACHT NAME: INTO THE MYSTIC
DESIGN: S2 9.2A
OWNER: Timothy Vining
CERTIFICATE: **STND**
CLASSIFICATION: DSPL
SAIL NO: 25344
POWER: IB
CLUB: EWYC

LOA: 29.92 FT.
LWL: 25.00 FT.
BEAM: 10.25 FT.
DRAFT: 4.92 FT.
DISPLACEMENT: 9800 LBS.
BALLAST: 4000 LBS.
SAIL AREA: 468 SQ. FT.
BASE SPIN: 779 SQ. FT.
EST. FORESTAY: 42.06 FT.

I: 40.00 FT.
ISP: 40.00 FT.
J: 13.00 FT.
JSP/TPS: 13.00 FT.
P: 34.00 FT.
E: 12.25 FT.
SADR: 16.41
DLR: 280.00

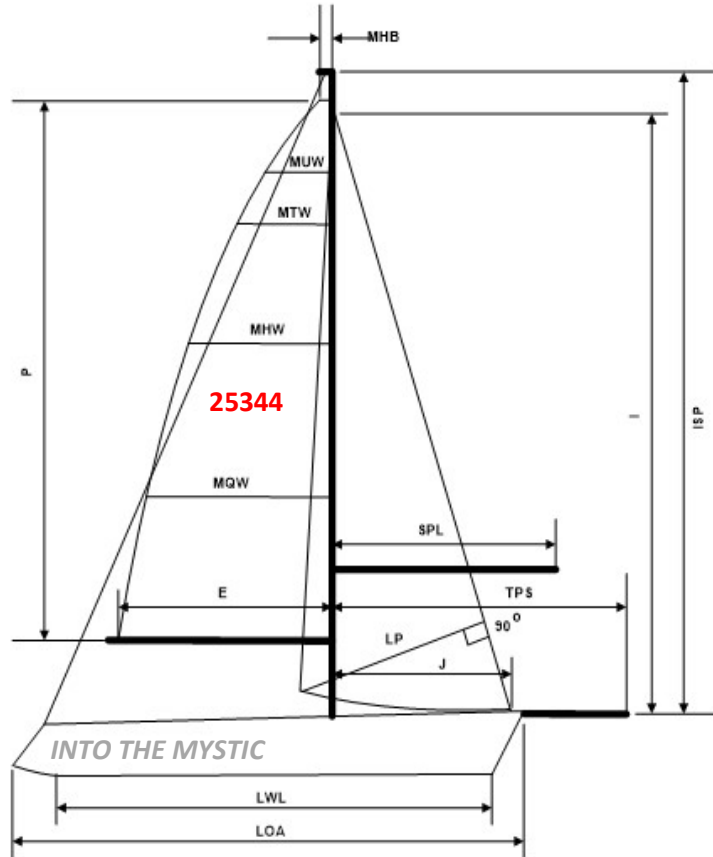

HANDICAP ADJUSTMENTS

3RFG / +6 2BX

Adjustments must be requested by the owner and are only made based on visual inspection and/or physical measurement by an authorized PHRF-SS measurer. Fixed Prop credit is for 3-bladed or more fixed prop in aperture or on exposed strut. Asymmetric credit is for an aftermarket sprit pole per Section 20 – Asymmetric Spinnakers. If Asymmetric Credit is given, a symmetrical spinnaker may not be flown at any event designated PHRF-SS. Codes appear in Section 8 - Handicap Adjustments of the PHRF-SS Rules & Bylaws.

Owner Signature: _____

My signature attests to the fact that all the information contained on this certificate is true and correct to the best of my knowledge and that I have not made any modifications to the boat which have not been reported to PHRF-SS.

Certificate Issue: 5/25/2024

Certificate Expires: 3/31/2025



SOUTH SHORE PHRF HANDICAP CERTIFICATE

PHRF-SS, LLC., PO Box 347021, Cleveland, OH 44134

<http://phrfss.org>

HCP (Handicap): 132 sec/nm
JAM (Jib & Main): 141 sec/nm
PPF (Perf Prediction Factor): 10.67
TCF (Time Correction Factor): 0.9945

CREW WEIGHT LIMIT: 2039 LBS.

YACHT NAME: CAN'T CONTAIN'ER
DESIGN: TARTAN 3500 SD BT
OWNER: Mike Vining
CERTIFICATE: STND
CLASSIFICATION: DSPL
SAIL NO: 91
POWER: IB
CLUB: EWYC

LOA: 35.21 FT.
LWL: 30.00 FT.
BEAM: 11.75 FT.
DRAFT: 4.83 FT.
DISPLACEMENT: 12100 LBS.
BALLAST: 4900 LBS.
SAIL AREA: 615 SQ. FT.
BASE SPIN: 955 SQ. FT.
EST. FORESTAY: 48.73 FT.

I: 46.75 FT.
ISP: 46.75 FT.
J: 13.75 FT.
JSP/TPS: 14.75 FT.
P: 41.25 FT.
E: 14.25 FT.
SADR: 18.74
DLR: 200.07

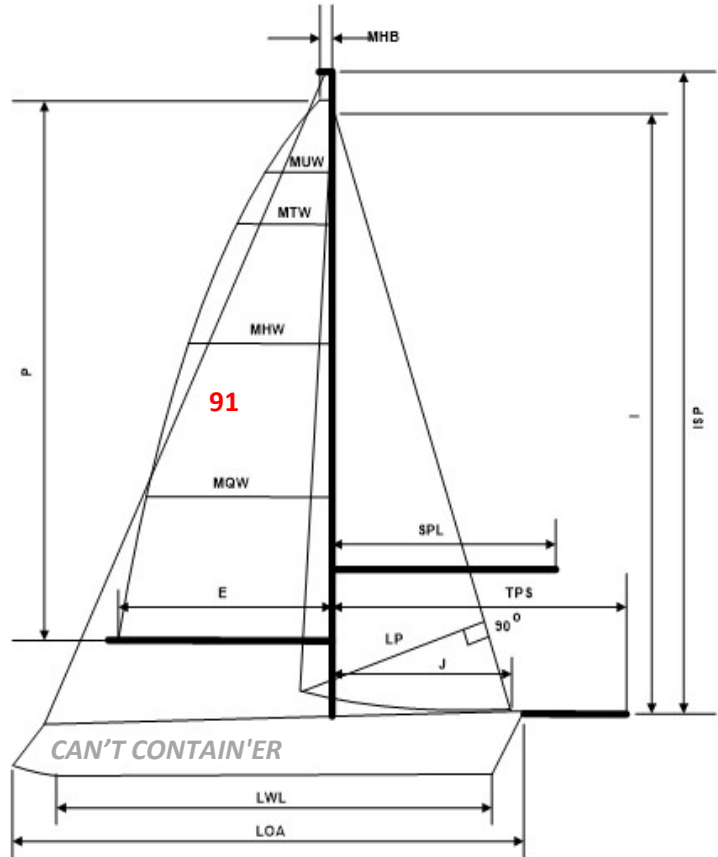

HANDICAP ADJUSTMENTS

+6ASM

Adjustments must be requested by the owner and are only made based on visual inspection and/or physical measurement by an authorized PHRF-SS measurer. Fixed Prop credit is for 3-bladed or more fixed prop in aperture or on exposed strut. Asymmetric credit is for an aftermarket sprit pole per Section 20 – Asymmetric Spinnakers. If Asymmetric Credit is given, a symmetrical spinnaker may not be flown at any event designated PHRF-SS. Codes appear in Section 8 - Handicap Adjustments of the PHRF-SS Rules & Bylaws.

Owner Signature: _____

My signature attests to the fact that all the information contained on this certificate is true and correct to the best of my knowledge and that I have not made any modifications to the boat which have not been reported to PHRF-SS.

Certificate Issue: 4/11/2024

Certificate Expires: 3/31/2025



SOUTH SHORE PHRF HANDICAP CERTIFICATE

PHRF-SS, LLC., PO Box 347021, Cleveland, OH 44134

<http://phrfss.org>

HCP (Handicap): 150 sec/nm
JAM (Jib & Main): 156 sec/nm
PPF (Perf Prediction Factor): 9.58
TCF (Time Correction Factor): 0.9628

CREW WEIGHT LIMIT: 1763 LBS.

YACHT NAME: RUBBER SOUL
DESIGN: J-30
OWNER: Doug Wahl
CERTIFICATE: STND
CLASSIFICATION: DSPL
SAIL NO: 23523
POWER: IB
CLUB: EWYC

LOA: 29.92 FT.
LWL: 25.00 FT.
BEAM: 11.20 FT.
DRAFT: 5.25 FT.
DISPLACEMENT: 6700 LBS.
BALLAST: 2100 LBS.
SAIL AREA: 443 SQ. FT.
BASE SPIN: 591 SQ. FT
EST. FORESTAY: 36.07 FT.

I: 34.00 FT.
ISP: 34.19 FT.
J: 11.50 FT.
JSP/TPS: 12.50 FT.
P: 38.00 FT.
E: 13.00 FT.
SADR: 19.98
DLR: 191.43

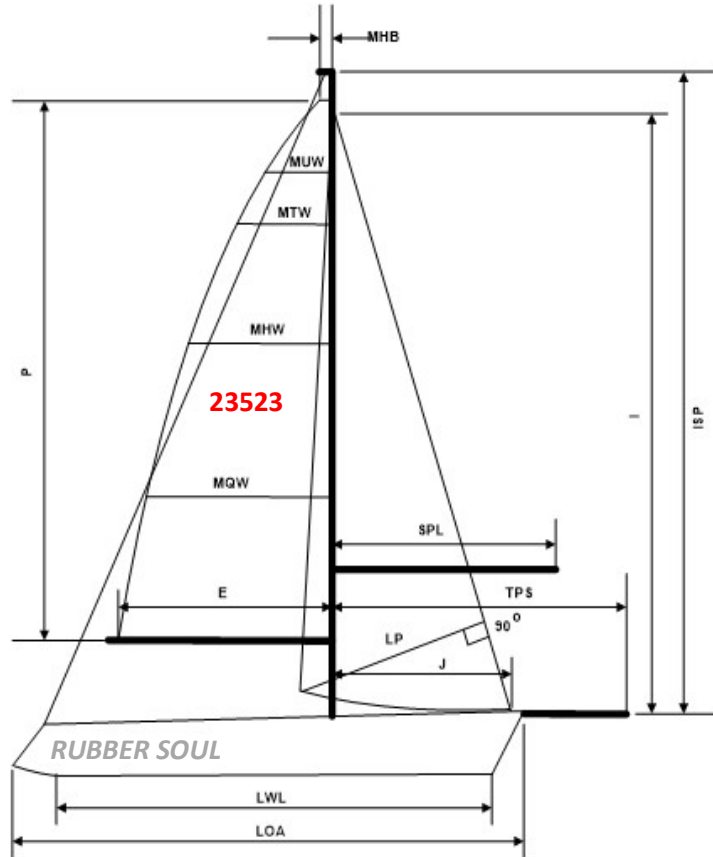

HANDICAP ADJUSTMENTS

+3 RFG

Adjustments must be requested by the owner and are only made based on visual inspection and/or physical measurement by an authorized PHRF-SS measurer. Fixed Prop credit is for 3-bladed or more fixed prop in aperture or on exposed strut. Asymmetric credit is for an aftermarket sprit pole per Section 20 – Asymmetric Spinnakers. If Asymmetric Credit is given, a symmetrical spinnaker may not be flown at any event designated PHRF-SS. Codes appear in Section 8 - Handicap Adjustments of the PHRF-SS Rules & Bylaws.

Owner Signature: _____

My signature attests to the fact that all the information contained on this certificate is true and correct to the best of my knowledge and that I have not made any modifications to the boat which have not been reported to PHRF-SS.

Certificate Issue: 5/26/2024

Certificate Expires: 3/31/2025



SOUTH SHORE PHRF HANDICAP CERTIFICATE

PHRF-SS, LLC., PO Box 347021, Cleveland, OH 44134

<http://phrfss.org>

HCP (Handicap): 138 sec/nm
JAM (Jib & Main): 144 sec/nm
PPF (Perf Prediction Factor): 8.10
TCF (Time Correction Factor): 0.9837

CREW WEIGHT LIMIT: 1908 LBS.

YACHT NAME: GEE WIZ 2
DESIGN: OPTIMA 101 (DEHLER)
OWNER: Mike/Brian Wismer
CERTIFICATE: **STND**
CLASSIFICATION: DSPL
SAIL NO: 40769
POWER: IB
CLUB: FCYC

LOA: 33.14 FT.
LWL: 29.25 FT.
BEAM: 11.15 FT.
DRAFT: 5.58 FT.
DISPLACEMENT: 8511 LBS.
BALLAST: 3968 LBS.
SAIL AREA: 487 SQ. FT.
BASE SPIN: 841 SQ. FT
EST. FORESTAY: 40.47 FT.

I: 38.71 FT.
ISP: 38.71 FT.
J: 11.81 FT.
JSP/TPS: 11.81 FT.
P: 38.39 FT.
E: 13.45 FT.
SADR: 18.74
DLR: 151.83

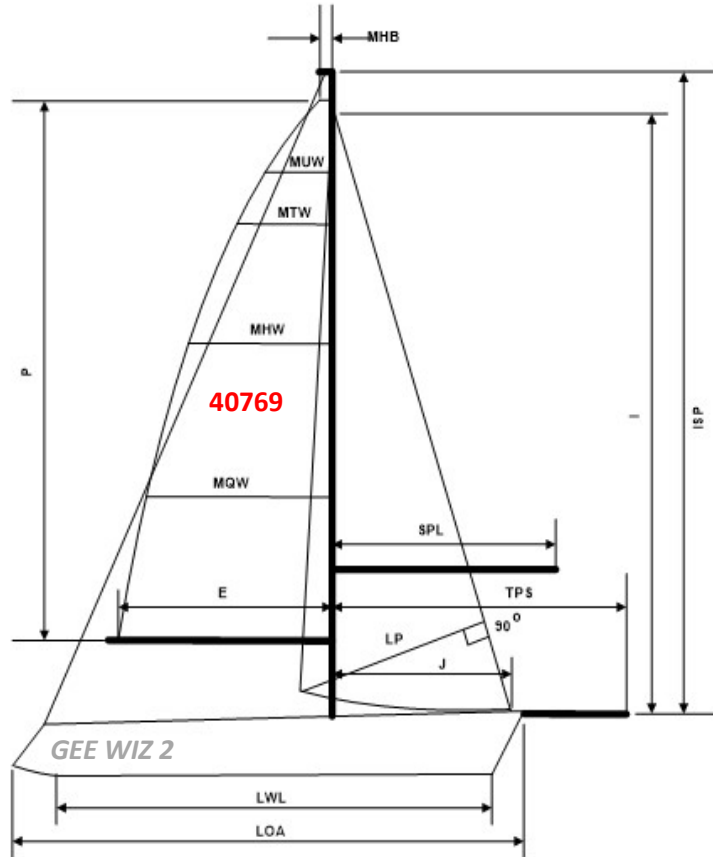

HANDICAP ADJUSTMENTS

+3 RFG

Adjustments must be requested by the owner and are only made based on visual inspection and/or physical measurement by an authorized PHRF-SS measurer. Fixed Prop credit is for 3-bladed or more fixed prop in aperture or on exposed strut. Asymmetric credit is for an aftermarket sprit pole per Section 20 – Asymmetric Spinnakers. If Asymmetric Credit is given, a symmetrical spinnaker may not be flown at any event designated PHRF-SS. Codes appear in Section 8 - Handicap Adjustments of the PHRF-SS Rules & Bylaws.

Owner Signature: _____

My signature attests to the fact that all the information contained on this certificate is true and correct to the best of my knowledge and that I have not made any modifications to the boat which have not been reported to PHRF-SS.

Certificate Issue: 5/26/2024

Certificate Expires: 3/31/2025



SOUTH SHORE PHRF HANDICAP CERTIFICATE

PHRF-SS, LLC., PO Box 347021, Cleveland, OH 44134

<http://phrfss.org>

HCP (Handicap): 48 sec/nm
JAM (Jib & Main): 58 sec/nm
PPF (Perf Prediction Factor): 6.98
TCF (Time Correction Factor): 1.1752

CREW WEIGHT LIMIT: 2393 LBS.

YACHT NAME: VIVA LA VIDA
DESIGN: J-120 AL ODR
OWNER: Tim Yanda
CERTIFICATE: **ODR**
CLASSIFICATION: DSPL
SAIL NO: 46722
POWER: IB
CLUB: EWYC

LOA: 40.00 FT.
LWL: 34.50 FT.
BEAM: 12.00 FT.
DRAFT: 7.00 FT.
DISPLACEMENT: 13900 LBS.
BALLAST: 6000 LBS.
SAIL AREA: 780 SQ. FT.
BASE SPIN: 1115 SQ. FT.
EST. FORESTAY: 53.98 FT.

I: 50.50 FT.
ISP: 52.00 FT.
J: 14.50 FT.
JSP/TPS: 21.50 FT.
P: 46.50 FT.
E: 17.80 FT.
SADR: 21.66
DLR: 151.12

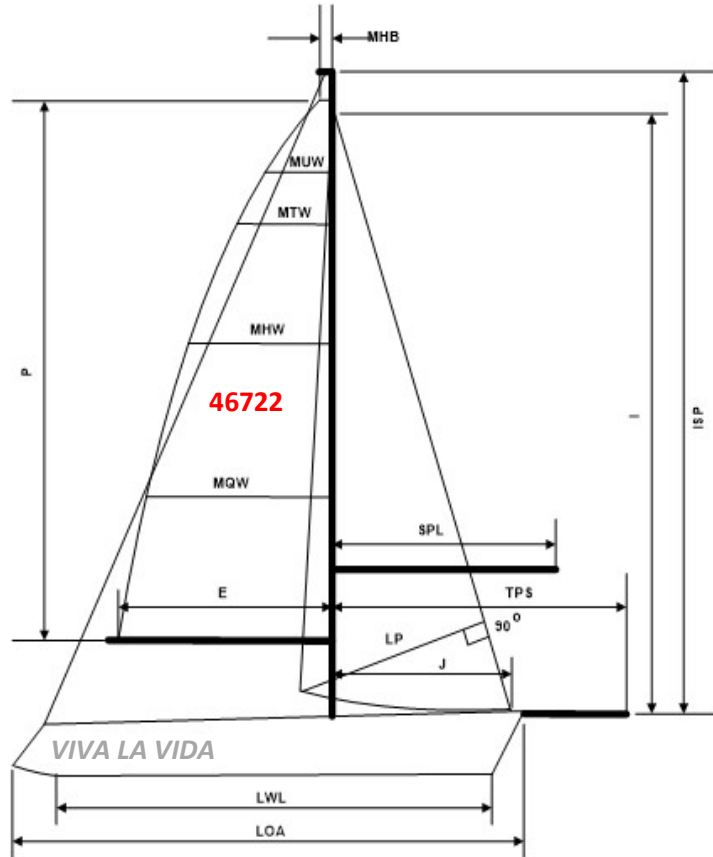

HANDICAP ADJUSTMENTS

Adjustments must be requested by the owner and are only made based on visual inspection and/or physical measurement by an authorized PHRF-SS measurer. Fixed Prop credit is for 3-bladed or more fixed prop in aperture or on exposed strut. Asymmetric credit is for an aftermarket sprit pole per Section 20 – Asymmetric Spinnakers. If Asymmetric Credit is given, a symmetrical spinnaker may not be flown at any event designated PHRF-SS. Codes appear in Section 8 - Handicap Adjustments of the PHRF-SS Rules & Bylaws.

Owner Signature: _____

My signature attests to the fact that all the information contained on this certificate is true and correct to the best of my knowledge and that I have not made any modifications to the boat which have not been reported to PHRF-SS.

Certificate Issue: 2/28/2024

Certificate Expires: 3/31/2025



SOUTH SHORE PHRF HANDICAP CERTIFICATE

PHRF-SS, LLC., PO Box 347021, Cleveland, OH 44134

<http://phrfss.org>

HCP (Handicap): 39 sec/nm
JAM (Jib & Main): 51 sec/nm
PPF (Perf Prediction Factor): 5.02
TCF (Time Correction Factor): 1.1985

CREW WEIGHT LIMIT: 2230 LBS.

YACHT NAME: BLACK SEAL
DESIGN: J-111
OWNER: Seth Young
CERTIFICATE: ODR
CLASSIFICATION: DSPL
SAIL NO: 111
POWER: IB
CLUB: LYC

LOA: 36.42 FT.
LWL: 32.71 FT.
BEAM: 10.80 FT.
DRAFT: 7.18 FT.
DISPLACEMENT: 9370 LBS.
BALLAST: 3516 LBS.
SAIL AREA: 659 SQ. FT.
BASE SPIN: 1047 SQ. FT.
EST. FORESTAY: 53.07 FT.

I: 47.74 FT.
ISP: 51.23 FT.
J: 13.85 FT.
JSP/TPS: 21.33 FT.
P: 45.24 FT.
E: 14.50 FT.
SADR: 23.79
DLR: 119.52

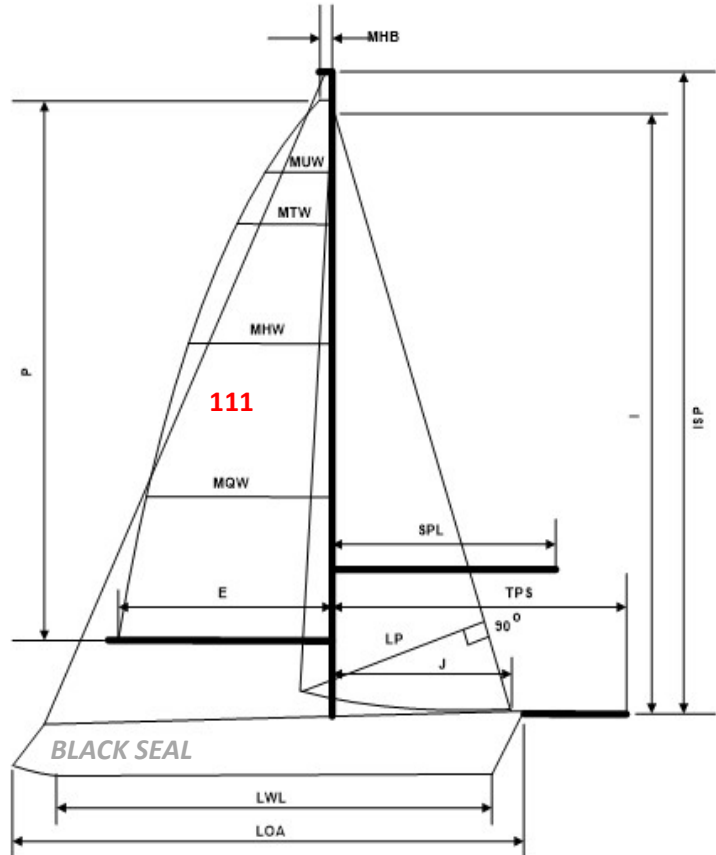

HANDICAP ADJUSTMENTS

106% JIB, 130 SQM (1399 SQ. FT)

Adjustments must be requested by the owner and are only made based on visual inspection and/or physical measurement by an authorized PHRF-SS measurer. Fixed Prop credit is for 3-bladed or more fixed prop in aperture or on exposed strut. Asymmetric credit is for an aftermarket sprit pole per Section 20 – Asymmetric Spinnakers. If Asymmetric Credit is given, a symmetrical spinnaker may not be flown at any event designated PHRF-SS. Codes appear in Section 8 - Handicap Adjustments of the PHRF-SS Rules & Bylaws.

Owner Signature: _____

My signature attests to the fact that all the information contained on this certificate is true and correct to the best of my knowledge and that I have not made any modifications to the boat which have not been reported to PHRF-SS.

Certificate Issue: 4/14/2024

Certificate Expires: 3/31/2025