

BENDIX PS SERIES CARBURETOR MANUAL

- **OPERATION**
- **INSTALLATION**
- **ADJUSTMENT**
- **SERVICE**

APRIL 1, 1976

**THE BENDIX CORPORATION
ENERGY CONTROLS DIVISION
717 N. BENDIX DRIVE
SOUTH BEND, INDIANA 46620**

Copyright © 1956, 1959, 1967, 1976
The Bendix Corporation
South Bend, Indiana 46620 U. S. A.



FOREWORD

This service manual has been prepared and distributed by the Product Support Publications Department of the Energy Controls Division of The Bendix Corporation and is intended for use by service personnel responsible for the installation, adjustment, and maintenance of the PS Series Carburetors. Every effort has been made to include specific carburetor instructions for each current model aircraft and engine incorporating a PS type carburetor. If any manufacturer, certain model aircraft or specific engine has been omitted, it is because the necessary information was not available at the time of printing.

This manual is to be revised periodically so that maintenance personnel will be informed of the latest service procedures and modifications. If, in the opinion of any reader, certain information or procedures have been omitted, an endeavor will be made to include such information in future revisions by directing your comments and suggestions to the above office.

TABLE OF CONTENTS

	INTRODUCTION	3
SECTION I	- DESCRIPTION	3
	General	6
	Model Designation	8
SECTION II	- PRINCIPLES OF OPERATION	
	General	11
	Air Section	11
	Fuel Section	12
	Acceleration Pump	15
	Manual Mixture Control	16
	Idle Cut-Off	17
	Airflow Power Enrichment Valve	17
	Automatic Mixture Control Assembly	19
SECTION III	- INSTALLATION	
	Engine	21
	Air Scoop	22
	Fuel Systems and Connections	26
	Throttle and Mixture Control Levers	27
	Preparation for Use	28
SECTION IV	- FIELD ADJUSTMENTS	
	Idle Speed and Mixture Adjustment	30
	Enrichment Valve Adjustment	32
	Discharge Nozzle (Metered Fuel Pressure) Adjustment	35
SECTION V	- MAINTENANCE, LUBRICATION AND PREPARATION FOR STORAGE	
	Maintenance	40
	Lubrication	42
	Preparation for Storage	42
SECTION VI	- GROUND AND FLIGHT, CARBURETOR NOTES	
	Induction System Icing	44
	Vaporization Icing	44
	Atmospheric Icing	44
	Rain	44
	Ice and Snow	45
	Flight Notes on the Automatic Mixture Control and Airflow Enrichment Valve	45

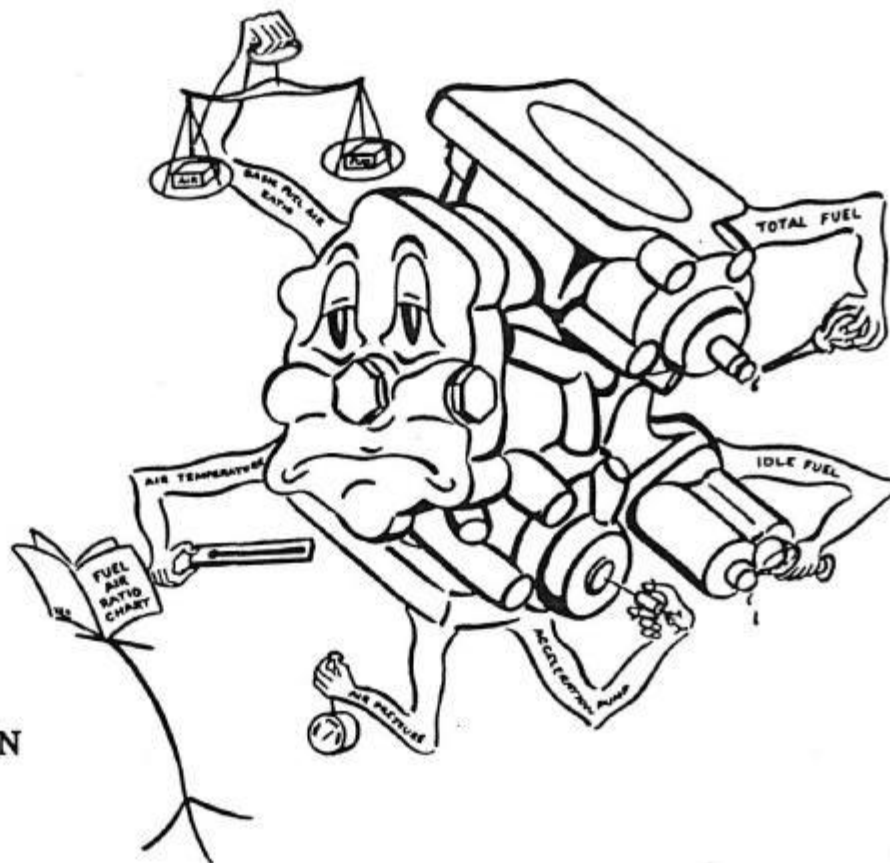

INTRODUCTION

Carburetion as applied to the modern aircraft reciprocating engine presents one of the most complex and difficult problems of engine development and operation. If the engine is not supplied with just the right fuel-air ratio under all conditions of flight, the performance will of course, be affected, and in some cases severe damage to the engine may result. The modern aircraft carburetor must maintain the proper fuel-air ratio for the engine at all conditions of air pressure and temperature, throttle opening, engine speed, flight attitude, acceleration and maneuvers. It must supply a mixture in the idle range that is rich enough to give smooth idling, yet lean enough to prevent the engine from loading up. In the cruise range the mixture is usually held as lean as possible to afford good fuel economy. In the high power range a rich mixture is necessary to both inhibit detonation and to decrease the amount of air cooling necessary.

As a result, the aircraft carburetor has become a highly developed and complicated mechanism which is very accurate. It should be considered a precision instrument and treated as such, for it is manufactured with extreme care. To obtain the maximum in performance and service, the carburetor must be installed and adjusted in accordance with the manufacturer's recommendations.

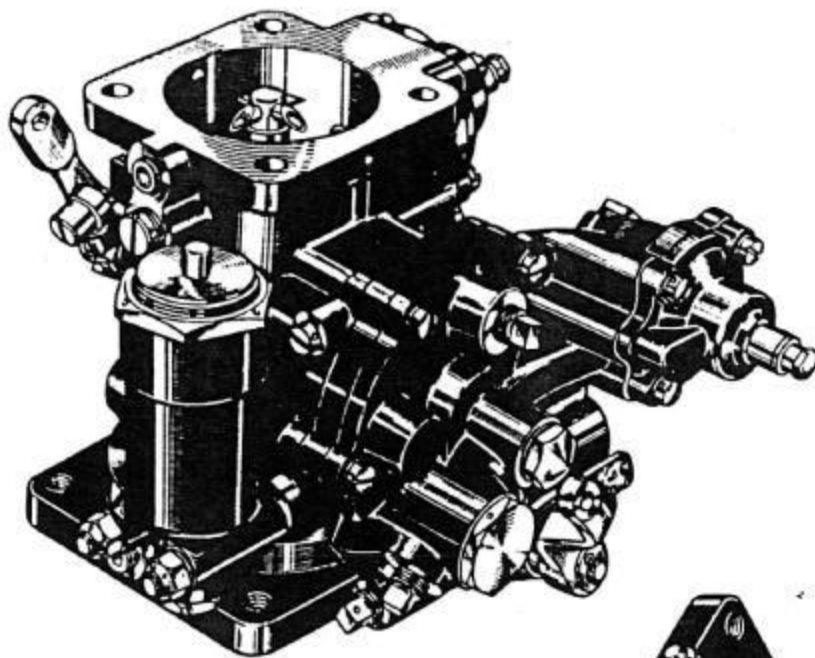

PS - 5BD

PSH - 5BD

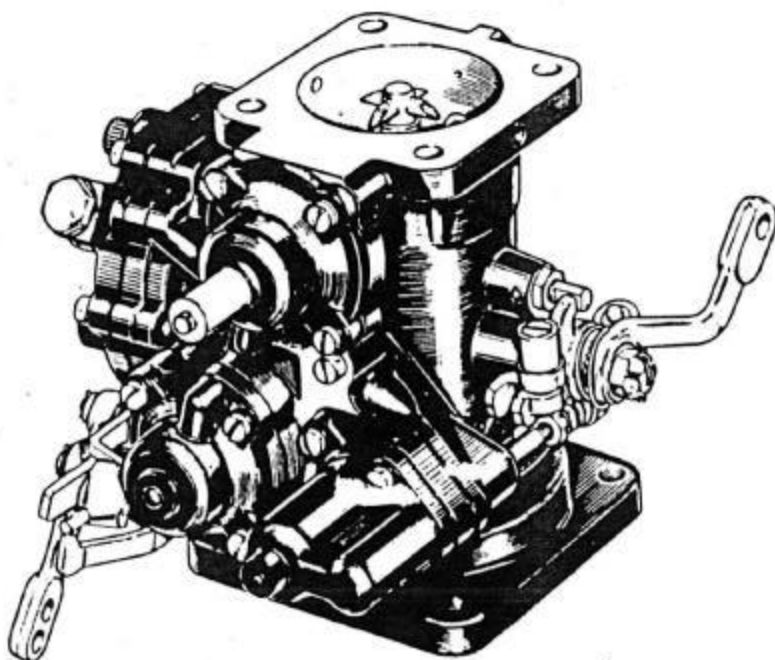
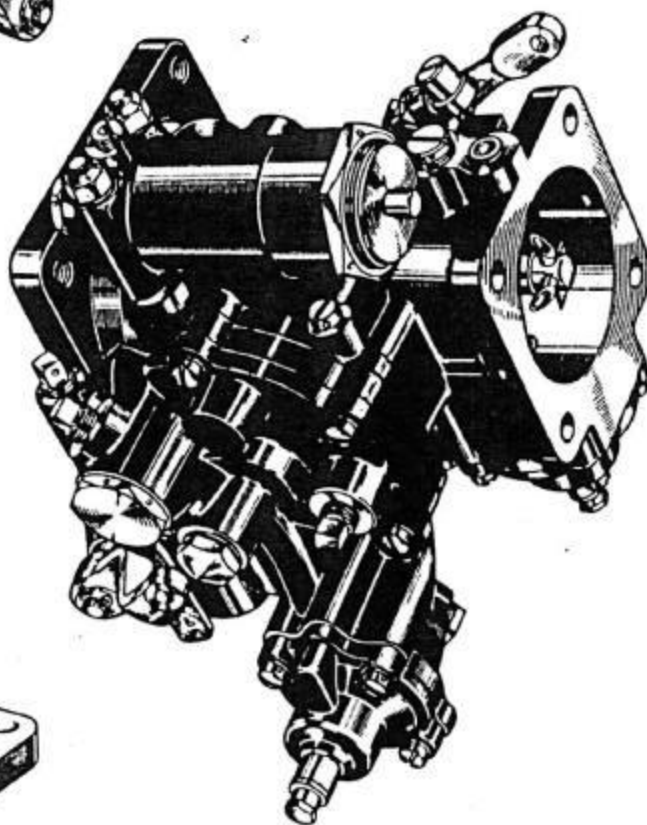

PS - 5C

PS - 7BD

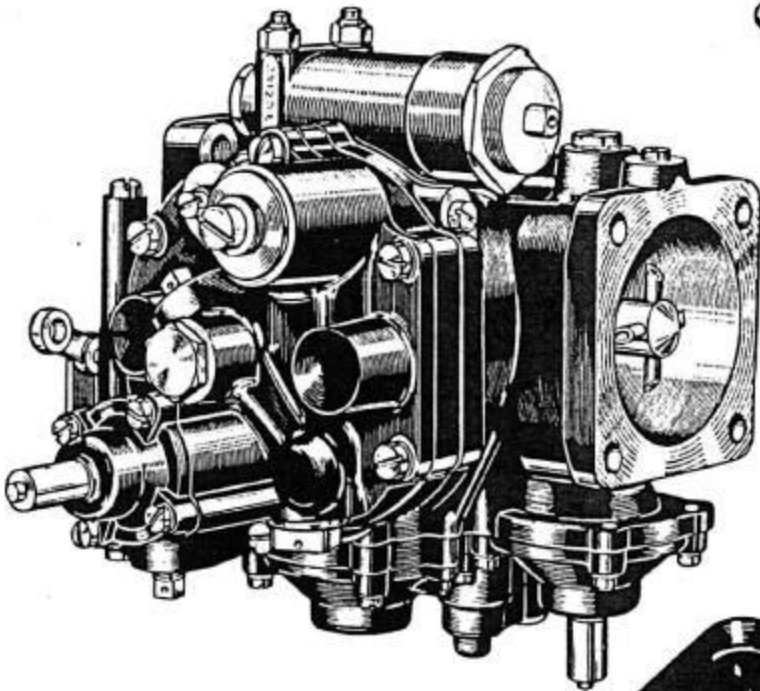
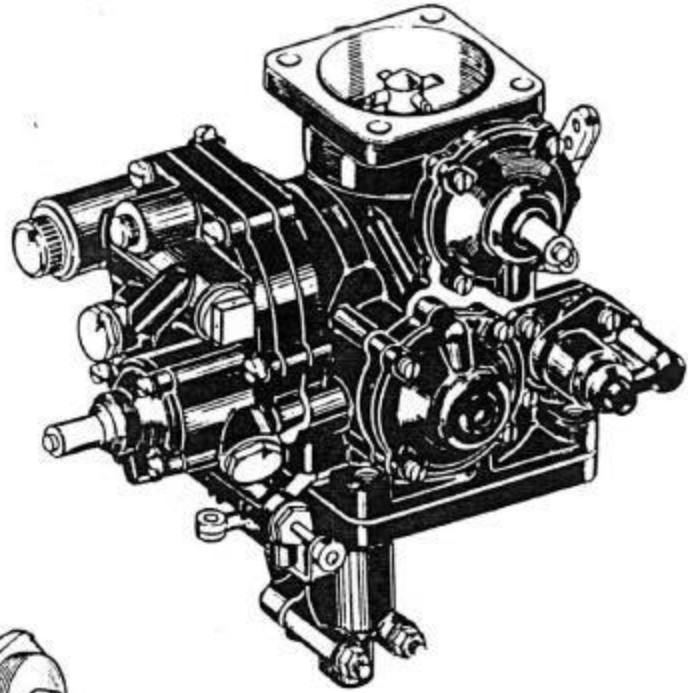

PSH - 7BD

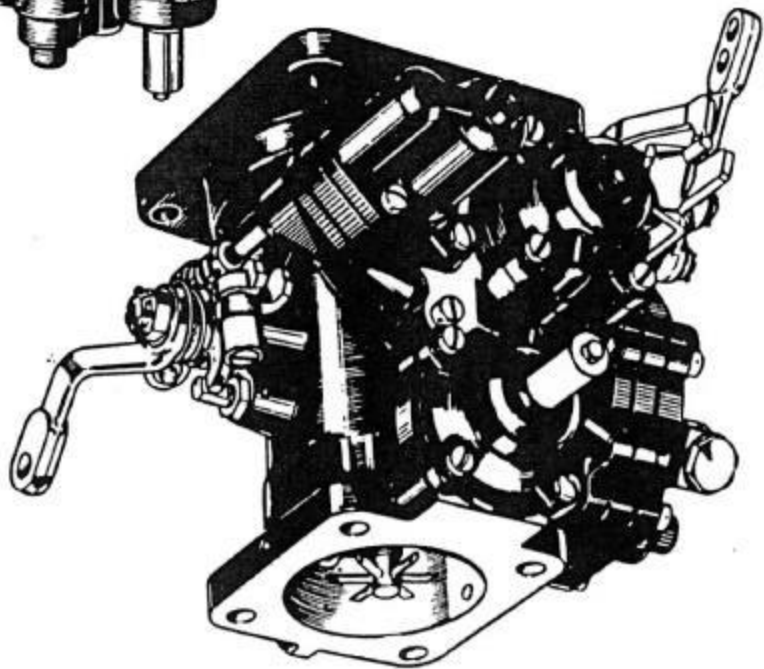

PSD - 5C

SECTION I

DESCRIPTION

GENERAL



1-1. The Stromberg PS series injection carburetors are distinctly different from float type carburetors of the same size and power range, as they do not incorporate a vented float chamber or suction pickup from a discharge nozzle in the venturi tube. Instead they offer a pressure fed fuel system that is closed from the engine fuel pump to the discharge nozzle. The venturi serves only to create pressure differentials for controlling the quantity of fuel to the metering jet in proportion to air flow to the engine. This type of fuel system offers such advantages as:

a. The discharge nozzle is located downstream from the throttle valve, ice formation within the throttle body is eliminated.



b. Freedom from gravity effects; maintains proper fuel/air ratios regardless of aircraft attitude.

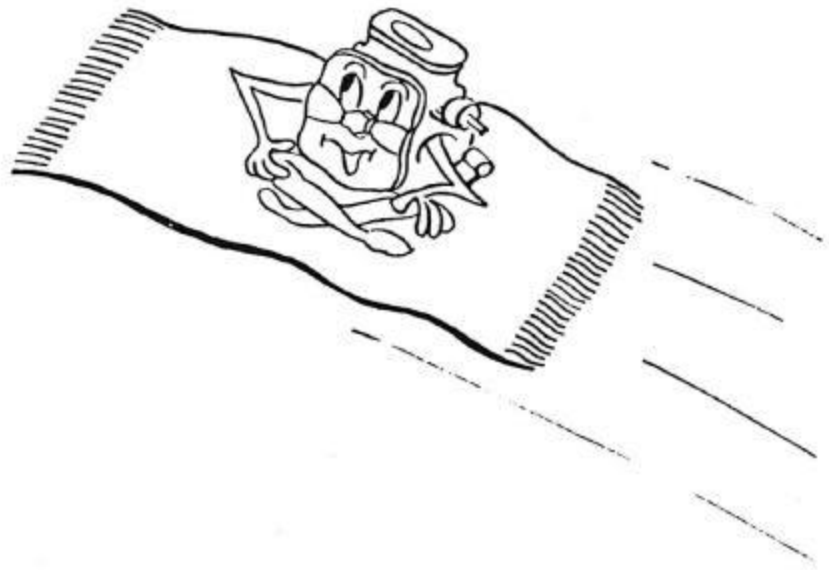

c. Automatic compensation for temperature and altitude.

d. Accurate predictability of fuel consumption.



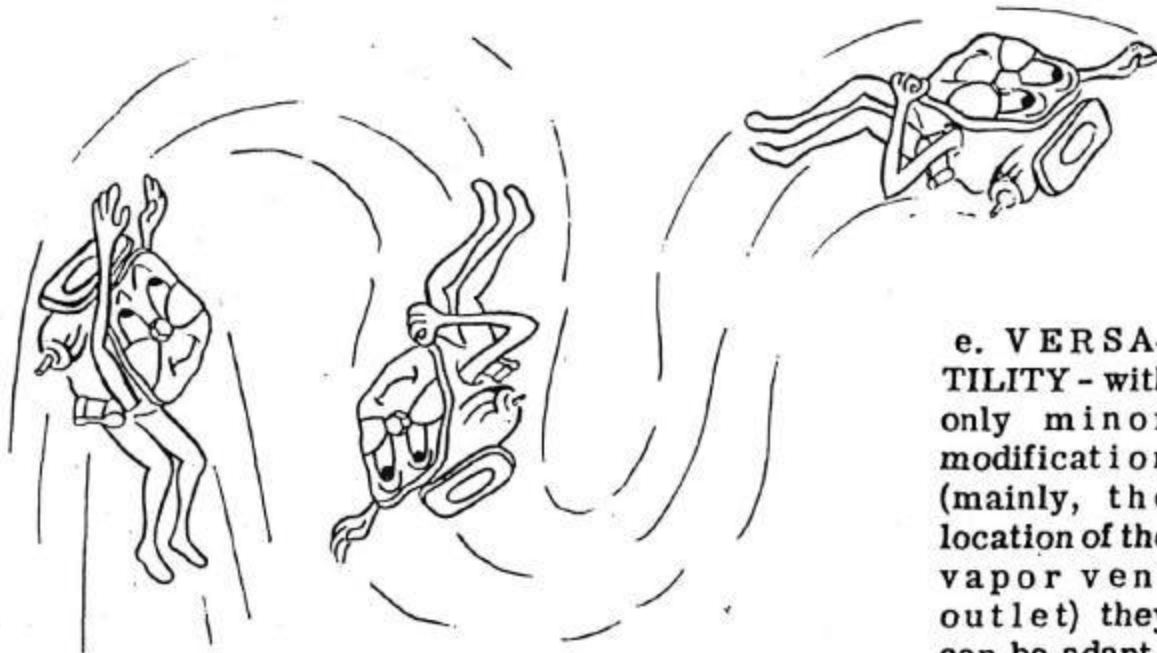

e. VERSATILITY - with only minor modification (mainly, the location of the vapor vent outlet) they can be adapted

ed for either updraft, downdraft or horizontal operation.

1-2. The standard PS carburetor features a regulated pressure discharge nozzle, vacuum operated acceleration pump, manual mixture and idle cut-off device, and either an airflow or manually operated power enrichment valve. Models are also available incorporating an Automatic Mixture Control Unit and an Electric Primer Assembly.

MODEL DESIGNATION

1-3. The model designation such as PS-5C, PS-5BD, etc., indicate the various features of that particular model carburetor. One should learn to recognize the various models by their proper prefix designations as follows:

a. Prefix:

- "P" - Pressure operated
- "S" - Single Barrel
- "D" - Downdraft
- "H" - Horizontal



b. The number following the dash, such as -5, -7, or -9 indicate the bore size of the carburetor and is used for engineering information only, as when matching a carburetor to a particular engine.

c. Sub-Model designation:

“B” - Airflow operated power enrichment valve

“C” - Manually controlled power enrichment valve

“D” - Automatic Mixture Control Unit

“E” - Electric Primer Assembly

“F” - Fuel Head Enrichment Valve

d. Examples:

PS-5C, Pressure operated, single barrel, updraft carburetor, incorporating a manually operated power enrichment valve.

PS-5BD, Pressure operated, single barrel, updraft carburetor, incorporating an airflow operated enrichment valve and an Automatic Mixture Control Unit.

PSH-5CD, Pressure operated, single barrel, horizontal carburetor, incorporating a manually operated power enrichment valve and an Automatic Mixture Control Unit.

PSD-5C, Pressure operated, single barrel, downdraft carburetor, incorporating a manually operated power enrichment valve.

PSH-7DF, Pressure operated, single barrel horizontal carburetor, incorporating an Automatic Mixture Control Unit, a fuel pressure operated enrichment valve and a two position mixture control.

1-4. Each new carburetor is identified with a specification plate (figure 1), attached to the throttle body. It identifies the carburetor manufacturer, unit serial number, model designation and parts list and issue number to which the carburetor was manufactured. Always refer to the specification plate for the proper model and

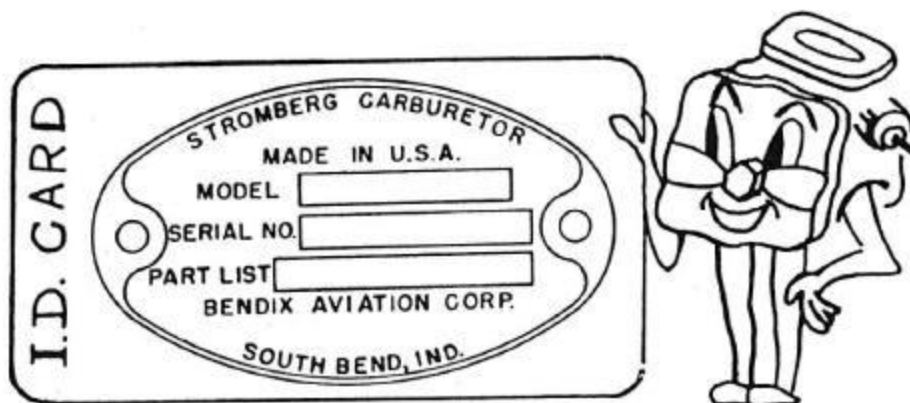

Figure 1. Specification Plate

parts list number to which the carburetor was built, before attempting any field adjustments. This information must then be matched with the correct manual enrichment adjusting gage, and adjustment instructions for that particular carburetor as outlined in the text.

SECTION II

PRINCIPLES OF OPERATION

GENERAL

2-1. This section is arranged to acquaint the reader with the basic principles of operation of the "PS" series carburetors. For clarity and ease of presentation, the air and fuel circuits are traced separately. For aid in tracing the various circuits, refer frequently to the schematic diagram of the PSH-7BD, located the center of the book. This is used as an example as it best represents the latest "PS" type carburetor.



2-2. Following the review of the complete carburetor is a description of the Air Flow Power Enrichment Valve and the Automatic Mixture Control.

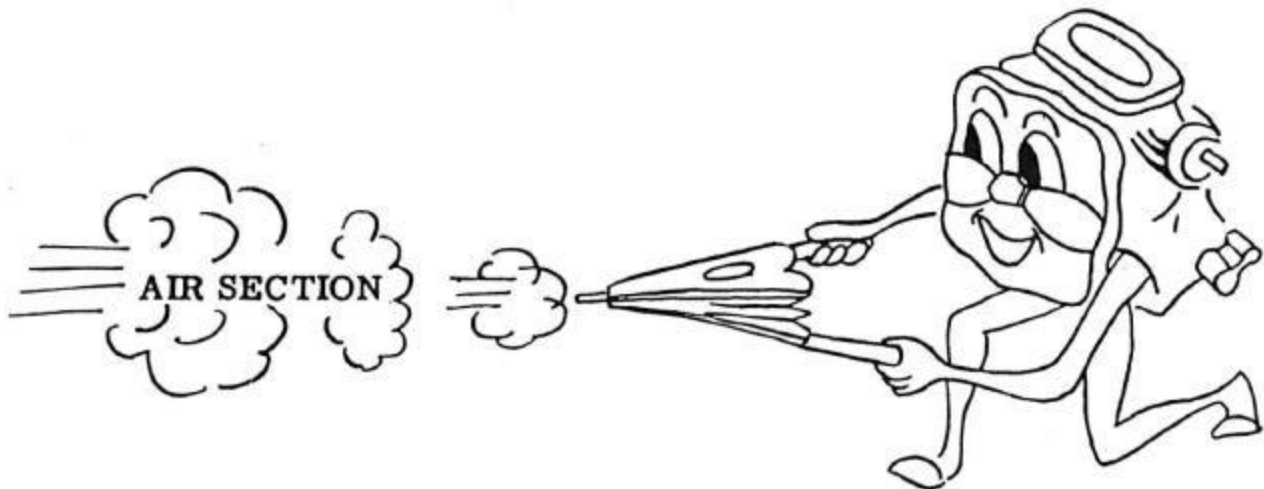

2-3. Air enters the carburetor through the air intake, passes through the venturi tube, past the throttle valve, and into the intake manifolds. The flow of air is controlled by a conventional butterfly type throttle valve. Air flowing through the venturi creates a suction at the throat of the venturi tube. This suction is transmitted through internal channels to chamber "B" of the regulator, and to the low pressure side of the discharge nozzle diaphragm. This suction is termed "venturi suction".

a. Intake air also enters the annular space between the outside diameter of the venturi tube and the flange of the carburetor main body and flows through internal channels to chamber "A" of the regulator and to the discharge nozzle air bleeder. This pressure is termed "impact pressure".

b. As the "impact pressure" in chamber "A" is greater than the "venturi suction" in chamber "B", a pressure differential is created acting upon the air diaphragm separating the two chambers. This differential force acting on the air diaphragm is termed "metering suction", which increases and decreases with the air flow through the carburetor.

c. Movement of the air diaphragm in response to "metering suction", is applied to the regulator needle (poppet) valve through a stem arrangement. The degree of opening of this valve determines the pressure of unmeasured fuel that is applied to the metering jet.

FUEL SECTION

2-4. Fuel at engine pump pressure, flows through the fuel strainer in chamber "E" and past the poppet valve into chamber "D" of the regulator. The pressure of the fuel in chamber "D" is lower than that in chamber "E" due to the pressure drop across the poppet valve. Fuel at this pressure is termed "unmetered fuel". The pressure of the fuel in chamber "D" is regulated by the opening of the poppet valve..



a. In the idle range, at low air flows, there is little or no "venturi suction" available, so the regulator spring force in chamber "A" acting on the poppet valve will be opposed by the unmetered fuel pressure in chamber "D". These two opposing forces are so balanced as to hold the poppet valve open sufficiently to allow an ample amount of fuel to pass for idling purposes.

b. After passing through the main metering jet, fuel is next exposed to the idle needle valve and its respective diaphragm. This fuel pressure acting on the diaphragm will force the idle needle valve away from its seat. This movement, however, is restricted and controlled by a fork on the throttle lever. At this point in the operating range the actual metering of fuel is accomplished by the idle needle valve, as the orifice created by this valve and its seat is smaller than the orifice in the main metering jet.

c. On carburetors equipped with the manually controlled power enrichment valve the idle needle is of the "step design" having two major diameters, the larger controls fuel flows to approximately 25% power, the smaller diameter controls fuel flows from the 25% power range to about 65% power, (cruise range). See figures 2 and 3 for details of typical idle needles used in the "PS" type carburetors.

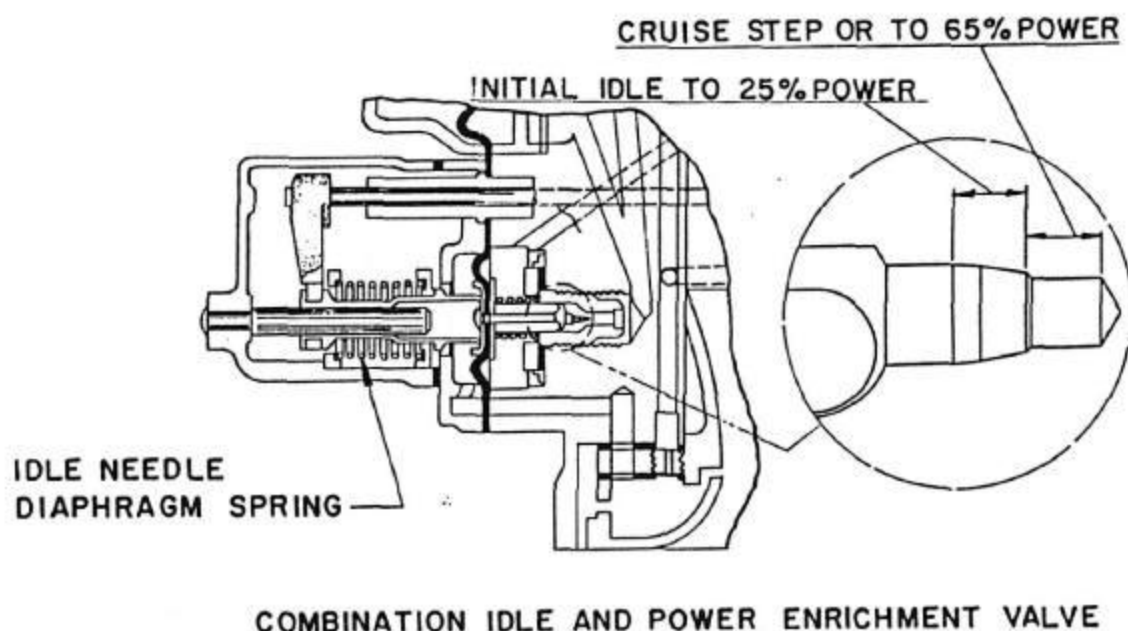

Figure 2. Typical "C" Idle Needle and Power Enrichment Needle

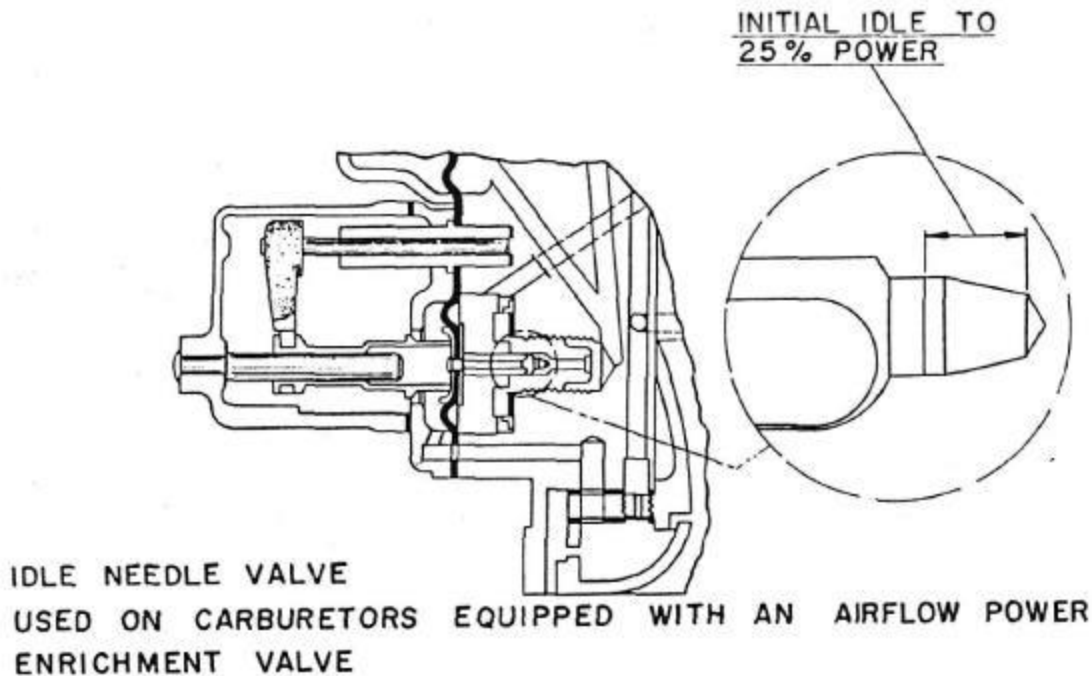

Figure 3. Typical "BD" Idle Needle

d. As the throttle lever is opened, the fork on the throttle lever will move out of contact with the idle push rod and allow the spring pressure acting on the diaphragm to hold the idle needle valve on the cruise step during the cruise range. As the throttle lever approaches a predetermined position (approximately 1/2 throttle), the enrichment needle actuating screw (on the loose lever) contacts the idle push rod so any further movement of the throttle lever will cause the idle push rod to move in a direction that will release the diaphragm spring pressure. This will allow the metered fuel pressure acting on the idle needle valve diaphragm to move the cruise step portion of the needle out of the idle seat, thereby mechanically furnishing the necessary enrichment for maximum cruise powers, climb and full throttle operation.

e. After passing through the idle needle and power enrichment valve seat, metered fuel pressure flows to the fuel side of the discharge nozzle diaphragm, see figure 4. This diaphragm controls the discharge nozzle needle valve position. The opposite side of the diaphragm is exposed to venturi suction, and an adjustable spring. When metered fuel pressure on the fuel side of the diaphragm overcomes this spring pressure the needle valve will open and allow fuel to discharge through the nozzle seat and out the discharge nozzle under positive pressure.

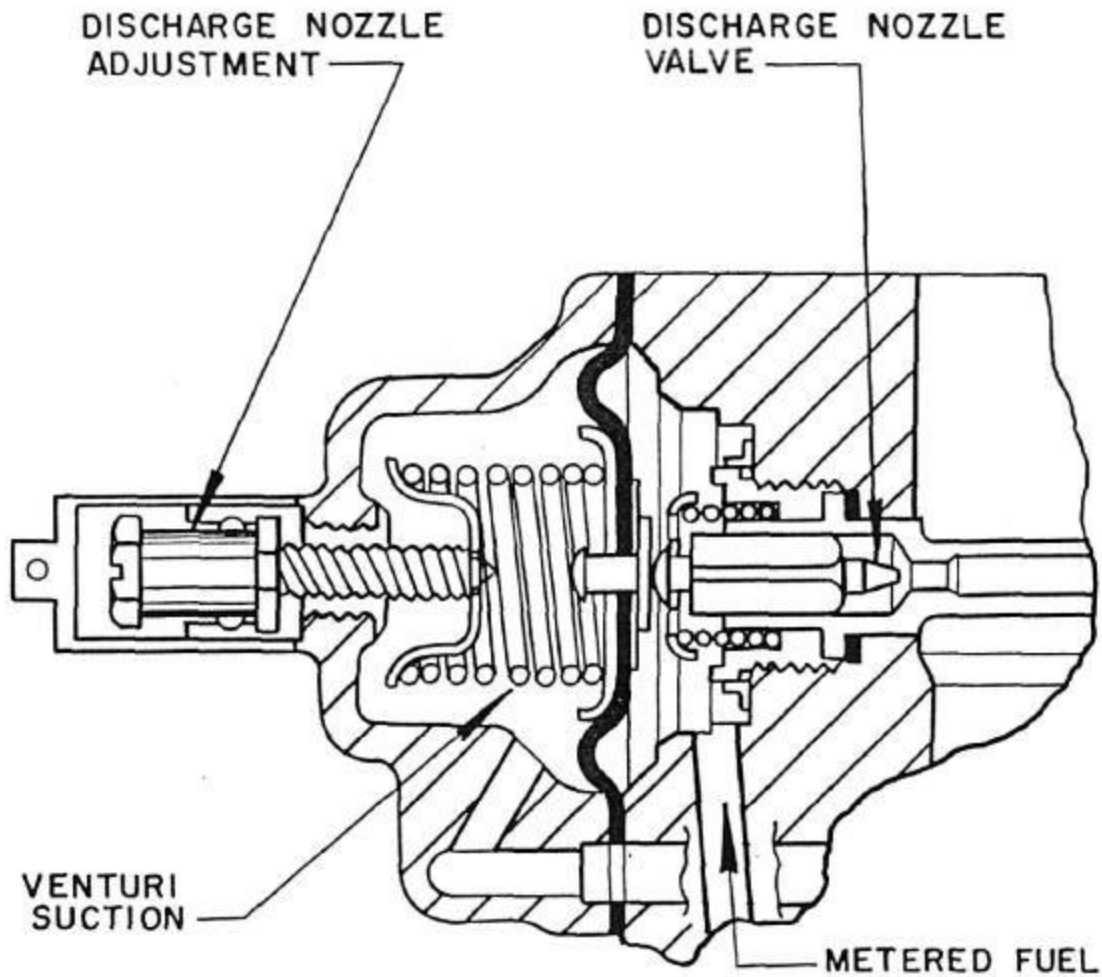

Figure 4. Details of the Discharge Nozzle Assembly

ACCELERATION PUMP

2-5. The "PS" series carburetors are equipped with a single diaphragm, vacuum operated, acceleration pump that compensates for the lag in fuel flows that occur



when the throttle is opened rapidly. The pump is composed of a vacuum chamber, diaphragm and fuel well. (On some models a spacer is installed between the fuel well and the metered fuel channel. The spacer will contain an inlet passage or bleed and a discharge relief valve to give a time delay action to the acceleration

pump discharge.) The vacuum side of the diaphragm contains a spring and is exposed to pressure above the throttle (approximately equal to intake manifold suction), while the fuel well on the opposite side of the diaphragm is open to "metered fuel pressure". The pressure differential will cause the diaphragm to move in a direction that will compress the spring and at the same time fill the now enlarged pump well with fuel. When the throttle is opened quickly, pressure above the throttle will increase as will the pressure on the air side of the diaphragm. This increase in pressure plus the spring force will move the diaphragm toward the pump well, displacing the fuel in the pump well. This discharged fuel will increase the pressure on the discharge nozzle diaphragm, causing the nozzle needle valve to open farther and provide a momentary rich mixture.

MANUAL MIXTURE CONTROL

2-6. A manual mixture control valve is provided as a means of correcting for natural enrichment at altitude on carburetors without Automatic Mixture Control Unit. It consists of a needle valve and seat that form an adjustable bleed between chamber A and chamber B. In operation, as the aircraft gains altitude, a wider throttle opening will be necessary to maintain ground level power. But as venturi suction increases with throttle opening, a rich mixture will result. The pilot can then adjust the manual mixture control valve to bleed off the excess venturi suction and maintain the correct fuel-air ratio.



IDLE CUT-OFF

2-7. When the manual mixture control lever is moved to the idle cut-off position, a cam on the linkage actuates a rocker arm which

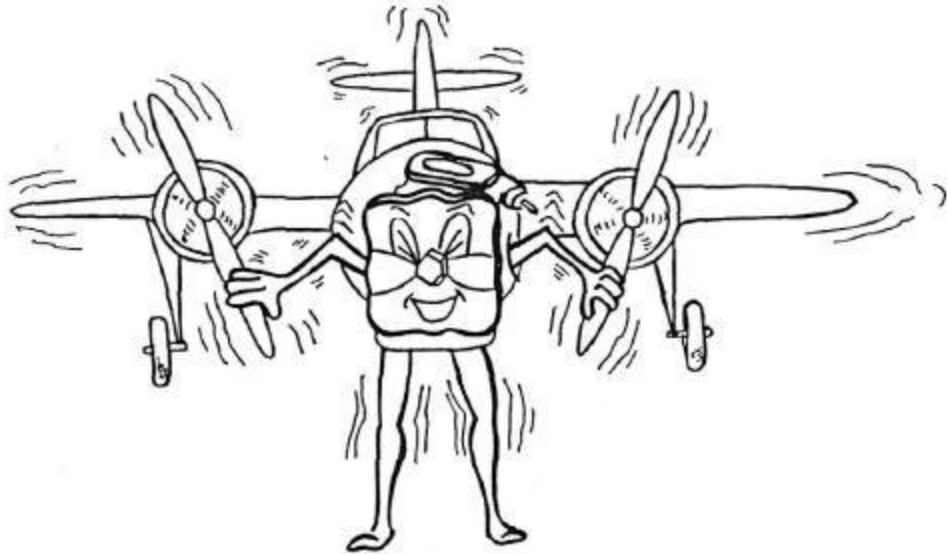

causes the idle cut-off plunger to move inward against the release lever in chamber "A". The lever compresses the regulator diaphragm spring to release all tension on the diaphragm between chambers "A" and "B". This permits fuel pressure plus regulator needle (poppet) valve spring force to close the poppet valve and stop the fuel flow through the carburetor. It should also be noted that placing the mixture control lever in idle cut-off will position the mixture control needle off of its seat and allow metering suction within the carburetor to bleed off.

AIRFLOW POWER ENRICHMENT VALVE

2-8. The airflow power enrichment valve, when used, consists of a spring loaded, diaphragm operated, metering valve. One side of the diaphragm is exposed to unmetered fuel pressure, and the other side to "venturi suction" plus an adjustable spring. When the pressure differential across the diaphragm establishes a force strong enough to compress the spring, the valve will open and supply an additional amount of fuel to the metered

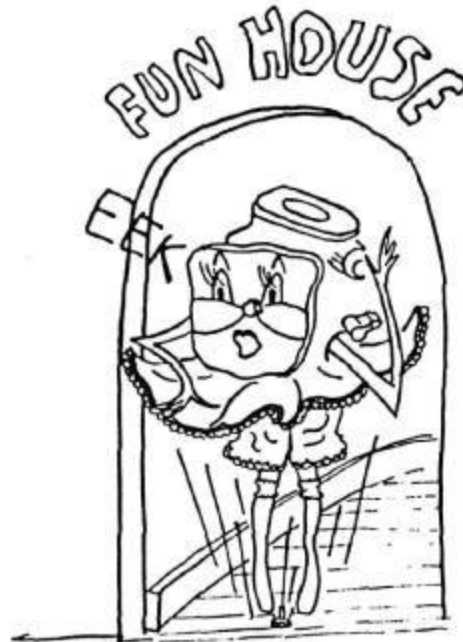

fuel circuit in addition to the fuel supplied by the main metering jet. On the carburetors equipped with the airflow enrichment valve the idle needle valve will be of a slightly different design, (without cruise step) as shown in figure 3. Also the idle needle diaphragm spring will be removed as well as the enrichment valve actuating screw

from the loose lever assembly. Refer to figure 5, for a detailed schematic view of the airflow power enrichment valve.

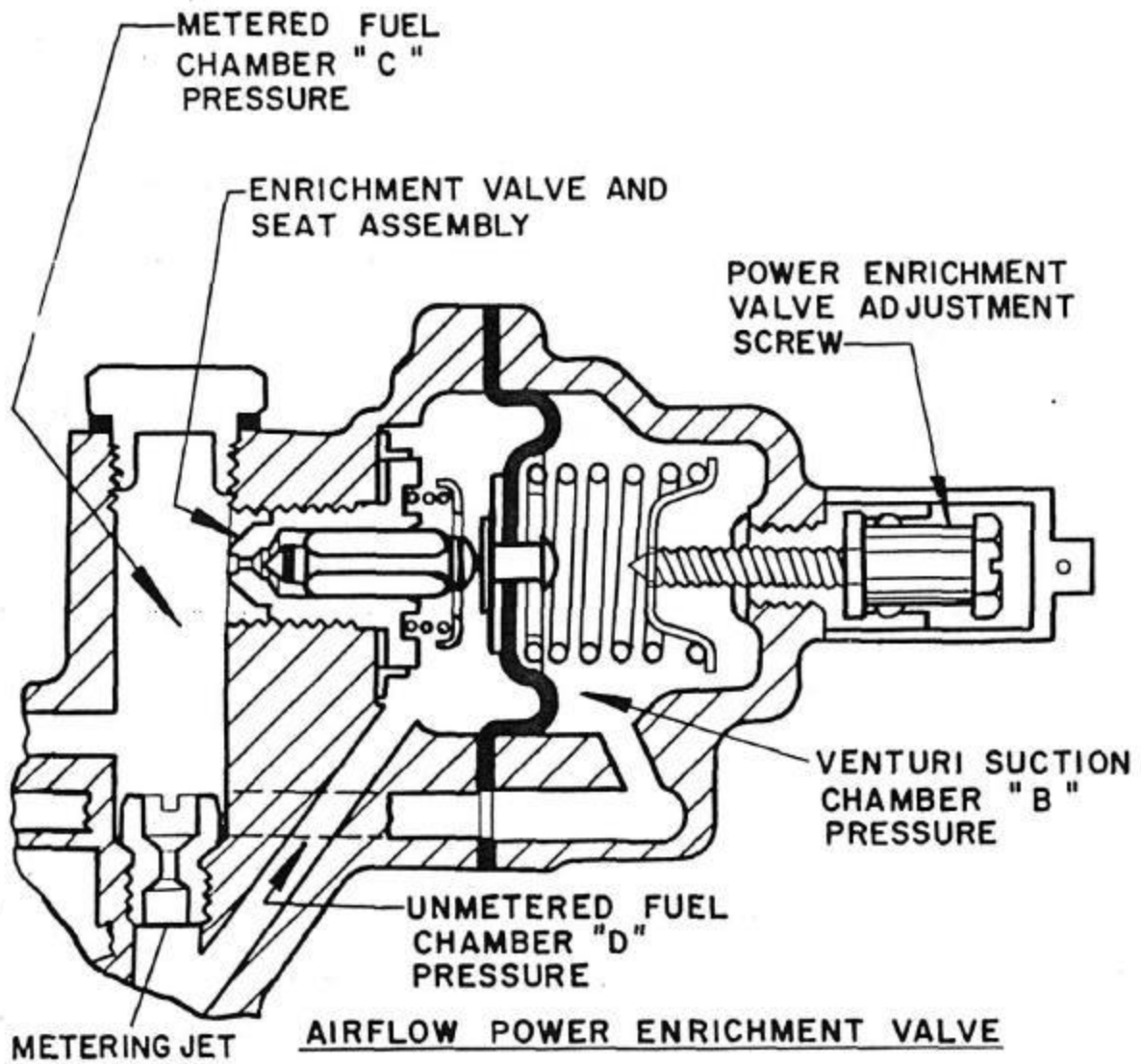

Figure 5.

AUTOMATIC MIXTURE CONTROL ASSEMBLY

2-9. The automatic mixture control assembly is a device that works independently of, and in parallel with the manual mixture control to automatically correct for natural enrichment at altitude. In effect, it provides a variable bleed between chambers "A" and "B" of the carburetor to regulate metering suction.



2-10. By reference to figure 6, you will see that the automatic mixture control consists of a contoured needle that is moved in or out of an orifice by a bellows assembly. This bellows assembly is similar to a barometer in that it is sensitive to both air pressure and temperature. Generally speaking, at ground level the bellows is contracted and holds the needle in the orifice in such a position that the flow of "impact pressure" into "venturi suction" is at a minimum and "metering suction" is therefore at a maximum. As altitude increases the bellows elongates and repositions the needle in the orifice allowing more "impact pressure" to flow into the "venturi suction" chamber maintaining the ground level metering suction.

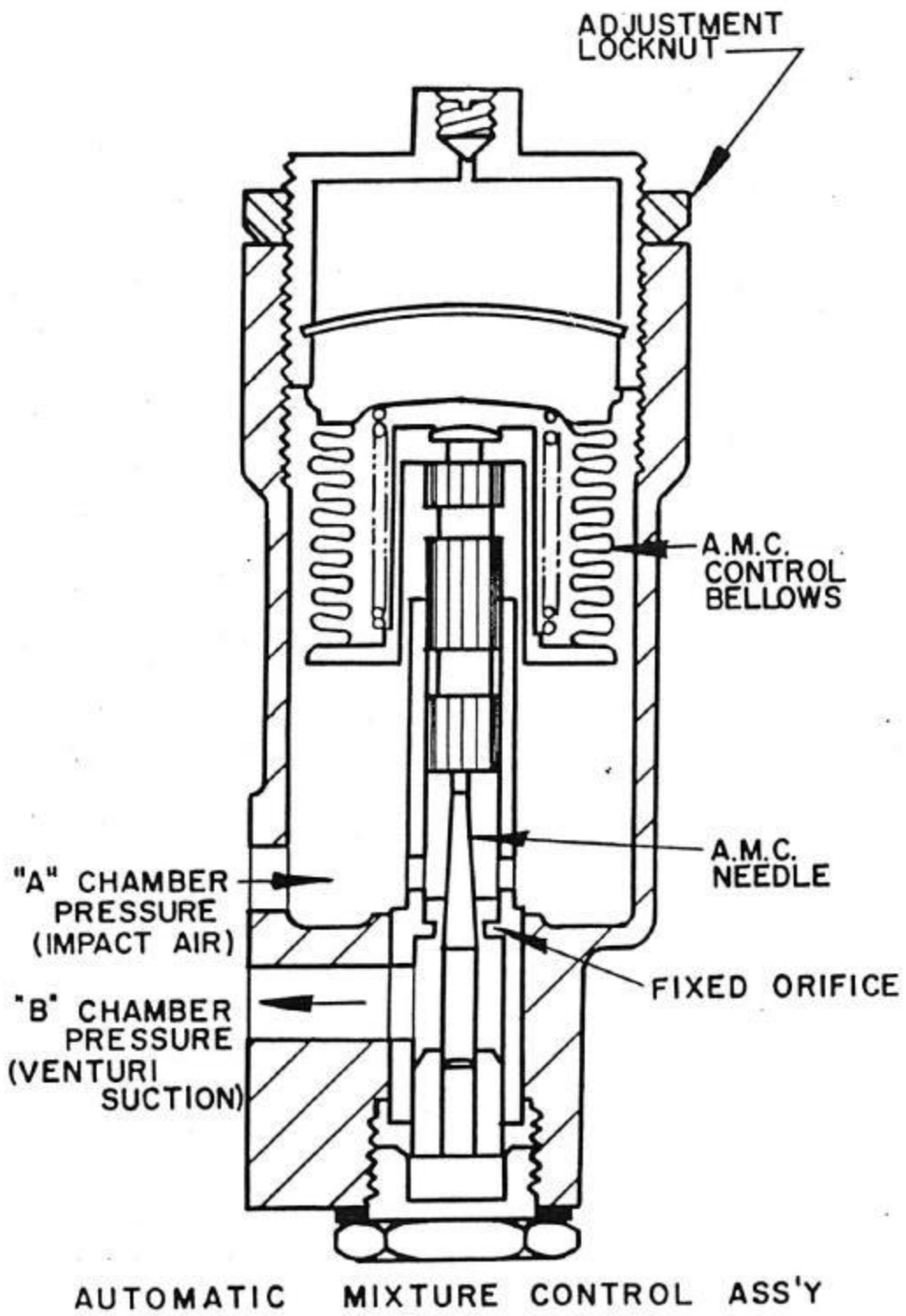
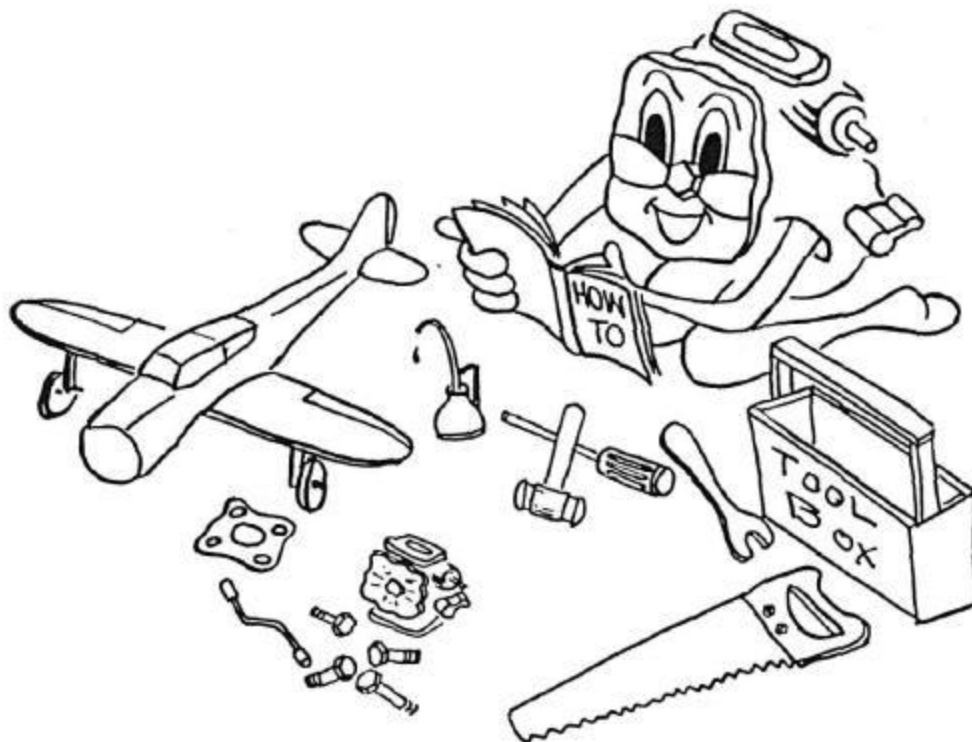

Figure 6.

SECTION III



INSTALLATION

ENGINE

3-1. Install the carburetor on the mounting pad of the engine using the proper gasket and torque the four attaching nuts to the specified torque. Refer to the engine manufacturer's instructions and bill of material for applicable torque specifications and correct attaching parts, i.e., gaskets, fittings, etc.

a. All "PS" type carburetors should be installed so the fuel will discharge directly into the intake manifold or blower throat, whichever the case may be.

b. Carburetors installed for horizontal operation should be installed with the discharge diaphragm adjusting screw pointing down.

c. When installing the carburetor extreme care should be taken against sliding the flange of the carburetor over the attaching studs of the manifold as the face of the carburetor flange can become scratched and allow an air leak at this point.

AIR SCOOP



3-2. Attach the air scoop adapter to the mounting flange of the carburetor with the proper gasket installed and torque the cap screws evenly.



a. On all PS-5 carburetors equipped with an Automatic Mixture Control mounted on the main body an auxiliary air blast tube should be provided. Follow the aircraft manufacturer's instructions for installing this tube.

b. On some PS-5 and all PS-7 and PS-9 carburetors equipped with an Automatic Mixture Control the Automatic Mixture Control Assembly is mounted on a special adapter that is part of the carburetor.

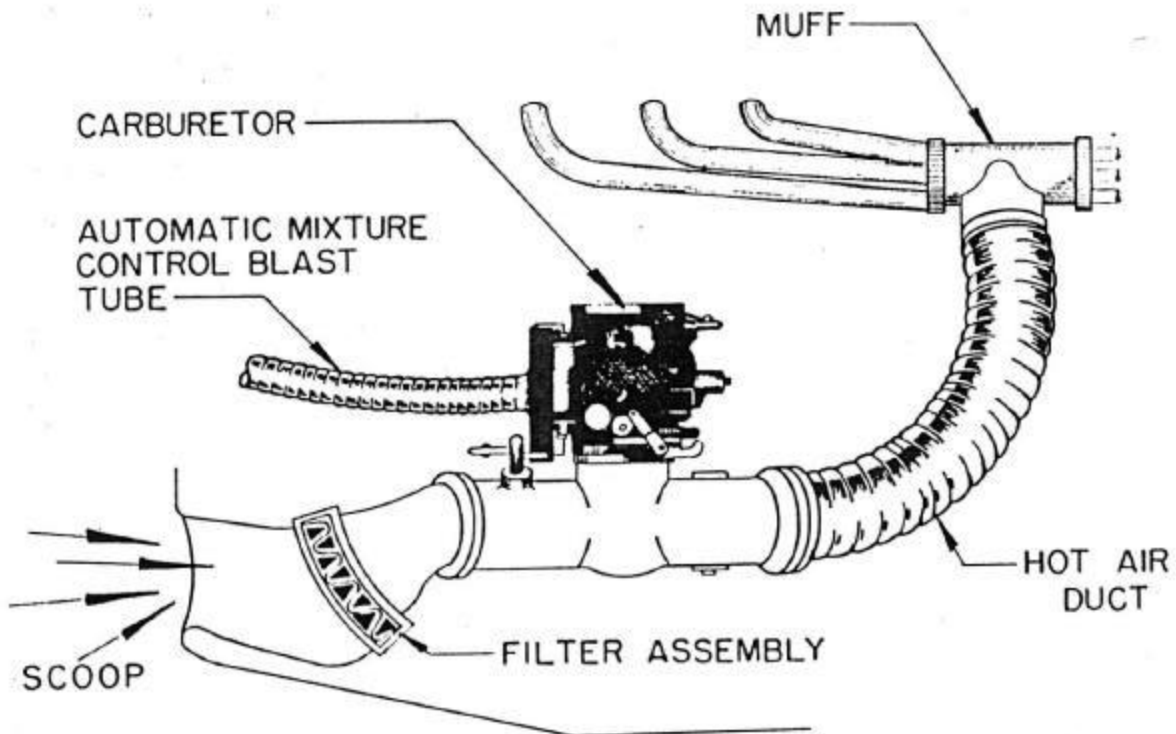

TYPICAL SCOOP INSTALLATION USING A PS-5BD CARBURETOR

Figure 7.

The air scoop attaches to this adapter, so that when assembled, the Automatic Mixture Control is located within the air scoop. Refer to figures 7 and 8 for examples of typical scoop installations.

c. Either of the above two arrangements is necessary as the Automatic Mixture Control must sense carburetor inlet air temperature only and not engine compartment air temperature.

d. Follow the aircraft manufacturer's instructions for cleaning and oiling the air filter element. Be sure the recommended grade of oil is used for re-oiling the element and that an ample amount of time is allowed for draining. A filter element replaced with an excess amount of oil clinging to it can cause fuel metering difficulties as the excess oil will be drawn into the scoop and will settle on the venturi tube of the carburetor. This can greatly affect the metering characteristics of the carburetor.

3-3. When necessary to remove the scoop adapter from the carburetor, it should be broken loose by light tapping with a soft faced mallet, do not remove by prying, as the scoop flange of the carburetor can become scratched or otherwise distorted.

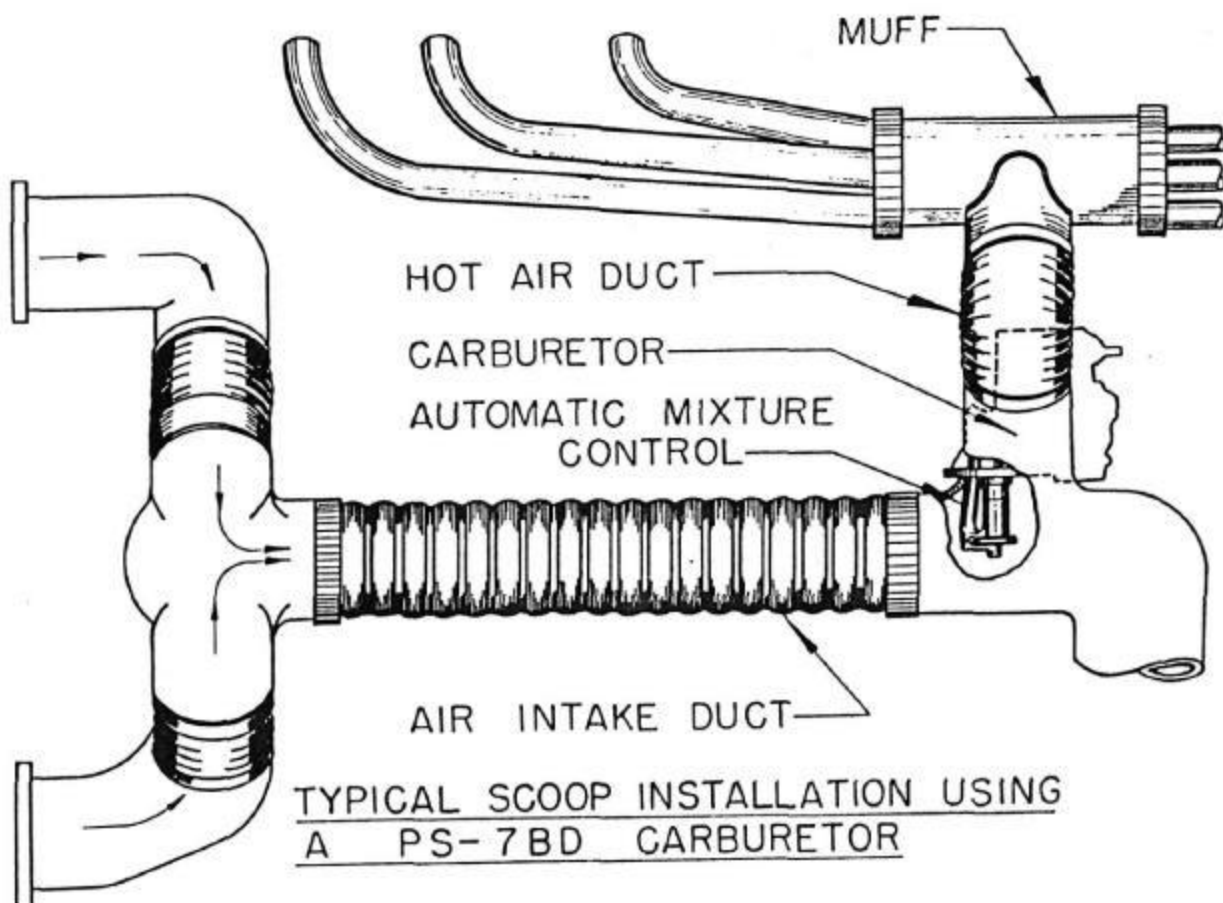
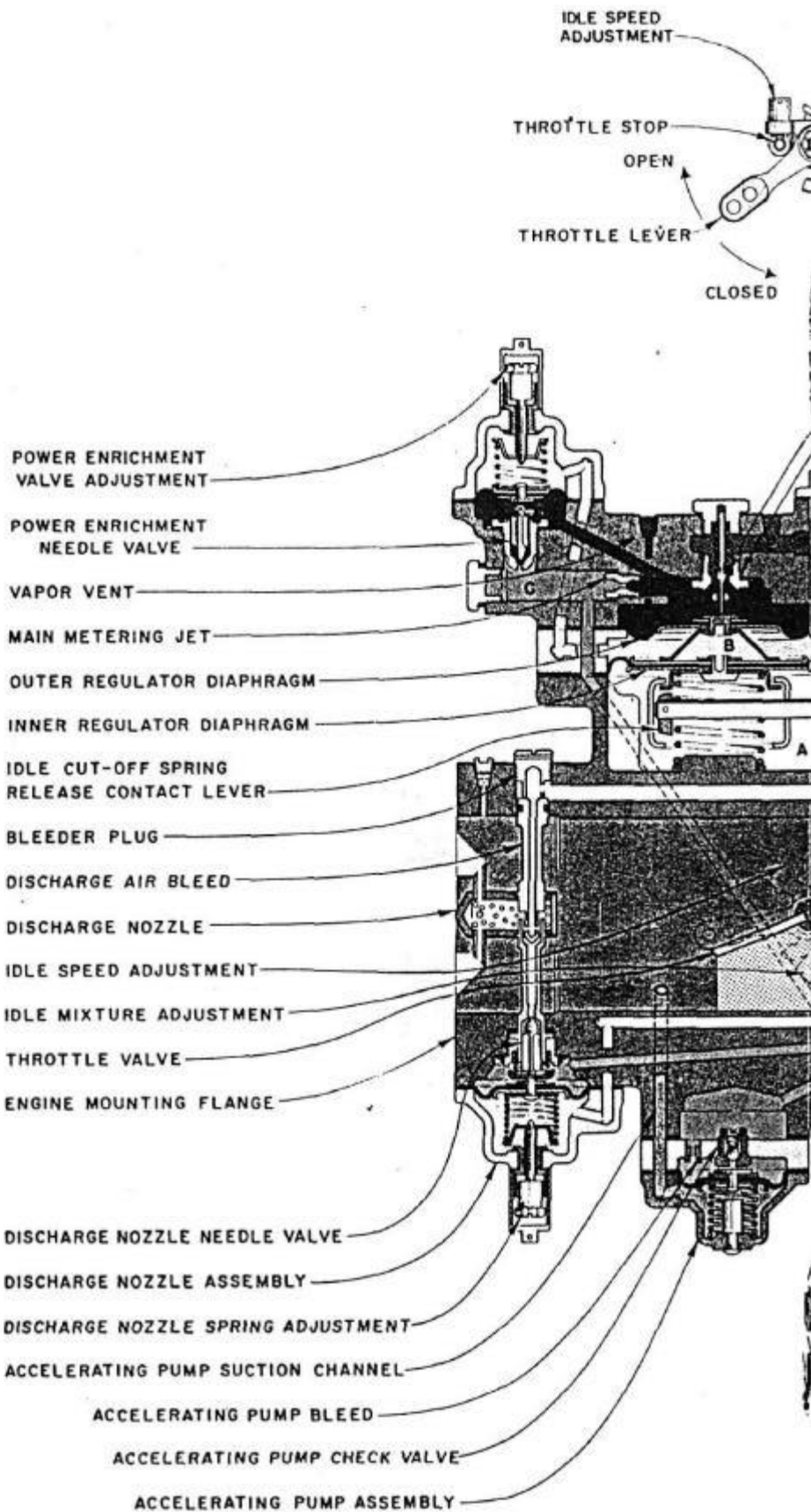

Figure 8.



Schematic Diagram of the Stromberg

Copyright ©
 THE BENDIX CO
 South Bend, In