



652 Oliver Street
Williamsport, PA 17701 U.S.A.

Telephone +1 (800) 258-3279 (U.S. and Canada)
Telephone +1 (570) 323-6181 (International)
Facsimile +1 (570) 327-7101

www.lycoming.com

MANDATORY

SERVICE BULLETIN

DATE: October 18, 2016

Service Bulletin No. 533C
(Supersedes Service Bulletin No. 533B)
Engineering Aspects are
FAA Approved

SUBJECT: Recommended Action for Sudden Engine Stoppage, Propeller/Rotor Strike or Loss of Propeller/Rotor Blade or Tip

MODELS AFFECTED: All Lycoming reciprocating aircraft engines

TIME OF COMPLIANCE: BEFORE FURTHER FLIGHT

REASON FOR REVISION Applies to all Lycoming aircraft engines (not just direct drive engines); added checklist specific for Lycoming geared engines; updated checklist which applies to all other Lycoming aircraft engines, added check for connecting rod squareness to the checklists.

NOTICE: Incomplete review of all the information in this document can cause errors. Read the entire Service Bulletin to make sure you have a complete understanding of the requirements.

This Service Bulletin identifies propeller/rotor damage conditions and gives corrective action recommendations for aircraft engines that have had propeller /rotor damage as well as any of the following:

- Separation of the propeller/rotor blade from the hub
- Loss of a propeller or rotor blade tip
- Sudden stoppage

A propeller strike includes:

- Any incident, whether or not the engine is operating, where repair of the propeller is necessary
- Any incident during engine operation where the propeller has impact on a solid object. This incident includes propeller strikes against the ground. Although the propeller can continue to turn, damage to the engine can occur, possibly with progression to engine failure
- Sudden RPM drop on impact to water, tall grass, or similar yielding medium where propeller damage does not usually occur

A propeller strike can occur at taxi speeds and during touch-and-go operations with propeller tip ground contact. In addition, propeller strikes also include situations where an aircraft is stationary and a landing gear collapse occurs causing one or more blades to be bent, or where a hangar door (or other object) hits the propeller blade. These instances are cases of sudden engine stoppage because of potentially severe side loading on the crankshaft propeller flange, front bearing, and seal.



General Aviation
Manufacturers Association

ISSUED			REVISED			PAGE NO.	REVISION
MO	DAY	YEAR	MO	DAY	YEAR	1 of 16	C
06	29	98	10	18	16		

⚠ CAUTION: BASED UPON THE ACCUMULATED ENGINEERING, TECHNICAL, AND HISTORICAL DATA AVAILABLE, LYCOMING ENGINES **PROHIBITS** STRAIGHTENING OR GRINDING OF BENT CRANKSHAFT PROPELLER FLANGES TO RESTORE MAXIMUM RUN-OUT SPECIFICATION AS NOTED IN THE LATEST REVISION OF THE SERVICE TABLE OF LIMITS - SSP-1776. IF THE CRANKSHAFT PROPELLER FLANGE IS BENT, REPLACE THE CRANKSHAFT. **DO NOT TRY TO STRAIGHTEN OR GRIND THE CRANKSHAFT PROPELLER FLANGE.**

Recommended Corrective Action for Propeller Strikes

⚠ CAUTION: DAMAGE TO A PROPELLER IS SERIOUS AND CAN CAUSE THE ENGINE TO BE UNAIRWORTHY.

Circumstances of a propeller strike cannot always be used as predictors for the extent of engine damage or its future reliability. There can be varying degrees of damage to an engine and propeller from a propeller strike. The initial damage can be hidden but could become progressively worse with time and wear.

Given these possibilities and the fact that there is no identified clear, quantifiable threshold limit or gradient standard to reliably measure the extent of damage to an engine, Lycoming Engines can only recommend **BEFORE FURTHER FLIGHT**, that you complete the tasks in the sequential order shown in the applicable “Inspection Checklist After a Propeller Strike” included in this Service Bulletin as the corrective action for a propeller strike. One checklist applies specifically to Lycoming geared engines (GO-435, GO-480, GSO-480, IGO-480, IGO-540, IGSO-540, and TIGO-541) while the other checklist is for all other Lycoming aircraft engines. Make a copy of the checklist that applies to your engine model, complete it and keep it as a service record. Record all results and any corrective action taken in compliance as per the revision of this Service Bulletin in the engine logbook.

NOTICE: The agency that returns the aircraft to service is responsible for the decision to operate an engine that had a propeller strike. Lycoming Engines does not take the responsibility for the decision to return the engine to service after a propeller strike.

ISSUED			REVISED			PAGE NO.	REVISION	S.B. 533
MO	DAY	YEAR	MO	DAY	YEAR	2 of 16	C	
06	29	98	10	18	16			

Engine Inspection Checklist After Propeller Strike for All Lycoming Engines - Except Geared Engines

Engine Model:		Engine Serial Number:	
Date Inspection Started:		Date Inspection Completed:	
Sequential Task		Additional Information	Corrective Action Done/Comments
1.	Examine the propeller for extent of damage; record condition of propeller.	Condition of Propeller/Corrective Action: <input type="checkbox"/> Propeller satisfactory <input type="checkbox"/> Repair propeller in accordance with propeller manufacturer's instructions <input type="checkbox"/> Replace propeller in accordance with the airframe manufacturer's instructions.	
2.	Remove the propeller.	As per the airframe and propeller manufacturer's instructions.	
3.	Remove the engine.	In accordance with the airframe manufacturer's instructions.	
CRANKCASE P/N:		MATCH NO:	
4.	Disassemble the engine - remove the crankshaft, camshaft, connecting rods, crankshaft gear, and internal steel parts.	In accordance with the applicable Lycoming engine manual.	
5.	Complete blast cleaning of the crankcase with 17 grit walnut shells or equivalent at 35 to 45 psi (241 to 310 kPa); remove all coatings on the crankcase and engine mount bosses.	Make sure there is no dirt, debris, sludge, paint, or any other substance that could prevent reliable Fluorescent Penetrant Inspection (FPI) or subsequent oil flow.	
6.	Complete blast cleaning of the oil sump and engine mount bosses with 17 grit walnut shells or equivalent at 35 to 45 psi (241 to 310 kPa).	Make sure there is no dirt, debris, sludge, paint, or any other substance that could prevent reliable FPI or subsequent oil flow.	
7.	Complete blast cleaning of the engine mount brackets (on six-cylinder engines) and, if used, the lower mount rings (on helicopter engines) with 17 grit walnut shells or equivalent at 35 to 45 psi (241 to 310 kPa).	Make sure there is no dirt, debris, sludge, paint, or any other substance that could prevent reliable FPI or subsequent oil flow.	
8.	Complete blast cleaning of the accessory housing with 17 grit walnut shells or equivalent at 35 to 45 psi (241 to 310 kPa).	Make sure there is no dirt, debris, sludge, paint, or any other substance that could prevent reliable FPI or subsequent oil flow.	

ISSUED			REVISED			PAGE NO.	REVISION	S.B. 533
MO	DAY	YEAR	MO	DAY	YEAR	3 of 16	C	
06	29	98	10	18	16			

**Engine Inspection Checklist After Propeller Strike for All Lycoming Engines - Except Geared Engines
(Cont.)**

Sequential Task		Additional Information	Corrective Action Done/Comments
9.	Remove and discard the existing crankshaft gear retaining bolt and lockplate.		
10.	Examine the crankshaft.	Refer to the applicable Lycoming engine manual and the latest revision of the Service Table of Limits - SSP-1776 for the crankshaft disassembly and inspection procedures.	
11.	Examine, the crankshaft counter-bored recess, the alignment dowel especially at the base where it goes into the crankshaft, the bolt hole threads, and the crankshaft gear for wear, galling, corrosion, and fretting.	Refer to the latest revision of Service Bulletin No. SB-475. If the bolt hole threads are damaged, they cannot be repaired. Replace the crankshaft.	
12.	Clean the crankshaft, camshaft, crankshaft gear, counterweights, rollers and bushings.	Make sure there is no dirt, debris, sludge, paint, or any other substance that could prevent reliable magnetic particle inspection or subsequent oil flow.	
13.	Clean the following internal parts made of steel: <ul style="list-style-type: none"> • Connecting rods • Tappets (not roller tappets) • Piston pins • Rocker shafts • Accessory drive gears • Magneto drive gears • Idler and oil pump shafts • Shaft gears and impellers 		

⚠ CAUTION: BASED UPON THE ACCUMULATED ENGINEERING, TECHNICAL, AND HISTORICAL DATA AVAILABLE, LYCOMING ENGINES PROHIBITS STRAIGHTENING OR GRINDING OF BENT CRANKSHAFT PROPELLER FLANGES TO RESTORE MAXIMUM RUN-OUT SPECIFICATION AS NOTED IN THE LATEST REVISION OF THE SERVICE TABLE OF LIMITS - SSP-1776. IF THE CRANKSHAFT PROPELLER FLANGE IS BENT, REPLACE THE CRANKSHAFT. DO NOT TRY TO STRAIGHTEN OR GRIND THE CRANKSHAFT PROPELLER FLANGE.

ISSUED			REVISED			PAGE NO.	REVISION	S.B. 533
MO	DAY	YEAR	MO	DAY	YEAR			
06	29	98	10	18	16	4 of 16	C	

**Engine Inspection Checklist After Propeller Strike for All Lycoming Engines - Except Geared Engines
(Cont.)**

CRANKSHAFT P/N:

S/N:

Sequential Task		Additional Information	Corrective Action Done/Comments
14.	Measure the flange run-out on the crankshaft.	Refer to the latest revisions of both Service Bulletin No. SB-240 and the Service Table of Limits - SSP-1776 for crankshaft flange run-out tolerance. Record the crankshaft flange run-out measurement.*	<input type="checkbox"/> Use crankshaft <input type="checkbox"/> Replace crankshaft
15.	Measure the main bearing run-out on the crankshaft.	Refer to the latest revision of the Service Table of Limits - SSP-1776 for the main bearing run-out tolerance Record the main bearing run-out measurement.*	<input type="checkbox"/> Use crankshaft <input type="checkbox"/> Replace crankshaft
16.	Measure the polished dimensions on the main journals.	Refer to the latest revision of the Service Table of Limits - SSP-1776 for the dimensions on the main journals Record the dimensions of the main journals.*	<input type="checkbox"/> Main journals within acceptable limits - use crankshaft <input type="checkbox"/> Replace crankshaft
17.	Measure the polished dimensions on the pin journals.	Refer to the latest revision of the Service Table of Limits - SSP-1776 for the dimensions on the pin journals Record the dimensions of the pin journals.*	<input type="checkbox"/> Pin journals within acceptable limits - use crankshaft <input type="checkbox"/> Replace crankshaft

* If the measurement or dimension is out of tolerance, discard the crankshaft and replace it with a serviceable crankshaft. Install the crankshaft per the applicable Lycoming manual and the latest revision of the Service Table of Limits - SSP-1776.

18.	Complete a check of connecting rod parallelism.	Refer to the section "Connecting Rod Parallelism/Squareness Check" in this Service Bulletin. Record the parallelism measurement for each connecting rod. Replace all connecting rods not in compliance with measurements in the latest revision of the Service Table of Limits - SSP-1776 (Reference 503).	Parallelism Measurement	
			Connecting Rod 1	
			Connecting Rod 2	
			Connecting Rod 3	
			Connecting Rod 4	
			Connecting Rod 5	
			Connecting Rod 6	
			Connecting Rod 7	
			Connecting Rod 8	

ISSUED			REVISED			PAGE NO.	REVISION	S.B. 533
MO	DAY	YEAR	MO	DAY	YEAR			
06	29	98	10	18	16	5 of 16	C	

Engine Inspection Checklist After Propeller Strike for All Lycoming Engines - Except Geared Engines (Cont.)

	Sequential Task	Additional Information	Corrective Action Done/Comments	
19.	Complete a check of connecting rod squareness.	Refer to the section "Connecting Rod Parallelism/Squareness Check" in this Service Bulletin. Record the squareness measurement for each connecting rod. Replace all connecting rods not in compliance with measurements in the latest revision of the Service Table of Limits - SSP-1776 (Reference 504).	Squareness Measurement	
			Connecting Rod 1	
			Connecting Rod 2	
			Connecting Rod 3	
			Connecting Rod 4	
			Connecting Rod 5	
			Connecting Rod 6	
			Connecting Rod 7	
			Connecting Rod 8	

NOTICE: The magnetic particle inspection must be done by a certified technician as per the latest revision of Service Instruction No. SI-1285.

20.	Complete a magnetic particle inspection on the crankshaft.	Record test results.	<input type="checkbox"/> Use crankshaft <input type="checkbox"/> Replace crankshaft	
21.	Complete a magnetic particle inspection on the crankshaft counterweights. Examine the counterweight bushing bores in both the counterweights and the crankshaft.	Record test results.	Replace all counterweight pins, bushings, end plates and snap rings - regardless of their condition.	
22.	Complete a magnetic particle inspection on the camshaft.	Record test results.	<input type="checkbox"/> Use camshaft <input type="checkbox"/> Replace camshaft	
23.	Complete a magnetic particle inspection on the connecting rods.	Record test results.	Replace connecting rod bolts and nuts -regardless of condition. Refer to the latest revision of Service Instruction No. SI-1458 for assembly instructions.	
24.	Complete a magnetic particle inspection on the crankshaft gear; examine the gear end as per the latest revision of Service Bulletin No. SB-475.	Record test results.	<input type="checkbox"/> Use crankshaft gear <input type="checkbox"/> Replace crankshaft gear	
25.	Complete a magnetic particle inspection on the following internal parts made of steel: <ul style="list-style-type: none"> • Accessory drive gears • Magneto drive gears • Idler and oil pump shafts • Shaft gears and impellers • Piston pins • Connecting rods 	Record test results.	Use Replace <input type="checkbox"/> <input type="checkbox"/> Accessory drive gears <input type="checkbox"/> <input type="checkbox"/> Magneto drive gears <input type="checkbox"/> <input type="checkbox"/> Idler and oil pump shafts <input type="checkbox"/> <input type="checkbox"/> Shaft gears and impellers <input type="checkbox"/> <input type="checkbox"/> Piston pins <input type="checkbox"/> <input type="checkbox"/> Connecting rods	

ISSUED			REVISED			PAGE NO.	REVISION	S.B. 533
MO	DAY	YEAR	MO	DAY	YEAR			
06	29	98	10	18	16	6 of 16	C	

**Engine Inspection Checklist After Propeller Strike for All Lycoming Engines - Except Geared Engines
(Cont.)**

Sequential Task		Additional Information	Corrective Action Done/Comments
26.	Complete the visual inspection and Fluorescent Penetrant Inspection (FPI) on the crankcase. Refer to the latest revision of Service Instruction No. SI-1285. Closely examine the forward crankcase bearing support and adjacent structure.	Record test results.	<input type="checkbox"/> Use crankcase <input type="checkbox"/> Replace crankcase
27.	Complete the visual inspection and FPI on the oil sump.	Record test results.	<input type="checkbox"/> Use oil sump <input type="checkbox"/> Replace oil sump
28.	Complete the visual inspection and FPI on the engine mounts and, if used, the lower mount rings (on helicopter engines).	Record test results.	<input type="checkbox"/> Use engine mounts <input type="checkbox"/> Replace engine mounts
29.	Complete the visual inspection and FPI on the accessory housing.	Record test results.	<input type="checkbox"/> Use accessory housing <input type="checkbox"/> Replace accessory housing
30.	Complete the visual inspection on the oil pump impeller.	Record test results.	<input type="checkbox"/> Use impeller <input type="checkbox"/> Replace impeller
NOTICE: Roller tappets, counterweight rollers, and bushings must be replaced.			
31.	Complete the visual inspection and FPI on the tappets (not roller tappets) and lifters. Refer to the latest revision of Service Instruction No. SI-1011.	Record test results.	<input type="checkbox"/> Tappets/lifters acceptable <input type="checkbox"/> Replace tappets/lifters
32.	Examine each magneto in accordance with the magneto manufacturer's instructions.	Record test results.	<input type="checkbox"/> Replace magneto
33.	Examine the pistons as per instructions in the applicable Lycoming manual and the latest revision of the Service Table of Limits - SSP-1776.	Record test results.	<input type="checkbox"/> Pistons acceptable <input type="checkbox"/> Replace pistons
34.	Refer to the latest revision of Service Bulletin No. SB-240 to identify any parts that must be replaced during engine assembly.	Record parts that must be replaced.	
35.	Install a new crankshaft gear retaining bolt and lockplate.	Refer to the latest revision of Service Bulletin No. SB-475.	

ISSUED			REVISED			PAGE NO.	REVISION	S.B. 533
MO	DAY	YEAR	MO	DAY	YEAR	7 of 16	C	
06	29	98	10	18	16			

**Engine Inspection Checklist After Propeller Strike for All Lycoming Engines - Except Geared Engines
(Cont.)**

Sequential Task		Additional Information	Corrective Action Done/Comments
36.	Review the documents of all other engine-mounted accessories on the engine, propeller governor (if installed), etc. for instructions on what to do for components exposed to sudden engine stoppage.		
37.	Assemble and install the engine. Install the propeller and test the engine. Complete an operational check of the engine.	In accordance with instructions in the applicable Lycoming engine manuals, the latest revisions of the Service Table of Limits - SSP-1776 and Service Instruction No. SI-1427.	
38.	Record maintenance findings and any corrective action in the engine logbook.		

UNAIRWORTHY PARTS:

ADDITIONAL WORK/INSPECTIONS NECESSARY:

OUTCOME OF INSPECTION- SUMMARY NOTES:

ISSUED			REVISED			PAGE NO.	REVISION	S.B. 533
MO	DAY	YEAR	MO	DAY	YEAR			
06	29	98	10	18	16	8 of 16	C	

Engine Inspection Checklist After Propeller Strike for All Lycoming Geared Engines

Engine Model:		Engine Serial Number:	
Date Inspection Started:		Date Inspection Completed:	
Sequential Task		Additional Information	Corrective Action Done/Comments
1.	Examine the propeller for extent of damage; record condition of propeller.	Condition of Propeller/Corrective Action: <input type="checkbox"/> Propeller satisfactory <input type="checkbox"/> Repair propeller in accordance with propeller manufacturer's instructions <input type="checkbox"/> Replace propeller in accordance with the airframe manufacturer's instructions.	
2.	Remove the propeller.	As per the airframe and propeller manufacturer's instructions.	
3.	Remove the engine.	In accordance with the airframe manufacturer's instructions.	
CRANKCASE P/N:		MATCH NO:	
4.	Disassemble the engine - remove the crankshaft, camshaft, connecting rods, crankshaft gear, and internal steel parts.	In accordance with the applicable Lycoming engine manual.	
5.	Complete blast cleaning of the crankcase with 17 grit walnut shells or equivalent at 35 to 45 psi (241 to 310 kPa); remove all coatings on the crankcase and engine mount bosses.	Make sure there is no dirt, debris, sludge, paint, or any other substance that could prevent reliable Fluorescent Penetrant Inspection (FPI) or subsequent oil flow.	
6.	Complete blast cleaning of the oil sump and engine mount bosses with 17 grit walnut shells or equivalent at 35 to 45 psi (241 to 310 kPa).	Make sure there is no dirt, debris, sludge, paint, or any other substance that could prevent reliable FPI or subsequent oil flow.	
7.	Complete blast cleaning of the engine mount brackets (on six-cylinder engines) and, if used, the lower mount rings (on helicopter engines) with 17 grit walnut shells or equivalent at 35 to 45 psi (241 to 310 kPa).	Make sure there is no dirt, debris, sludge, paint, or any other substance that could prevent reliable FPI or subsequent oil flow.	
8.	Complete blast cleaning of the accessory housing with 17 grit walnut shells or equivalent at 35 to 45 psi (241 to 310 kPa).	Make sure there is no dirt, debris, sludge, paint, or any other substance that could prevent reliable FPI or subsequent oil flow.	

ISSUED			REVISED			PAGE NO.	REVISION	S.B. 533
MO	DAY	YEAR	MO	DAY	YEAR			
06	29	98	10	18	16	9 of 16	C	

Engine Inspection Checklist After Propeller Strike for All Lycoming Geared Engines (Cont.)

	Sequential Task	Additional Information	Corrective Action Done/Comments
9.	Remove and discard the existing crankshaft gear retaining bolt and lockplate.		
10.	Examine the crankshaft.	Refer to the applicable Lycoming engine manual and the latest revision of the Service Table of Limits - SSP-1776 for the crankshaft disassembly and inspection procedures.	
11.	Examine, the crankshaft counter-bored recess, the alignment dowel especially at the base where it goes into the crankshaft, the bolt hole threads, and the crankshaft gear for wear, galling, corrosion, and fretting.	Refer to the latest revision of Service Bulletin No. SB-475. If the bolt hole threads are damaged, they cannot be repaired. Replace the crankshaft.	
12.	Clean the crankshaft, camshaft, crankshaft gear, counterweights, rollers and bushings.	Make sure there is no dirt, debris, sludge, paint, or any other substance that could prevent reliable magnetic particle inspection or subsequent oil flow.	
13.	Clean the following internal parts made of steel: <ul style="list-style-type: none"> • Connecting rods • Tappets and lifters • Piston pins • Rocker shafts • Accessory drive gears • Magneto drive gears • Idler and oil pump shafts • Shaft gears and impellers 		

⚠ CAUTION: BASED UPON THE ACCUMULATED ENGINEERING, TECHNICAL, AND HISTORICAL DATA AVAILABLE, LYCOMING ENGINES PROHIBITS STRAIGHTENING OR GRINDING OF BENT CRANKSHAFT PROPELLER FLANGES TO RESTORE MAXIMUM RUN-OUT SPECIFICATION AS NOTED IN THE LATEST REVISION OF THE SERVICE TABLE OF LIMITS - SSP-1776. IF THE CRANKSHAFT PROPELLER FLANGE IS BENT, REPLACE THE CRANKSHAFT. DO NOT TRY TO STRAIGHTEN OR GRIND THE CRANKSHAFT PROPELLER FLANGE.

ISSUED			REVISED			PAGE NO.	REVISION	S.B. 533
MO	DAY	YEAR	MO	DAY	YEAR	10 of 16	C	
06	29	98	10	18	16			

Engine Inspection Checklist After Propeller Strike for All Lycoming Geared Engines (Cont.)

CRANKSHAFT P/N:

S/N:

Sequential Task		Additional Information	Corrective Action Done/Comments
14.	Measure the flange run-out on the crankshaft.	Refer to the latest revisions of both Service Bulletin No. SB-240 and the Service Table of Limits - SSP-1776 for crankshaft flange run-out tolerance. Record the crankshaft flange run-out measurement.*	<input type="checkbox"/> Use crankshaft <input type="checkbox"/> Replace crankshaft
15.	Measure the main bearing run-out on the crankshaft.	Refer to the latest revision of the Service Table of Limits - SSP-1776 for the main bearing run-out tolerance Record the main bearing run-out measurement.*	<input type="checkbox"/> Use crankshaft <input type="checkbox"/> Replace crankshaft
16.	Measure the polished dimensions on the main journals.	Refer to the latest revision of the Service Table of Limits - SSP-1776 for the dimensions on the main journals Record the dimensions of the main journals.*	<input type="checkbox"/> Main journals within acceptable limits - use crankshaft <input type="checkbox"/> Replace crankshaft
17.	Measure the polished dimensions on the pin journals.	Refer to the latest revision of the Service Table of Limits - SSP-1776 for the dimensions on the pin journals. Record the dimensions of the pin journals.*	<input type="checkbox"/> Pin journals within acceptable limits - use crankshaft <input type="checkbox"/> Replace crankshaft

* If the measurement or dimension is out of tolerance, discard the crankshaft and replace it with a serviceable crankshaft. Install the crankshaft per the applicable Lycoming manual and the latest revision of the Service Table of Limits - SSP-1776.

18.	Complete a check of connecting rod parallelism.	Refer to the section "Connecting Rod Parallelism/Squareness Check" in this Service Bulletin. Record the parallelism measurement for each connecting rod. Replace all connecting rods not in compliance with measurements in the latest revision of the Service Table of Limits - SSP-1776 (Reference 503).	Parallelism Measurement	
			Connecting Rod 1	
			Connecting Rod 2	
			Connecting Rod 3	
			Connecting Rod 4	
			Connecting Rod 5	
			Connecting Rod 6	
			Connecting Rod 7	
			Connecting Rod 8	

ISSUED			REVISED			PAGE NO.	REVISION	S.B. 533
MO	DAY	YEAR	MO	DAY	YEAR			
06	29	98	10	18	16	11 of 16	C	

Engine Inspection Checklist After Propeller Strike for All Lycoming Geared Engines (Cont.)

	Sequential Task	Additional Information	Corrective Action Done/Comments
19.	Complete a check of connecting rod squareness.	Refer to the section "Connecting Rod Parallelism/Squareness Check" in this Service Bulletin. Record the squareness measurement for each connecting rod. Replace all connecting rods not in compliance with measurements in the latest revision of the Service Table of Limits - SSP-1776 (Reference 504).	Squareness Measurement
			Connecting Rod 1
			Connecting Rod 2
			Connecting Rod 3
			Connecting Rod 4
			Connecting Rod 5
			Connecting Rod 6
			Connecting Rod 7
			Connecting Rod 8

NOTICE: The magnetic particle inspection must be done by a certified technician as per the latest revision of Service Instruction No. SI-1285.

20.	Complete a magnetic particle inspection on the crankshaft.	Record test results.	<input type="checkbox"/> Use crankshaft <input type="checkbox"/> Replace crankshaft
21.	Complete a magnetic particle inspection on the crankshaft counterweights. Examine the counterweight bushing bores in both the counterweights and the crankshaft.	Record test results.	Replace all counterweight pins, bushings, end plates and snap rings - regardless of their condition.
22.	Complete a magnetic particle inspection on the camshaft.	Record test results.	<input type="checkbox"/> Use camshaft <input type="checkbox"/> Replace camshaft
23.	Complete a magnetic particle inspection on the connecting rods.	Record test results.	Replace connecting rod bolts and nuts -regardless of condition. Refer to the latest revision of Service Instruction No. SI-1458 for assembly instructions.
24.	Complete a magnetic particle inspection on the crankshaft gear; examine the gear end as per the latest revision of Service Bulletin No. SB-475.	Record test results.	<input type="checkbox"/> Use crankshaft gear <input type="checkbox"/> Replace crankshaft gear
25.	Complete a magnetic particle inspection on the following internal parts made of steel: <ul style="list-style-type: none"> • Accessory drive gears • Magneto drive gears • Idler and oil pump shafts • Shaft gears and impellers • Piston pins • Connecting rods • Propeller shaft • Stationary gear • Thrust bearing oil slinger • Pinion roller • Pinion gear • Pinion gear drive plate • Pinion cage • Stationary gear drive plate • Supercharger shaft gear (if equipped) 	Record test results.	Use Replace <input type="checkbox"/> <input type="checkbox"/> Accessory drive gears <input type="checkbox"/> <input type="checkbox"/> Magneto drive gears <input type="checkbox"/> <input type="checkbox"/> Idler and oil pump shafts <input type="checkbox"/> <input type="checkbox"/> Shaft gears and impellers <input type="checkbox"/> <input type="checkbox"/> Piston pins <input type="checkbox"/> <input type="checkbox"/> Connecting rods <input type="checkbox"/> <input type="checkbox"/> Propeller shaft <input type="checkbox"/> <input type="checkbox"/> Stationary gear <input type="checkbox"/> <input type="checkbox"/> Thrust bearing oil slinger <input type="checkbox"/> <input type="checkbox"/> Pinion roller <input type="checkbox"/> <input type="checkbox"/> Pinion gear <input type="checkbox"/> <input type="checkbox"/> Pinion gear drive plate <input type="checkbox"/> <input type="checkbox"/> Pinion cage <input type="checkbox"/> <input type="checkbox"/> Stationary gear drive plate <input type="checkbox"/> <input type="checkbox"/> Supercharger shaft gear

ISSUED			REVISED			PAGE NO.	REVISION	S.B. 533
MO	DAY	YEAR	MO	DAY	YEAR	12 of 16	C	
06	29	98	10	18	16			

Engine Inspection Checklist After Propeller Strike for All Lycoming Geared Engines (Cont.)

Sequential Task		Additional Information	Corrective Action Done/Comments
26.	Complete the visual inspection and Fluorescent Penetrant Inspection (FPI) on the crankcase. Refer to the latest revision of Service Instruction No. SI-1285. Closely examine the forward crankcase bearing support and adjacent structure.	Record test results.	<input type="checkbox"/> Use crankcase <input type="checkbox"/> Replace crankcase
27.	Complete the visual inspection and FPI on the oil sump.	Record test results.	<input type="checkbox"/> Use oil sump <input type="checkbox"/> Replace oil sump
28.	Complete the visual inspection and FPI on the engine mounts and, if used, the lower mount rings (on helicopter engines).	Record test results.	<input type="checkbox"/> Use engine mounts <input type="checkbox"/> Replace engine mounts
29.	Complete the visual inspection and FPI on the accessory housing.	Record test results.	<input type="checkbox"/> Use accessory housing <input type="checkbox"/> Replace accessory housing
30.	Complete the visual inspection and FPI on the aluminum oil pump impeller.	Record test results.	<input type="checkbox"/> Use impeller <input type="checkbox"/> Replace impeller
NOTICE: Counterweight rollers and bushings must be replaced.			
31.	Complete the visual inspection and FPI on the tappets (not roller tappets) and lifters. Refer to the latest revision of Service Instruction No. SI-1011.	Record test results.	<input type="checkbox"/> Tappets/lifters acceptable <input type="checkbox"/> Replace tappets/lifters
32.	Complete the visual inspection and FPI on the reduction gear housing	Record test results.	<input type="checkbox"/> Use reduction gear housing <input type="checkbox"/> Replace reduction gear housing
33.	Complete the visual inspection and FPI on the supercharger housing (if equipped)	Record test results.	<input type="checkbox"/> Use supercharger housing <input type="checkbox"/> Replace supercharger housing
34.	Complete the visual inspection and FPI on the supercharger impeller	Record test results.	<input type="checkbox"/> Use supercharger impeller <input type="checkbox"/> Replace supercharger impeller
35.	Examine each magneto in accordance with the magneto manufacturer's instructions.	Record test results.	<input type="checkbox"/> Replace magneto
36.	Examine the pistons as per instructions in the applicable Lycoming manual and the latest revision of the Service Table of Limits - SSP-1776.	Record test results.	<input type="checkbox"/> Pistons acceptable <input type="checkbox"/> Replace pistons

ISSUED			REVISED			PAGE NO.	REVISION	S.B. 533
MO	DAY	YEAR	MO	DAY	YEAR			
06	29	98	10	18	16	13 of 16	C	

Engine Inspection Checklist After Propeller Strike for All Lycoming Geared Engines (Cont.)

Sequential Task		Additional Information	Corrective Action Done/Comments
37.	Refer to the latest revision of Service Bulletin No. SB-240 to identify any parts that must be replaced during engine assembly.	Record parts that must be replaced.	
38.	Install a new crankshaft gear retaining bolt and lockplate.	Refer to the latest revision of Service Bulletin No. SB-475.	
39.	Review the documents of all other engine-mounted accessories on the engine, propeller governor (if installed), etc. for instructions on what to do for components exposed to sudden engine stoppage.		
40.	Assemble and install the engine. Install the propeller and test the engine. Complete an operational check of the engine.	In accordance with instructions in the applicable Lycoming engine manuals, the latest revisions of the Service Table of Limits - SSP-1776 and Service Instruction No. SI-1427.	
41.	Record maintenance findings and any corrective action in the engine logbook.		

UNAIRWORTHY PARTS:

ADDITIONAL WORK/INSPECTIONS NECESSARY:

OUTCOME OF INSPECTION- SUMMARY NOTES:

ISSUED			REVISED			PAGE NO.	REVISION	S.B. 533
MO	DAY	YEAR	MO	DAY	YEAR	14 of 16	C	
06	29	98	10	18	16			

Connecting Rod Parallelism/Squareness Check

NOTICE: The connecting rod parallelism and squareness gage (Figure 1) is necessary for this check.

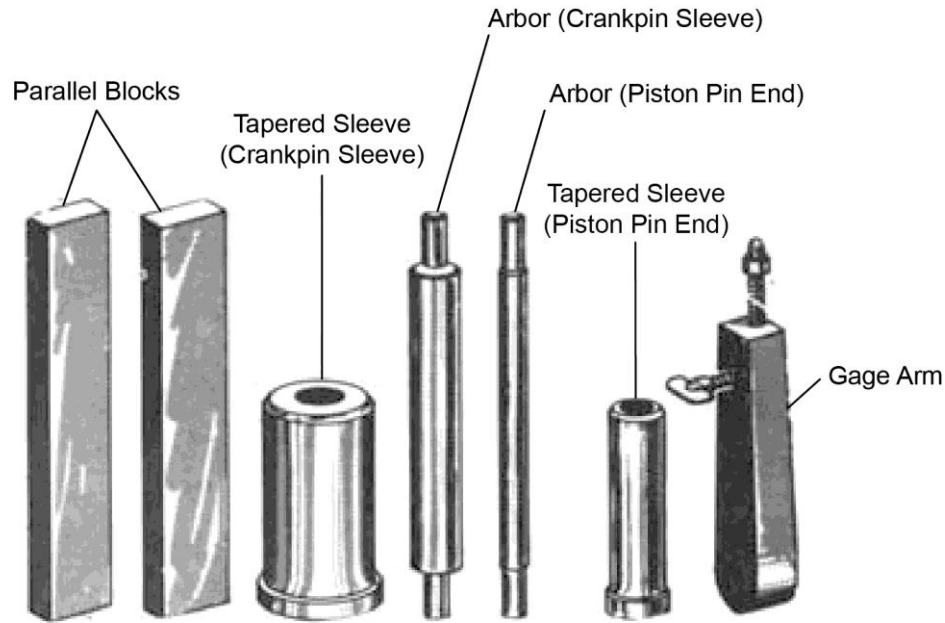

Figure 1
Connecting Rod Parallelism and Squareness Gage

- A. Verify that the bearing cap is assembled correctly and is tightened securely.
- B. Insert the tapered sleeves (Figure 2) of the Connecting Rod Parallelism and Squareness Gage in the bearing holes in the connecting rod.
- C. Pull arbors through the sleeves.
- D. Put the gage arm on the arbor.
- E. Turn the adjusting screw on the gage arm until it just contacts the arbor.
- F. Lock the adjusting screw with the wing nut.
- G. Make sure the adjusting screw just contacts the arbor.
- H. Remove the gage arm and place it on the other end of the arbor.
- I. Measure the distance between arbors. For exact parallelism or alignment, the distances measured on both sides are to be the same. Record the measurement.
- J. Remove the gage arm (Figure 2).
- K. Keep the sleeves and arbors in place.

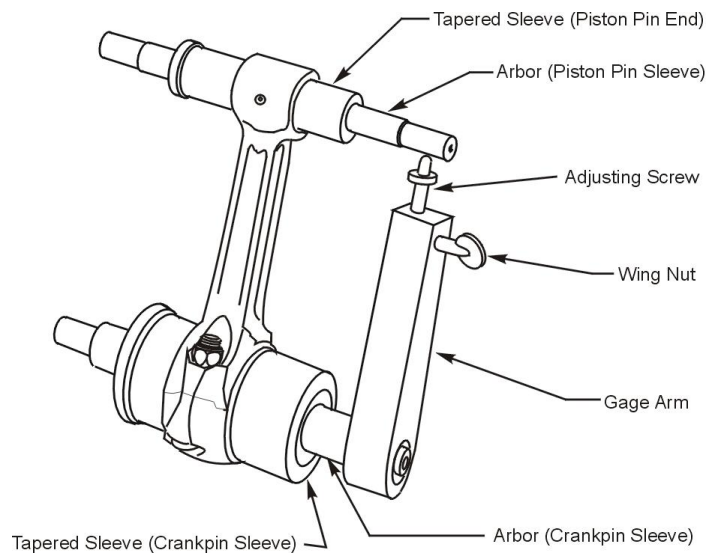

Figure 2
Parallelism Check of Connecting Rods

ISSUED			REVISED			PAGE NO.	REVISION	S.B. 533
MO	DAY	YEAR	MO	DAY	YEAR			
06	29	98	10	18	16	15 of 16	C	

- L. Put the parallel blocks (Figure 3) of the Connecting Rod Parallelism and Squareness Gage on the surface plate.
- M. Put the ends of the arbors on the parallel blocks.
- N. For the squareness or twist check, measure clearance at the four check points in Figure 3 where the arbors rest on the parallel blocks using a feeler gage. Record the measurement.
- O. Compare the clearance between each arbor and the parallel blocks against the values in the latest revision of the Service Table of Limits - SSP-1776. If out of tolerance, replace the connecting rods and examine the crankshaft to make sure the crankshaft is not damaged.

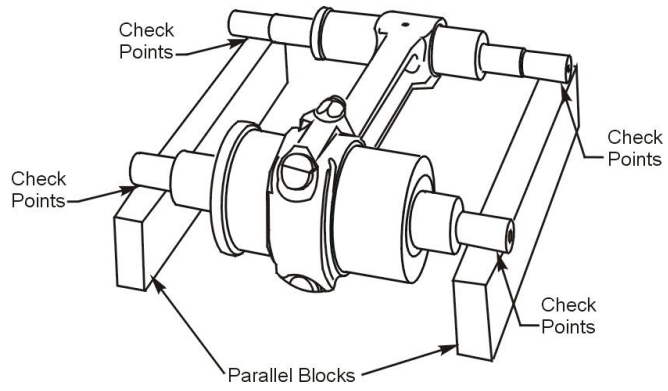

Figure 3
Squareness Check of Connecting Rods

ISSUED			REVISED			PAGE NO.	REVISION	S.B. 533
MO	DAY	YEAR	MO	DAY	YEAR			
06	29	98	10	18	16	16 of 16	C	