



652 Oliver Street
Williamsport, PA 17701 U.S.A.

Tel. 570-323-6181

Fax. 570-327-7101

www.lycoming.com

MANDATORY SERVICE BULLETIN

DATE: March 14, 2012 Service Bulletin No. 599
Engineering Aspects are
FAA Approved

SUBJECT: Compliance with Hartzell Engine Technologies, LLC (Previously Kelly Aerospace) Service Bulletin No. 045, 201F Fuel Pump Inspection and Recall

MODELS AFFECTED: New, rebuilt, or overhauled Lycoming engine models in Table A manufactured between May, 2010 and February, 2012 including those Lycoming engine models on Lycoming Special Advisory Nos. SA-103-611 (June 13, 2011) and SA-109-312 (March 7, 2012) with HET 201F series fuel pump installed.

Lycoming engine models field-overhauled or repaired with HET series 201F fuel pumps manufactured between January, 2002 and February, 2012.

TIME OF COMPLIANCE: Before further flight

NOTE

Incomplete review of all the information in this document can cause errors. Read the entire Service Bulletin to make sure you have a complete understanding of the requirements.

This Service Bulletin is notification for **mandatory compliance** with Hartzell Engine Technologies (HET), LLC (formerly Kelly Aerospace) Service Bulletin No. 045, 201F Fuel Pump Inspection and Recall. This Service Bulletin applies to those Lycoming engine models identified in Table A that could have a suspect new, rebuilt, or overhauled series 201F fuel pump made by HET.

NOTE

If you have completed the required action in HET's original Service Bulletin No. 041 and Service Bulletin No. 041 Rev. A as well as any required action in Lycoming Engines' Special Advisory Nos. SA-103-611 and SA-109-312, **you still must complete the required action in HET's Service Bulletin No. 045, 201F Fuel Pump Inspection and Recall.**

Record compliance with this Service Bulletin and HET's Service Bulletin No. 045 in your engine logbook.



ISSUED			REVISED			PAGE NO.	REVISION
MO	DAY	YEAR	MO	DAY	YEAR		
03	14	12	--	--	--	1 of 14	----

Table A
Non-Compliant Hartzell Engine Technologies, LLC
Fuel Pumps and Affected Lycoming Engines

Lycoming Part Number	Hartzell P/N	Lycoming Engine Models
62D26030	201F-5001	IO-540-G1B5, -G1D5, -J4A5, -R1A5 IO-720-A1A, -A1B
62D26031	201F-5002	LIO-320-C1A IO-720-A1A, -A1B
62D26032	201F-5003	IO-320-C1A, -F1A, -X141 IO-360-F1A IO-540-G1C5, -K1A5, -K1B5, -K1F5, -K1K5 HIO-540-A1A YIO-540-K1B5
62D26033	201F-5004	IO-360-C1F, -F1A TIO-360-A1B, -X209 YTIO-360-EXP
62D26034	201F-5005	IO-360-B1D IO-540-A1A5, -G1B5, -G1D5, -K1B5, -K1C5, -K1D5, -K1F5, -L1A5, -M1A5, -M1C5, -P1A5, -S1A5, TIO-540-A2B, -C1A, -E1A, -G1A, -H1A
62D26035	201F-5006	LIO-320-C1A HIO-360-E1AD, -E1BD, -F1AD TIO-360-C1A6D IO-540-K1A5D AEIO-540-L1B5D
62D26036	201F-5007	IO-540-L1B5D, -M2A5D TIO-540-AA1AD, -AB1AD, -AB1BD, -C1AD, -K1AD, -X136, -X164, -X216 AEIO-540-L1B5D
62D26037	201F-5008	TIO-540-AF1A, -AF1B, -AG1A, -AK1A, -X155

ISSUED			REVISED			PAGE NO.	REVISION	S.B. 599
MO	DAY	YEAR	MO	DAY	YEAR	2 of 14	--	
03	14	12	--	--	--			



2900 Selma Highway
 Montgomery, AL 36108 USA
 Tel: 334-386-5400 Fax: 334-386-5450

Service Bulletin

Bulletin No. 045

**201F Fuel Pump
 Inspection & Recall**

1. Planning Information

A. Effectivity*

- (1) Hartzell Engine Technologies LLC (HET) 201F Series Fuel Pump P/N's 201F-5001, 201F-5002, 201F-5003, 201F-5004, 201F-5005, 201F-5006, 201F-5007, and 201F-5008 as used on Lycoming engines listed in Table 1* of this service bulletin.
 - (a) Fuel pumps with serial number up to and including H-PBN065FP are affected. These fuel pumps were manufactured between January 2002 and February 2012.
 - (b) Fuel pumps with serial number H-PCN025FP and up are not affected. (Refer to Fig. 2)
 - (c) An affected fuel pump may be new, rebuilt, or overhauled.

* This Service Bulletin only addresses products for which HET holds FAA PMA approval. Your aircraft may have a similar HET or Kelly Aerospace manufactured product that has been installed under some other authority.

CAUTION: DO NOT USE OBSOLETE OR OUTDATED INFORMATION. PERFORM ALL INSPECTIONS OR WORK IN ACCORDANCE WITH THE MOST RECENT REVISION OF THE APPLICABLE AIRCRAFT AND/OR ENGINE MAINTENANCE MANUAL (MM) AND THIS SERVICE BULLETIN (SB). INFORMATION CONTAINED IN THE MM AND THE SB MAY BE SIGNIFICANTLY CHANGED FROM EARLIER REVISIONS. USE OF OBSOLETE INFORMATION MAY CREATE AN UNSAFE CONDITION THAT MAY RESULT IN DEATH, SERIOUS BODILY INJURY, AND/OR SUBSTANTIAL PROPERTY DAMAGE. REFER TO THE APPLICABLE MM INDEX AND THE HET WEBSITE FOR THE MOST RECENT REVISION LEVELS.

B. Concurrent Requirements

- (1) Compliance with the most current revision of HET SB 041.

C. Reason

- (1) Hartzell Engine Technologies LLC, manufactures the engine driven 201F series high pressure fuel pump used in several Lycoming engine applications. It has come to the attention of HET that shaft seal leaks have occurred due to manufacturing related issues. This condition is similar but not related to the previous condition addressed by the most current revision of HET SB 041.
- (2) Internal fit and clearance conditions may cause rotor rub. This will generate heat causing erosion of the bearing and damage to the shaft seal. This condition may occur in all affected pumps including those previously complying with the most current HET SB 041.
- (3) A damaged shaft seal may result in a fuel leak which may lead to a loss of engine power and it may pose a fire hazard. Fuel will be routed to drain ports in the pump mounting flange where an airframe provided drain may be attached.
- (4) Regulatory action in the form of an Airworthiness Directive (AD) is unknown.

ISSUED			REVISED			PAGE NO.	REVISION	S.B. 599
MO	DAY	YEAR	MO	DAY	YEAR			
03	14	12	--	--	--	3 of 14	--	

Service Bulletin

Bulletin No. 045

201F Fuel Pump Inspection & Recall

D. Description

- (1) This Service Bulletin is being issued to mandate a recall of affected HET 201F fuel pumps for inspection, repair, or replacement as may be required.

E. Compliance

- (1) All affected fuel pumps:
 - a. **Before Further Flight** or installation perform Fuel Pump Identification in accordance with the Accomplishment Instructions of this Service Bulletin.
- (2) If the fuel pump has been identified as affected by this Service Bulletin:
 - a. If the fuel pump TIS is less than one hundred (100) hours or TIS is unknown, as of the date of this Service Bulletin:
 - i. Perform the Leak Inspection in accordance with the Accomplishment Instructions of this Service Bulletin **Before Further Flight**.
 - ii. If a leak is not found and the POH/AFM permits continuous operation of the boost (emergency) fuel pump for takeoff operations, the aircraft may be operated for the next ten (10) hours or to the next annual inspection, whichever occurs first, provided the boost pump is operated during takeoff operations. Perform the Terminating Action in accordance with the Accomplishment Instructions.
 - iii. If the POH/AFM does NOT permit continuous operation of the boost (emergency) fuel pump for takeoff operations, perform Terminating Action in accordance with the Accomplishment Instructions **Before Further Flight**.
 - b. If the fuel pump TIS is equal to or greater than one hundred (100) hours as of the date of this Service Bulletin:
 - i. Perform the Leak Inspection in accordance with the Accomplishment Instructions of this Service Bulletin **Before Further Flight**.
 - ii. If a leak is not found, the unit may remain in service up to 12 months from the date of this Service Bulletin provided a Leak Inspection is performed every 50 hours TIS. Perform a Leak Inspection every 50 hours TIS.
 - iii. Perform the Terminating Action in accordance with the Accomplishment Instructions within 12 months of the date of this Service Bulletin.
 - c. If the 201F fuel pump is in inventory or not installed but in serviceable condition, used or unused with an affected serial number:
 - i. Return to HET in accordance with Corrective Action 3.C(2) of this Service Bulletin prior to installation or reinstallation on an engine.
- (3) Replacement of the fuel pump is terminating action for this Service Bulletin.

ISSUED			REVISED			PAGE NO.	REVISION	S.B. 599
MO	DAY	YEAR	MO	DAY	YEAR	4 of 14	--	
03	14	12	--	--	--			

Service Bulletin

Bulletin No. 045

201F Fuel Pump Inspection & Recall

- F. Approval
(1) FAA approval has been obtained on technical data in this publication that affects type design.
- G. Manpower
(1) Negligible for Identification and Inspection.
(2) Up to two hours labor for gaining access and Return to Service.*
* Per engine if used on twin engine aircraft.
- H. References
(1) Applicable aircraft POH/AFM.
(2) Aircraft maintenance manual (as applicable).
(3) Lycoming engine Service Instructions or maintenance manual (for applicable model).
- I. Other Publications Affected
(1) None
- J. Weight and Balance
(1) Not affected

2. Material Information*

(As applicable to engine application.)

A. New P/N	Description	Qty.
201F-5001	201F Fuel Pump, Engine Driven	(1) A/R**
201F-5002	201F Fuel Pump, Engine Driven	(1) A/R**
201F-5003	201F Fuel Pump, Engine Driven	(1) A/R**
201F-5004	201F Fuel Pump, Engine Driven	(1) A/R**
201F-5005	201F Fuel Pump, Engine Driven	(1) A/R**
201F-5006	201F Fuel Pump, Engine Driven	(1) A/R**
201F-5007	201F Fuel Pump, Engine Driven	(1) A/R**
201F-5008	201F Fuel Pump, Engine Driven	(1) A/R**

* Additional airframe or engine parts may be required to support this service bulletin. These parts, if required, must be obtained from the airframe or engine manufacturer.

** Part may be new, rebuilt, overhauled, or repaired as determined by compliance type.

ISSUED			REVISED			PAGE NO.	REVISION	S.B. 599
MO	DAY	YEAR	MO	DAY	YEAR	5 of 14	--	
03	14	12	--	--	--			

Service Bulletin

Bulletin No. 045

201F Fuel Pump Inspection & Recall

3. Accomplishment Instructions

WARNING THIS PROCEDURE MUST BE PERFORMED BY COMPETENT AND QUALIFIED PERSONNEL WHO ARE FAMILIAR WITH ENGINE AND AIRFRAME MAINTENANCE THAT IS SPECIFIC TO THE ENGINE FUEL SYSTEM. FAILURE TO DO SO MAY RESULT IN ECONOMIC LOSS, EQUIPMENT DAMAGE, AND/OR PHYSICAL INJURY.

CAUTION 1 DO NOT USE OBSOLETE OR OUTDATED INFORMATION. PERFORM ALL INSPECTIONS OR WORK IN ACCORDANCE WITH THE MOST RECENT REVISION OF THIS SERVICE BULLETIN AND THE APPLICABLE AIRCRAFT, ENGINE AND/OR HET 200201-0000 (VOLUME 2) MAINTENANCE MANUAL. INFORMATION CONTAINED IN THESE MANUALS OR THIS SERVICE BULLETIN MAY BE SIGNIFICANTLY CHANGED FROM EARLIER REVISIONS. FAILURE TO COMPLY WITH THE SERVICE BULLETIN OR THE USE OF OBSOLETE INFORMATION MAY CREATE AN UNSAFE CONDITION THAT MAY RESULT IN DEATH, SERIOUS BODILY INJURY, AND/OR SUBSTANTIAL PROPERTY DAMAGE. REFER TO THE APPLICABLE AIRCRAFT, LYCOMING, AND/OR THE HET 200201-0000 (VOLUME 2) MAINTENANCE MANUAL INDEX FOR THE MOST RECENT REVISION LEVEL OF THE PUBLICATION.

CAUTION 2 DO NOT DEPEND ON THIS SERVICE BULLETIN FOR GAINING ACCESS TO THE AIRCRAFT OR ENGINE. ACCESS REQUIRES THE USE OF THE APPLICABLE MANUFACTURER'S MAINTENANCE MANUALS OR SERVICE INSTRUCTIONS. IN ADDITION, ANY PREFLIGHT OR IN FLIGHT OPERATIONAL CHECKS REQUIRE USE OF THE APPROPRIATE AFM OR POH.

A. Fuel Pump Identification

- (1) If positive identification of the fuel pump installation and fuel pump TIS can be made through the aircraft paperwork, continue with 3.A.(4)(a). If positive identification of the fuel pump and the fuel pump TIS cannot be made, continue with this instruction.
- (2) Access the aircraft engine driven fuel pump in accordance with the instructions in the applicable engine service instructions and aircraft maintenance manual.
- (3) Remove the cowling from the engine and locate the high pressure fuel pump on the particular model engine you are inspecting.
- (4) Locate the data tag on the fuel pump and determine if the unit is a fuel pump made by HET (or Kelly Aerospace).
 - (a) If the unit is NOT an HET (or Kelly Aerospace) 201F fuel pump, proceed to section 3.D(4) for return to service.
 - (b) If the unit IS an HET (or Kelly Aerospace) 201F series fuel pump, proceed with Compliance 1.E(2)a(ii) or 1.E(2)b(ii) as applicable.

ISSUED			REVISED			PAGE NO.	REVISION	S.B. 599
MO	DAY	YEAR	MO	DAY	YEAR			
03	14	12	--	--	--	6 of 14	--	

Service Bulletin

Bulletin No. 045

201F Fuel Pump Inspection & Recall

B. Fuel Leak Inspection

CAUTION: AN EXISTING FUEL LEAK WILL BE NOTICED AS BLUE OR BLUE GREEN STAINING IN THE VICINITY OF THE DRAIN PORT AND EXTENDING ONTO THE LOWER COWLING AND/OR FUSELAGE OR DRIPPING FROM THE DRAIN PORT. SHOULD ABNORMAL STAINING OR ANY FUEL LEAKAGE BE NOTICED, REGARDLESS OF REASON OR FUEL PUMP MAKE, MODEL, OR MANUFACTURER, THE CAUSE SHOULD BE INVESTIGATED. IF AUTO GAS IS BEING USED, NO STAINS MAY BE APPARENT. IN SUCH CASES, LEAK DETECTION MUST BE VISUALLY OBSERVED AS LIQUID AT THE OVERBOARD FUEL DRAIN

- (1) Inspect for fuel leakage from the fuel pump overboard drain. As some aircraft may put several drains together, leakage indication may not be caused by the fuel pump. To confirm that the fuel pump has a leak, the following must be accomplished:
 - (a) In a secure area, turn on electrical power, set fuel selector to fullest tank, and place the mixture in idle cutoff (ICO).
 - (b) Engage the fuel boost pump or auxiliary fuel pump and check for a positive indication of fuel pressure.
 - (c) Observe the overboard drain for fuel leakage. If leaking, turn off immediately.
 - (d) Most fuel pump overboard drains are located on the bottom cowl near the firewall. However, check with the specific AFM, POH, or maintenance manual for the aircraft for proper location.
 - (e) If a leak is found, stop aircraft operations immediately and proceed to section 3.C for Corrective Action.
 - (f) If leakage is NOT found, continued operation of the aircraft may be permissible in accordance with the provisions given in Compliance. Proceed to section 1.E(2)a(ii) or 1.E(2)b(ii) as applicable.

ISSUED			REVISED			PAGE NO.	REVISION	S.B. 599
MO	DAY	YEAR	MO	DAY	YEAR			
03	14	12	--	--	--	7 of 14	--	

Service Bulletin

Bulletin No. 045

201F Fuel Pump Inspection & Recall

CAUTION WHEN HANDLING FUEL, USE ALL PRECAUTIONS NECESSARY TO CONTAIN ANY SPILLED OR LEAKED FUEL AND LIMIT ACCESS TO ANYONE NOT ASSIGNED THE TASK OF THE TEST PROCEDURES HEREIN. DO NOT LOCATE THE AIRCRAFT BEING TESTED NEAR OPEN FLAME, HEAT SOURCES, ELECTRICAL SPARKS OR OTHER IGNITION SOURCES. FAILURE TO FOLLOW THESE PRECAUTIONS MAY CREATE AN UNSAFE CONDITION THAT MAY RESULT IN DEATH, SERIOUS BODILY INJURY, AND/OR SUBSTANTIAL PROPERTY DAMAGE.

C. Corrective Action:

- (1) Remove fuel pump from aircraft in accordance with engine and airframe service instructions. Retain all engine or airframe supplied fittings from the fuel pump prior to return. **(HET cannot return fittings to the customer.)**
- (2) Forward the affected fuel pump to the HET factory per the instructions contained in Appendix I - Commercial Assistance found at the end of this service bulletin.
 - (a) Upon receipt of the replacement pump, proceed to "Return to Service" 3.D.(1).

D. Return to Service

- (1) Install the fuel pump on the aircraft engine as prescribed in the latest revision of the aircraft or engine maintenance manual or service instructions.
- (2) Perform the recommended fuel pump functional tests in accordance with the appropriate aircraft maintenance manual, engine service instructions, and per operational test in the AFM or POH.
- (3) Using the applicable aircraft and engine manufacturer's maintenance manuals of the latest revision, install any portion of the aircraft that was removed to gain access.
- (4) The aircraft may be returned to service after making a logbook entry to indicate completion of this Service Bulletin as applicable:
 - (a) Inspection and noting the TIS limit for Terminating Action.
 - (b) Terminating Action by replacement of the applicable 201F fuel pump.

ISSUED			REVISED			PAGE NO.	REVISION	S.B. 599
MO	DAY	YEAR	MO	DAY	YEAR	8 of 14	--	
03	14	12	--	--	--			

Service Bulletin

Bulletin No. 045

201F Fuel Pump Inspection & Recall

4. Contact Information

- A. All communications regarding this Service Bulletin, must be placed either through Hartzell Engine Technologies Technical Support at (888) 461-6077 or via Fax (334) 386-5450. For the Warranty department, (334) 386-5441.
- B. Written communications must be placed through Hartzell Engine Technologies Technical Support, 2900 Selma Highway, Montgomery, AL 36108, USA.
- C. If E-mail communication is desired, go to our website:<http://www.hartzellenginetech.com> and select "contact" and follow the instructions.
- D. If returning the fuel pump for repair or replacement, return to:

Hartzell Engine Technologies LLC
2900 Selma Highway
Montgomery, AL 36108, USA.

Attention: Warranty / SB 045

ISSUED			REVISED			PAGE NO.	REVISION	S.B. 599
MO	DAY	YEAR	MO	DAY	YEAR			
03	14	12	--	--	--	9 of 14	--	

Service Bulletin

Bulletin No. 045

201F Fuel Pump Inspection & Recall

Figure 1 - 201F Inlet / Outlet & Drains (Typical)

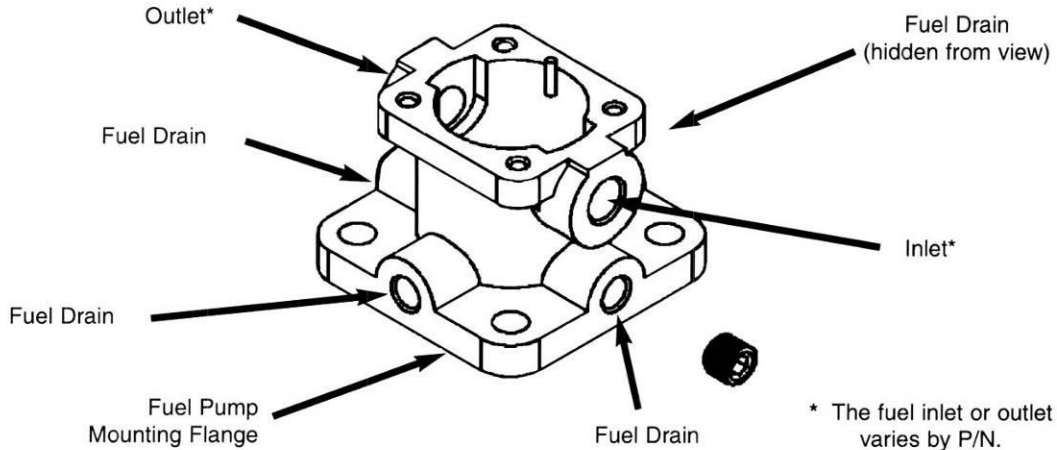

HET → H- P C N 025 FP R

Figure 2 - 201F Serial Number Breakdown

- Year Code
- Month Code
- Factory Code (no user info)
- 3-Digit Serial Number
- Fuel Pump (component type)
- Rebuilt /Overhauled*

Year Code	N = 2010, O = 2011, P = 2012, etc.
Month Code	A = January, B = February, C = March, etc.
Serial Number	3-Digit Sequential Number

Examples:

	Production:	Factory Rebuilt:
Part Number:	201F-5008	201F-5008R
Serial Number:	H-PCN025FP	H-PCN025FPR
Date of Mfg.:	March, 2012	March, 2012

ISSUED			REVISED			PAGE NO.	REVISION	S.B. 599
MO	DAY	YEAR	MO	DAY	YEAR	10 of 14	--	
03	14	12	--	--	--			

Service Bulletin

Bulletin No. 045

201F Fuel Pump Inspection & Recall

Table 1 - Cross Reference*

Part Number HET Fuel Pump	Part Number Textron Lycoming (Ref. Only)	Lycoming Engine Installation Eligibility
201F-5001	62D26030	IO-540-G1B5; IO-540-G1D5; IO-540-J4A5; IO-540-R1A5; IO-720-A1A; IO-720-A1B
201F-5002	62D26031	IO-720-A1A; IO-720-A1B
201F-5003	62D26032	IO-540-G1C5; IO-540-K1A5; IO-540-K1B5; IO-540-K1F5; IO-320-C1A; IO-320-F1A
201F-5004	62D26033	IO-360-A1B; TIO-360-A1B
201F-5005	62D26034	IO-540-A1A5; IO-540-G1B5; IO-540-G1D5; IO-540-K1C5; IO-540-K1D5; IO-540-K1F5; IO-540-L1A5; IO-540-P1A5; IO-360-B1D; TIO-540-A2B; TIO-540-C1A; TIO-540-E1A; TIO-540-G1A; TIO-540-H1A
201F-5006	62D26035	IO-540-K1A5D; TIO-360-C1A6D; LIO-320-C1A
201F-5007	62D26036	IO-540-M2A5D; TIO-540-AA1AD; TIO-540-AB1AD
201F-5008	62D26037	TIO-540-AF1A; TIO-540-AF1B

* This Service Bulletin only addresses products for which HET holds FAA PMA approval. Your aircraft may have a similar HET or Kelly Aerospace manufactured product that has been installed under some other authority that may not be listed in this table.

Rev. New: March 8/12
© 2012 - Hartzell Engine Technologies. - All rights reserved

SB 045
Page 9 of 10

ISSUED			REVISED			PAGE NO.	REVISION	S.B. 599
MO	DAY	YEAR	MO	DAY	YEAR	11 of 14	--	
03	14	12	--	--	--			

Service Bulletin

Bulletin No. 045

201F Fuel Pump Inspection & Recall

Intentionally Left Blank

SB 045
Page 10 of 10

Rev. New: March 8/12
© 2012 - Hartzell Engine Technologies. - All rights reserved

ISSUED			REVISED			PAGE NO.	REVISION	S.B. 599
MO	DAY	YEAR	MO	DAY	YEAR			
03	14	12	--	--	--	12 of 14	--	

APPENDIX I
COMMERCIAL ASSISTANCE:

In addition to warranty coverage provided by the HET Limited Warranty, HET will provide additional commercial assistance to comply with SB 045 under the terms outlined in this Appendix.

Commercial Assistance: the following will be provided with the submission of a completed PPCR (Attachment A, Sections I and II only) along with copies of invoices showing breakdown of labor charges and log book entries. This will serve as a claim form when received by HET warranty department.

If the unit is not sent to HET for replacement, commercial assistance will NOT be available for SB 045.

Identification: Labor is negligible.

Removal and Installation: Up to two (2) hours labor (up to \$150 maximum) per engine.
(includes gaining access) This assistance is for affected HET fuel pumps only, no assistance will allowed for others.

Leak Test Up to one (1) hour labor (up to \$75 maximum) per engine.
(only) This assistance is for affected HET fuel pumps only, no assistance will allowed for others.

Within North America for units sent to HET there will be no charge for this work and replacement unit will be returned shipping pre-paid by the same method as received.

Outside North America for units sent to HET there will be no charge for this work and replacement units will be returned shipping pre-paid, less any applicable duties, by the same method as received. Field repairs or overhauls are NOT acceptable in regard to this Service Bulletin, the affected pump must be returned. If more information is required, call +1 334 386 5441 or E-mail: warranty@hartzellenginetech.com

WARRANTY STATEMENT:

- A. The sole warranty for the actions within this Service Bulletin are contained in the HET Limited Warranty Policy issued with the purchase of each new or rebuilt 201F fuel pump (see terms and conditions therein).
- B. Commercial assistance may apply as stated in Appendix I. Attachment A of this Service Bulletin is required.
- C. Issuance of this Service Bulletin in no way constitutes an implied or expressed warranty of any kind.
- D. This publication does not imply or state any responsibility for the workmanship of any person or entity performing work or maintenance on the engine or aircraft fuel system.

SHIPPING INFORMATION: (when returning to HET)

The 201F fuel pump must be securely packed and packaged so no fluid will seep into the shipping container. A copy of "Attachment A" must have "Customer Information" and "Product or Component Information" sections filled out completely and be included inside the shipping container. The 201F fuel pump must be received assembled and undamaged to qualify for replacement. **Do not return pump with engine or airframe fittings as HET can not return them. The replacement pump will be shipped less fittings.** Address package to Hartzell Engine Technologies LLC, Warranty Department, 2900 Selma Highway, Montgomery, AL 36108, USA. Also mark "WARRANTY DEPT / SB 045" clearly on the outside of the shipping container. **HET will only pay for return shipping by the same method as received. (next day, ground, etc.)**

CONTACT INFORMATION:

All communications regarding this service bulletin, must be placed either through Hartzell Engine Technologies Technical Support at (888) 461-6077, or via Fax (334) 386-5450. For the Warranty department, (334) 386-5441. All telephone communications outside North America use +1 334 386 5441. Written communications must be placed through Hartzell Engine Technologies Technical Support, 2900 Selma Highway, Montgomery, AL 36108, USA.

If e-mail communication is desired, go to our website: <http://www.HartzellEngineTech.com> and select "contact" and follow the instructions.

ISSUED			REVISED			PAGE NO.	REVISION	S.B. 599
MO	DAY	YEAR	MO	DAY	YEAR			
03	14	12	--	--	--	13 of 14	--	

ATTACHMENT A - SB 045



PPCR

Publication Product Condition Report

(To validate warranty or commercial assistance, all information MUST be filled out.)

SECTION I: Customer information (Completed by End User)

Name: _____ Date of Report: _____ Tel: _____
 Company Name: _____ E-mail: _____
 Address: _____
 Aircraft Mfg/Engine: _____ Time in Service: _____ Model: _____ S/N: _____
 (as may be applicable)

SECTION II: Product or Component Information (Completed by End User)

Nomenclature: FUEL PUMP, 201F Part Number: _____
 Serial Number: _____ Batch/Date Code: _____
 Part Time in Service: _____

SECTION III: Compliance Information: (Completed by Repair Facility)

Compliance with SB-045: YES

Fuel Pump Leaks: YES NO

If yes, please describe condition of fuel pump and leak found:

Eligibility:

To be eligible for any commercial assistance, this form must be completed as instructed above and will serve as a claim form. NO reimbursement will be made without completing this form.

For further information contact Hartzell Engine Technologies LLC at: 2900 Selma Highway, Montgomery, AL, USA or FAX to HET Customer Service, 334-386-5450. The complete service bulletin is available to you online via our website at <http://www.HartzellEngineTech.com>. Rev. New: March 8/12

ISSUED			REVISED			PAGE NO.	REVISION	S.B. 599
MO	DAY	YEAR	MO	DAY	YEAR			
03	14	12	--	--	--	14 of 14	--	