

**TELEDYNE CONTINENTAL<sup>®</sup> AIRCRAFT ENGINE**  
**CRITICAL SERVICE BULLETIN**  
 Compliance Necessary To Maintain Safety

**CATEGORY 2**  
**CSB96-8**  
 FAA APPROVED  
 SUPERSEDES M92-16.

**SUBJECT: REPLACEMENT OF AIRMELT (NON-VAR) CRANKSHAFTS**

**PURPOSE:** Provide replacement requirements and identification methods for crankshafts.  
 This Service Bulletin supersedes M92-16 to incorporate additional engine models and expand the IO-520-F serial number affectivity. Additionally, clarification regarding inspection, identification and replacement criteria has been provided.

**COMPLIANCE:** Engine overhaul or whenever the crankshaft is removed or made accessible by crankcase disassembly.

**MODELS AFFECTED:** New, rebuilt and overhauled:  
 IO-360-A, AB, C, CB, D, DB, ES, G, GB, H, HB, J, JB, K, KB.  
 TSIO-360-A, AB, B, BB, C, CB, D, DB, E, EB, F, FB, G, GB, H, HB, JB, KB, LB, MB, RB.  
 LTSIO-360-E, EB, KB, RB.  
 IO-520-A, B, BA, C, D, E, F, J, K, L, M, P.  
 LIO-520-P.  
 TSIO-520-AE, AF, B, C, D, E, G, H, J, K, L, M, N, P, R, T, U.  
 LTSIO-520-AE.

**ACTION REQUIRED:** Inspect affected engine model crankshafts to determine if they are vacuum arc remelted (VAR) forgings whenever the crankshaft is removed or made accessible by crankcase disassembly. If the crankshaft cannot be identified as a VAR forging as set forth in the "IDENTIFICATION OF CRANKSHAFT" section of this Service Bulletin, it must be replaced with a new or serviceable VAR crankshaft.

**BACKGROUND INFORMATION**

In 1978 TCM began using VAR process steel in the forging of crankshafts for use in a number of its engines. The VAR process material produces a forging with fewer impurities providing the greatest reliability and resistance to unusual operating circumstances.

Field service data analysis suggests it is prudent to require replacement of all non-VAR crankshafts utilized in the affected engine models set forth in this Service Bulletin with VAR crankshafts. This replacement must be accomplished at engine overhaul or whenever the crankshaft is removed or made accessible by crankcase disassembly.

**DO NOT USE NON-VAR CRANKSHAFTS IN ANY ENGINE NOT AFFECTED BY THIS SERVICE BULLETIN UNLESS IT CAN BE SUBSTANTIATED THAT IT HAS NOT PREVIOUSLY OPERATED IN AN AFFECTED ENGINE.**

ISSUED			REVISED			 <b>TELEDYNE CONTINENTAL MOTORS</b> P.O. Box 90 • MOBILE ALABAMA 36601 334-438-3411	PAGE NO	REVISION
MO	DAY	YEAR	MO	DAY	YEAR		<b>1 of 6</b>	
06	25	96					CSB96-8	

## IDENTIFICATION OF CRANKSHAFT

Crankshafts made from VAR process steel are identified with the raised letters VAR forged into the crankshaft. The VAR forging identification is on the number 3, 7 or 9 crankshaft cheek depending on the crankshaft part number. The VAR forging identification may have been partially removed during the balancing process. If the crankshaft is identified as VAR, vibroetch the crankshaft flange with the letter "V". This "V" should follow the serial number and heat code. Make an appropriate entry in the engine log book.

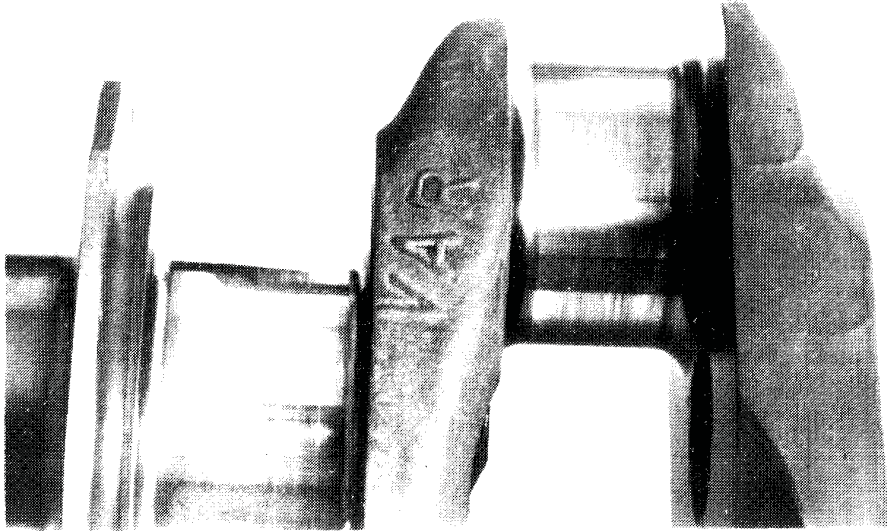



FIGURE 1



FIGURE 2

ISSUED			REVISED			 <b>TELEDYNE CONTINENTAL MOTORS</b> P.O. Box 90 • MOBILE ALABAMA 36601 334-438-3411	PAGE NO	REVISION
MO	DAY	YEAR	MO	DAY	YEAR		<b>2 of 6</b>	
06	25	96					CSB96-8	

- (a) Main Journal - M.J.
- (b) Rod Journal - R.J.
- (c) Crankshaft Cheek - C.C.

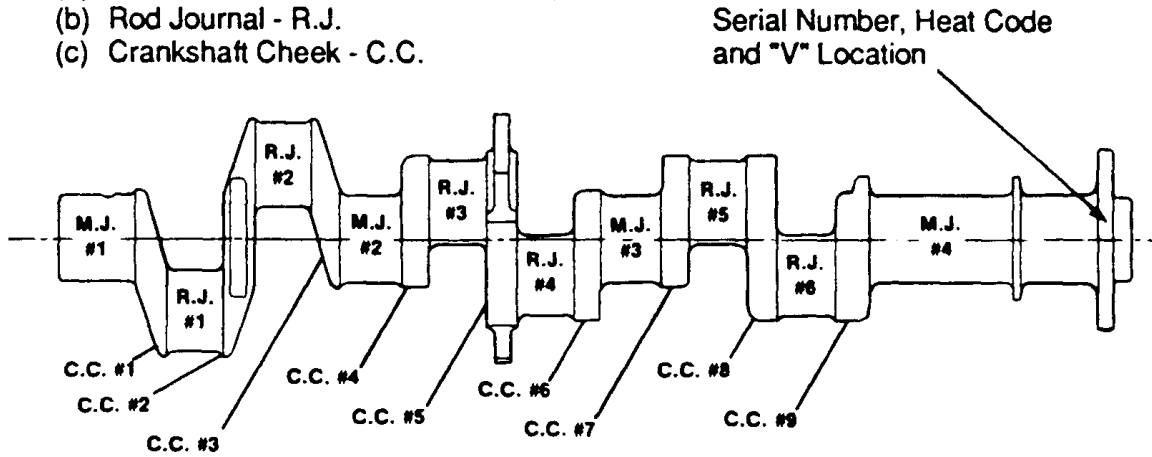

**FIGURE 3**

All crankshafts with the following serial number sequences were manufactured using VAR steel and are not affected by this bulletin. The serial number is stamped into the flange of the crankshaft.

**IMPORTANT...**The absence of a serial number impression on the crankshaft flange indicates a non-VAR crankshaft and the crankshaft must be removed from service at engine overhaul or whenever the crankshaft is removed from the crankcase. If a serial number stamped on the flange is different than described below, the crankshaft must be examined at next overhaul or when removed or made accessible by crankcase disassembly to determine whether the VAR identification is present on the number 3, 7 or 9 cheek. If no serial number or VAR identification is present the crankshaft must be replaced.

- S/N A001M1 and subsequent. (1981 through 1984)
- S/N 850001 and subsequent. (1985 through 1989)
- S/N A019001N and subsequent. (1990 and subsequent)

**SERIAL NUMBER INTERPRETATION**

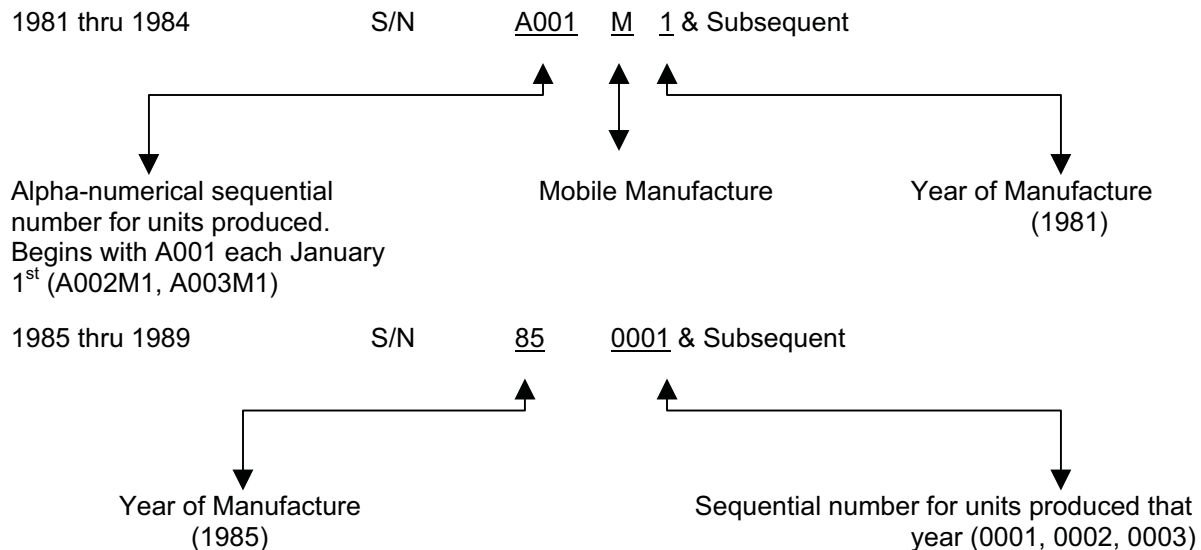

ISSUED			REVISED			 P.O. Box 90 • MOBILE ALABAMA 36601 334-438-3411	PAGE NO	REVISION
MO	DAY	YEAR	MO	DAY	YEAR		<b>3 of 6</b>	
06	25	96					CSB96-8	

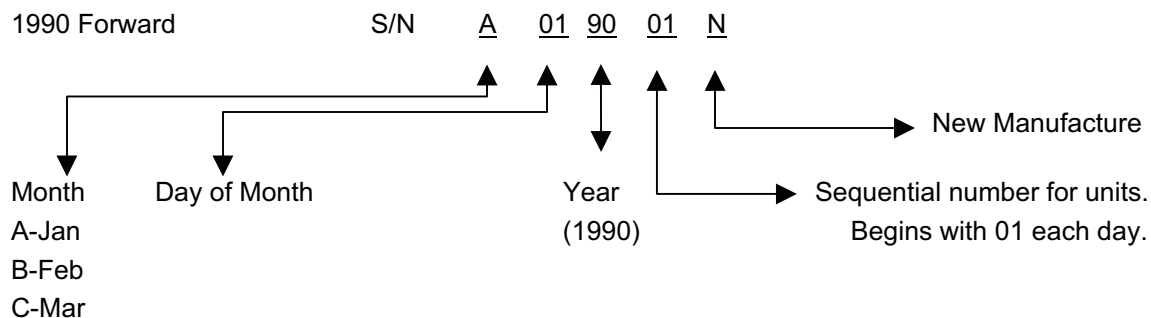

## REFERENCE INFORMATION

The following information is provided for reference only. All affected engine models must be inspected in accordance with the "ACTION REQUIRED" paragraph of this Service Bulletin.

- A. All TCM NEW ENGINES built on or after January 1, 1981, were originally manufactured with VAR crankshafts.
- B. All TCM REBUILT ENGINES with the following serial numbers and higher were originally manufactured with VAR crankshafts.

MODEL	SERIAL NUMBER
IO-360-A	020132-R
IO-360-C	060619-R
IO-360-CB	236518-R
IO-360-D	062961-R
IO-360-DB	239737-R
IO-360-ES	All
IO-360-G	244566-R
IO-360-GB	236675-R
IO-360-H	226557-R
IO-360-HB	265182-R
IO-360-J	238725-R
IO-360-K	240114-R
IO-360-KB	288506-R
TSIO-360-A	197105-R
TSIO-360-AB	237602-R
TSIO-360-C	283519-R
TSIO-360-CB	236179-R
TSIO-360-DB	238403-R
LTSIO-360-E	225646-R
TSIO-360-E	225137-R
LTSIO-360-EB	266368-R
TSIO-360-EB	265830-R
TSIO-360-F	232810-R
TSIO-360-FB	281111-R

ISSUED			REVISED			 <b>TELEDYNE CONTINENTAL MOTORS</b> P.O. Box 90 • MOBILE ALABAMA 36601 334-438-3411	PAGE NO	REVISION
MO	DAY	YEAR	MO	DAY	YEAR		4 of 6 CSB96-8	
06	25	96						

MODEL	SERIAL NUMBER
TSIO-360-GB	237428-R
TSIO-360-H	233267-R
TSIO-360-HB	239971-R
LTSIO-360-KB	268382-R
TSIO-360-KB	268148-R
TSIO-360-LB	247215-R
TSIO-360-MB	279230-R
TSIO-360-RB	All
LTSIO-360-RB	All
IO-520-A	112667-R
IO-520-B	234762-R
IO-520-BA	280802-R
IO-520-C	287054-R
IO-520-D	282793-R
IO-520-E	215782-R
IO-520-F	286302-R
IO-520-J	216519-R
IO-520-K	224073-R
IO-520-L	270349-R
IO-520-M	270799-R
IO-520-P	All
LIO-520-P	All
LTSIO-520-AE	246612-R
TSIO-520-AE	246113-R
TSIO-520-AF	245218-R
TSIO-520-B	176607-R
TSIO-520-C	178375-R
TSIO-520-D	180097-R
TSIO-520-E	275248-R
TSIO-520-G	216043-R
TSIO-520-H	217281-R
TSIO-520-J	218956-R
TSIO-520-K	224602-R
TSIO-520-L	241936-R
TSIO-520-M	283174-R
TSIO-520-N	228590-R
TSIO-520-P	278614-R
TSIO-520-R	269856-R
TSIO-520-T	239382-R

ISSUED			REVISED			 <b>TELEDYNE CONTINENTAL MOTORS</b> P.O. Box 90 • MOBILE ALABAMA 36601 334-438-3411	PAGE NO	REVISION
MO	DAY	YEAR	MO	DAY	YEAR		<b>5 of 6</b>	
06	25	96					CSB96-8	

C. All TCM FACTORY OVERHAULED engines with a serial number higher than S/N 901203-H were originally supplied with VAR crankshafts.

NOTE: Engines listed in A, B and C may have been overhauled or repaired after shipment from TCM and a non-VAR crankshaft installed.

Owners and operators are encouraged to regard the parameters which may affect crankshaft reliability. FAA advisory circular AC20-103 dated March 7, 1978, discusses these conditions and details preventive measures.

**CRANKSHAFT EXCHANGE POLICY**

TCM will accept serviceable non-VAR crankshafts for new VAR crankshafts on an exchange basis for the affected engine models set forth in this Service Bulletin. Non-VAR crankshafts that require replacement due to damage or wear are not eligible for exchange pricing. Contact your TCM Distributor for exchange pricing information.

**AFFECTED PUBLICATIONS:**

Insert a copy of this Service Bulletin into the appropriate section of the following manuals:

- Form # X30594A, IO-360 Overhaul Manual.
- Form # X30597A, TSIO-360 Overhaul Manual.
- Form # X30039A, IO-520 Series Overhaul Manual.
- Form # X30574A, TSIO-520 Permold Series Overhaul Manual.
- Form # X30575A, TSIO-520 Sandcast Series Overhaul Manual.

ISSUED			REVISED			 <b>TELEDYNE CONTINENTAL MOTORS</b> P.O. Box 90 • MOBILE ALABAMA 36601 334-438-3411	PAGE NO	REVISION
MO	DAY	YEAR	MO	DAY	YEAR		<b>6 of 6</b>	
06	25	96					CSB96-8	