

CONTINENTAL MOTORS® AIRCRAFT ENGINE
SERVICE INFORMATION DIRECTIVE

CATEGORY 4
SID97-4F

Compliance Will Enhance Safety, Maintenance or Economy of Operation

Supersedes SID97-4E
TECHNICAL PORTIONS
FAA APPROVED

SUBJECT: Cylinder Bore and Piston Fit Specifications
PURPOSE: Provide dimensional fits and limits for cylinders paired with manganese phosphate coated or non-coated pistons
COMPLIANCE: At cylinder repair, replacement, or engine major overhaul

MODELS

AFFECTED: New and Rebuilt: All inclusive models and specifications, C75, C85, C90, C115, C125, C145, O200, O300, GO300, IO240, IOF240, IO346, IO360, LTSIO360, TSIO360, O470, IO470, TSIO470, GTSIO520, IO520, LIO520, LTSIO520, TSIO520, IO550, IOF550, TSIO550, TSIOF550, and TSIO550

REASON FOR

REVISION: Incorporated Gold Standard cylinder dimensions and piston ring gaps

BACKGROUND INFORMATION

This service bulletin provides the following information:

1. Cylinder bore dimensions - New minimum/maximum, service limits (for continuing cylinders in service between major overhaul(s)) and oversize service limits.
2. Piston to cylinder clearance specifications for manganese phosphate coated or non-coated pistons.
3. Piston ring gaps and designated location in cylinder to measure ring gaps.
4. Piston diameters, piston skirt diameters, and pin to dome height dimensions.

The Gold Standard project streamlined many of the unique cylinder dimensional characteristics established through generations of product improvements to a common design specification shared with all engine models sharing the same cylinder bore size. Engine serial numbers 1006000 (and subsequent) and engine cylinder assemblies with part number 658XXX (and later) shall conform to the Gold Standard design specifications. In-service engines with earlier cylinder assembly part numbers may continue to use the pre-Gold standard specifications, where applicable, until cylinder replacement.

The “**New Limits MIN & MAX**” dimensions for **D, X, and Y** diameters identify cylinder barrel machining characteristics of new and authorized oversize (AO) dimension cylinders.

Only the **D** and the **X** diameters are used to determine the serviceability of the cylinder barrel. No wear limit is given for **Y** diameter because it is used for machining reference only.

For consistency, measure cylinder bore **D** and **X** dimensions in the plane through the spark plug holes; repeat at a right angle (90°) to the first measurement and then average the two results.

To determine out of round, measure first in the plane through the spark plug holes; repeat the measurement at a right angle (90°) to the first measurement and then subtract the smaller dimension from the larger. The difference must not exceed the out of round limit specified.

ISSUED	REVISED	 P.O. Box 90 Mobile, AL 251-436-8299	PAGE NO	DOC NO	REVISION
1997/03/24	2014/08/13		1 of 12	SID97-4	F

New or authorized oversize cylinder bore dimensions must be used at engine overhaul. Service limits may be used to return cylinders to service on engines that have not reached their published TBO. Do not return any cylinder to service that cannot be machined to conform to the dimensional limits specified in this service bulletin.

Piston ring gaps and cylinder dimensions must be maintained within the specifications provided in this bulletin. If the cylinder is machined to the next larger AO size, piston rings of the same AO size must be installed in the machined cylinder.

Piston specifications are presented in tabular form, (Table 18, page 11). Column 2, Non-coated pistons (with untreated skirt or graphite treated skirts pistons) were discontinued in 1998 and are provided for reference only.

Verify the cylinder, piston, and piston ring part numbers are the correctly specified part number for the installation. Installation of incorrect parts will cause engine damage and engine malfunction.

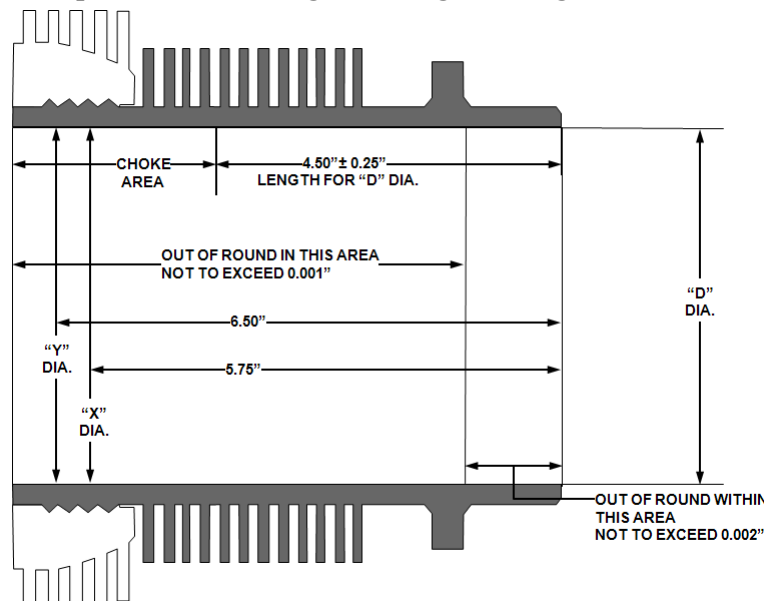

Figure 1. 5.250 Inch Cylinder Measurement Locations

Table 1. 5.250 Inch Cylinder Barrel Dimensions

Applicable to Pre-Gold Standard: IO520, GTSIO520, TSIO520, IO550, IOF550, TSIOL550
 Post-Gold Standard: IO346, IO520, LIO520, GTSIO520, LTSIO520, TSIO520, IO550, IOF550, TSIO550, TSIOF550, TSIOL550

Size	"D" Diameter (inches)			"X" Diameter (inches)			"Y" Diameter (inches)		
	Minimum	Maximum	Service Limit	Minimum	Maximum	Service Limit	Minimum	Maximum	Service Limit
STD.	5.251	5.253	5.256	5.247	5.250	5.257	5.244	5.247	N/A
.005	5.256	5.258	5.261	5.252	5.255	5.262	5.249	5.252	N/A
.010	5.261	5.263	5.266	5.257	5.260	5.267	5.254	5.257	N/A
.015	5.266	5.268	5.271	5.262	5.265	5.272	5.259	5.262	N/A

Cylinder bore out of round: new cylinder must not exceed 0.001" in barrel above flange; service limit must not exceed 0.003" at measured diameters.

Table 2. 5.250 Inch Cylinder Barrel Dimensions
Applicable to Pre-Gold Standard: IO346, TSIO550 (all except N), TSIOF550

Size	"D" Diameter (inches)			"X" Diameter (inches)			"Y" Diameter (inches)		
	Minimum	Maximum	Service Limit	Minimum	Maximum	Service Limit	Minimum	Maximum	Service Limit
STD.	5.252	5.254	5.257	5.248	5.251	5.258	5.245	5.248	N/A
.005	5.257	5.259	5.262	5.253	5.256	5.263	5.250	5.253	N/A
.010	5.262	5.264	5.267	5.258	5.261	5.268	5.255	5.258	N/A
.015	5.267	5.269	5.272	5.263	5.266	5.273	5.260	5.263	N/A

Cylinder bore out of round: new cylinder must not exceed 0.001" in barrel above flange; service limit must not exceed 0.003" at measured diameters.

Table 3. Piston to Cylinder Clearance
IO346, TSIO550, TSIOF550

5.250 Inch Piston	Piston in Cylinder (new)	
	Pre-Gold Standard	Post-Gold Standard
All Non-Coated	0.008 - 0.011 LOOSE	0.007 - 0.010 LOOSE
Manganese Phosphate Coated	0.009 - 0.012 LOOSE	0.008 - 0.011 LOOSE

Measure clearance perpendicular to piston pin bore at "D" diameter
Measure **below 4th ring groove** perpendicular to piston pin bore.

Table 4. Piston to Cylinder Clearance
IO520, LIO520, GTSIO520, LTSIO520, TSIO520, IO550, IOF550

5.250 Inch Piston	Piston in Cylinder (new)
All Non-Coated	0.008 - 0.011 LOOSE
Manganese Phosphate Coated	

Measure clearance perpendicular to piston pin bore at "D" diameter
Measure **below 4th ring groove** perpendicular to piston pin bore.

Table 5. Piston to Cylinder Clearance
TSIOL550

5.250 Inch Piston	Piston in Cylinder (new)
All Non-Coated	0.007 - 0.010 LOOSE
Manganese Phosphate Coated	0.008 - 0.011 LOOSE

Measure clearance perpendicular to piston pin bore at "D" diameter
Measure **below 4th ring groove** perpendicular to piston pin bore.

Table 6. Ring Gap Specifications
5.250 Inch Cylinder - All IO346, IO520, GTSIO520, LIO520, LTSIO520, TSIO520,
IO550, IOF550, TSIO550, TSIOF550, TSIOL550

RING	Part Number	Gaps				
		5.250 Gage Diameter	Pre-Gold Standard ¹	Pre-Gold Standard Service	Post-Gold Standard	Post-Gold Standard Service
Ring Set	654716A1	N/A	N/A	N/A	N/A	N/A
Top Ring	648005	0.026-0.034	0.032 -0.046	0.032 -0.055	0.029 - 0.043	0.029 - 0.052
Second Ring	654719	0.032-0.040	0.038 - 0.052 ²	0.038 - 0.061 ²	0.035 -0.049 ²	0.035 -0.058 ²
Oil Control Ring	654717 ³	0.012-0.022	0.018 - 0.034	0.018 - 0.043	0.015 -0.031	0.015 -0.040
Fourth Ring / Skirt	648008	0.012-0.022	0.018 - 0.034	0.018 - 0.043	0.015 -0.031	0.015 -0.040

1. Applies to Pre-Gold Standard piston ring gaps on IO346, TSIO550-C, E, G, K, and TSIOF550-D, J, K, and P.
2. Gap for second ring is nominally 0.006" larger than the top ring.
3. Part No. 654717 consists of expander (Part No. 654718) and ring (Part No. 649250-1).

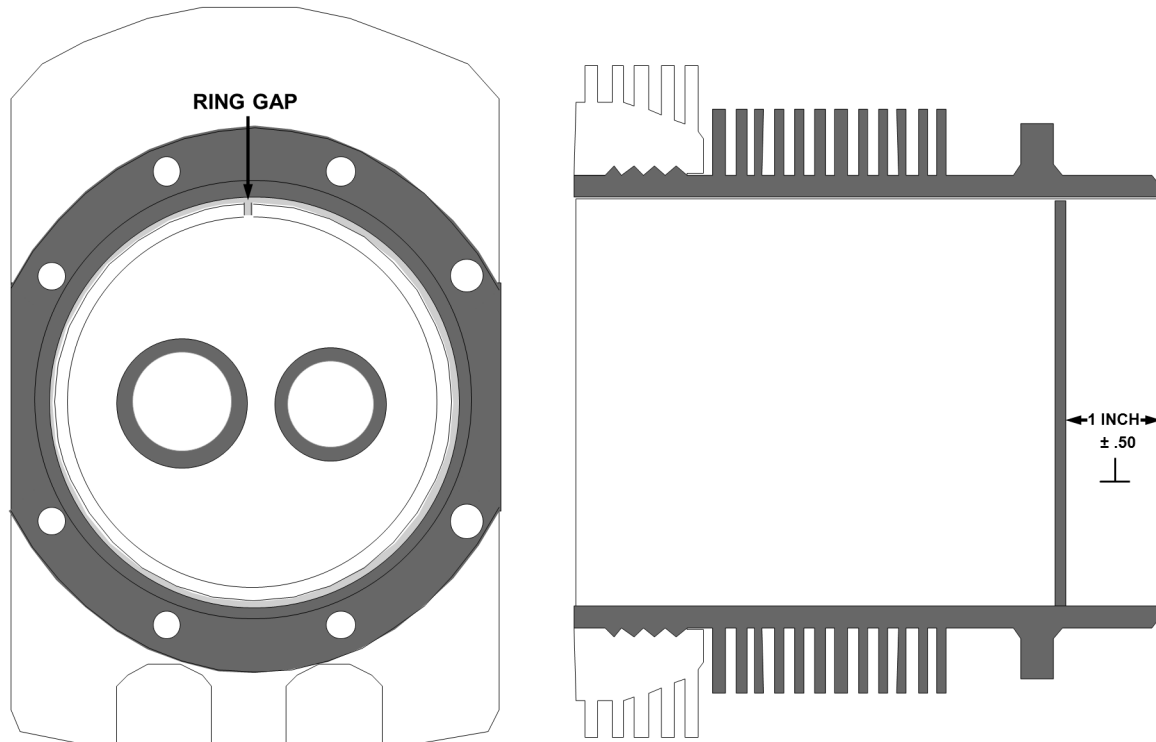

Figure 2. Ring Gap Measurement Location

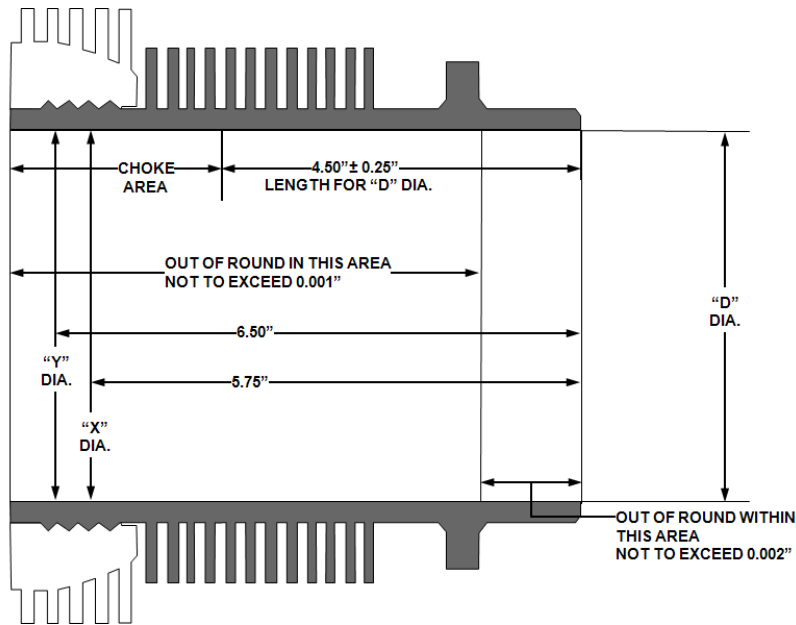

Figure 3. 5.000 Inch Cylinder Measurement Locations

**Table 7. 5.000 Inch Cylinder Barrel Dimensions
Applicable to E-Series: O470, IO470, TSIO470**

Size	"D" Diameter (inches)			"X" Diameter (inches)			"Y" Diameter (inches)		
	Minimum	Maximum	Service Limit	Minimum	Maximum	Service Limit	Minimum	Maximum	Service Limit
STD.	5.001	5.003	5.006	4.997	5.000	5.007	4.994	4.997	N/A
.005	5.006	5.008	5.011	5.002	5.005	5.012	4.999	5.002	N/A
.010	5.011	5.013	5.016	5.007	5.010	5.017	5.004	5.007	N/A
.015	5.016	5.018	5.021	5.012	5.015	5.022	5.009	5.012	N/A

Cylinder bore out of round: new cylinder must not exceed 0.001" in barrel above flange; service limit must not exceed 0.003" at measured diameters.

**Table 8. Piston to Cylinder Clearance
All O470 Series (except O470-K, L, R, & S), IO470, TSIO470-B, C, & D**

5.000 Inch Piston	Piston in Cylinder (new)
All Non-Coated	0.011 - 0.014 LOOSE
Manganese Phosphate Coated	
Measure clearance perpendicular to piston pin bore at "D" diameter Measure O470 and IO470 at the piston pin centerline perpendicular to piston pin bore. Measure TSIO470 at the bottom of piston skirt perpendicular to piston pin bore.	

**Table 9. Piston to Cylinder Clearance
E-Series, O470-K, L, R, & S**

5.000 Inch Piston	Piston in Cylinder (new)
All Non-Coated	0.009 - 0.012 LOOSE
Manganese Phosphate Coated	
Measure clearance perpendicular to piston pin bore at "D" diameter Measure at the bottom of piston skirt perpendicular to piston pin bore.	

Table 10. Ring Gap Specifications
5.000 Inch Cylinder - All O470, IO470, TSIO470

RING	Part Number	5.000 Gage Diameter	Gap	Service Gap
Ring Set, 6 cyl.	649226A1	N/A	N/A	N/A
Top Ring	648009	0.024 - 0.032	0.027 - 0.041	0.027 - 0.050
Second Ring	648010	0.020 - 0.030	0.023 - 0.039	0.023 - 0.048
Oil Control Ring	648011	0.012 - 0.022	0.015 - 0.031	0.015 - 0.040
Fourth Ring / Skirt	648012	0.012 - 0.022	0.015 - 0.031	0.015 - 0.040

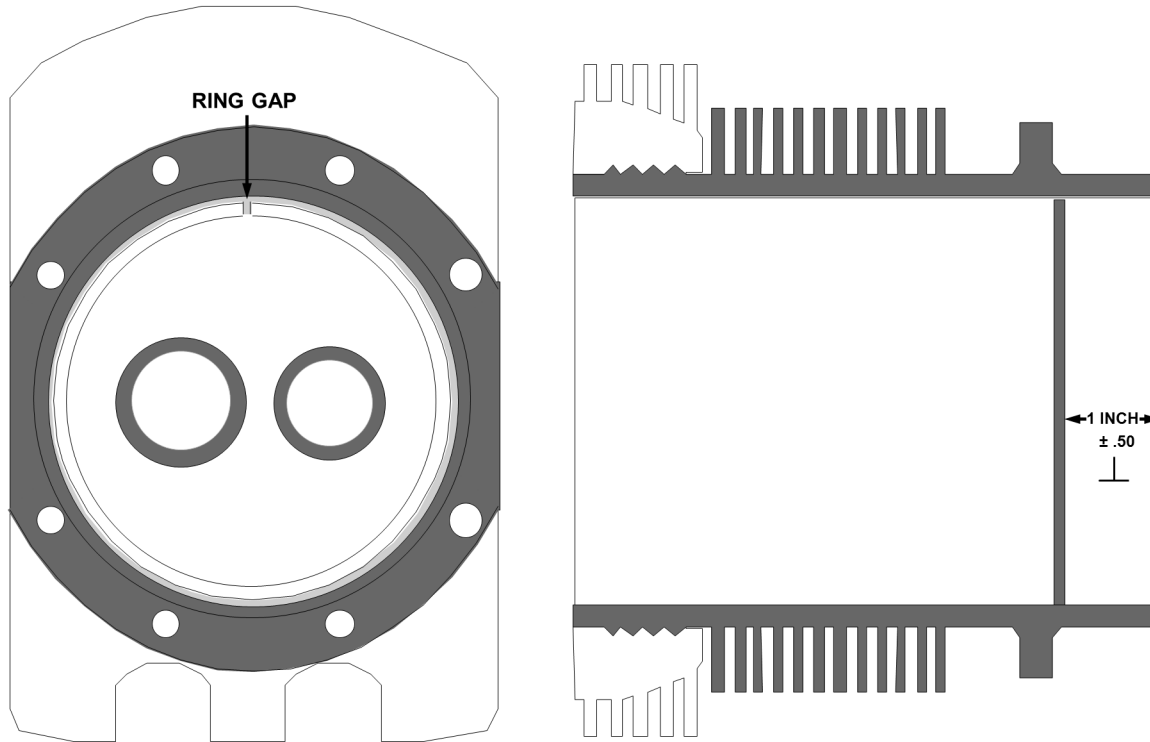

Figure 4. Ring Gap Measurement Location

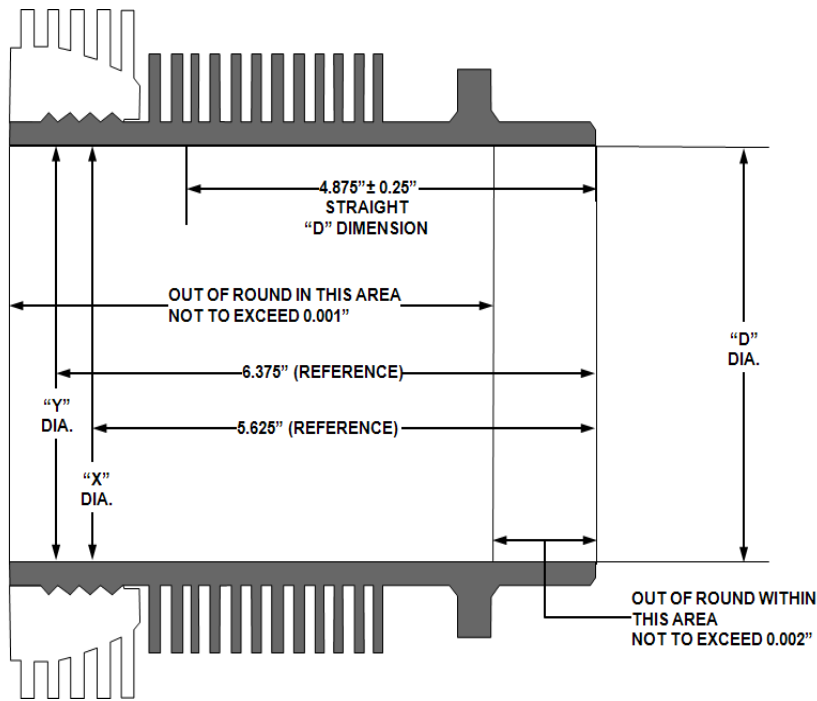

Figure 5. 4.438 Inch Cylinder Measurement Locations

Table 11. 4.438 Inch Cylinder Barrel Dimensions
Applicable to ALL IO240, IOF240, IO360, LTSIO360, and TSIO360

Size	"D" Diameter (inches)			"X" Diameter (inches)			"Y" Diameter (inches)		
	Minimum	Maximum	Service Limit	Minimum	Maximum	Service Limit	Minimum	Maximum	Service Limit
STD.	4.437	4.439	4.442	4.434	4.437	4.444	4.431	4.434	N/A
.005	4.442	4.444	4.447	4.439	4.442	4.449	4.436	4.439	N/A
.010	4.447	4.449	4.452	4.444	4.447	4.454	4.441	4.444	N/A
.015	4.452	4.454	4.457	4.449	4.452	4.459	4.446	4.449	N/A

Cylinder bore out of round: new cylinder must not exceed 0.001" in barrel above flange; service limit must not exceed 0.003" at measured diameters.

Table 12. Piston to Cylinder Clearance
Applicable to ALL IO240, IOF240, LTSIO360, IO360, and TSIO360

4.438 Inch Piston	Piston in Cylinder (new)
All Non-Coated	0.009 - 0.012 LOOSE
Manganese Phosphate Coated	
Measure clearance perpendicular to piston pin bore at "D" diameter Measure at the piston pin centerline perpendicular to piston pin bore.	

Table 13. Ring Gap Specifications
ALL IO240, IOF240, IO360, LTSIO360, and TSIO360

RING	Part Number	4.4375 Gage Diameter	Gap	Service Gap
Ring Set, 4 cyl. Ring Set, 6 cyl.	649225A2 649225A1	N/A N/A	N/A N/A	N/A N/A
Top Ring	648039	0.024 - 0.032	0.022 - 0.037	0.022 - 0.046
Second Ring	648040	0.030 - 0.038 ¹	0.028 - 0.043 ¹	0.028 - 0.052 ¹
Oil Control Ring	648041	0.010 - 0.020	0.008 - 0.025	0.008 - 0.034
Fourth Ring / Skirt	648042	0.012 - 0.022	0.008 - 0.025	0.008 - 0.034

1. Gap for second ring is nominally 0.006" larger than the top ring

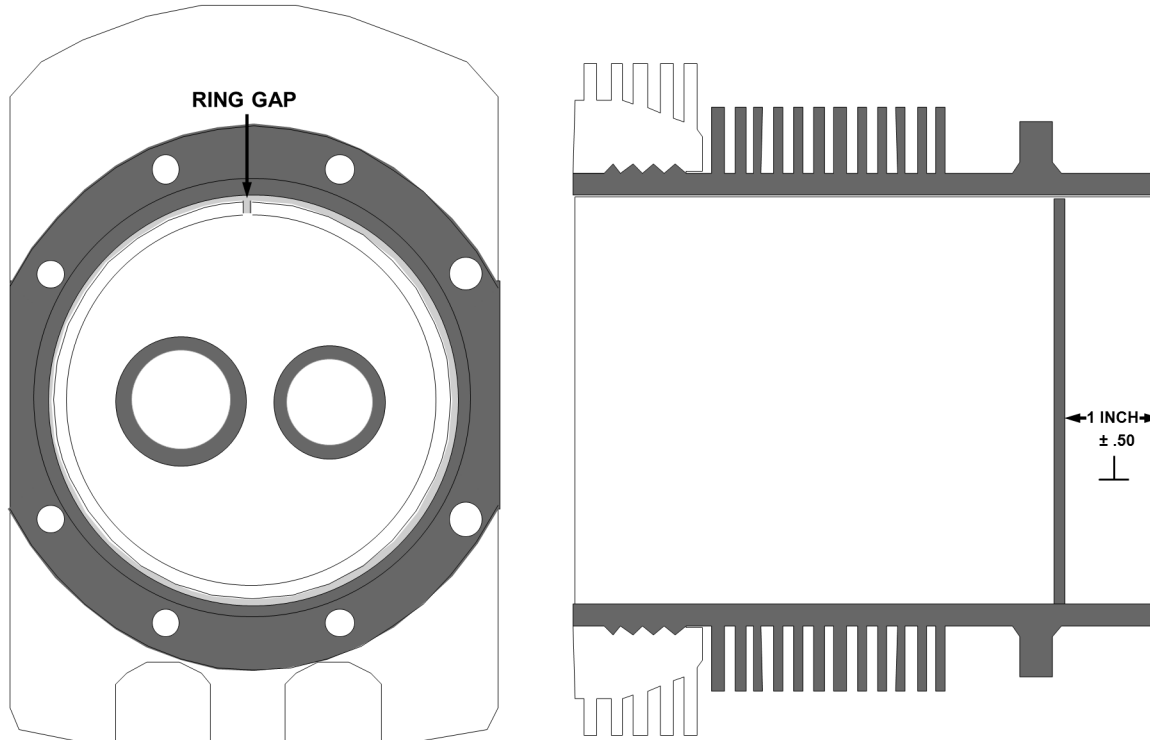

Figure 6. Ring Gap Measurement Location

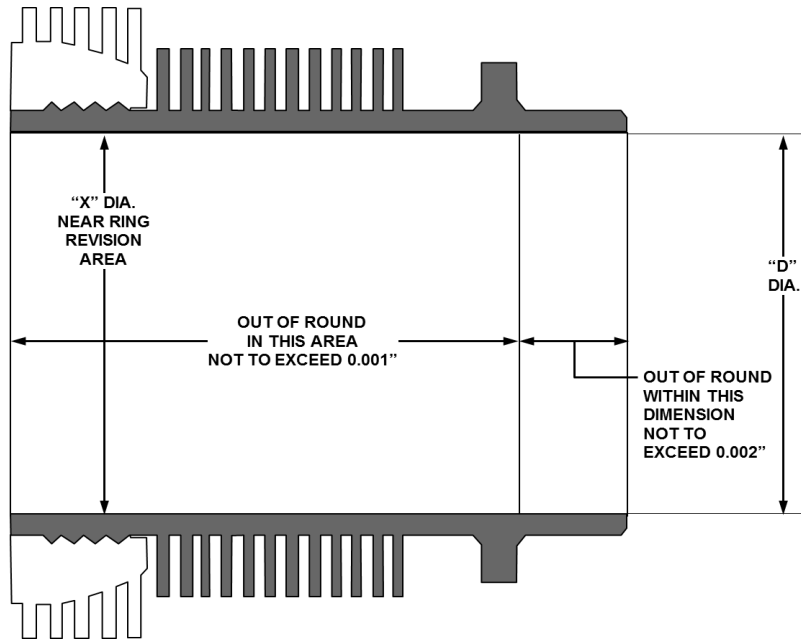

Figure 7. 4.062 Inch Cylinder Measurement Locations

**Table 14. 4.062 Inch Cylinder Barrel Dimensions
Applicable to C75, C85, C90, C115, C125, C145, O200, O300, GO300**

Size	"X" Diameter (inches)			Straight Barrel
	Minimum	Maximum	Service Limit	No Choke
STD.	4.0615	4.0635	4.0665	N/A
.005	4.0665	4.0685	4.0715	
.015	4.0765	4.0785	4.0815	

Cylinder bore out of round: new cylinder must not exceed 0.001" in barrel above flange; service limit must not exceed 0.003" at measured diameters.

**Table 15. Piston to Cylinder Clearance
Applicable to C75, C85, C90, C115, C125, C145, O200, O300, GO300**

4.062 Inch Piston	Piston in Cylinder (new)
All Non-Coated	0.009 - 0.012 LOOSE
Manganese Phosphate Coated	

Measure clearance perpendicular to piston pin bore at "D" diameter.
Measure C75, C85, C115, and C125 at the **bottom** of piston skirt perpendicular to piston pin bore.
Measure C90, C145, O200, O300 and GO300 **above 4th ring** perpendicular to piston pin bore.

Table 16. Ring Gap Specifications
Applicable to C75, C85, C90, C115, C125, C145, O200-A, B, & C, O300, GO300

RING	Part Number	4.0625 Gage Diameter	Gap	Service Gap
Ring Set, 4 cyl. Ring Set, 6 cyl	649632A2 649632A3	N/A N/A	N/A N/A	N/A N/A
Top Ring	649632	0.023 -0.031	0.020 -0.034	0.020 -0.043
Second Ring	638110	0.029 - 0.037	0.026 - 0.040	0.026 - 0.049
Third Ring	638110	0.029 - 0.037	0.026 - 0.040	0.026 - 0.049
Oil Control Ring	638111	0.015 - 0.025	0.012 - 0.028	0.012 - 0.037

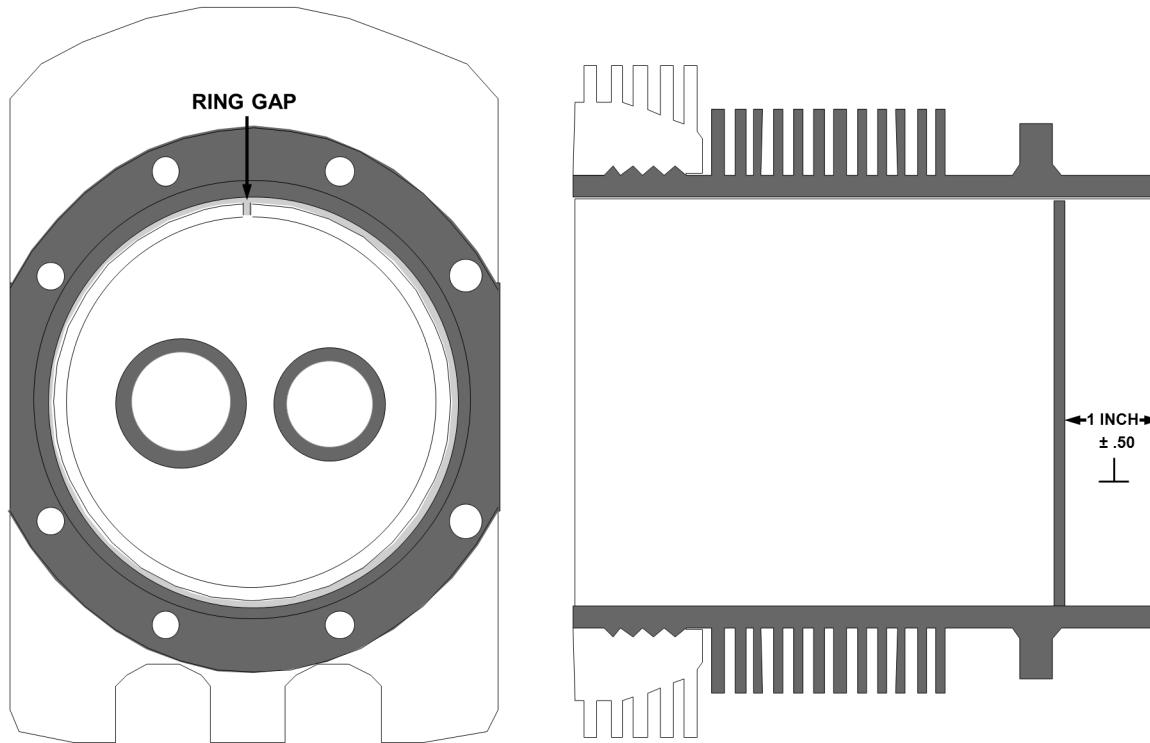

Figure 8. Ring Gap Measurement Location

Table 17. Ring Gap Specifications
O200D ONLY

RING	Part Number	4.0625 Gage Diameter	Gap	Service Gap
Ring Set	657480	N/A	N/A	N/A
Top Ring	657479	0.023 -0.031	0.020 -0.034	0.020 -0.043
Second Ring	638110	0.029 - 0.037	0.026 - 0.040	0.026 - 0.049
Third Ring	657548	0.015 - 0.025	0.012 - 0.028	0.012 - 0.037

Table 18. Engine to Piston Cross Reference

NOTE: *Non-coated pistons (with untreated skirt or graphite treated skirt) were discontinued in 1998 and are provided for reference only.

Engine Model	Non-coated Piston		Manganese Phosphate Coated Piston	Piston Diameter
	*untreated skirt	*graphite treated skirt		
C75, C85, C115, C125 (6.3:1 comp. ratio)	646287	N/A	654841	4.0514-4.0524
	N/A		654841P015	4.0664-4.0674
C90, C145 O200A, B O300A, C, D	N/A	654749	654853	4.0522-4.0532
		N/A	654853P015	4.0672-4.0682
O200D	N/A	N/A	657562	4.0522-4.0532
GO300	646279	N/A	654858	4.0522-4.0532
IO240A, B; IOF240B IO360A, AB, C, CB, D, DB, ES, G, GB, H, HB, J, JB, K, KB	648049	654728	654861	4.4270-4.4280
	N/A	N/A	654861P015	4.4420-4.4430
IO346A TSIO550B, C, E, G, K, N TSIOF550D, J, K, P TSIOL550A, B, C	N/A	N/A	657989	5.2422-5.2432
			657989P005	5.2472-5.2482
			657989P010	5.2522-5.2532
			657989P015	5.2572-5.2582
	649805	654731	N/A	5.2432-5.2442
	649805P005	654731P005		5.2482-5.2492
	649805P010	654731P010		5.2532-5.2542
649805P015	654731P015		5.2582-5.2592	
LTSIO360E, EB, KB, RB TSIO360A, AB, C, CB, D, DB, E, EB, F, FB, GB, H, HB, JB, KB, LB, MB, RB, SB	648048	654727	654859	4.4270-4.4280
	N/A	N/A	654859P015	4.4420-4.4430
O470K, L, R, S	646263	654744	654833	4.9907-4.9922
	N/A	N/A	654833P015	5.0057-5.0072
O470U IO470D, E, F, H, L, M, N, S, U, V	648029	654722	654832	4.9887-4.9897
	N/A	N/A	654832P015	5.0037-5.0047
O470G, M O470GC1 IO470C	648028	654721	654829	4.9887-4.9897
IO470K, J	649044	654729	654862	4.9887-4.9897
	N/A	N/A	654832P015	5.0037-5.0047
TSIO470B, C, D	N/A	N/A	655988	4.9887-4.9897
GTSIO520C, D, H, K, L, M, N TSIO520AF, B, BB, BE, C, CE, D, DB, E, EB, G, H, J, JB, K, KB, L, LB, M, N, NB, P, T, UB, VB, WB	648044	654724	654840	5.2420-5.2430
	N/A	N/A	654840P010	5.2520-5.2530
			654840P015	5.2570-5.2580
IO520A, B, BA, BB, C, CB, D, E, F, J, K, L, M, MB, N, NB	648045	N/A	654850	5.2420-5.2430
	N/A		654850P010	5.2520-5.2530
			654850P015	5.2570-5.2580

Table 18. Engine to Piston Cross Reference

NOTE: *Non-coated pistons (with untreated skirt or graphite treated skirt) were discontinued in 1998 and are provided for reference only.

Engine Model	Non-coated Piston		Manganese Phosphate Coated Piston	Piston Diameter
	*untreated skirt	*graphite treated skirt		
IO520P	648037	654723	654836	5.2420-5.2430
LIO520P	N/A	N/A	654836P010	5.2520-5.2530
LTSIO520AE TSIO520AE			654836P015	5.2570-5.2580
IO550A, B, C, D, E, F, G, L, N, P, R IOF550G, N, P & R	648046	654726	654857	5.2420-5.2430
	N/A	N/A	654857P010	5.2520-5.2530
			654857P015	5.2570-5.2580