

THE X-Y-G METRIC CAR WAS DESIGNED TO GIVE THE RACERS AN OPTION TO REPAIR THE GM-METRIC 108" FRAME WITHOUT HAVING TO TAKE A DAY OFF FROM WORK AND HUNT THROUGH JUNKYARDS FOR OBSOLETE AND NEARLY EXTINCT GM-METRIC PARTS TO TRY AND RETURN NEXT WEEK.

SEVERAL TRACKS WERE CONCERN ABOUT DWINDLING CAR COUNTS AND THE AVAILABILITY, AND RISING COST OF THE NOW CLASSIC AND HARD TO FIND PARTS.

TUBULAR WAS AN OPTION BUT HOW DO YOU GO TUBULAR WITHOUT OBSOLETING THE THOUSANDS OF GM METRIC RACECARS THAT ARE STILL IN GOOD SHAPE AND RACING WEEKLY.

X-Y-G METRIC IS AN EXACT REPLACEMENT FOR A DIGITALLY REVERSE ENGINEERED GM METRIC FRAME TO EXACT OEM WEIGHTS AND DIMENSIONS ALL DIMENSIONS ON THE FRAME HAVE AN EXACT X-Y-Z MEASUREMENT HENCE DOUBLED THE NAME X-Y-G METRIC.

INSPECTION BLUEPRINTS ARE AVAILABLE TO SANCTIONS AND RACETRACKS

THE INTEGRITY OF THE X-Y-G METRIC PROJECT IS MAINTAINED BY THE

“WATCHDOG INSPECTION SYSTEM”
CURRENTLY USED AT SEVERAL SPEEDWAYS

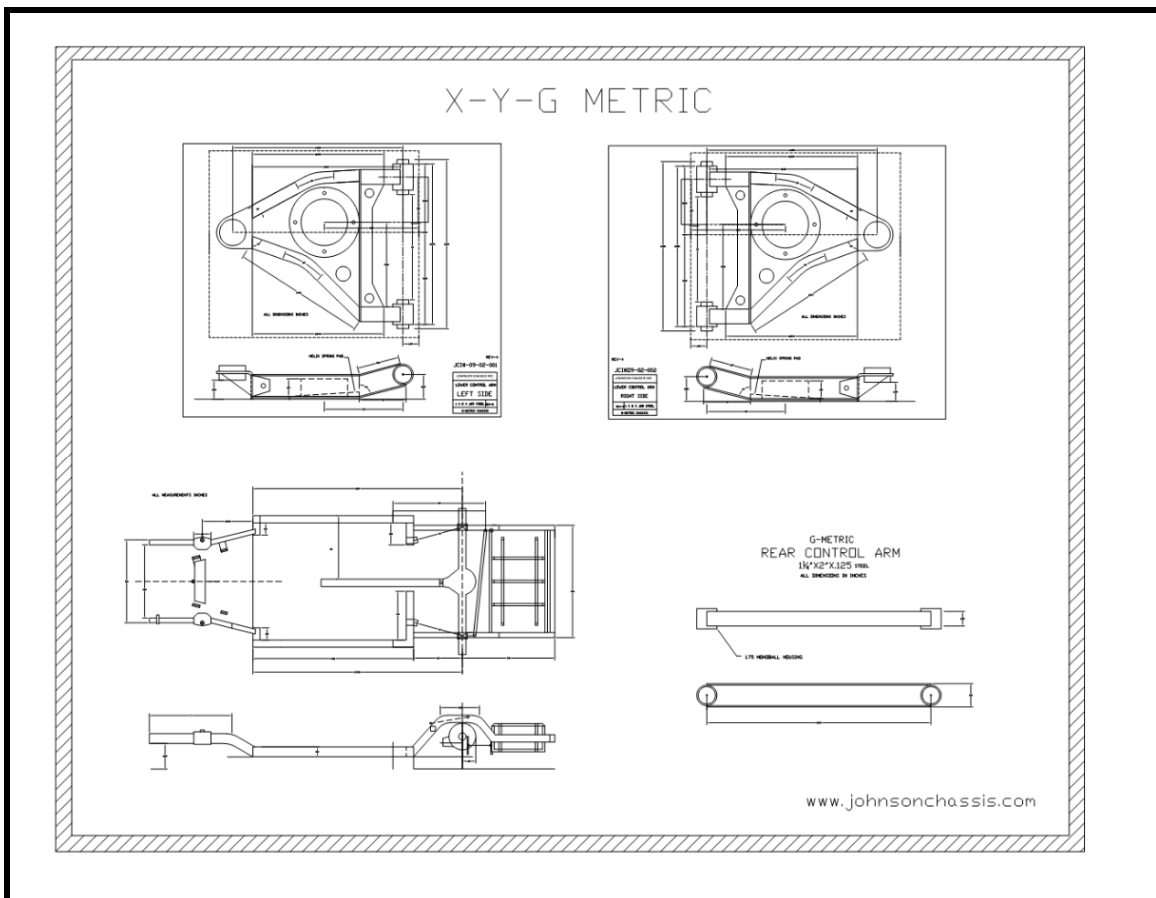

MORE INFORMATION AND A FULL CATALOG CAN BE VIEWED DOING A GOOGLE SEARCH OF JOHNSON CHASSIS. THERE ARE BLOGS AND CHATS WITH CHATTER ABOUT THE PROJECT

WWW.JOHNSONCHASSIS.COM IS OUR WEB-SITE

WE HAVE SEVERAL DEALERS IN THE USA AND CANADA

WITH ALMOST 10 SEASONS INTO THE PROJECT WE ARE EXPERIENCING THE SUCCESS WE INTENDED THE PARTS ARE REPLACEMENTS NOT IMPROVEMENTS.

YOU WILL NOT GO FASTER OR SLOWER THAN YOU DO RIGHT NOW.

YOU WILL JUST BE ABLE TO RETURN NEXT WEEK WITH ONE PHONE CALL

THE FOLLOWING PAGES HAVE A SUMMARY
OF THE PARTS AVAILABLE



WELDS TO STOCK FRAME OR TUBULAR FRAME IN APPROX 4 HOURS

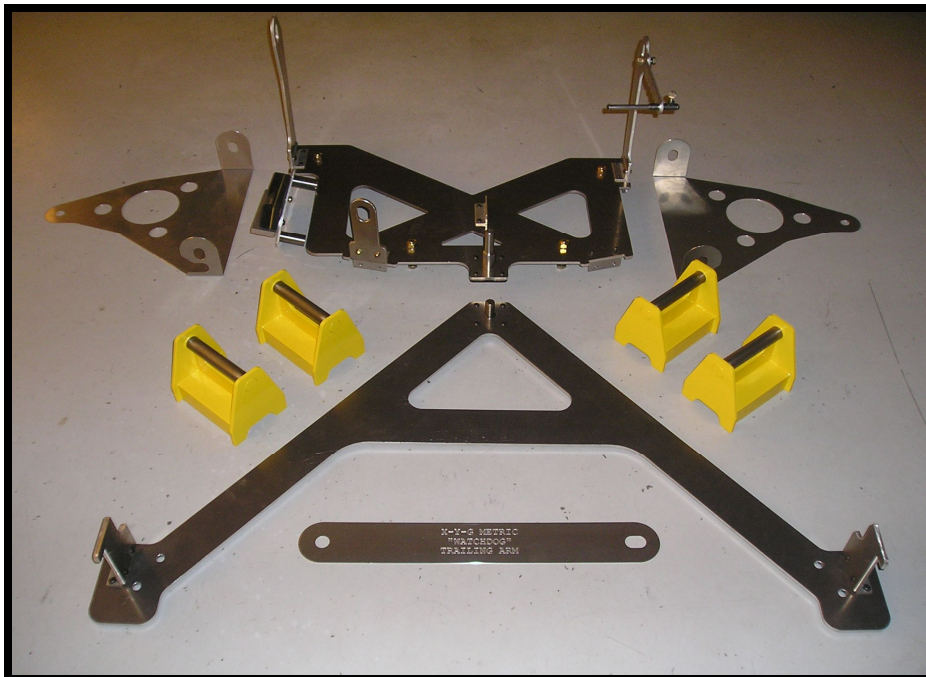

“WATCHDOG INSPECTION SYSTEM”

ALL INSPECTION DONE ON 5 INCH HEIGHT BLOCKS
WITH ALL SUSPENSION ON IN UNDER 10 MIN
FRONT AND REAR SUSPENSION



JACKBOLT CAR WITH OEM FENDER CAR ROLLCAGE AND AFTERMARKET UPPER A-ARMS, AVAILABLE WITH OEM SPRING BUCKET, A-ARM, SHOCK, SWAYBAR, AND ENGINE LOCATIONS.

- ALSO AVAILABLE IN SPORT-MODIFIED & IMCA CONFIGURATION.
- WILL ACCEPT ANY ROLLCAGE A 78-89 G-M METRIC FRAME WILL
- FRAME IS STOCK IN ALL WEIGHTS AND DIMENSIONS
- BOLT JUNK YARD PARTS RIGHT ON

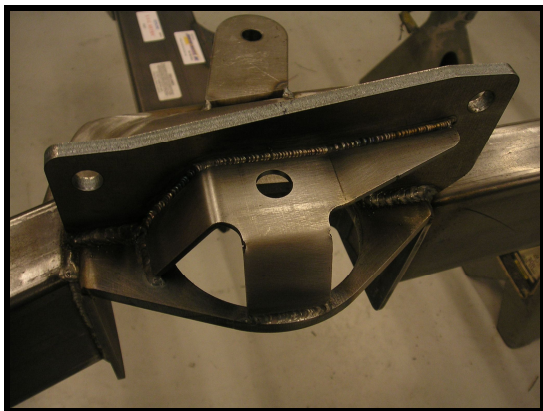

OEM A-ARM & SHOCK MOUNT



OEM 4-LINK CROSSMEMBER



OEM WEIGHT AND DIMENSIONS



INSPECT A-ARMS ON THE CAR NO-GO



OEM WEIGHT 4.5lbs AND DIMENSIONS 19 1/4"
RUBBER BUSHING OR MONOBALL



**UPPER AND LOWER TRAILING ARM INSPECTORS
INSPECT ARMS ON CAR ANYTIME**

VIEW CATALOG
WWW.JOHNSONCHASSIS.COM