

Features

- Pumps abrasive slurries, corrosive material, solids and gaseous liquids with ease
- Ideal for high viscosity or shear sensitive products
- Pumps can run-dry indefinitely without damage
- No check valves or seal water flush systems
- Fully reversible – pumps in either direction
- Minimal maintenance – the hose is the only wearing part
- Pump casings available in a choice of materials including stainless steel
- Suction lift capability up to 9.5 metres and self-priming
- Highly accurate

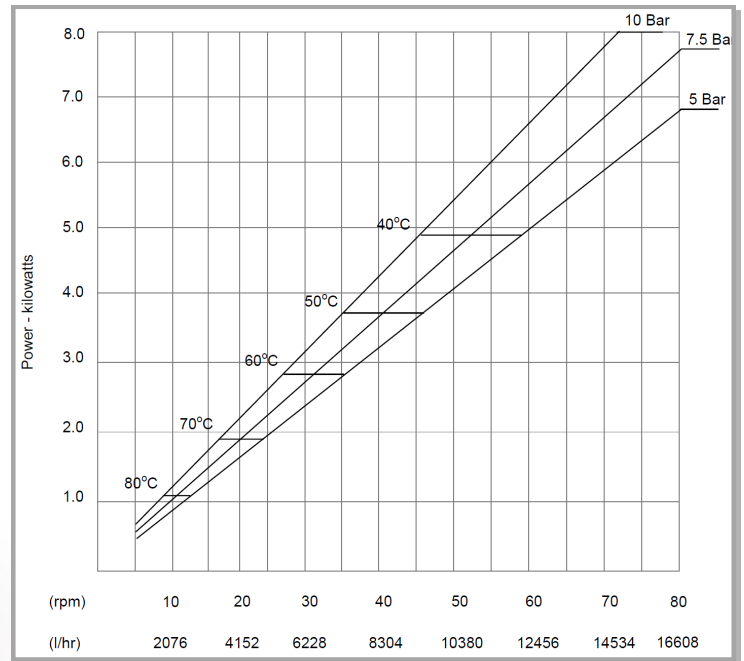

Technical Specifications

Maximum intermittent flow rate of:	16,608 litres per hour / 73.1 gallons per minute
Maximum continuous flow rate of:	10,380 litres per hour / 45.7 gallons per minute
Flow per revolution of:	3.46 litres / 0.914 gallons
Pressure capability of:	10 Bar / 150 psi
Maximum temperature:	80 Degrees Celsius / 176 Degrees Fahrenheit
Inner hose diameter of:	50 mm / 2 inches

Technical Specifications

Operating Speeds:	0 to 80rpm
Product Temperature Range:	-10 °C to +80 °C / 14 °F to 176 °F
Suction Lift:	9.5 metres / 30 feet lift
Hose Materials:	Natural Rubber, Nitrile (Buna), EPDM and CSM
Connections available:	DIN, ASA, JIS: mild steel galvanised
Hose Lubricant Required:	10 litres / 2.64 gallons
Sound level at 1m:	< 70 dB(A) (pumping water at maximum continuous flow)
Optional Hose Failure Sensor:	Capacitive DC sensor

Materials of Construction

Pump housing:	Carbon steel or stainless steel
Rotor:	Aluminium or carbon steel
Compression rollers:	Acetal or steel
Front cover:	Carbon steel
Support Frame:	Carbon steel
Seals:	Neoprene or Nitrile

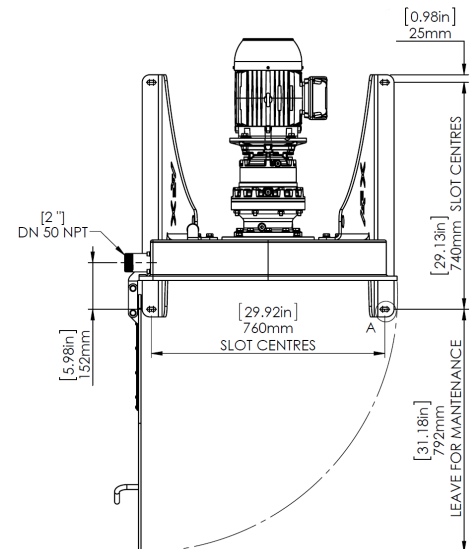
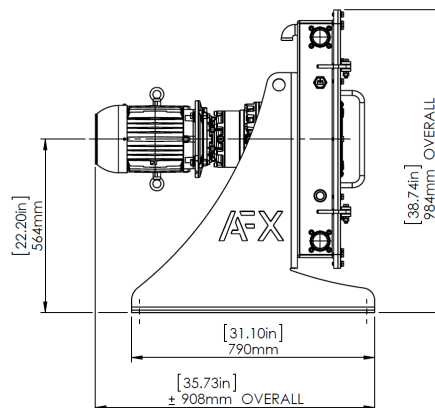
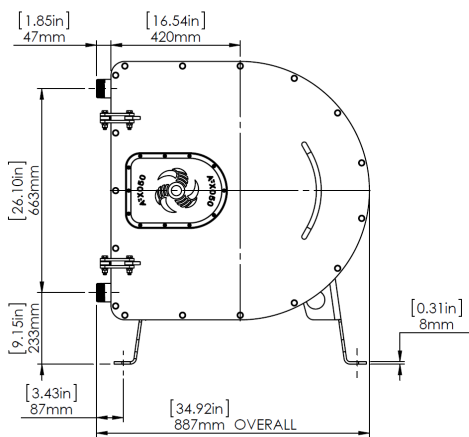

The information contained in this document is believed to be correct at the time of publication, but AFX Mixing and Pumping Technologies Inc. accepts no liability for any error it contains, and reserves the right to alter specifications without prior notice. All values given in this document are values under controlled test conditions. Actual site flow rates achieved may differ due to changes in temperature, product viscosity, suction and discharge pressures and/or system configuration.