

NOTES: UNLESS OTHERWISE SPECIFIED

1. TOLERANCES: +/- .02

MATERIAL: 5052 ALUMINUM ALLOY SHEET 18 GA (.040 THICK)

2. REMOVE BURRS AND BREAK SHARP EDGES

3. SHIPPING PACKAGING SHALL PROTECT PRODUCT FROM SCRATCHES
NO SCRATCHES PERMITTED ON SURFACE INDICATED

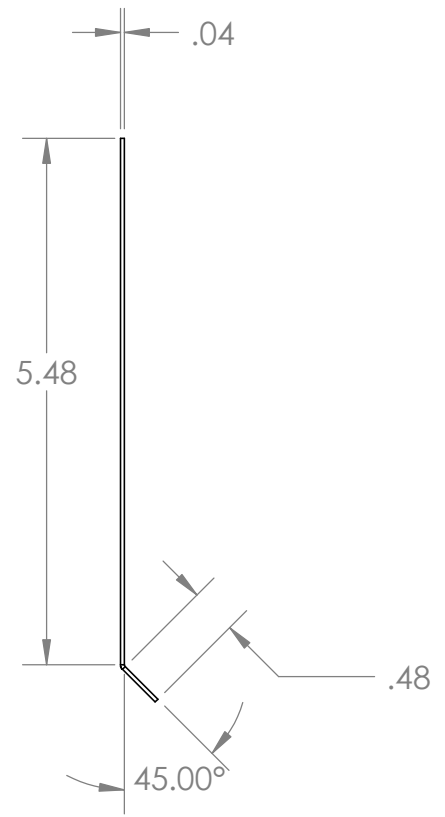
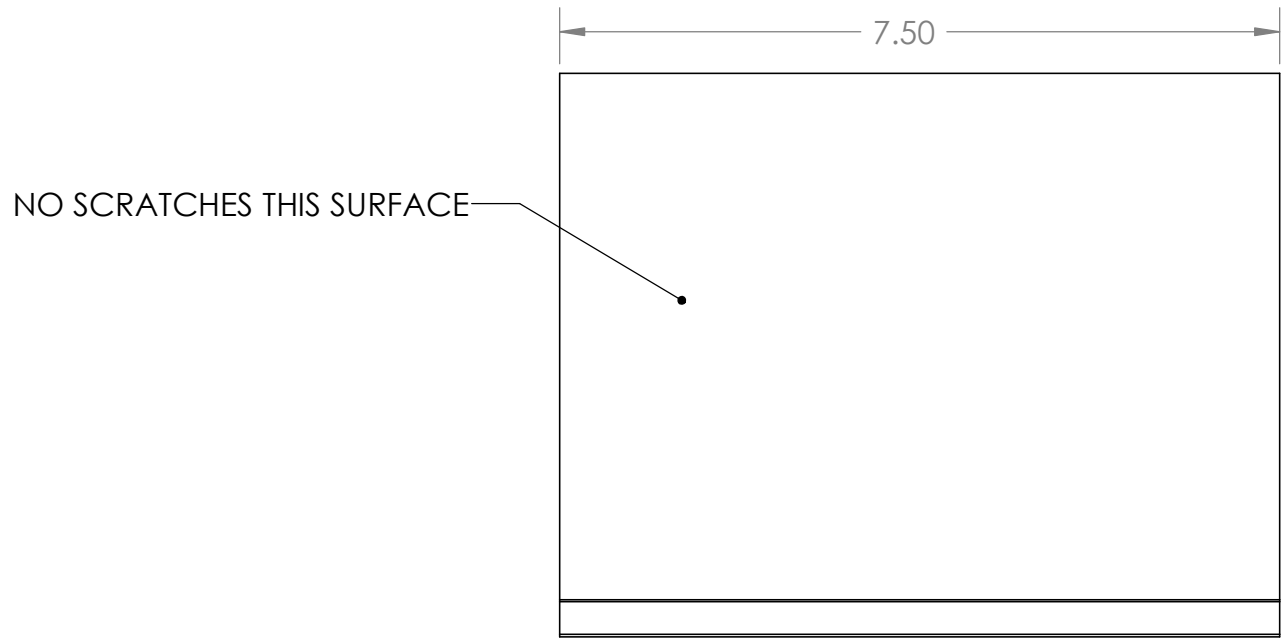

PROPRIETARY AND CONFIDENTIAL

THE INFORMATION CONTAINED IN THIS DRAWING IS THE SOLE PROPERTY OF INSYNC ENGINEERING, LLC. ANY REPRODUCTION IN PART OR AS A WHOLE WITHOUT THE WRITTEN PERMISSION OF INSYNC ENGINEERING, LLC IS PROHIBITED.

INSYNC ENGINEERING
13180 E DESERT VISTA RD
SCOTTSDALE, AZ 82552

COVER, ULTRA

SIZE	DWG. NO.	REV
A	M14010 -001	X2
SCALE: 1:2	WEIGHT:	SHEET 1 OF 1