

METER MAINTENANCE

It is normal for the D625 to accumulate deposits or corrosion after extended use. These deposits adversely influence the natural resonant frequency of the meter and should be removed. The procedure for removing these deposits is fast and easy to perform – and in most cases does not require the meter to be completely removed from the system.

If the meter ever requires a return to the factory for recalibration or repair, the following procedure must be completed prior to shipment to ANALYTICAL FLOW TECHNOLOGIES.

METER CLEANING PROCEDURE

1. Shutdown flow to the D625 Meter – or Shut down pump (if necessary)
2. Close all bypass valves
3. Alleviate any residual pressure in the system

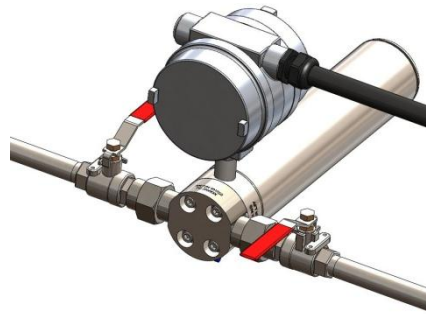

4. Remove the 5/16" -18 x 1 1/4 Socket Head CAP bolts (4) from the density meter
5. Clean the bolts to remove the old anti-seize compound.
6. Clean the flange and inspect the flange face for any debris prior to reassembly
7. Remove the O-Rings
8. Clean the O-Rings and inspect for any damage prior to reassembly

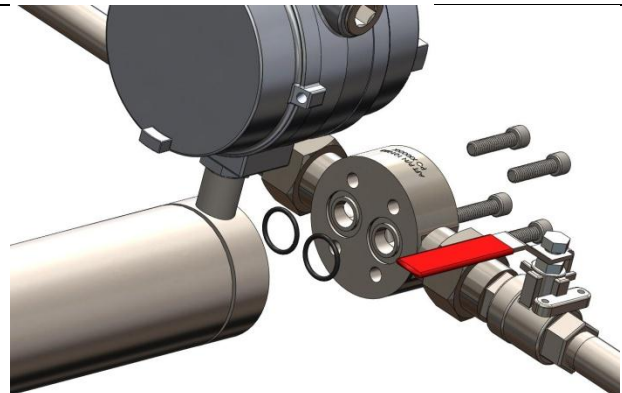

9. Clean the inside of the resonant tubes:
10. Use a 5/8" 3/4" Diameter Bore Brush with a mild cleaner/detergent or Isopropyl alcohol
11. Gently brush the interior of each tube with a back and forth motion
12. DO NOT DAMAGE the resonant tube by inserting hard metallic objects inside the resonant tubes
13. Thoroughly rinse the resonant tube interiors with clean water
14. Repeat Process until rinse water is clear

