

Automated 3D pipe cutting & welding

Forward-looking solutions for
production and processes



The company

Innovative technologies, intelligent software, robust construction and modern design are the four cornerstones of our machine manufacture activities – in the USA and Germany.

At our American location in Puyallup near Seattle and our German Opladen and Erkelenz locations, we produce 3D profile cutting machines for round pipes, tanks, dished-ends, square & rectangular pipes and steel beams as well as automated welding solutions for the toughest requirements in the metalworking industry. The machines and our software solutions are used in all segments of thermal cutting and welding and represent the first and the most important stage of a modern production process.

The high quality of workmanship and the many years of experience of our staff are an assurance of integrated solutions for complex cutting and welding tasks – worldwide.

■ History

Watts Mueller is a US company that was founded by Don Watts as Watts Specialties in the early 1980s. It focused in its early years on the production of small pipe-cutting machines for welding schools. Müller Opladen is a tradition-steeped German engineering company that can look back on an almost century-long history since its founding in 1919.

Müller Opladen became a shareholder of Watts Mueller in 2016.

■ Philosophy

Our philosophy is based on an understanding of our customers' needs and solutions geared to these requirements. This also entails serving our customers in a spirit of partnership throughout the life-cycle of our machines.

■ Research and development

In collaboration with our customers, our engineers in Germany and in the United States are constantly developing new solutions. Thanks to our extensive experience in the fields of CAD, software programming, developing electronic control systems, isometric projection and application-oriented cutting and welding processes, we can ensure that our technologies are always state-of-the-art.

■ Service

The over 1,000 machines at work each day in 72 countries demonstrate the reliability of our products. Our service centers in Germany, USA, Russia, the United Arab Emirates, India, Singapore and Brazil ensure direct communication and machine availability.



Assembly in Puyallup



Assembly in Opladen

■ 3D profile cutting machines

Since the construction of the first mechanical oxy-fuel pipe profile cutting machine with 3 axes in the early 1950s, it has since undergone consistent further development. Today, our machines equipped with up to 9 axes are capable of profiling round pipes, tanks and dished ends as well as square & rectangular pipes and beams. The machines of the current generation are equipped today above all with plasma cutting technology and efficient materials handling systems (logistics). Our software solutions for process planning and control relating to the cutting of various components and for data interchange between the machine and the CAD/CAM systems optimize the production process on the customer site on the principle of Industry 4.0.



Torch head of a pipe profile cutting machine

■ Automated welding solutions

Since taking over the ARC KON engineering firm specializing in automated welding systems in 2003, we have steadily expanded our automated welding business unit. Along with such standard products as positioners, roller beds and columns & booms, we can now also offer customized solutions. These customized solutions support the welding process by automating and coordinating the movements of the workpiece and welding head. The effectiveness, robustness and easy handling of our products ensure high-quality and efficient production.



Automated welding head

Core sectors

You will find us wherever pipes, tanks, beams and other components for the metalworking industry have to be thermally three-dimensionally cut or welded. Owing to our leading position in the 3D pipe profiling machine segment, we serve customers on all five continents mainly in the following sectors:

- Offshore plant construction
- Wind turbine construction
- Steel construction
- Pipeline and process plant engineering
- Pressure vessel construction
- Shipbuilding

Listed below are some of our more than 1,000 reference customers in 72 countries.



Offshore plant construction: platform



Offshore plant construction: top side



Wind turbine construction

Selected reference customers

Selected reference customers	Country
Aker Solutions	Norway
Bosnor	Mexico
Kencana Petroleum	Malaysia
Larsen & Toubro	India, Oman, Qatar, Saudi Arabia, UAE
PTSC	Vietnam
Saipem	Brazil, Canada, Congo, Italy, Nigeria
Sonamet	Angola, Nigeria
Techint	Brazil
Agility Group	Norway
Bosshelf	Azerbaijan
COOEC	China
CUEL	Thailand
Dragados	Mexico, Spain
Keppel Fels	Singapore
Lamprell	UAE
PPL	Singapore
Bilfinger Mars Offshore	Poland
Cimtas	Turkey
Dragados	Spain
Navacel	Spain
ST3	Poland
Steel Engineering	United Kingdom
Tata Steel	United Kingdom
Vitkovice Power Engineering	Czech Republic



Steel construction



Pipeline and process plant engineering



Pressure vessel construction



Shipbuilding

Selected reference customers	Country
Afcons	India
Cimolai	Italy, Venezuela
Cimtas Celik	Turkey
Eiffage Metal	France
Kurganstalmost	Russia
Stahlrohr	Germany
Unger Steel	Austria, UAE
Zamil Steel	Saudi Arabia

Alstom	Germany
Cairn	India
CB&I	USA
Energy Weldfab	USA
Gazgep	Hungary
GEA	Germany, USA
Ponticelli	France, Nigeria
Tranter	China, Germany, USA

Brask	USA
Chart Energy	USA
Everest	Germany
Energy Weld Fab	USA
North Shore	USA
Nouvo Pignone	Italy
Suncore	Canada
Vilmar	Rumania

Cochin Shipyard	India
GSI	China
HDW	Germany
IHC Merwede	Netherlands
Nakilat	Qatar
Navantia	Spain
Samsung	South Korea
Thoma-Sea	USA

3D profile cutting machines

Our thermal 3D profile cutting machines are available in the Watts, MO Classic, MO Heavy-Duty and MO Robo series. The machines of the MO Compact, MO Watts, MO Classic and MO Heavy-Duty series intended essentially for round pipes operate with macro-controlled or freely programmable software, so the machines can be programmed with already available cutting macros or with the aid of our CAD/CAM systems.

The machines of the MO Robo series designed mainly for beams have a freely programmable software architecture that facilitates the autonomous generation of the cutting profiles offline with the use of CAD/CAM modules.

Plasma and oxy-fuel are available as cutting processes. The main differences between the various series can be seen from the table on the following pages.

The CNC-axes of a pipe profile cutting machine can be as follows:

1. Rotation of the workpiece inside the chuck system (Y-axis)
2. Longitudinal movement of the cutting head along the workpiece axis (X-axis)
3. Oscillatory movement of the cutting head (B-axis)
4. Rotation of the cutting head (C-axis)
5. Height adjustment of the cutting head by a measuring system in the event of surface deviations of the workpiece (Z-axis)
6. Torch distance correction in relation to the cutting angle during the cutting process (W-axis)*
7. Transverse movement of the cutting head at 90° to the workpiece axis (V-axis)**

* Available for the MO Compact, MO Classic and MO Heavy-Duty series

** Available for the MO Classic series

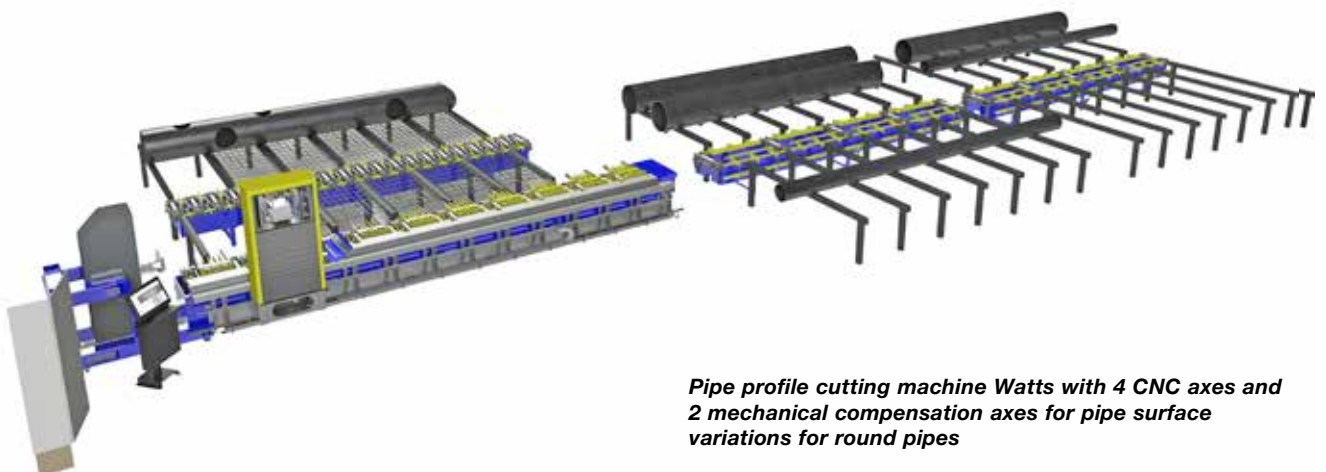

Pipe profile cutting machine Watts with 4 CNC axes and 2 mechanical compensation axes for pipe surface variations for round pipes

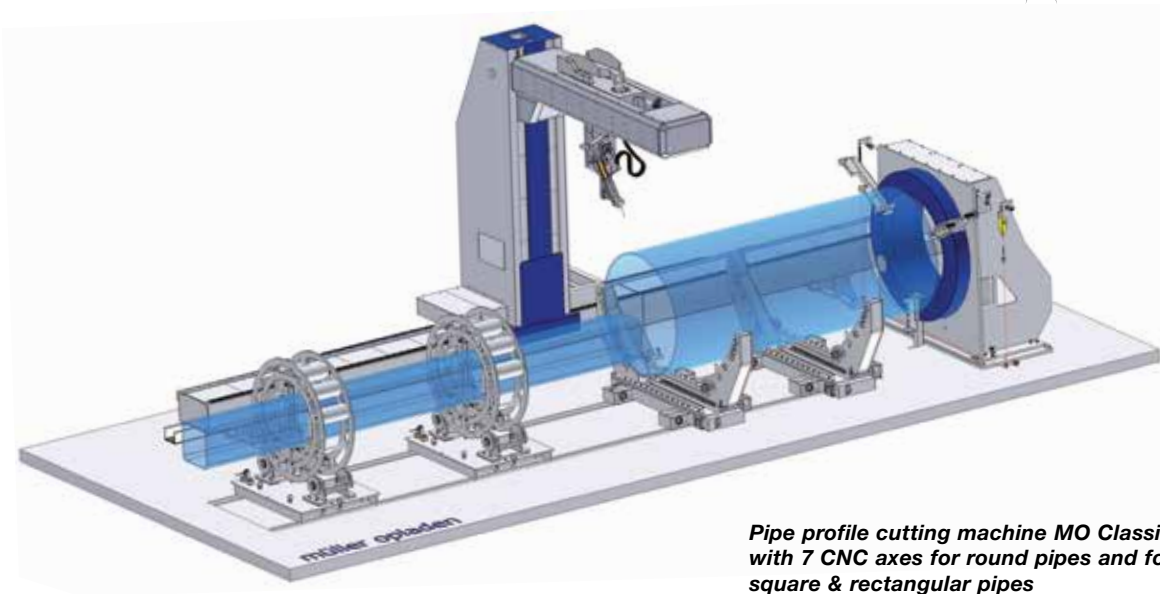

Pipe profile cutting machine MO Classic with 7 CNC axes for round pipes and for square & rectangular pipes

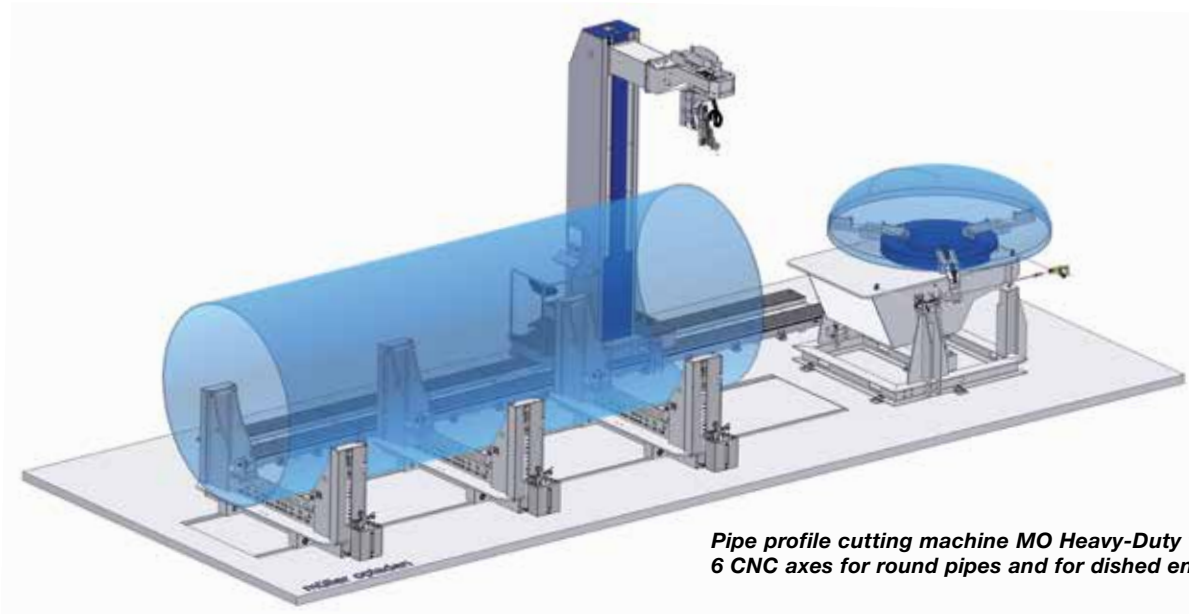

Pipe profile cutting machine MO Heavy-Duty with 6 CNC axes for round pipes and for dished ends

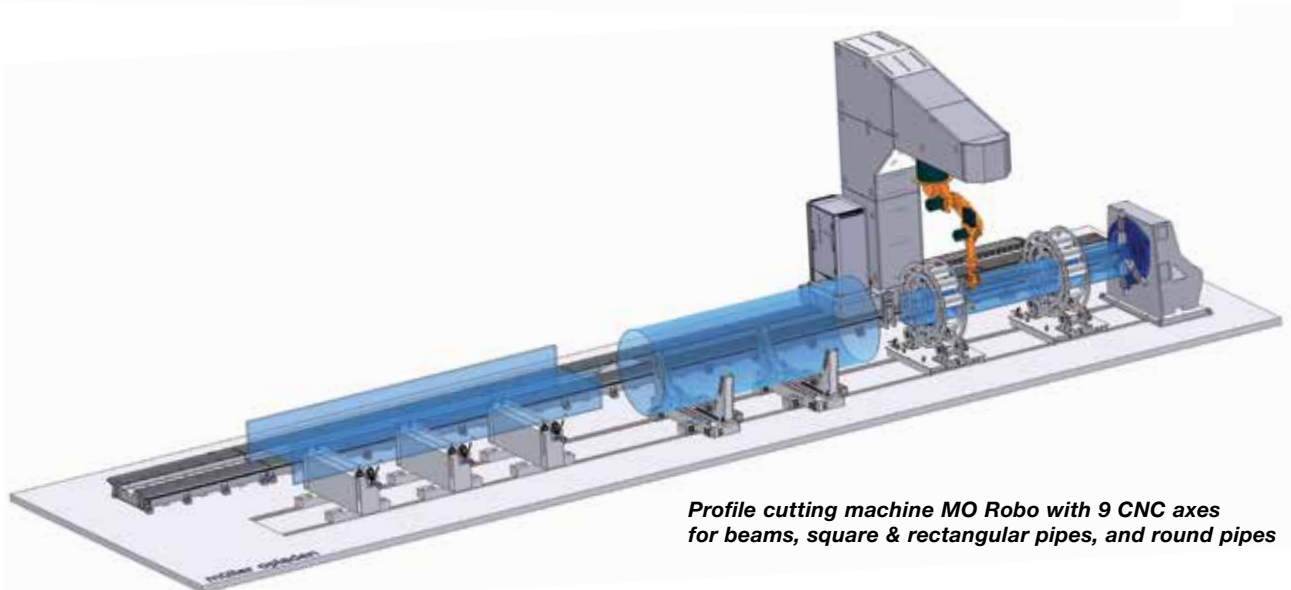

Profile cutting machine MO Robo with 9 CNC axes for beams, square & rectangular pipes, and round pipes

Comparison of the main technical data of the Watts, MO Classic, MO Heavy-Duty and MO Robo series

Technical data:	Watts
Application fields:	Industry
Transportability:	Stationary
Maximum pipe length in feet:	40
Maximum pipe weight in lbs:	26,400
Minimum cuttable pipe diameter in inch:	2
Maximum cuttable pipe diameter in inch:	48
Maximum load of pipe carriage in lbs:	-
Round pipe cuttability:	x
Cuttability of cones:	-
Square & rectangular pipe cuttability:	-
Beam cuttability:	-
Dished end cuttability:	-
Cutting area behind chuck:	-
Automatic workpiece logistics:	x
Maximum number of CNC axes:	4+2
Drive design of CNC axes:	Standard
Pipe tracing:	Electromechanical
Torch carriage track construction:	Frame construction
Mobile operator's platform:	-
Height-adjustable operator's platform:	-
Torch guidance system:	Parallelogram torch head
Oxy-fuel cutting:	x
Maximum cuttable wall thickness, oxy-fuel, in inch:	3.5
Maximum torch tilt angle, oxy-fuel, in °:	60
Omniflow automatic gas control system:	-
Plasma cutting:	x
High-definition plasma cutting:	x
Minimum cuttable wall thickness, plasma, in inch:	0.1
Maximum cuttable wall thickness, plasma, in inch:	3.15
Maximum torch tilt angle, plasma, in °:	45
Machine/plasma system communication interface :	x
Cutting angle correction:	-
Start-position optimization:	-
Joint compensation:	x
Automatic piercing and piercing optimization:	-
Library of standard cutting macros:	x
Library of special cutting macros:	x
Freely programmable software architecture:	-
Work scheduling software:	x
Nesting software:	x
CAD/CAM software:	x
Plasma marking system:	x
Airscriber lettering and/or marking system:	-
Inkjet lettering and/or marking system:	-
Label printing system:	x

* Applicable to machines with a pipe diameter of up to 48 inches

** Only applicable to machines with a pipe diameter of up to 80 inches

MO Classic	MO Heavy-Duty	MO Robo
Industry	Industry	Industry
Stationary	Stationary	Stationary
80	80	40
44,000	88,000	26,400
2*/3.15	7.8	2/3.15
80	160	48
16,500	33,000	16,500
x	x	x
x	x	-
x	-	x
-	-	x
x	x	-
x	x	x
x	x**	x
7	6	9
High dynamics	High dynamics	High dynamics
Electromechanical, laser	Electromechanical, laser	Electromechanical
Column or floor construction	Floor construction	Floor construction
x	x	-
-	x	-
MP torch head	MP torch head	Robot torch head
x	x	x
5.9	7.1	4.7
70	70	70
x	x	x
x	x	x
x	x	x
0.04	0.04	0.04
3.15	3.15	3.15
45	45	45
x	x	x
x	x	-
x	x	-
x	x	-
x	x	-
x	x	-
x	x	-
x	x	x
x	x	-
x	x	x
x	x	x
x	x	x
x	x	x
x	x	-

3D profile cutting machines Watts series

The Watts series comprises standardized machines with sophisticated logistics for round pipes up to a diameter of 48 inches and up to a pipe weight of 26,400 lbs. The machines are all equipped with 4 CNC-controlled axes and 2 mechanical compensation axes for pipe surface variations.

Furthermore the machines can be supplied with only 2 CNC axes as well. However, due to the 2 missing axes, these cheaper solutions generate the cutting shape but without constant weld bevel preparation. The machines are generally fabricated with comprehensive logistics solutions and a floating chuck. All machines of the MO Compact, MO Classic and MO Heavy-Duty series (applicable to machines with a pipe diameter of up to 80 inches) can be also equipped with the logistics solutions of the Watts series.

Detailed information can be supplied on request.



Watts W-122

with 2 CNC axes for round pipes with a maximum diameter of 16 inches inclusive of the Hypertherm MaxPro 200 plasma cutting system, floating chuck and manual adjustable pipe support units



Watts W-244

with 4 CNC axes for round pipes with a maximum diameter of 24 inches compatible with most plasma cutting systems, floating chuck and semiautomatic conveyor system

Watts W-364

with 4 CNC axes for round pipes with a maximum diameter of 36 inches compatible with most plasma cutting systems, floating chuck and full automatic conveyor system with discharge solution for the pipe store



Watts W-484

with 4 CNC axes for round pipes with a maximum diameter of 48 inches compatible with most plasma cutting systems, floating chuck and full automatic conveyor system with discharge solution for the pipe store

The productivity of our machines is boosted considerably by automated workpiece handling with logistics integrated in the machine concept. The picture below shows a typical materials flow for round pipes with a loading and off-loading table. The pipe is transferred from the loading table onto an infeed conveyor. From here the pipe is conveyed to the chuck, where it is clamped and cut. The finished part is then discharged onto the off-loading table in front of the machine, where it awaits further process.



Watts W-244
with in-feed loading table and offload table
for finished parts

Watts W-80
with logistics and automatic material staging



Pipe carriages

In addition to the integrated logistics solutions, the machines can also be supplied with conventional pipe support carriages or with manual or motorized ball gutters

Technical information / Machine series:	Watts W-124 W-122	Watts W-244 w-242	Watts W-364 W-362	Watts W-484 -
Weight of standard machine in lbs:	22,000	24,200	28,600	33,000
Number of CNC axes:	4+2 / 2	4+2 / 2	4+2 / 2	4+2 / 2
Max. workpiece weight in lbs:	11,000	22,000	26,400	26,400
Min. - max. clampable pipe diameter in inch:	2 - 16	2 - 26	2 - 36	2 - 48
Max. size of chuck opening in inch:	-	-	-	-
Min. - max. clampable square & rectangular pipe dimensions in inch:	-	-	-	-
Min. - max. clampable beam width in inch:	-	-	-	-
Min. - max. clampable diameter for dished ends in inch:	-	-	-	-
Min. - max. cuttable workpiece length in feet: *	1** - 40	1** - 40	1** - 40	1** - 40
Min. - max. wall thickness for cutting with oxy-fuel / plasma in inch: *	0.2-3.5 0.1-3.15	0.2-3.5 0.1-3.15	0.2-3.5 0.1-3.15	0.2-3.5 0.1-3.15
Max. torch angle with oxy-fuel / plasma in °:	+/- 60 / 45	+/- 60 / 45	+/- 60 / 45	+/- 60 / 45

* With torch in vertical position

** With additional clamping device up to 2 inches (depending on pipe parameters)

*** Up to 55° when special plasma cutting sources are used



3D profile cutting machines MO Classic series

The MO Classic series covers our classical machines primarily for round pipes with a maximum diameter of up to 80 inches and up to a pipe weight of 44,000 lbs. It is also suitable for square & rectangular pipes and dished ends. The maximum dimensions can be seen in the table of technical data.

Thanks to numerous technical optional extras, these technologically complex machines can be individually adapted to customers' specific needs. The various machines of the MO Classic series can be equipped with up to 7 CNC axes. The 7th CNC axis is necessary for cutting square & rectangular pipes.

Detailed information can be supplied on request.

MO 400/600/6 Classic

with 6 CNC axes for round pipes with a maximum diameter of 26 inches inclusive of the Kjellberg HiFocus 360i plasma cutting system, oxy-fuel cutting system, stationary multi-point extraction system, height-adjustable chuck and fixed-height pipe carriage



MO 650/1200/7 Classic RV

with 7 CNC axes for round pipes with a maximum diameter of 48 inches and square & rectangular pipes of 16.5 inches x 16.5 inches maximum inclusive of the Kjellberg HiFocus 360i plasma cutting system, oxy-fuel cutting system, height-adjustable chuck and fixed-height pipe carriages

MO 950/1500/6 Classic

with 6 CNC axes for round pipes and dished ends with a maximum diameter of 60 inches inclusive of Hypertherm HPR 400XD plasma cutting system, oxy-fuel cutting system, stationary multi-point fume extractor, 7-nozzle inkjet lettering and marking system, and adjustable scissor-type pipe carriages



Technical information / Machine series:	MO 400/600/6 Classic	MO 650/1200/6 Classic	MO 950/1500/6 Classic	MO 950/2000/6 Classic
Weight of standard machine in lbs:	15,400	19,800	24,200	28,600
Number of CNC axes:	6-7	6-7	6-7	6-7
Max. workpiece (round pipe) weight in lbs:	26,400	26,400	33,000	44,000
Min. - max. clampable pipe diameter in inch:	2 - 16	2 - 48	3.15 - 60	3.15 - 80
Max. size of chuck opening in inch:	16	26	36	36
Min. - max. clampable square & rectangular pipe dimensions in inch:	3.9 x 3.9 9.4 x 9.4	3.9 x 3.9 16.5 x 16.5	3.9 x 3.9 24.7 x 24.7	3.9 x 3.9 24.7 x 24.7
Min. - max. clampable beam width in inch:	-	-	-	-
Min. - max. clampable diameter for dished ends in inch:	16 - 26	16 - 48	16 - 60	16 - 80
Min. - max. cuttable workpiece length in feet: *	1** - 80	1** - 80	1** - 80	1** - 80
Min. - max. wall thickness for cut- ting with oxy-fuel / plasma in inch:*	0.02-5.9 0.04-3.15	0.02-5.9 0.04-3.15	0.02-5.9 0.04-3.15	0.02-5.9 0.04-3.15
Max. torch angle with oxy-fuel / plasma in °: ***	+/- 70 / 45	+/- 70 / 45	+/- 70 / 45	+/- 70 / 45

* With torch in vertical position

** With additional clamping device up to 2 inches (depending on pipe parameters)

*** Up to 55° when special plasma cutting sources are used



3D profile cutting machines Heavy-Duty series

Our Heavy-Duty series comprises machines for round pipes and/or dished ends with a maximum diameter of up to 160 inches and up to a pipe weight of 88,000 lbs. The technology is based on that of the MO Classic series. Owing to the large workpiece dimensions and weights, the machines of this series have an extremely solid design. The machines are all equipped with 6 CNC-controlled axes.

Detailed information can be supplied on request.



MO 1200/2500/6 Heavy-Duty

with 6 CNC axes for round pipes with a maximum diameter of 100 inches inclusive of oxy-fuel cutting system, fixed chuck and height adjustable, hydraulic pipe carriages



MO 1500/4000/6 Heavy-Duty RK

with 6 CNC axes for round pipes and dished ends with a maximum diameter of 160 inches inclusive of Hypertherm HPR 400 plasma cutting system, oxy-fuel cutting system, height-adjustable operator stand, tilting chuck and hydraulic scissor-type pipe carriages



Technical information / Machine series:	MO 950/2000/6 Heavy-Duty	MO 1200/2500/6 Heavy-Duty	MO 1200/3000/6 Heavy-Duty	MO 1500/4000/6 Heavy-Duty
Weight of standard machine in lbs:	39,600	48,400	52,800	61,600
Number of CNC axes:	6	6	6	6
Max. workpiece (pipe) weight in lbs:	88,000	88,000	88,000	88,000
Min. - max. clampable pipe diameter in inch:	7.8 - 80	7.8 - 100	7.8 - 120	7.8 - 160
Max. size of chuck opening in inch:	36	48	48	60
Min. - max. clampable square & rectangular pipe dimensions in inch:	-	-	-	-
Min. - max. clampable beam width in inch:	-	-	-	-
Min. - max. clampable diameter for dished ends in inch:	16 - 80	16 - 100	16 - 120	16 - 160
Min. - max. cuttable workpiece length in feet: *	1 - 80	1 - 80	1 - 80	1 - 80
Min. - max. wall thickness for cutting with oxy-fuel / plasma in inch:*	0.2-7.1 0.04-3.15	0.2-7.1 0.04-3.15	0.2-7.1 0.04-3.15	0.2-7.1 0.04-3.15
Max. torch angle with oxy-fuel / plasma in °:	+/- 70 / 45	+/- 70 / 45	+/- 70 / 45	+/- 70 / 45

* With torch in vertical position



3D profile cutting machines MO Robo series

The MO Robo series covers robot-controlled machines that are mainly intended for the comprehensive cutting of beams (H, U, L and I). They are also capable of cutting round pipes and square & rectangular pipes. Beams can be cut up to a web width of 48 inches and up to a weight of 26,400 lbs. The maximum dimensions can be seen in the table of technical data.

If the various workpieces – beams, square & rectangular pipes or round pipes – are to be profiled, the machines are equipped with 9 CNC-controlled axes. The workpieces are loaded onto the beam cutting bed by a crane. Alternatively, we can also supply the machine exclusively for beams with a cutting cell and automated infeed and outfeed.

Detailed information can be supplied on request.

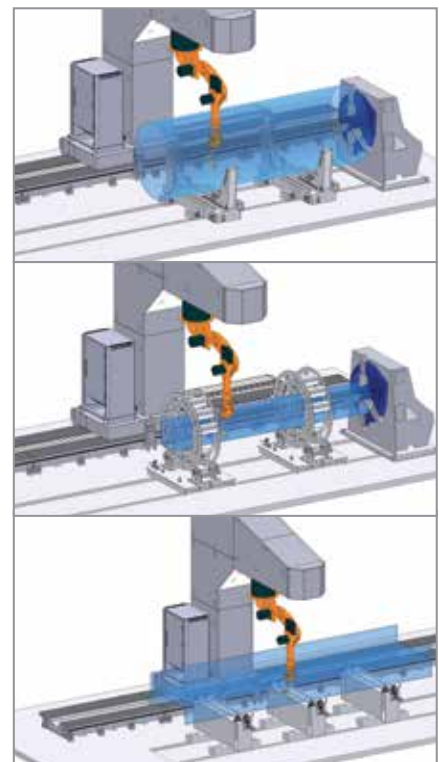

MO Robo 1200/9 TR

with 9 CNC axes for beams with a maximum width of 48 inches and round pipes with a maximum diameter of 48 inches inclusive of oxy-fuel cutting system, fixed chuck, beam cutting bed and height-adjustable, scissor-type pipe carriages

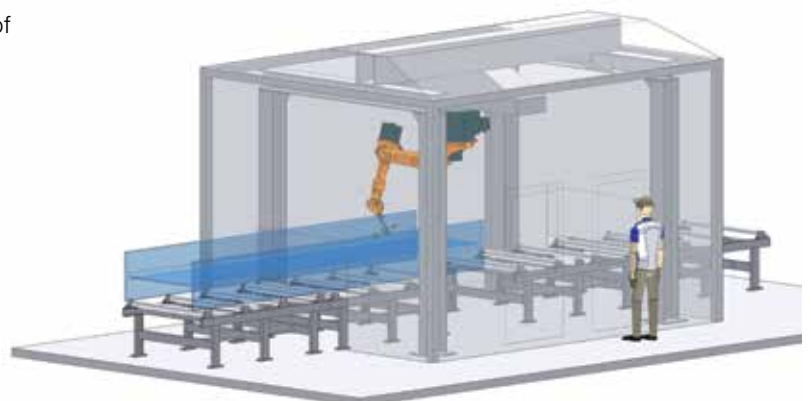

Technical information / Machine series:	MO 200 Robo	MO 600 Robo	MO 800 Robo	MO 1200 Robo
Weight of standard machine in lbs:	15,400	26,400	28,600	35,200
Number of CNC axes:	7-9	7-9	7-9	7-9
Max. workpiece weight in lbs:	8,800	17,600	26,400	26,400
Min. - max. clampable pipe diameter in inch:	2 - 16	2 - 26	2 - 32	2 - 48
Max. size of chuck opening in inch:	16	16	16	26
Min. - max. clampable square & rectangular pipe dimensions in inch:	3.9 x 3.9 9.4 x 9.4	3.9 x 3.9 9.4 x 9.4	3.9 x 3.9 9.4 x 9.4	3.9 x 3.9 16.5 x 16.5
Min. - max. clampable beam width in inch:	2 - 8	2 - 24	2 - 32	2 - 48
Min. - max. clampable diameter for dished ends in inch:	-	-	-	-
Min. - max. cuttable workpiece length in feet: *	1 - 40	1 - 40	1 - 40	1 - 40
Min. - max. wall thickness for cutting with oxy-fuel / plasma in inch:*	0.2-4.7 0.04-3.15	0.2-4.7 0.04-3.15	0.2-4.7 0.04-3.15	0.2-4.7 0.04-3.15
Max. torch angle with oxy-fuel / plasma in: °	+/- 70 / 45	+/- 70 / 45	+/- 70 / 45	+/- 70 / 45

* With torch in vertical position



3D profile cutting machines Software

Our software solutions for machines and processes make our customers' production workflows more efficient. Our machines for the thermal cutting of 3D contours are not therefore isolated elements, but part of an integrated process chain.

With our CAM modules, we are able to link our machines to upstream and downstream workflows to significantly reduce production time, material costs and errors.

The software *PypeServer*® is the basis for the Watts, MO Classic and MO Heavy-Duty machine series.

The *AlmaRobo*® software is the basis for the MO Robo series.

■ *PypeServer*® CAD/CAM system for the Watts, MO Classic and MO Heavy-Duty machine series

PypeServer® is a comprehensive CAD/CAM system for the purpose of modeling cutting geometries, for nesting numerous parts to be cut on a single pipe, for assigning cutting functions to one or several machines while taking into account their respective capacity, for keeping track of current working process stages at the machines and for calculating and recording cutting times and costs.

PypeServer® also provides extensive reporting functions for calculation or documentation purposes. Furthermore, *PypeServer*® provides comprehensive reporting for downstream costing and documentation purposes. *PypeServer*® can be fully integrated in a company's workflow as an autonomous software system for the modeling of pipes or by importing drawings from a multitude of CAD software systems.

PypeServer® offers rich data in SQL views that can be pulled into Excel and other tools for reporting, and into ERP systems or other databases. *PypeServer*® is typically run at both the machine and in offices. In offices, CAD designers and detailers import jobs, design parts, and plan work. At the machine, machine operators nest parts on pipes and cut jobs.

■ *PypeServer*® and SQL databases

PypeServer® runs on top of SQL databases. These databases expose a rich set of data views for use in ERP, process management, inventory control, and custom reporting.

Our customers often integrate *PypeServer*® data with their ERP system, and also with Microsoft Excel to create custom live reports for job costing, scheduling and tracking, inventory control, and post-job analyses.

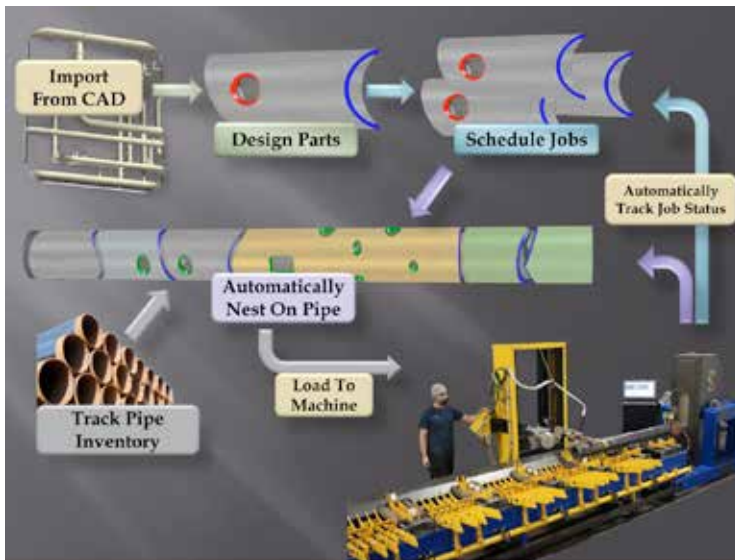

PypeServer® CAD/CAM system

■ **PypeServer® modeling module**

The PypeServer® modeling module permits independent production of pipe cutting contours represented in 3D with dimension contours. To begin with, a cutting contour such as a saddle cut is selected. Then, only a few parameters need be entered into a pre-set mask to allow the cutting contour to develop automatically. Repetitive contours can simply be duplicated.

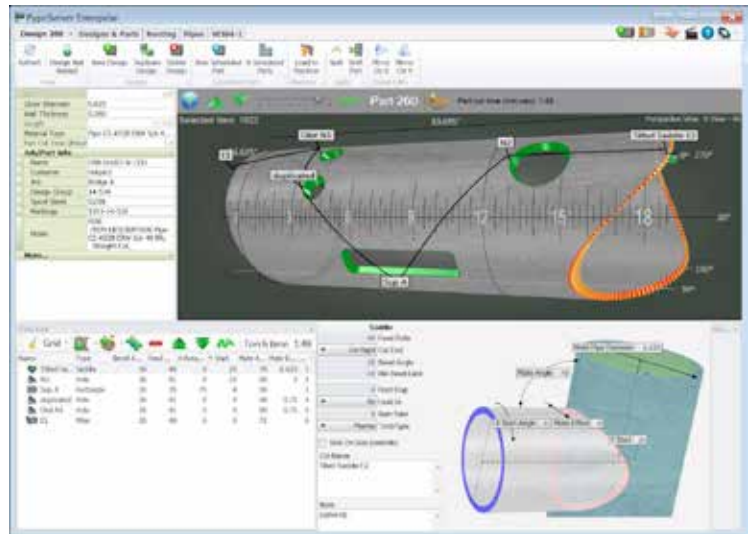

PypeServer® modeling module

■ **PypeServer® CAD import module**

PypeServer® can import parts and complete design spools of most well-known software CAD systems such as Acorn, AutoDesk, Aveva, BoCAD, COMPRESS, Intergraph, Pro CAD, Pro Engineer, Ship Constructor, Solid Works or Tekla Structures. Custom importers for special CAD systems can be developed in cooperation with customers.

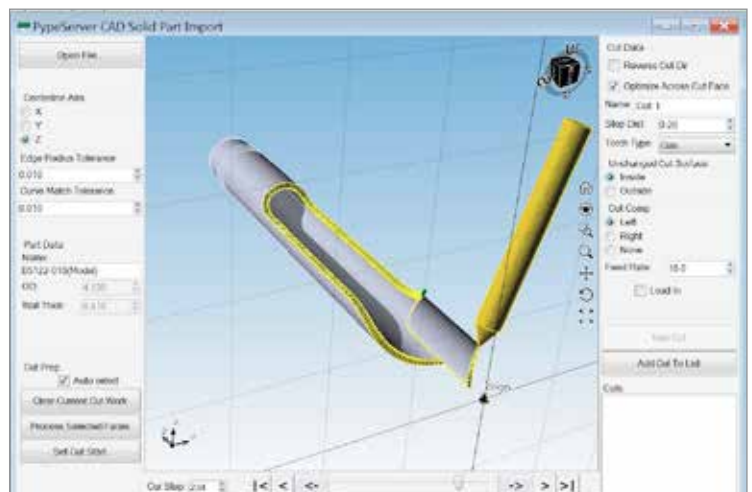

PypeServer® CAD import module

■ **PypeServer® nesting module**

Once all the parts have either been modeled or alternatively imported, PypeServer, with a single command, automatically nests the parts on a pipe. This algorithm for such optimal nesting can save up to 10 percent in materials. The pipe segments to be cut are then shown in 3D on the monitor.

During the cutting process, both the machine operator and those using PypeServer® in offices can remotely see the machines' cutting progress.

PypeServer® integrates also software that can automatically print unique labels for each part.

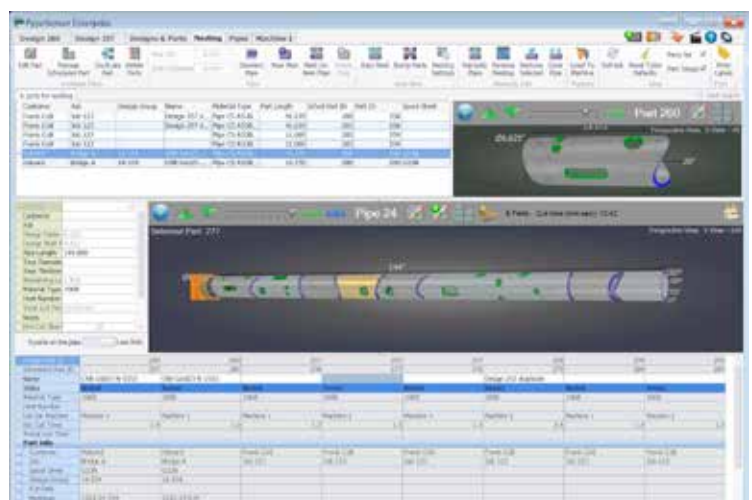

PypeServer® nesting module

Mechanized solutions for cutting (straight cutt-off fixtures)

Simple straight cut-off fixtures designed for a maximum load of 3,300 lbs and for a maximum pipe diameter of 32 inches are used for cutting several pieces out of a pipe, with or without weld bevel preparation. These fixtures are much more economic than sawing.

The standard versions of our straight cut-off fixtures have the following features:

- Drive unit and support unit including a base frame and centrally displaceable roller consoles
- Fastening chain to prevent pipe slippage during the rotation process
- Manually movable cutting carriage with length measuring system, torch fixture and vertical scanning mechanism for retaining the torch height and angle position on curved and non-circular pipes
- Template for torch angle positioning to generate weld bevel preparation
- Standard control
- Oxy-fuel or plasma cutting system



W-132

	Max. load in lbs:	Min. – max. Ø in inch:	Min. – max. length in feet:
W-116	3,300	2 – 16	0.65 – 140
W-132	3,300	2 – 32	0.65 – 140

Table-top cutting fixtures designed for a maximum load of 110 lbs and for a maximum pipe diameter of 12 inches are used for simple cut-offs with weld bevel preparation at short pipes.

The standard versions of our mechanized table-top cutting fixtures have the following features:

- Machine frame in a heavy-duty welded design
- Manuel chuck for clamping short pipes
- Torch fixture with torch angle positioning function
- Standard control
- Oxy-fuel or plasma cutting system
- Optional with cutting template for longitudinal motions along the pipe axes for the cutting of miters and saddle cuts



W-60-20-SM

	Max. load in lbs:	Min. – max. Ø in inch:	Min. – max. length in feet:
W-60-20-SM	110	2 – 12	0.16 – 1

Mechanized solutions for welding (welding positioners)

Welding positioners designed for maximum loads of 110 lbs to 88,000 lbs have universal applications in the manual and mechanical welding of circumferential seams and in the accurate positioning of workpieces.

The standard versions of our positioners have the following features:

- Machine frame in a heavy-duty welded design
- Manual, electric or hydraulic slewing adjustment
- Fully machined turntable plates of various sizes with centering grooves and T-slots from the model MO-DT-500 and higher
- Standard control

Possible optional extras:

- Hollow bores of various diameters
- Circumferential seam welding and process controls
- Extensive system accessories such as three-jaw chucks and positioners

In addition to slewing positioners, we can also supply the following alternative series:

- Horizontal positioners
- Vertical positioners
- Slewing and hydraulically height-adjustable positioners
- Multi-axis positioners

Detailed information can be supplied on request.



MO-DT-1000



MO-DT-15000-HV with hydraulic height adjustment

	Max. load* in lbs:	Shaft Ø in inch:	Slewing range in °:	Speed in RPM:*
MO-DT-30	66	–	+/- 90	0,125 – 5,0
MO-DT-50-HW-30	110	1.2	+/- 90	0.125 – 5.0
MO-DT-100-HW-125	220	4.9	+/- 90	0.125 – 5.0
MO-DT-200-HW-125	440	4.9	+/- 90	0.125 – 5.0
MO-DT-300-HW-125	660	4.9	+/- 90	0.125 – 5.0
MO-DT-500-HW-200	1,100	7.8	+/- 90	0.06 – 2.4
MO-DT-1000	2,200	–	120	0.06 – 2.4
MO-DT-2000	4,400	–	120	0.05 - 1.0
MO-DT-3000	6,600	–	120	0.05 - 1.0
MO-DT-5000	11,000	–	120	0.05 - 1.0
MO-DT-10000	22,000	–	120	0.05 - 1,0
MO-DT-15000	33,000	–	120	0.05 - 1.0
MO-DT-20000	44,000	–	120	0.05 - 1.0
MO-DT-30000	66,000	–	120	0.05 - 1.0
MO-DT-40000	88,000	–	120	0.05 - 1.0

* For centric workpieces



Watts Mueller LLC

2323 East Pioneer Suite. A
Puyallup, WA 98372
USA

Phone: +1 - 253 - 848 - 9288
Fax: +1 - 253 - 848 - 9295
Sales: +1 - 832 - 701 - 7121
Email: mail@watts-mueller.com
Internet: www.watts-mueller.com