

SETTING UP THE COBRA - note the Cobra must be connected to a receiver which is bound to it's transmitter. For power curve setting see overleaf.

Factory default values: Bi-directional operation, Stop position at 1.50ms, Full fwd at 1.95ms, full reverse at 1.05ms, inertia control period 1 second, power curve 2.

Technical note: standard servo protocol is provided by r/c systems based on a pulse variation from 1 to 2 milliseconds, with the centre position therefore being at 1.5ms. In practice, with manufacturing tolerances and with cheaper designs, this can vary significantly, which is why the calibration facility is provided on the Cobra. In some cases, where the signal is a long way outside the specification, the Cobra may not be able to calibrate. If this happens, please contact us for advice.

1. Turn your transmitter, then turn on your loco.
2. The red LED will flash quickly for 2.5 seconds. Press and release set-up button to enter calibration within this period.
3. If there is no button press in this time, the Cobra will start normal operation.
4. If the button has been pressed in this time, the LED will be fully ON.
5. To alter **Inertia**, press and release the SET-UP button.
6. The LED will now flash rapidly, press and hold down the button for the length of time you wish the inertia to act for - up to a maximum of 31 secs. The LED will be fully on in this time. If you do not wish to change the Inertia, just release the button within 1 second. Once the button is released you can power down the Cobra if you do not wish to change any other settings, or proceed to setting the STOP, FULL FWD, FULL REV and MAX SPEED settings.
7. The LED will now flash slowly with equally spaced flashes. Put the stick or knob to STOP (zero power) position and press and release the SET-UP button.
8. The LED will now flash slowly with unequal flashes mostly ON. Put the stick or knob in the direction you wish to be fully FORWARD (full power) and press and release the SET-UP button.
9. The LED will now flash slowly with unequal flashes mostly OFF. Put the stick or knob fully REVERSE (full power) and press and release the SET-UP button.
10. The Cobra can now be adjusted to reduce the Maximum Speed of the model. If this is NOT required, turn off the power and restart as usual. You can now drive the model with the speed control - **WARNING the model will move** - set the speed to the desired maximum and press the set-up button once more, you will notice a decrease in the speed of the model as the range is adjusted. Now power off and restart.

NOTES:

Unidirectional forward operation - if at step 7, the stick or knob is set to the lowest position, and at step 8 and 9 is set to the same maximum position, the Cobra will operate in the Forward direction only, within the set speed range.

Unidirectional reverse operation - if at step 7 and 8, the stick or knob is set to the lowest position, and at step 9 is set to the maximum position, the Cobra will operate in the Reverse direction only, within the set speed range.

Inability to calibrate - if at steps 7 or 8 the normal sequence is not achievable it may be that the radio is providing an inaccurate PWM signal outside the range of the Cobra. Please call us for advice.

COBRA ESC-260

100W High Frequency Speed Controller

WITH POWER PROTECTOR

Made by:



P.O.Box 675
Blackburn,
Lancs. BB1 9DL
UK

WWW.FOSWORKS.CO.UK Tel 01254 814675

SILENT OPERATION - HIGH FREQ.

SMOOTH START

3 SELECTABLE POWER CURVES

ADJUSTABLE INERTIA

COMPACT SIZE

COMPATIBLE WITH ALL BRUSHED DC MOTOR TYPES INCLUDING CORELESS

POWER PROTECTOR IF CONTROL NOT CENTRED ON SWITCH ON.

EMERGENCY STOP FEATURE

DIRECTIONAL LIGHTING OUTPUTS

MAX SPEED ADJUSTMENT

Radio Controlled, High Frequency, Microprocessor Controlled Motor Speed Controller

INPUT 6—28 volts . OUTPUT . 0 - 28 volts up to 14 A Peak
5V BEC provides up to 400mA available on receiver pins

Maximum continuous power 100 Watts Only 60mm x 27mm x 12mm



COBRA Silent control

The Cobra will work with all makes of Radio Control equipment, both FM and AM, 40MHz, 27MHz, but we would recommend 2.4GHz, especially the OMNI system, for reliable operation.

POWER CURVE SETTING

The Cobra has three power curves which can easily be set by the user.

1. Standard straight line response to the regulator.
2. Slow start, and a more rapid rise at higher power up to full power.
3. Straight line up to half power for shunting.

To set the power curve:

1. With everything switched on and settled, with the regulator in the off position, observe the Cobra. It will be flashing in groups of one, two or three flashes.
2. To change the setting, press and hold the set-up button until the LED stays on constantly.
3. Now release the button and the setting will change to the next curve. The Cobra will again flash in groups of 1, 2 or 3 flashes to indicate the new curve selected. For example, if the Cobra was initially on curve 2 and you want to select curve 1, then steps 2 and 3 will have to be repeated twice to get the power curve back onto setting 1.

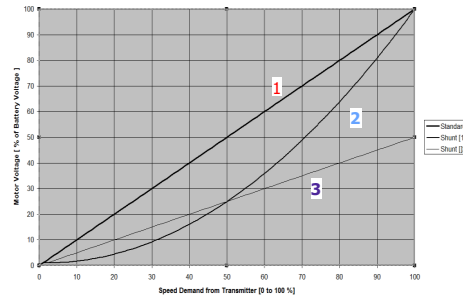

OPERATION

Power up the transmitter, THEN the locomotive. Wait 3 seconds for the controller to settle. The locomotive should respond smoothly to your movement of the regulator control;

POWER PROTECTOR - If you have turned on the handset with the regulator away from the off position, the Cobra will not give you power until you have returned the regulator to off.

REVERSING - when changing direction, you must pause at zero momentarily, otherwise the Cobra will read the action as an emergency stop.

EMERGENCY STOP - move the regulator quickly to the opposite direction and the Cobra will bring the power to zero within 2 seconds, giving a controlled but rapid stop. The regulator must then be returned to zero momentarily to restart.

If you find that the control is too abrupt or too sluggish, then you can adjust the **power curve** on the Cobra as shown above.

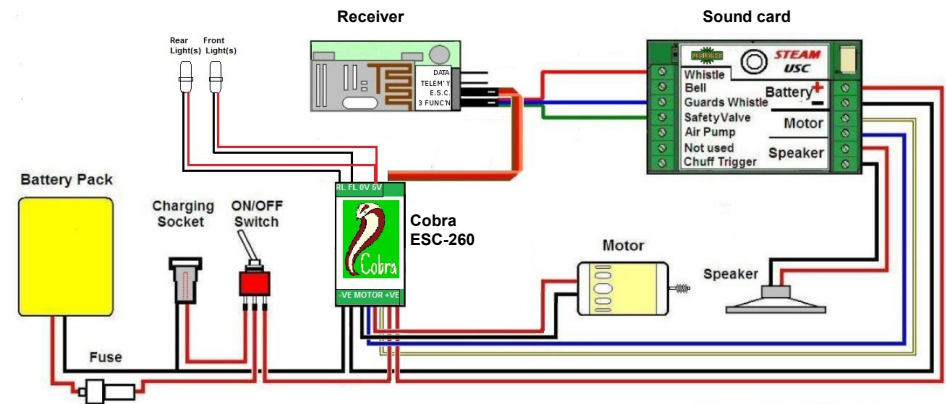

WIRING UP THE LOCO

Above is the full circuit diagram including a sound card, in this case the 100W Cobra provides directional lighting.

Look at the circuit diagram above to wire up your loco. Employ a suitable fuse for protection. For maximum protection use a **3.15A fast blow** fuse for smaller locos - 0 gauge or Gauge 1 tank engines. A **5A fast blow** fuse should be used for larger locos. If this proves to be insufficient, please contact us for advice. The white red and black cable goes to ESC on the receiver. Connect the Cobra servo plug into your receiver the correct way around (black to negative) on the following pins: OMNI-ESC pins, Rx102-Ch.1 pins, Spektrum-ELEV, Planet-ELEV, 27 & 40mHz-Ch.2

The large 4 way terminal block is for connections to the motor (2 centre terminals) and outside terminals for connection to the power supply, polarity is very important on the power input, incorrect connection will blow the fuse and possibly damage the Cobra.

LIGHTING

The lighting connections are shown above using the terminals on the Cobra. This is subject to a total maximum current draw of 2A, due to track size on the Cobra pcb. Note that battery voltage is provided, so LED's must have suitable resistors fitted (Usually 10k Ohm.)

If higher power lighting is required, then supply the positive side of the lighting circuit directly from the battery or via a suitable voltage reduction device. The RL and FL terminals on the Cobra provide a switch to -ve (ground) facility with a maximum current draw of 2A.

Everything shown is available from FOSWORKS. If you buy a complete system from us it will be assembled and tested ready for you to install in your loco.