

# OMNI Tx-3.0 Servo 2.4GHz Handheld Transmitter

You no longer need that big transmitter anymore! The programmable **OMNI Tx-3.0 Servo** handheld transmitter will control your garden railway live steam locomotives perfectly from the palm of your hand. An **Omni Rx-3 or Rx23** receiver will be needed to work with the **OMNI Tx-3.0** transmitter.

**2.4GHz gives perfect glitch free control for up to 800 metres range.**

Four servos can be controlled from an OMNI Tx-3.0 Servo Transmitter. Two infinitely variable and two with stop positions. Cruise control is possible by turning off the transmitter while the train is running. Turn back on to instantly regain control.

## Black Push Buttons 1, 2, and 3

Buttons 1 and 2 control Servo 3. Button 3 controls Servo 4 and BIND

Press 1 and the servo moves to the left. Press again and it returns to centre.

Press button 2 for Right movement and again for centre. Ideal for simple reverser.

Press button 3 and Servo 4 swings from left to right. Release and the arm swings back. Excellent for operating whistles and couplings etc.

Buttons 1,2 and 3 are also employed in re-programming the transmitter

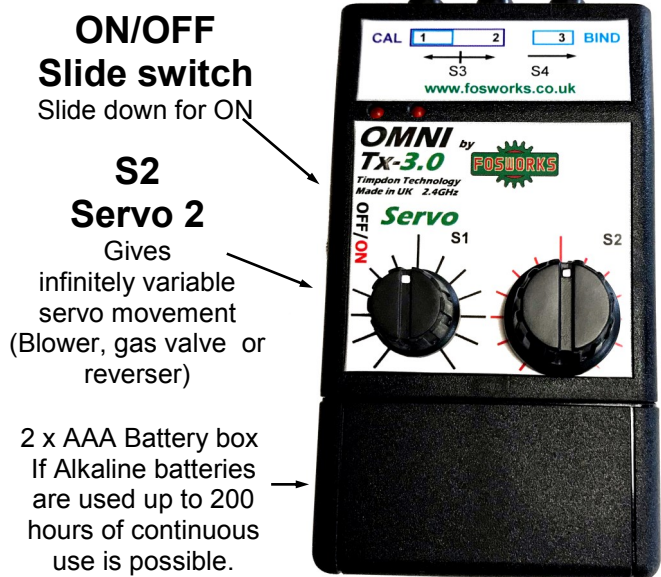

## More Info

For more information see overleaf

### S1 Servo 1

Gives infinitely variable servo movement (Regulator, gas valve, etc.)

**Telemetry** - by default, telemetry (i.e. feedback from the receiver to the handset) is not activated for a longer battery life. If it is required, then it must be activated with the following procedure: Turn Transmitter OFF, Hold down buttons 1,2, and 3. Turn on transmitter and keep holding down all three buttons until LED2 goes on. Release all buttons. It is now active and LED2 will illuminate whenever the telemetry input on the FRx23 is grounded. To de-activate, use the same procedure. If the Rx fails to send to the handset, the LED will begin flashing 2 times per second to indicate loss of feedback so the model should be checked to see if the battery is low or some other fault has occurred.

# OMNI Tx-3.0 Servo Programmable 2.4GHz Transmitter For Live Steam Locos

Another  
**PETER SPOERER**  
PRODUCT MADE BY



P.O. BOX 675,  
Blackburn, Lancs.  
BB1 9DL  
UK

WWW.FOSWORKS.CO.UK  
Tel 0(44)1254 814675



**Programmable Four Servo Operation**  
S1 and S2 infinitely variable. S3 three position, S4 two position  
2.4GHz Technology by Timpdon  
Requires an **OMNI Rx-3 or Rx23** receiver.  
Up to 800 metres range  
Telemetry feedback on LED 2, ideal for monitoring boiler water level.

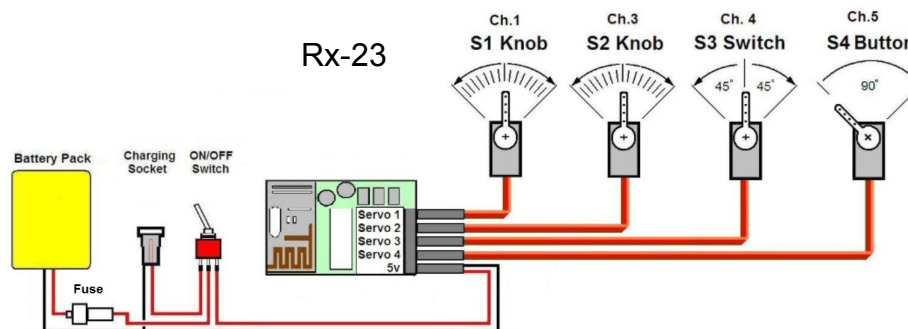

Rx-23 receiver circuit diagram for use with a four Servos.

## Binding Procedure.

Now simpler than ever!

1. Turn on the Receiver (or the model, if it's already fitted inside) then....
2. Hold down black buttons 1 and 3, then turn on the transmitter
3. Successful binding is indicated by LED 2 going ON.
4. Release the two buttons and the job is done. LED 1 goes solid to indicate that the transmitter and receiver are linked.

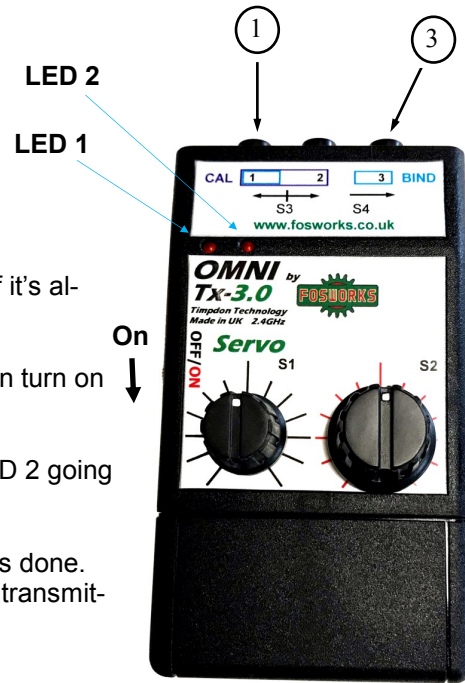

## Calibrating Servo start, mid and end positions.

Each servo can have its start and end settings adjusted independently. The S1 servo knob is used to adjust all four servo settings. The transmitter and receiver must be already bound together and tested. It's on video, if you prefer, see our website for the link.

The Calibration procedure must be carried out within 20 seconds of turning on the receiver, so start by ensuring everything is off, then power up the receiver.

- 1 Press and hold buttons 2 and 3, then turn Transmitter **ON**
- 2 Wait until both LEDs go solid, then release the buttons, you are now in calibration mode and the only exit is to power off the transmitter.
- 3 LED 1 will be flashing the selected SERVO, use Button 1 to move to the next one.
- 4 LED 2 will be indicating which servo position you wish to set, use button 2 to move to the next one:
  - One flash = Start position of servo swing (When knob is fully anticlockwise)
  - Two flash = Mid position of servo swing (Not available on servos 1,2 and 4)
  - Three flash = End position of servo swing (when knob is fully clockwise)
- 5 Having selected the servo and the position you wish to set, use the S1 knob to set the actual position of the servo arm and then save the position by pressing button 3.
- 6 You can now go on to set more positions or leave the process by turning off the transmitter, then back on again to check the results of your efforts.

## Low battery warning

When the batteries in the handset get too low for reliable operation, both LED 1 and 2 start flashing together. Replace them with quality alkaline AAA cells for the best results,

## Re-programming the OMNI system to suit your needs.

Your OMNI transmitter and receiver comes to you all pre-set and ready to run Live Steam Locomotives. Each servo is set for a full 90 degree swing. Normally there should be no need to change these settings, However should the swing of a servo need to be modified, it can be done by reprogramming the receiver.

The OMNI R/C system is unique, in that when you wish to re-program it to suit the special needs for a particular loco, it is not the transmitter you are re-programming, but the receiver in the loco. The Transmitter tells the receiver what is expected of it in the future, and it is the receiver that remembers it. In this way, one OMNI Tx-3.0 STEAM transmitter can control many different types of Live Steam locos, each with its own very different requirements.

It is possible to change all or just one of the servo movements. The start and stop position of each servo swing is adjustable. You can even reverse the servo swings by setting the 1st position as the end and the 2nd position as the start.

## Re-Programming Servo 3 and 4 to momentary or latching mode

**Servo 3**, when set to latching, toggles between mid and end positions on buttons 1 and 2, when set to momentary, will move from mid to start on button 1 and mid to end on button 2, then back to the middle again.

**Servo 4**, when set to latching, toggles position from one end to the other on each press of button 3 and when set to momentary moves from start to end position and back again.

The Calibration procedure must be carried out within 20 seconds of turning on the receiver, so start by ensuring everything is off, then power up the receiver.

- 1 Press and hold buttons 1 and 2, then turn Transmitter **ON**
- 2 Wait until both LEDs go solid, then release the buttons, you are now in calibration mode and the only exit is to power off the transmitter.
- 3 LED2 now indicates which servo is being set, one flash for SERVO 3 and 2 flashes for SERVO 4. Use button 2 to move to the next one.
- 4 Set the S1 (Regulator) knob to fully Anticlockwise for Momentary or fully Clockwise for latching mode.
- 5 Press button 3 to save this setting.
- 6 Proceed with further settings OR power off the transmitter to leave the procedure.

For further advice, contact us by email at: [sales@fosworks.co.uk](mailto:sales@fosworks.co.uk) or call us on 01254 814675