

# OMNI Tx-2.1 ESC 2.4GHz Handheld Transmitter

You no longer need that big transmitter anymore! The programmable **OMNI Tx-2.1 ESC** handheld transmitter will control your garden railway electric locomotives perfectly from the palm of your hand. An **Omni Rx-2 or RX22** receiver will be needed to work with it to control your model. Our 2.4GHz technology is designed for the best results in a garden environment, which can have high levels of activity in the 2.4 GHz spectrum and is quite different to systems designed for model aeroplanes.

**2.4GHz gives perfect glitch free control for up to 800 metres range.**

The Regulator Knob controls speed and direction. Forwards to the right, reverse to the left. The three buttons on the top provide functions for sound cards or can be used to switch on lights etc. Cruise control is possible by turning off the transmitter while the train is running. Turn back on to instantly regain control. A controlled **E-stop** is achieved by moving the knob fully to the opposite direction

## Black Push Buttons 1. 2. and 3

Buttons 1,2, and 3. Operate negative ground functions On a OMNI Rx2 receiver. These buttons are also used to re-program a receiver.

## LED's 1 & 2

Indication of battery and radio status plus indications during bind and calibration.

## ON/OFF Slide switch

Slide down for ON

## Inertia Knob

for super delay accelerations and decelerations. Turn to Zero to switch off as shown

2 x AAA Battery box lid

If Alkaline batteries are used up to 200 hours of continuous use is possible



## More Info

For more information see overleaf

## Regulator Knob

Turn right for forwards and left for reverse. The further you turn, the faster the loco goes. Centre Stop.

Whilst moving, if a quick stop is needed, move the knob fully to the opposite direction for a controlled **E-stop** (Max 2 secs from full speed)

Perfect smooth control to the exact position shown on the regulator dial. This knob is also used when reprogramming the top buttons.

# OMNI Tx-2.1 ESC

Programmable 2.4GHz Transmitter

## With Inertia

Another

**PETER SPOERER**

PRODUCT MADE BY



P.O.Box 675  
Blackburn, Lancs.  
BB1 9DL  
UK

WWW.FOSWORKS.CO.UK  
Tel 0(44)1254 814675



Regulator Knob Forwards and backwards with centre stop  
Inertia control for super delay accelerations and stopping  
Plus three other function buttons for sound cards etc.

With **E**mergency stop function

2.4GHz Technology by Timpdon Electronics

Requires an **OMNI Rx-2 or Rx22** receiver.

Rx-22 receiver circuit diagram for use with a Universal Steam Sound card and 100W Cobra with directional lighting

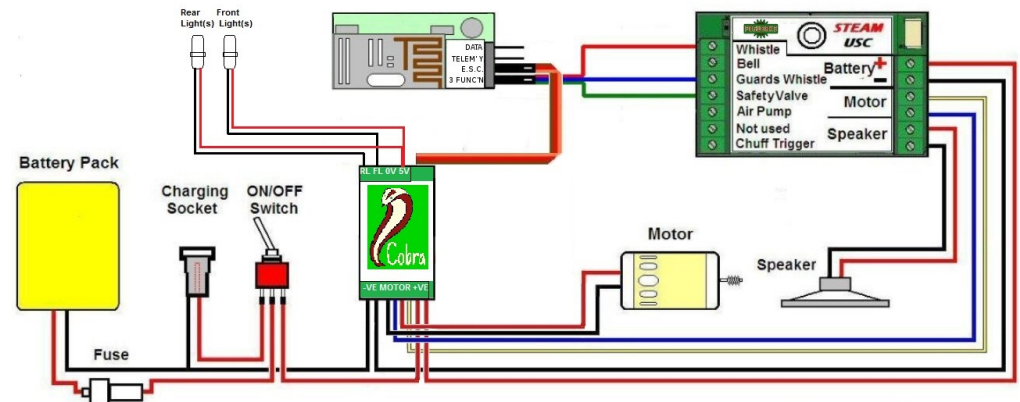

## Binding Procedure.

Now simpler than ever!

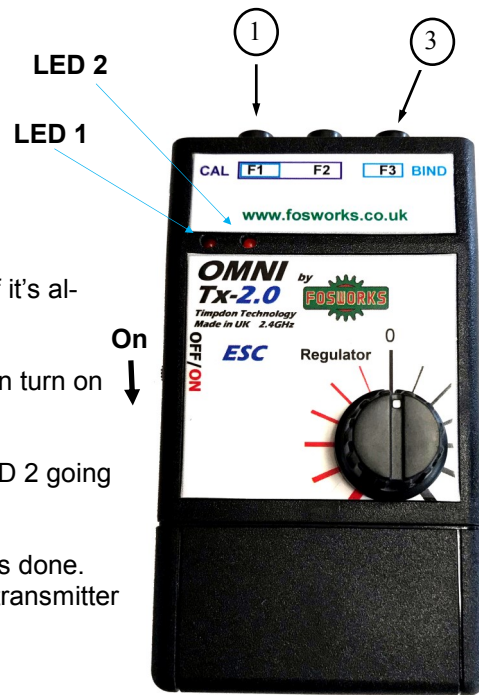

1. Turn on the Receiver (or the model, if it's already fitted inside), then....
2. Hold down black buttons 1 and 3, then turn on the transmitter
3. Successful binding is indicated by LED 2 going ON.
4. Release the two buttons and the job is done. LED 1 goes solid to indicate that the transmitter and receiver are linked.

## Low battery warning

When the batteries in the handset get too low for reliable operation, both LED 1 and 2 start flashing together. Replace them with quality alkaline AAA cells for the best results,

---

## Programming the OMNI system to suit your needs.

Your OMNI transmitter and receiver comes to you all pre-set and ready to run regular electric trains. Forwards and Backwards are on the regulator knob and the three top black buttons can activate sounds via a momentary negative ground facility. Normally there should be no need to change these settings, however...

The OMNI R/C system is ideal, in that when you wish to re-program it to suit the special needs for a particular loco, it is not the transmitter you are re-programming, but the receiver in the loco. The transmitter tells the receiver what is expected of it in the future, and it is the receiver that remembers it. In this way, one OMNI transmitter can control many different types of locos, each with its own very different requirements.

It is possible to change all or just one of the top black buttons from momentary to latching. The regulator knob can have its centre stop position changed too.

## Re-Programming the top Buttons for momentary or latching operation

(All are momentary by default, except F1 on Rx24 DCC receivers, which is latching by default)

This procedure must be started within 20 seconds of turning on the receiver, therefore start with the transmitter off and the model switched on. See our website for a link to video instructions.

First you must put the transmitter into **Button Calibration Mode** :-

1. With the Transmitter turned **Off**. Press and **hold button 1 and 2**.
2. Turn the Transmitter **On**.
3. Both LED's will start flashing, then go solid, indicating successful entry to the Button Calibration mode. At this point, **release** the two buttons. LED 2 now starts flashing.

Once in Button Calibration Mode, there is no exit except Transmitter power **Off**.

### CHANGING BUTTONS FROM MOMENTARY TO LATCHING

The Regulator control knob is used to change the function of a button from latching to Momentary or Vice Versa. Turn it in the desired direction and the given button will be changed.

Fully **anti-clockwise** = **Momentary**      Fully **clockwise** = **Latched**

Press the required buttons to save the setting for a function.

For example if you want function 12 to be latching, turn the regulator fully clockwise and press both shift buttons followed by button 3.

You can now select another button to change, or turn the transmitter off.

Should you wish to reset the centre Off stop position, please contact me by email at

[sales@fosworks.co.uk](mailto:sales@fosworks.co.uk)

If you do not have a computer, please call us on 01254 814675