

OMNI Tx-2.2ESC 2.4GHz Handheld Transmitter

You no longer need that big transmitter anymore! The programmable **OMNI Tx-2.2** handheld transmitter will control your garden railway electric locomotives perfectly from the palm of your hand. An **Omni Rx-2** receiver will be needed to work with the **OMNI Tx-2.1** transmitter.

2.4GHz gives perfect glitch free control for up to 200 metres range.

The Regulator Knob controls speed and the Reverser switch controls direction. The three buttons on the top provide functions for sound cards or can be used to switch on lights etc. Cruise control is possible by turning off the transmitter while the train is running. Turn back on to instantly regain control.

Black Push Buttons 1. 2. and 3

Buttons 1,2, and 3. Operate negative ground functions On a OMNI Rx2 receiver. These buttons are also used to re-program a receiver.

LED's 1 & 2

Indication of battery and radio status plus indications during bind and calibration.

ON/OFF Slide switch

Slide down for ON

Inertia Knob

for super delay accelerations and decelerations. Turn to Zero to switch off as shown

2 x AAA Battery box lid



More Info

For more information see overleaf

Reverser Switch

Select forward, OFF or reverse

Regulator Knob

Turn fully ANTICLOCKWISE for STOP and fully CLOCKWISE for full power. The further you turn, the faster the loco goes.

Perfect smooth control to the exact position shown on the regulator dial. This knob is also used when reprogramming the top buttons.

If Alkaline batteries are used up to 200 hours of continuous use is possible

OMNI Tx-2.2ESC

Programmable 2.4GHz Transmitter

With Inertia

Another

PETER SPOERER

PRODUCT MADE BY



P.O.Box 675
Blackburn, Lancs.
BB1 9DL
UK

WWW.FOSWORKS.CO.UK
Tel 0(44)1254 814675



Full travel Regulator Knob with Reverser switch
Inertia control for super delayed accelerations and stopping
Plus three other function buttons for sound cards etc.
2.4GHz Technology by Timpdon Electronics
Requires an **OMNI Rx-2 or Rx22** receiver.

Rx-22 receiver circuit diagram for use with a Universal Steam Sound card and 100W Cobra with directional lighting

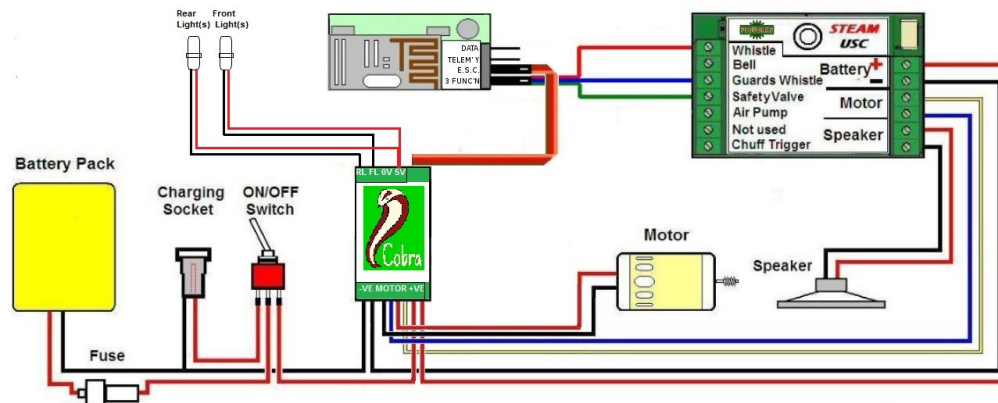

Binding Procedure.

Now simpler than ever!

1. Turn on the Receiver (or the model, if it's already fitted inside), then....
2. Hold down black buttons 1 and 3, then turn on the transmitter
3. Successful binding is indicated by LED 2 going ON.
4. Release the two buttons and the job is done. LED 1 goes solid to indicate that the transmitter and receiver are linked.



Low battery warning

When the batteries in the handset get too low for reliable operation, both LED 1 and 2 start flashing together. Replace them with quality alkaline AAA cells for the best results,

Programming the OMNI system to suit your needs.

Your OMNI transmitter and receiver comes to you all pre-set and ready to run regular electric trains. Forwards and Backwards are on the regulator knob and the three top black buttons can activate sounds via a momentary negative ground facility. Normally there should be no need to change these settings, however...

The OMNI R/C system is ideal, in that when you wish to re-program it to suit the special needs for a particular loco, it is not the transmitter you are re-programming, but the receiver in the loco. The transmitter tells the receiver what is expected of it in the future, and it is the receiver that remembers it. In this way, one OMNI transmitter can control many different types of locos, each with its own very different requirements.

It is possible to change all or just one of the top black buttons from momentary to latching. The regulator knob can have its centre stop position changed too.

Re-Programming the top Buttons for momentary or latching operation

See our website for a link to video instructions.
(All are momentary by default)

This procedure must be started within 20 seconds of turning on the receiver:

1. Start by switching on the model, so that the receiver is **ON**.
2. With the Transmitter turned **OFF**. Press and **hold button 1 and 2**.
3. Turn the Transmitter **ON**.
4. Both LED's will start flashing, then go solid, indicating successful entry to the Button Calibration mode. At this point, **release** the two buttons. LED 2 now starts flashing.

Once in Button Calibration Mode, there is no exit except Transmitter power **Off**.

CHANGING BUTTONS FROM MOMENTARY TO LATCHING

The direction switch and regulator knob are used to change the function of a button from latching to Momentary or Vice Versa. Put the regulator knob to the full power position and set the reversing switch to the desired direction and then simply press the buttons as required to set them to that state.

Full power **Reverse** = **Momentary** Full power **Forward** = **Latched**

Press the required buttons to save the settings for those functions.

For example if you want function 2 to be latching, switch to forward and press button 2.

You can now change another button, or simply turn the transmitter off to exit the calibration routine.

If you need further assistance, please email us at:

sales@fosworks.co.uk

If you do not have a computer, please call us on 01254 814675