

OMNI Tx-4.3 DCC 2.4GHz Handheld Transmitter

You no longer need that big transmitter anymore! The programmable **OMNI Tx-4.3** handheld transmitter will control your garden railway electric locomotives perfectly from the palm of your hand. An **Omni Rx-24** receiver will be needed to work with the **OMNI Tx-4.3** transmitter in DCC mode, but the Tx4.3 will also operate our standard r/c Rx22 receivers installed in analogue DC models.

2.4GHz gives perfect glitch free control for up to 800 metres range with no obstructions.

The Regulator Knob controls speed and direction. Forwards to the right, reverse to the left. Cruise control is possible by turning off the transmitter while the train is running. Turn back on to instantly regain control.

FUNCTION Buttons 1.2.3 / 4.5.6 / 7.8.9 / 10.11.12

Buttons 1.2.and 3. Operate DCC command functions

On a OMNI Rx4 receiver. These buttons are also used to re-program a receiver. Functions 4,5,and 6 are operated by holding the green shift button first, buttons 7,8 and 9 by holding the red shift button first and functions 10,11 and 12 by holding down both shift buttons whilst pressing the function button required.

Selector

Switch to change between **THREE** different receivers

LED's 1 & 2

Indication of battery and radio status plus indications during bind and calibration.

ON/OFF

Slide Switch

Slide down for ON

Inertia Knob

Use it for super smooth acceleration and deceleration. Minimum 1 second.

2 x AAA Battery box

If Alkaline batteries are used up to 100 hours of continuous use is possible



Shift Buttons

Green and Red

Enable F4 to F12 in combination with black buttons. E.g. **F7** is obtained by pressing and holding the **RED** button then pressing **BLACK** button F1. Hold both down to obtain F10, F11 and F12.

Regulator Knob

Turn right for forwards and left for reverse. The further you turn, the faster the loco goes.

Centre Stop.

Whilst moving, if a quick stop is needed, move the knob fully to the opposite direction for a controlled **E-stop** (Max 2 secs from full speed)

This knob is also used when reprogramming the top buttons.

OMNI Tx-4.3 DCC

Programmable 2.4GHz Transmitter

For simultaneous control of up to 3 models and 12 functions on each model.



P.O.Box 675,
Blackburn, Lancs.
BB1 9DL
UK

WWW.FOSWORKS.CO.UK
Tel 01254 814675



Regulator Knob Forwards and backwards with centre stop
Inertia control for super smooth acceleration and braking
Selector switch allows **three** models to be run simultaneously
Plus **12 functions** for **DCC** or DC operation
2.4GHz Technology by Timpdon Electronics
With **Emergency stop** function

Requires an **OMNI Rx24 or Rx4** receiver with DCC interface module or OMNI Rx22 or Rx2 with optional MCS switchers

Rx-24 receiver circuit diagram showing optional use of ESC. Note that standard Rx24 do not have the ESC connection, Rx24-ESC must be ordered specially. There are several versions including Drivelock on F8.

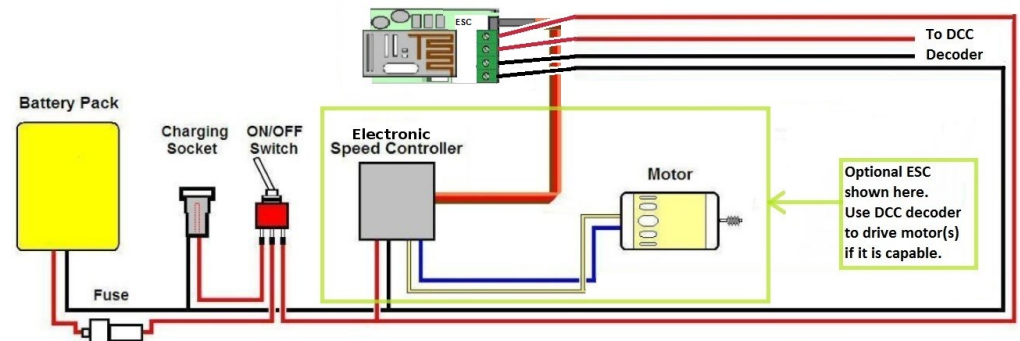

Binding Procedure.

Now simpler than ever!

1. Turn on the Receiver (or the model, if it's already fitted inside) then....
2. Move Selector switch to position desired for the model.
3. Hold down black buttons 1 and 3, then turn on the transmitter
4. Successful binding is indicated by LED 2 going ON.
5. Release the two buttons and the job is done. LED 1 goes solid to indicate that the transmitter and receiver are linked.

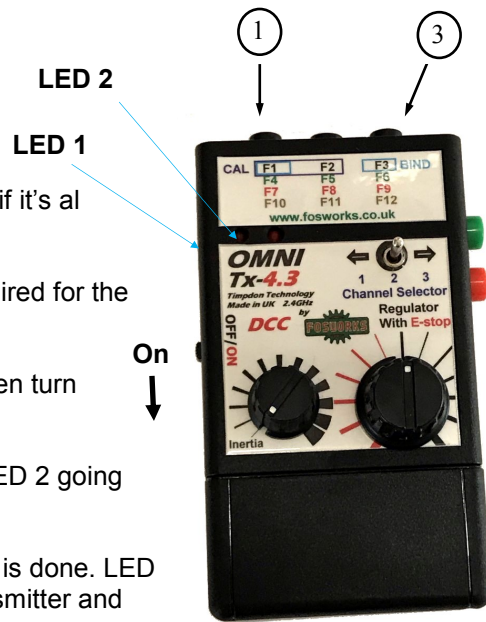

Re-Programming the top Buttons for momentary or latching operation

(All are momentary by default, except F1 on Rx24 DCC receivers, which is latching by default)

This procedure must be started within 20 seconds of turning on the receiver, therefore start with the transmitter off and the model switched on. See our website for a link to video instructions.

First you must put the transmitter into **Button Calibration Mode** :-

1. With the Transmitter turned **Off**. Press and **hold button 1 and 2**.
2. Turn the Transmitter **On**.
3. Both LED's will start flashing, then go solid, indicating successful entry to the Button Calibration mode. At this point, **release** the two buttons. LED 2 now starts flashing.

Once in Button Calibration Mode, there is no exit except Transmitter power **Off**.

CHANGING BUTTONS FROM MOMENTARY TO LATCHING

The Regulator control knob is used to change the function of a button from latching to Momentary or Vice Versa. Turn it in the desired direction and the given button will be changed.

Fully **anti-clockwise** = **Momentary** Fully **clockwise** = **Latched**

Press the required buttons to save the setting for a function.

For example if you want function 12 to be latching, turn the regulator fully clockwise and press both shift buttons followed by button 3.

You can now select another button to change, or turn the transmitter off.

Should you wish to reset the centre Off stop position, please contact me by email at sales@fosworks.co.uk

If you do not have a computer, please call us on 01254 814675

Low battery warning

When the batteries in the handset get too low for reliable operation, both LED 1 and 2 start flashing together. Replace them with quality alkaline AAA cells for the best results,

- Programming the OMNI system to suit your needs.

The OMNI R/C system is ideal, in that when you wish to re-program it to suit the special needs for a particular loco, it is not the transmitter you are re-programming, but the receiver in the loco. The Transmitter tells the receiver what is expected of it in the future, and it is the receiver that remembers it. In this way, one OMNI transmitter can control many different types of locos, each with its own very different requirements.

It is possible to change all or just one of the functions from Momentary to latching.