



BBCNEWSLETTER 2023.06.26

BALLINA BICYCLE CLUB RIDE ATTENDEES

For the week – 34 - For week ending Sun 25JUN2023.

Monday – 9 (See report)

Tuesday – 3 (See report)

Wednesday – 5 (See report)

Thursday- 1 ()

Friday – 5 (See report)

Saturday – ? ()

Sunday – 11 (See report)

Join our mailing list: bbclubnews@gmail.com

4 Week Free Trial Memberships

[BBC Certificate of Currency](#)

are available to anyone who has not held an AusCycling membership in the last 3 years.

CLICK TO OPEN



BBC MEMBERSHIP & INSURANCE

KEY: **GREEN**(slow) **BLUE**(med-fast)
UPCOMING EVENTS

CLICK ON EVENT TO OPEN

WOODBURN

JUN Tue 27th 7AM. Coles, Fox St.

HOUGHLAHANS MTB

JUN Wed 28th 7AM. Coles, Fox St.

WARDELL 2

BROADWATER

JUN Fri 30th 7AM. Coles, Fox St.

RIDERS CHOICE

JUL Sat 1st 7AM. Henry Rous Tavern

COOPERS SHOOT

COMBINED MEMORIAL RIDE

JUL Sun 2nd 7AM. Coles, Fox St.

MOYLANS-WARDELL

JUL Mon 3rd 7AM Coles, Fox St.

Monday Ride Report

- Peter



Does anybody know what this is for?

Nine riders; Tom, Richard (shorty), Anthony, Bob, 2Bob, David, Dave, Bruce and myself, left Coles to ride to Wardell. From the ferry, this group split up into two, then later a third. Tom, Dave, Shorty and myself went at a steady cruisy pace at 27-28 kph. The others were even more relaxed. It was a great sunny cool day for a ride.

On the return trip, David, Tom, Shorty and Tom did an extra 4 kilometres via Moylans lane. The pace went up only slightly, yet fast enough to catch the others who ride straight to the ferry. A third group of two, including 2Bod and I think Dave, branched off to include South Ballina to their ride.

While waiting for the ferry I saw a strange bollard attached to a cement slab. I have no idea what it is for, neither does the ferry master. Do you know? See picture above.

Tuesday Ride Report

- David and Peter

Two riders, Gavin and Dave turned up for the trip. The route followed Pimlico Road and Blackwall Road via Wardell and Broadwater to Woodburn. This is the flat route to Woodburn and allows for the trip to become a loop so the scenery is never repeated.

Return was via Kilgin and Bagotville Roads, Wardell Road and River Road. The riding conditions were near perfect with a gentle south westerly wind. This of course became a tailwind producing a very enjoyable return.

Riding speed was 27-28 km/hr for the outbound trip with a little higher on the tail wind return. This is my favourite ride of the week and should be able to be enjoyed by a host of riders given the modest

speed. Longer rides create a definite fitness improvement and a sense of accomplishment so join us and give it a try.

- David

I left later in the morning, 11am actually, hoping for some warmer weather. There was a bit of a stiff WSW wind to deal with, and it chilled the air by a few degrees. It seems one cannot really plan too far ahead with certainty.

The headwind to Wardell forced me to use the small chainring. While travelling at a much slower pace I realized how much of a slow learner I really am. It occurred to me that there is another reason for getting tired while negotiating headwinds. Besides changing ones own aerodynamic position, gearing, and pace, there is the fact that in a lower gear one pedals a *hell of a lot more* just to cover the distance to Wardell... something I never considered before.

The trip back was a breeze in more ways than one. In any case, I did not fang it, I just took it easy today. Tomorrow will be different because I will be riding with Marc Mears, and he is more than likely to give me a hard time.

- Peter

Wednesday Ride Reports

- Peter

Marc Mears and myself left Ballina at 6:30am for our Wardell circuit. The morning temperature dropped down more than ever this year. Our unprotected fingers pained us as the wind-chill factor rose with our speed. Luckily we felt some relief as the sun was coming up. Our pace was okay most of the way, but for some reason we both struggled for the last five kilometres to the ferry and hardly got past 31 kph. The good thing about having an early morning coffee at Babalino's Bakery is sitting in the rising warmth of the sun.

David, Tom and Garry rode the Houghlahans circuit. They too found it very cold this morning. Just to keep warm they decided not to stop where they normally do. They got back half an hour earlier, and as a consequence I met them at the Proper Cafe just as they were leaving to go home. Oh well, I really didn't need a second cuppa, so I walked back home.

Friday Ride Report

- Peter

Five riders – David, Tom, Anthony, Buster and Peter – rode the short route version to Wardell and back to the ferry. Tom led most of the way at a cruising pace of 28 kph. Within a few metres from our Wardell departure, David got a rear flat tyre. Instantly we knew we will be hanging around for quite awhile. Not because David is slow, but his rear wheel is slightly larger in diameter for servicing any tyre. But we all were use to this, even when he got another flat tyre a few kilometres up the road. This time it took Tom and myself to find the cause of the repeated offence – a slither of glass.

We eventually got back for our cuppa and usual chinwag. David now and again sports an [Errol Flynn](#) moustache after sipping his cappuccino, and today he did not disappoint. Besides, when you are 80 years old you tend think you may get away with anything.



TOM

BUSTER



ANTHONY



DAVID

Sunday Ride Report

- Simon and David

There were initially three of us for this month's vintage ride. Gavin on his trusty 1970's Colnago Super, Mark on his neo-retro 1980's Mercier with the incredible paint job, and myself on a 1977 Lennie Rogers. The course I had designed seemed to put a few off as being unsuitable for old bikes and I apologise for that. As it turned out the course was vetoed and the favourite Dungarubba course was ridden instead. Adam joined us at West Ballina on an early 2000's Carrera. The trip to Broadwater was often punctuated by comments about toes falling off because of the cold. Broadwater offered some sun to thaw us out and by the time we reached the ferry we were all warmed up again. It was a sparkling morning and riding up the river to Ballina was glorious. Coffee in Ballina topped it off.

- Simon



Four faster riders Mark, Mark, Richard and Dave barrelled down the freeway to Broadwater with the aid of a slight tailwind. Mark M. was expecting a steely ride but no other steelies turned up by 7AM so he joined in. This could have been fortunate as the steel bike route nominated was over 64 km with lots of climbing which Mark does not love. Today's ride did not include any hills.

This route was chosen because it is several km longer than the old Pacific Highway which was the choice of the slower group comprising Tony, Bobby, 2 Bob, Gary, Dave 2 part time and Buster. This worked well because the slower group arrived at the amenities centre just as the faster group was about to return.

Both groups returned via the old Highway in time to enjoy a communal coffee at the Proper Cafe.

- David

OTHER BITS & PIECES Click on the 2 images below to open



6-DAY BALLINA (FORECAST). Click image to open METEYE (2478 for Ballina).



Forecast for East Lismore						
	Tue. 27 Jun	Wed. 28 Jun	Thu. 29 Jun	Fri. 30 Jun	Sat. 1 Jul	Sun. 2 Jul
Max (°C)	21	21	20	20	20	18
Min (°C)	2	4	7	3	3	4
Chance of rain (%)	5	20	20	5	10	60
Rainfall range (mm)	0	0	0	0	0	0 to 4

Where to Race

Here are a few links for our racing club members to represent our club in:

- Byron Bay** <https://www.byronbaycycleclub.org.au/home-1> and/or <https://www.facebook.com/byronbaycycleclub/>
- Yamba** <https://yambacc.tidyhq.com/> and/or <https://www.facebook.com/YambaCC/>
- Murwillumbah** <https://murwillumbah.tidyhq.com/> and/or <https://www.facebook.com/MurbahCycleClub/>
- Grafton** <https://graffton.tidyhq.com/> and/or <https://www.facebook.com/grafftoncycleclub/>
- Grafton Events Feb-Jun:** https://drive.google.com/file/d/138CvHjUyUg0HYkXqSbQhMdP2EBErHOQb/view?usp=share_link

Where to Trail Ride

Here are a few links for our MTB club members to represent our club in:

- Kyogle MTB Club:** <https://www.facebook.com/kyoglemountainbikeclub>

SPONSORSHIP NEWS



THE BICYCLE EMPORIUM
158 River Street Ballina
<http://thebicycleemporium.com.au/index.html>

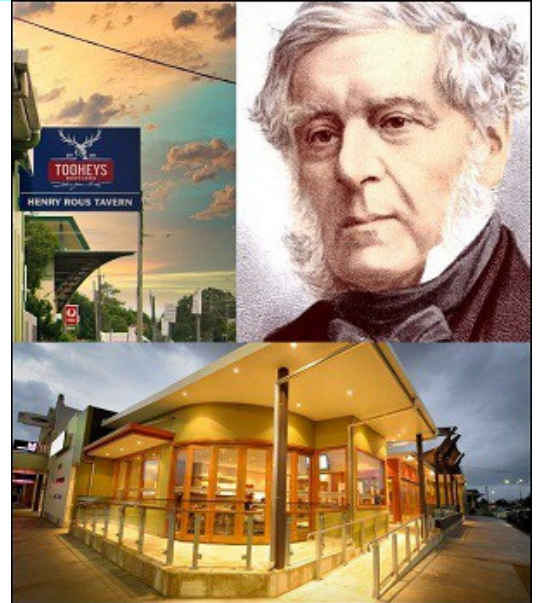

THE HENRY ROUS TAVERN
177 River Street Ballina
<https://www.henryrous.com.au>



SPOT THE DIFFERENCE The right-hand image has 10 alterations. Can you spot them?

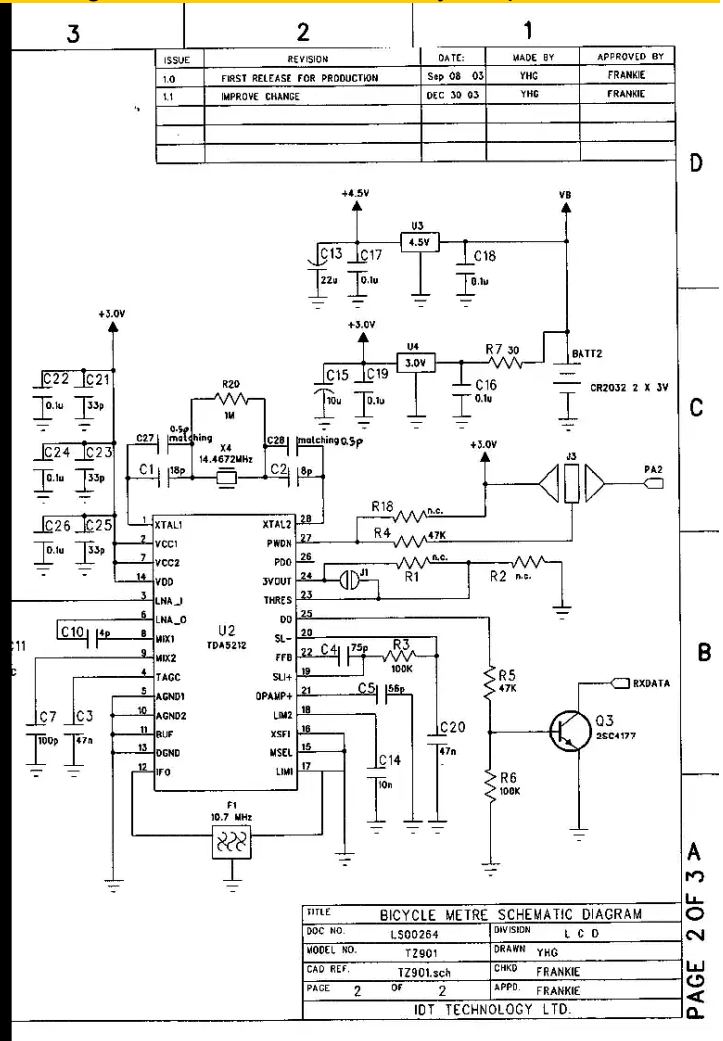
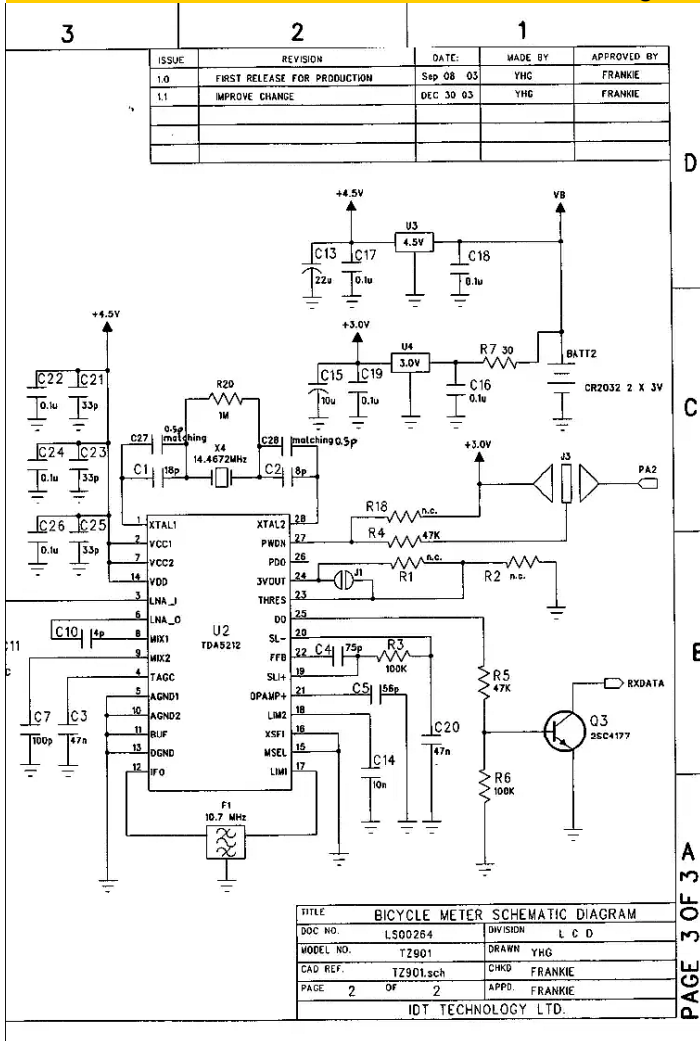

Answer: <https://drive.google.com/file/d/1JusmqC4ubcPdDTgj5s-pZISNUMR1CpDY/view?usp=sharing>



GET YOUR FREE BBC NEWSLETTER SUBSCRIPTION: email me at... bbclubnews@gmail.com
BBC Newsletter Archives: <https://ballinabicycleclub.org/newsletters-1>
BBC WEBSITE: <https://ballinabicycleclub.org>

Our Disclaimer: The opinions expressed by contributors in BBC NEWS are theirs alone and do not reflect the opinions of the Ballina Bicycle Club or its Members. BBC is not responsible for the accuracy of any of the information supplied by the contributors... :)