



BBCNEWSLETTER 2023.09.04

BALLINA BICYCLE CLUB RIDE ATTENDEES

For the week – 24 - For week ending Sun 03SEP2023.

Monday – 5 (See report)

Tuesday – 5 (See report)

Wednesday – 4 (See report)

Thursday- ? ()

Friday – 10 (See report)

Saturday – ? ()

Sunday – ? ()

Join our mailing list: bbclubnews@gmail.com

4 Week Free Trial Memberships

[BBC Certificate of Currency](#)

are available to anyone who has not held an AusCycling membership in the last 3 years.

CLICK TO OPEN



BBC MEMBERSHIP & INSURANCE

KEY: GREEN(slow) BLUE(med-fast)

UPCOMING EVENTS

CLICK ON EVENT TO OPEN

WOODBURN

SEP Tue 5th 7AM. Coles, Fox St.

TUCKEAN ISLAND MTB

SEP Wed 6th 7:30AM. Wardell tennis crts.

WARDELL 2

BROADWATER

SEP Fri 8th 7AM. Coles, Fox St.

RIDERS CHOICE

BROADWATER

SEP Sun 10th 7AM. Coles, Fox St.

TIME TRIAL TRAINING

SEP Sun 10th 2PM. Empire vale School.

MOYLANS-WARDELL

SEP Mon 11th 7AM Coles, Fox St.

VINTAGE BIKE RIDE

SEP Sun 17th 7AM. Henry Rous Tavern

Monday Ride Report

- David



Five riders turned up; the smallest number I have ever seen for a sunny Monday ride. Actually, there was four at the start, but Shorty was waiting to join us at the end of Kalinga Street. The five of us (David, Dave, Richard, Shorty and myself) kept at a good cruising speed most of the way.

We stopped at Wardell for a short spell and then headed back to Ballina along Blackwall drive and the Expressway. As we were approaching Ballina, the pace went up to the higher 30s. I was able to enter the roundabout, under the expressway, without holding up traffic. I was impressed with Dave's performance, especially when the pace went up. By the time he got back into Kalinga Street he was drenched from sweat, a sure sign of a good hard workout.

Tuesday Ride Report

- David and Peter

Dave rode solo to Woodburn following the coastal route down and the inland route back. Total distance from his home 102Km. The ride started at 6:30AM from Cole's Liquorland because once again there was rain forecast around 11-12 in the morning. As it turned out again, there was no actual water type rain and the ride finished at 10:20AM.

As Dave was on the return leg 5km north of Woodburn, he passed Richard going the other way. Because the weather can cause planning changes in the departure time and route, any rider wishing to ride with Dave should make contact by SMS before the ride because the ride may not start at 7:00 AM. Dave was not expecting other riders because he has done the ride solo for several weeks.

- David

Marc and myself left Ballina at 7 am for a quick ride to the base of Meerschamvale hill via Wardell. Along Blackwall drive I got a rear wheel puncture. To be honest, I was half glad it happened because it gave me a breather from keeping up with Marc's pace.

Poor Marc waited for me to catch up with him at the top of the small hills. I had no trouble blitzing it on the descents. As we were returning back to Wardell, it was Marc's turn to have a rear wheel puncture (see photo).

Travelling back along the Expressway was quite good drafting behind Marc. I did have a go at leading near the end and was pleased to not have slowed the pace at all. As we were coming into town we saw and waved to Bob going out for his ride. In town, we stopped for refreshments at Babalino's Bakery.

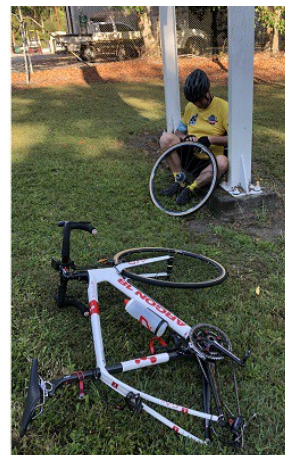

- Peter

Wednesday Ride Report

- David

Four riders went out into ideal riding conditions. Tom and Stewart chose to circle around North Teven but then joined in the remainder of the climbing. We were back at the coffee shop by 08:45 Am because the ride was uninterrupted. This ride always has the best of the district scenery in several ways.

After the ride it was agreed that the next MTB ride on Wed 06 September will be a 7:30 departure from Wardell tennis courts.

NEW MOUNTAIN BIKE ROUTE UPDATE

- David

The plan is to alternate the MTB ride between Tuckean Island and Houghlahans Creek Road on alternate weeks.

The next MTB ride on Wed 06 September will be a 7:30 departure from Wardell tennis courts. The route has the same length as the normal ride but with lots of dirt so that an MTB is definitely required. (No road bikes). The route will follow Wardell Road, Marom Creek Road, Tuckean Island Road, Hoare Lane, Broadwater Road, Bagotville Road and OLD Bagotville Road back to Wardell where a coffee and a hot Wardell pie awaits.

Friday Ride Report

David Collapses

- Peter

Ten riders left at 7am for Wardell. The ten split into two groups. The faster group included David, Gavin, Michael, Tom and Shane. The slower group included Bruce, Kevin, Anthony, Bob and Jack. I did not ride on this day, so my report is based on what others had told me.

On Friday morning at the Proper Cafe I only saw the slower group riders. I assumed that the faster group either got flat tyres or they actually rode an extra 20 kms by going to Broadwater via Bogotville Road, which they sometimes do. The slower group reported having a good untroubled ride, except the usual anxiety of negotiating the Ballina exit roundabout off the Expressway.

After I got back home, I contacted Tom. He reported that after they arrived at Wardell (Fitzroy Park) for a recovery spell, David standing over his bike, suddenly and without warning, collapsed onto the road. Tom and others were trying to assess David's condition when just as suddenly David regained consciousness. The ambulance was called, but David felt he was okay to continue riding; but that idea was halted by the others. It took an hour for an ambulance to arrive; surprisingly from Evans

Head. The paramedics checked David out and he seemed to be okay, but took him to Ballina hospital for a medical examination. Later that day, David was sent to John Flynn Hospital in Queensland for an angiogram. Result showed that his heart was okay but he suffered from some arterial blockage...



I just got off the phone to David (6pm). He just came out of surgery. The surgeons located the blockage which was near his twenty year old stent. The dissolved the blockage and put in another stent. David is both very happy and relieved that his condition was not worse. He is, as I write, awaiting to hear from the surgeons about his operation.

I won't be surprised to see David soon on his bike, and giving us a hard time of it too. . . Not bad for an eighty year old athlete.

OTHER BITS & PIECES Click on the 4 images below to open



Where to Race

Here are a few links for our racing club members to represent our club in:

Byron Bay <https://www.byronbaycycleclub.org.au/home-1> and/or <https://www.facebook.com/byronbaycycleclub/>

Yamba <https://yambacc.tidyhq.com/> and/or <https://www.facebook.com/YambaCC/>

Murwillumbah <https://murwillumbah.tidyhq.com/> and/or <https://www.facebook.com/MurbahCycleClub/>

Grafton <https://graffton.tidyhq.com/> and/or <https://www.facebook.com/grafftoncycleclub/>

Grafton Race Calendar (Jul-Sep): <https://drive.google.com/file/d/1nCJEhYz2ZhGNZTezq-T9JNeEmYbPFiOZ/view?usp=sharing>

Where to Trail Ride

Here are a few links for our MTB club members to represent our club in:

Kyogle MTB Club: <https://www.facebook.com/kyoglemountainbikeclub>

GRAFTON GRAVEL X (SEP Sat 30th) and GBOMB (OCT Sun 1st) 2023 POSTER:

https://drive.google.com/file/d/1nSErk2V_fkS30EKUnDQhfFJuvXqdj8He/view?usp=sharing

For more details: <https://drive.google.com/file/d/1dE6LHsluUhxci-tEDZl3Q3cPm2YzCT/view?usp=sharing>

Other Events

Le Tour De Flow: A call for female cyclists for a research project. To view poster:

https://drive.google.com/file/d/1WE_hJ-Tgocgr8uGW1Q8ox1fhdb8vQMU/view?usp=sharing

Lismore Road Race (24th Sep): https://drive.google.com/file/d/1ZRMxGqd5akN0X1i_h-QPZ84N0CwRXZr/view?usp=sharing

For more details: https://drive.google.com/file/d/19upPRDqimmRO1hxVxLdkuvS_C_bAa63D/view?usp=sharing
Hi Cycling Clubs,

I earlier invited you all to our inaugural Road Race being held in Lismore on the 24th September. It promises to be worthwhile with a start and finish in the Lismore CBD and conducted on fully closed roads.

We are raising money for the Westpac Rescue Helicopter Service and providing some entertainment for the local community members as a contribution to their morale and resilience following the devastating 2022 flooding event.

I've attached a poster (and versions for your socials and website if needed) for the race. Would you mind sharing the poster with your club members, and maybe printing a couple of hardcopies to be put up in strategic places (coffee stops) where your local riders will see, that would be brilliant. NB The poster has a QR code that goes to our website/entry portal.

– Cheers, Mat Johnson

LISMORE ROAD RACE

SUNDAY SEPTEMBER 24TH ~ 7AM START



START~ FINISH WOODLARK & MOLESWORTH ST LISMORE

Enjoy a race starting and finishing in the heart of Lismore's CBD taking you through undulating countryside in the picturesque areas of Woodlawn & Numulgi

GRADES ~ MALE / FEMALE A - D GRADES
~ BEGINNER ~ EBIKE



ENTRY VIA ENTRYBOSS

 byronbaycycleclub.org.au



 [byronbaycycleclubinc](https://www.instagram.com/byronbaycycleclubinc)

 secretary@byronbaycycleclub.org.au

Proudly supporting the Westpac Rescue Helicopter Service



SPONSORSHIP NEWS



THE BICYCLE EMPORIUM
158 River Street Ballina
<http://thebicycleemporium.com.au/index.html>

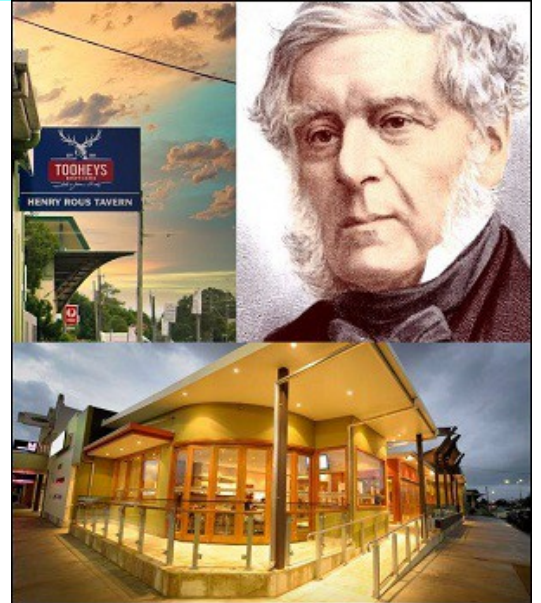

THE HENRY ROUS TAVERN
177 River Street Ballina
<https://www.henryrous.com.au>

6-DAY BALLINA (FORECAST). Click image to open METEYE (2478 for Ballina).



Forecast for Ballina

	Tue. 5 Sep	Wed. 6 Sep	Thu. 7 Sep	Fri. 8 Sep	Sat. 9 Sep	Sun. 10 Sep
Max (°C)	29	24	26	28	22	22
Min (°C)	14	14	12	15	13	12
Chance of rain (%)	20	10	20	20	30	40
Rainfall range (mm)	0	0	0	0	0 to 1	0 to 2

**Dad, you must get home now!
I can't son, I'm in the hospital.
Mom's trying to sell your bikes!**

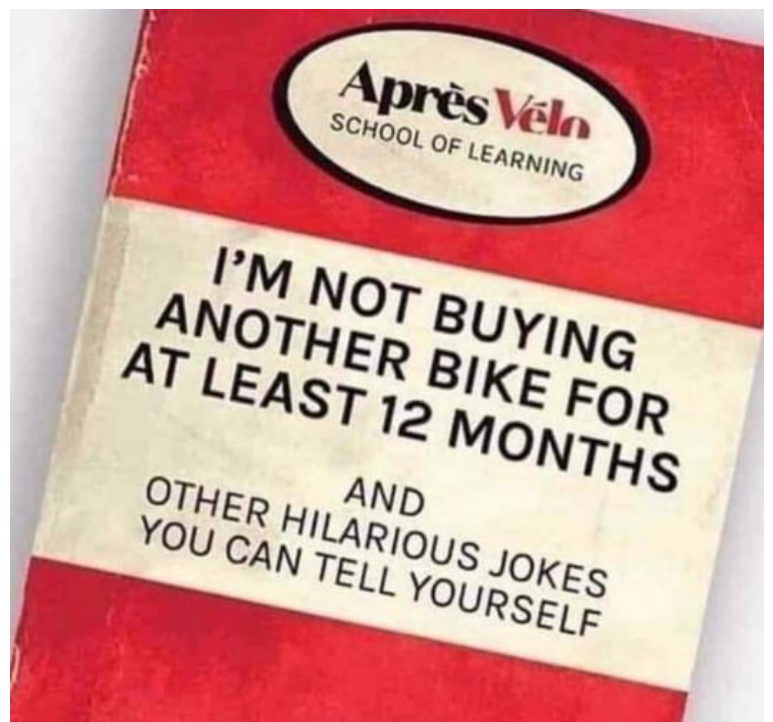

SPOT THE DIFFERENCE The right-hand image has 10 alterations. Can you spot them?

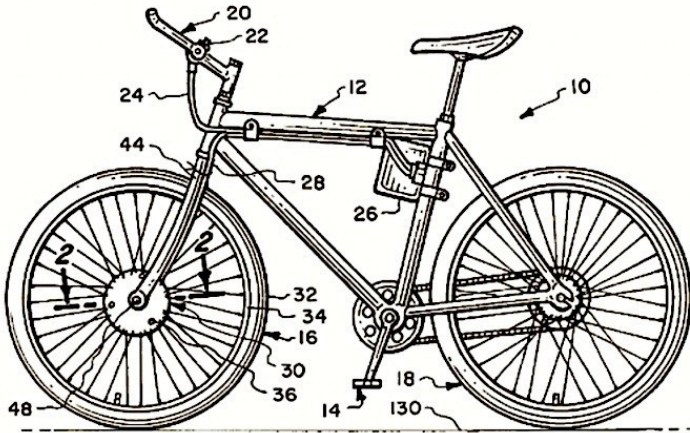

Fig. 1.

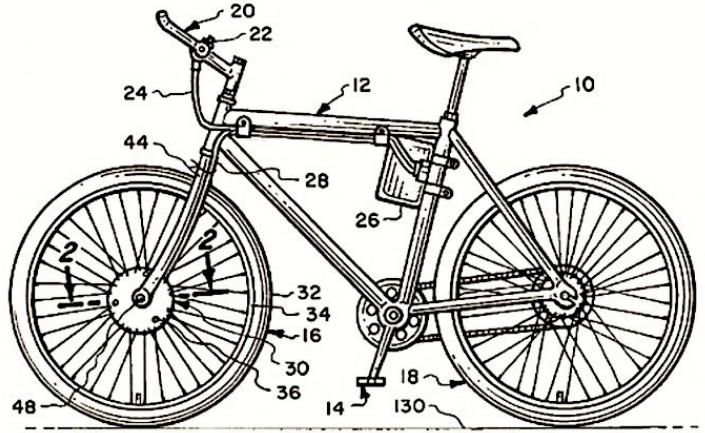
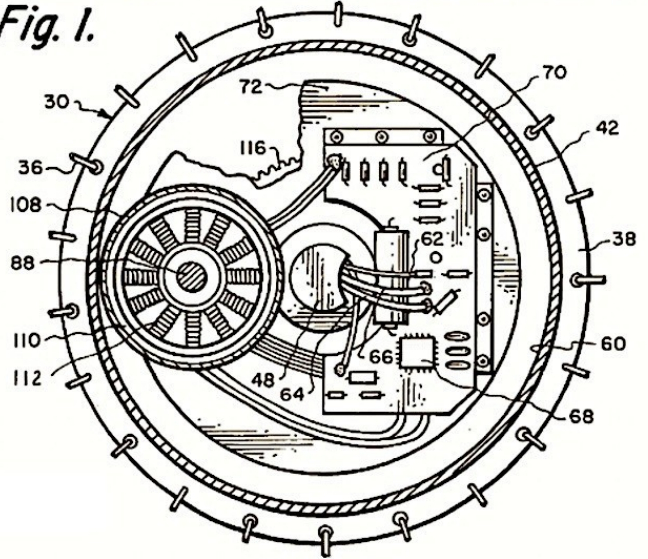
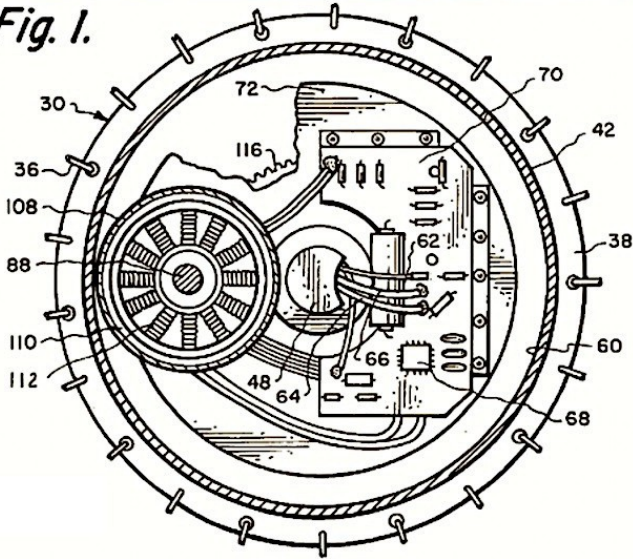

Fig. 1.



Answer: <https://drive.google.com/file/d/1Meku8ibw0wK30F3P113m4rC5l3j3u9ac/view?usp=sharing>



GET YOUR FREE BBC NEWSLETTER SUBSCRIPTION: email me at... bbclubnews@gmail.com
BBC Newsletter Archives: <https://ballinabicycleclub.org/newsletters-1>
BBC WEBSITE: <https://ballinabicycleclub.org>

Our Disclaimer: The opinions expressed by contributors in BBC NEWS are theirs alone and do not reflect the opinions of the Ballina Bicycle Club or its Members. BBC is not responsible for the accuracy of any of the information supplied by the contributors....)