



THE PACIFIC RIM ARABIAN HORSE ASSOCIATION
FALL CLASSIC AHA VALUE SHOW
CO-HOSTED BY THE INLAND EMPIRE ARABIAN HORSE CLUB
SEPTEMBER 23 – 25, 2022
GRANT COUNTY FAIRGROUNDS
MOSES LAKE, WA

TRAIL COURSES AND PATTERNS

PRAHA TRAIL
 Class 1 Arabian English Open
 Class 2 HA English Open
 Class 9 Arabian Western ATR
 Class 10 HA Western ATR

- Be ready at cone
- Jog over poles
- Lope over poles (LL)
- Change leads (flying or simple)
- Lope over poles (RL)
- Jog over poles and through cones to gate
- Open gate, walk through over pole, close gate
- Back into box
- Turn 360 degrees either direction
- Walk over poles and out

WALK	* * * * *
JOG	-----
LOPE	—————
BACK	ε ε ε ε ε

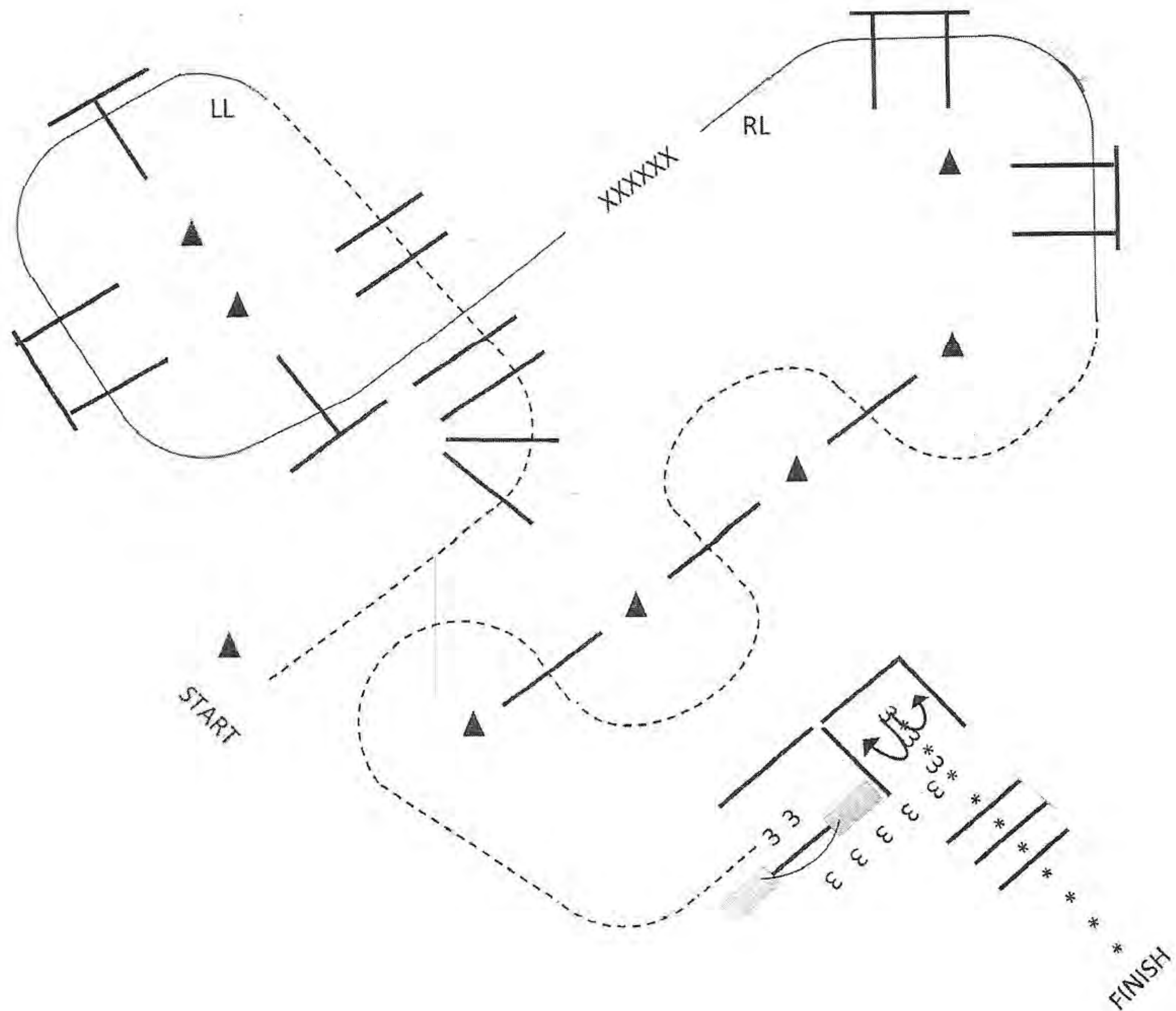

PRAHA TRAIL

Class 3 Arabian English ATR

Class 4 HA English ATR

Class 7 Arabian Western Open

Class 8 HA Western Open

Walk over poles into box.

Turn 360 degrees either direction

Back to gate, open, walk over pole and through gate, close gate

Jog over poles and through cones

Lope over poles (RL)

Change leads (flying or simple)

Lope over poles (LL)

Jog over poles

Stop and walk out

WALK	* * * * *
JOG	-----
LOPE	_____
BACK	ε ε ε ε ε

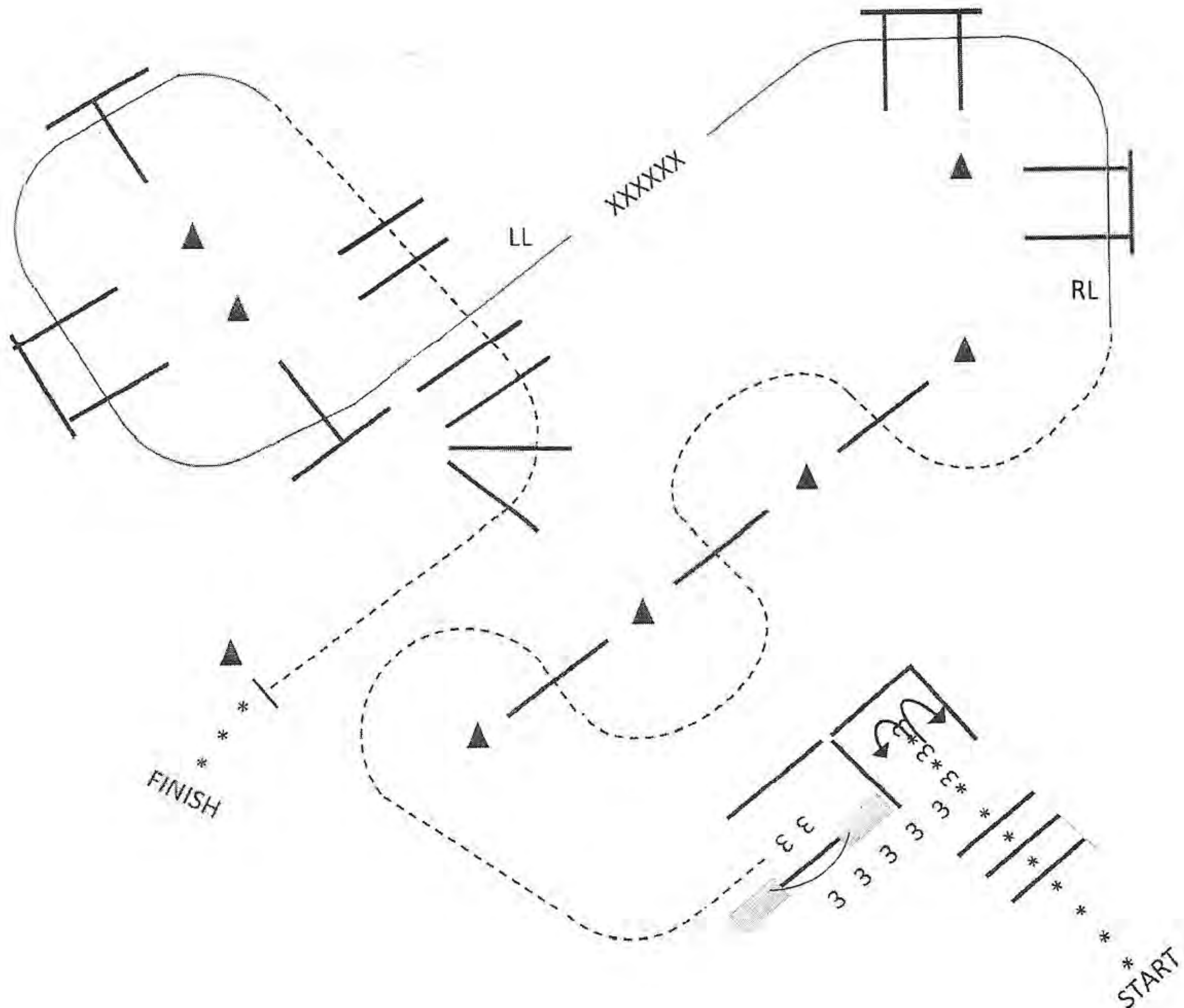

Class 5 Arabian English Green
 Class 6 HA English Green
 Class 11 Arabian Western Green
 Class 12 HA Western Green
 Revised 9/08/2022

Be ready at cone

Jog over poles

Lope over poles (LL)

Change leads (flying or simple)

Lope over poles (RL)

Jog over poles and through cones to gate

Open gate, walk through close gate

Back into box

Turn 360 degrees either direction

Walk over poles and out

WALK	* * * * *
JOG	-----
LOPE	_____
BACK	ε ε ε ε ε

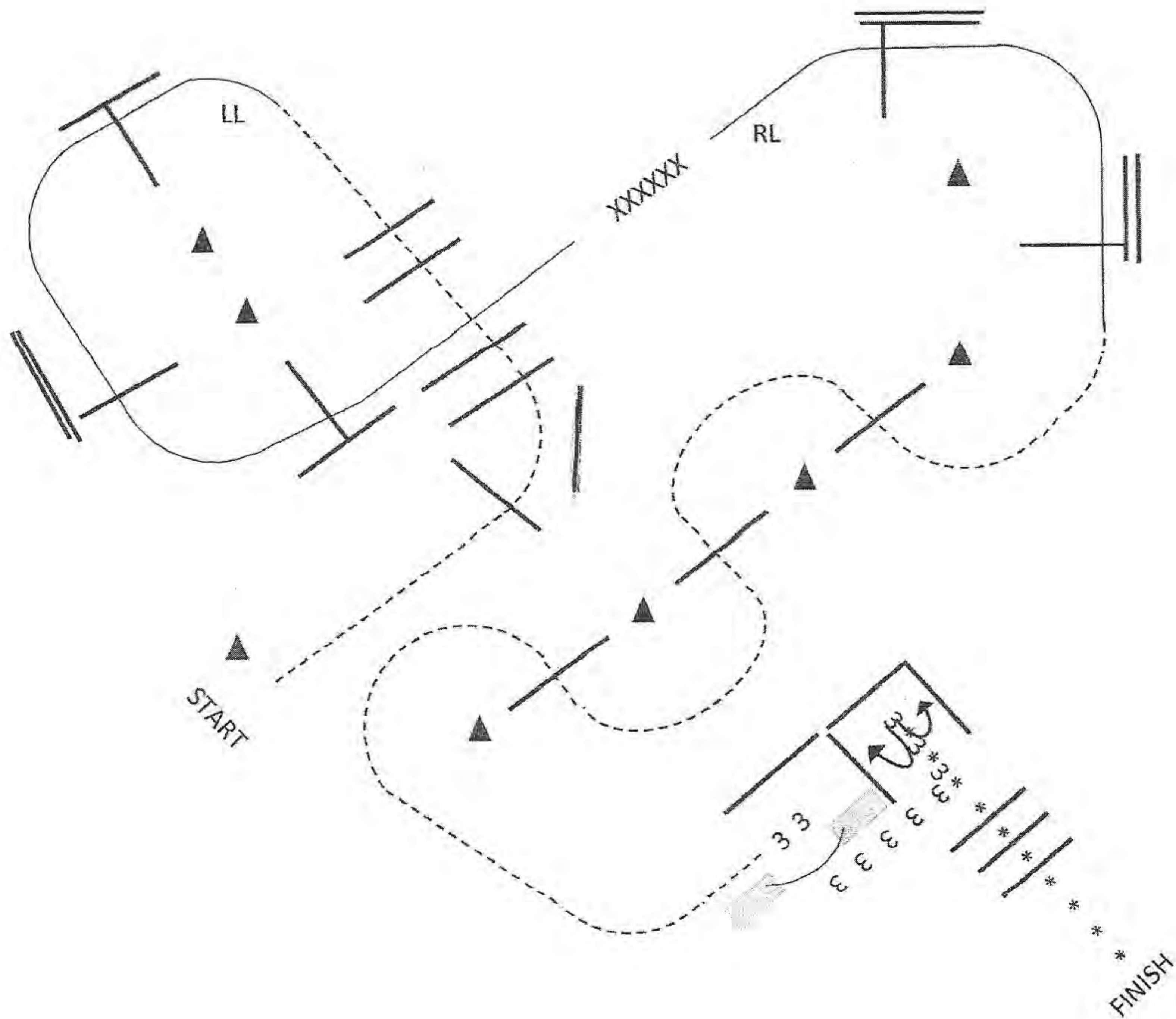

PRAHA TRAIL

Class 13 A/HA/AA Walk/Trot 10 & Under

Revised 09/08/2022

- Walk over poles into box.
- Turn 360 degrees either direction
- Back out
- Walk over pole and through gate
- Jog over poles and through cones
- Jog over poles
- Jog over poles
- Stop and walk out

WALK	* * * * *
JOG	- - - - -
LOPE	_____
BACK	ε ε ε ε ε

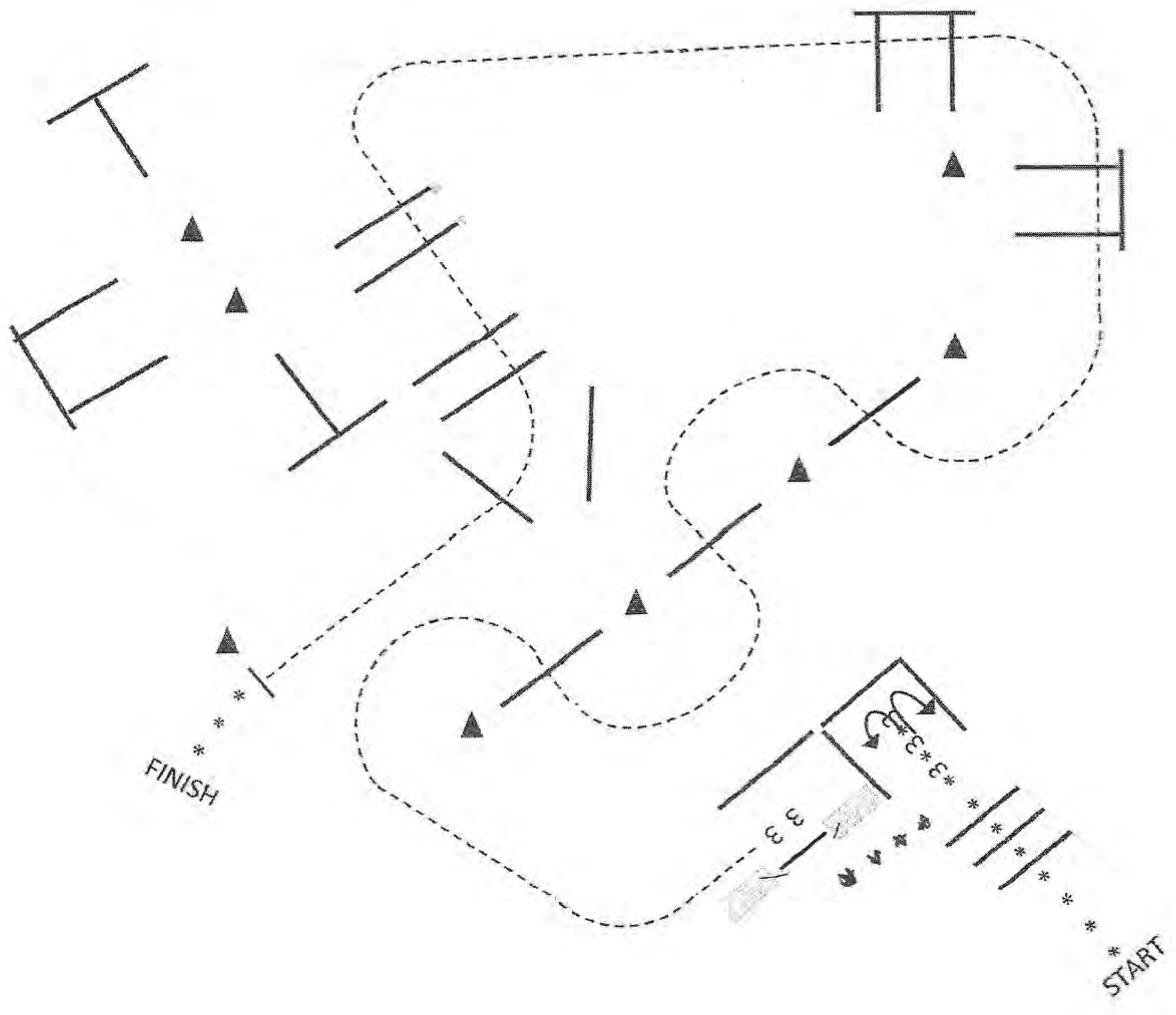

PRAHA TRAIL IN-HAND
 Class 14 Arabian Eng/West
 Class 15 Half-Arabian Eng/West
 Revised 09/08/2022

Walk over poles into box.

Turn 360 degrees either direction

Back to gate, open, walk over pole and through gate, close gate

Jog over poles and through cones

Jog over poles

Jog over poles

Stop and walk out

WALK	* * * * *
JOG	- - - - -
LOPE	— — — — —
BACK	ε ε ε ε ε

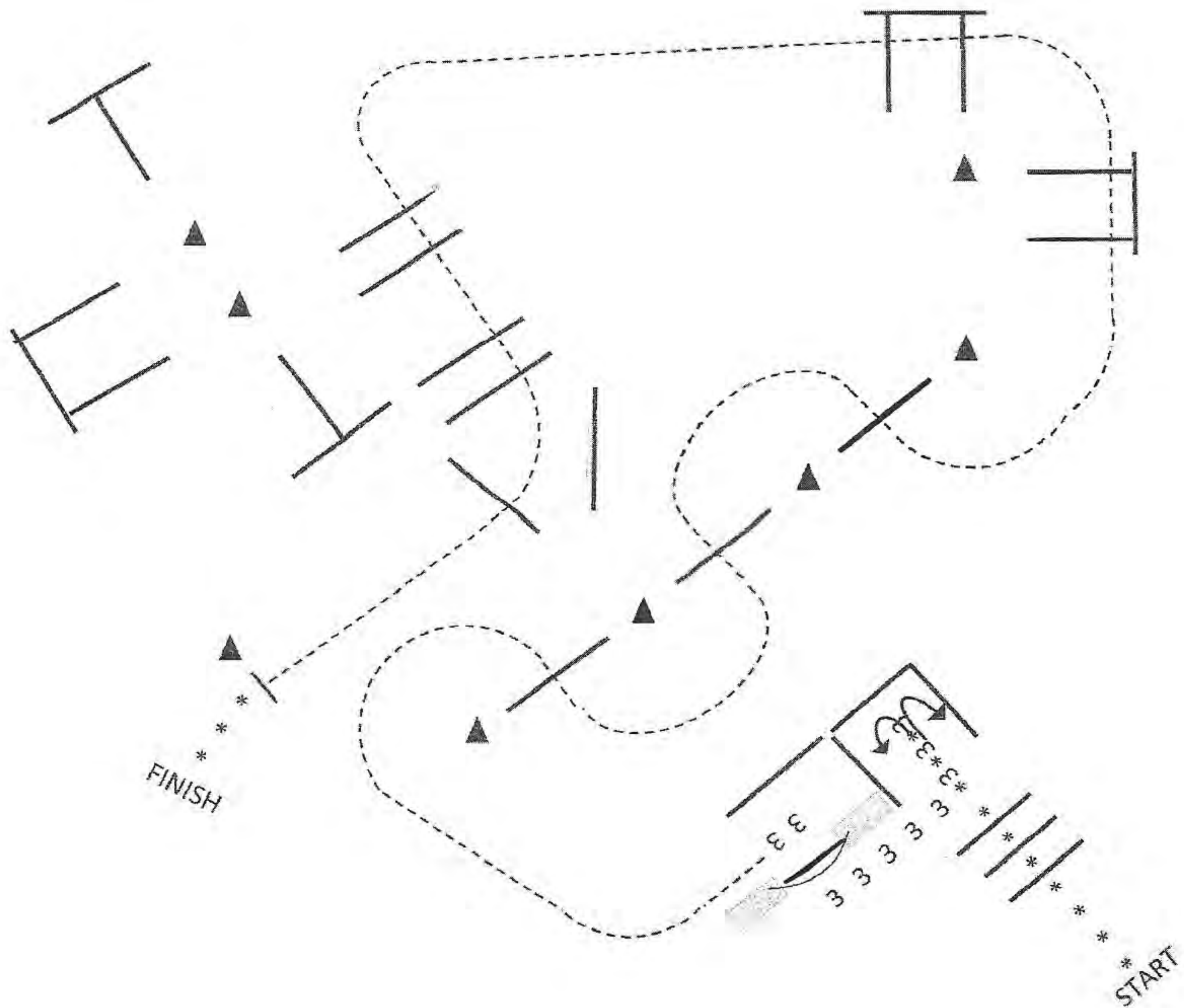

RANCH TRAIL 2022

ALL CLASSES 16 - 19

- WALK IN AND MOUNT YOUR HORSE WITH OR WITHOUT BLOCK
- WALK TO LOG AND SIDE PASS LEFT
- WALK FORWARD, TURN 360 DEGREES EACH WAY
- EXTEND TROT TO ROPE POST
- DRAG LOG AROUND CONES AND REPLACE ROPE (SPEED AND GATE RIDERS CHOICE)
- OPEN AND AM RIDERS ONLY . **All others do not drag, trot around cones.
- TROT OVER POLES AND THROUGH CONES
- LOPE (LL) OVER LOG
- CHANGE LEADS, LOPE (RL) OVER LOG TO GATE
- OPEN GATE, WALK THROUGH, CLOSE GATE
- BACK TO LOG, WALK FORWARD, OVER BRIDGE AND LOGS AND OUT

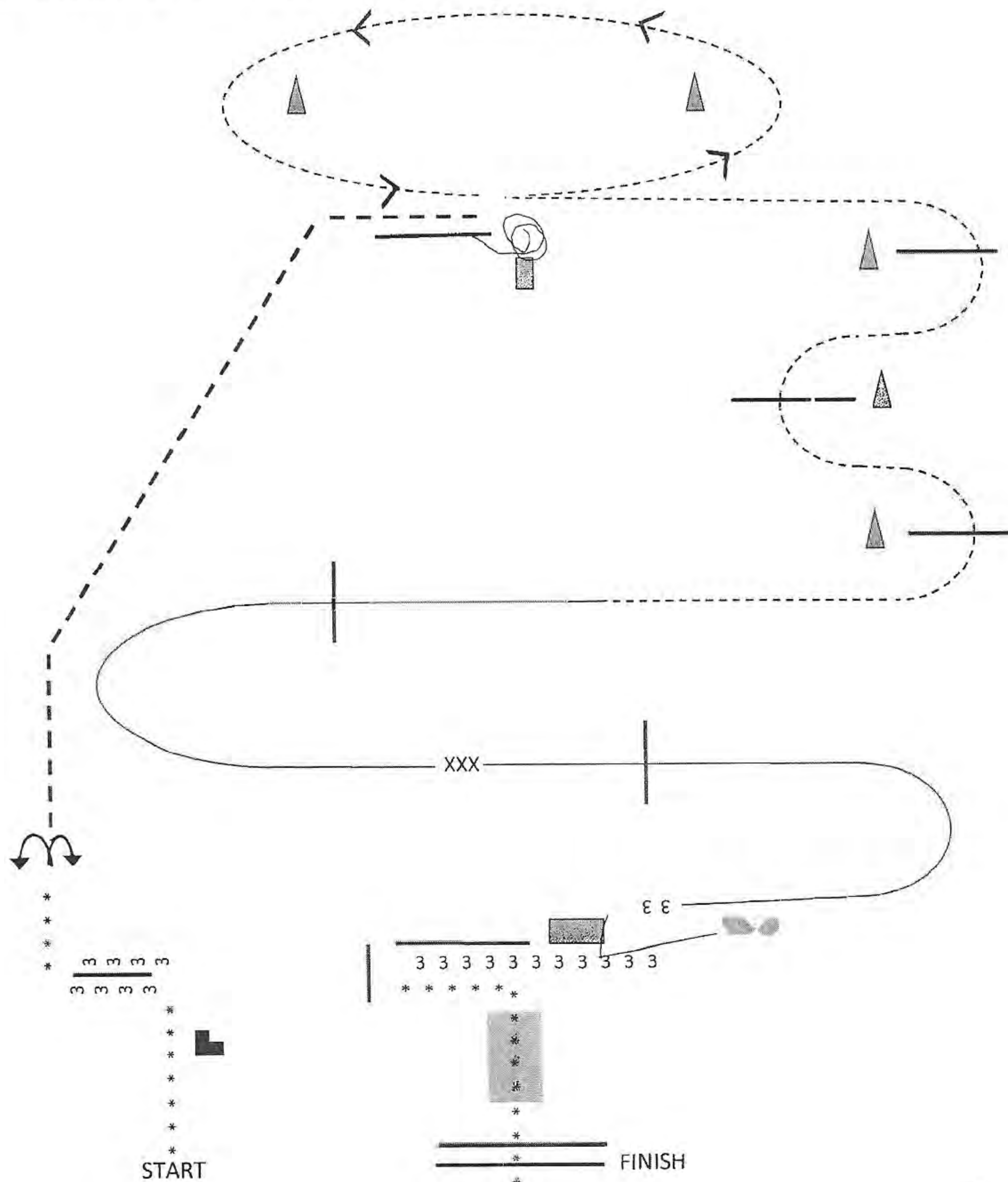

- ❑ **In the Ring**— Exhibitors enter arena and remain collectively for the entire class. Exhibitors are to enter the arena at the walk. Trot at the marker and line up at the discretion of the ringmaster.
- ❑ **In and Out of the Ring**— Exhibitors enter arena one at a time and are excused at the completion of their pattern.
- ❑ **At the Gate**— Exhibitors enter arena one at a time and are gathered in arena for final inspection as a collective group.

Showmanship

PATTERN G • LEVEL 1

Exhibitors are to complete the pattern on the side of the marker as indicated in the drawing

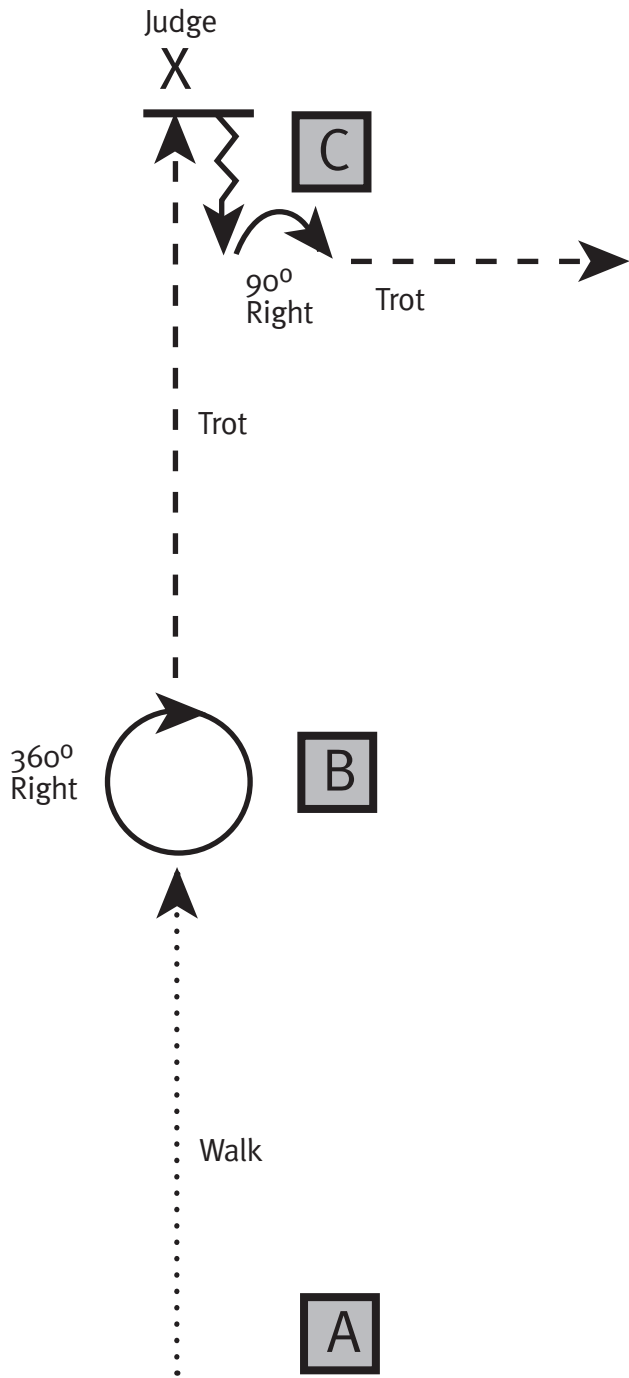

Be ready at marker A.

Walk to marker B. Stop.

Perform a 360-degree (1) haunch turn to the right. Stop.

Trot to marker C. Stop.

Set up for inspection.

After dismissal, back four steps.

Perform a 90-degree turn to the right and trot into the completion line as directed by the ringmaster or exit at the trot.

	Stop / Halt
	Canter
	Trot
	Walk
	Back
	Marker
	Lineup

Showmanship

PATTERN B • LEVEL 1

Exhibitors are to complete the pattern on the side of the marker as indicated in the drawing

Be ready at marker A.

Walk from marker A to marker B.

Trot from marker B to marker C.

Stop at marker C and set up for inspection.

When dismissed, back four steps.

Perform a 90-degree turn and trot to marker D as drawn. Stop.

Hesitate for several seconds and then trot to new lineup as directed by the ringmaster or exit at the trot.

- ❑ **In the Ring**— Exhibitors enter arena and remain collectively for the entire class. Exhibitors are to enter the arena at the walk. Trot at the marker and line up at the discretion of the ringmaster.
- ❑ **In and Out of the Ring**— Exhibitors enter arena one at a time and are excused at the completion of their pattern.
- ❑ **At the Gate**— Exhibitors enter arena one at a time and are gathered in arena for final inspection as a collective group.

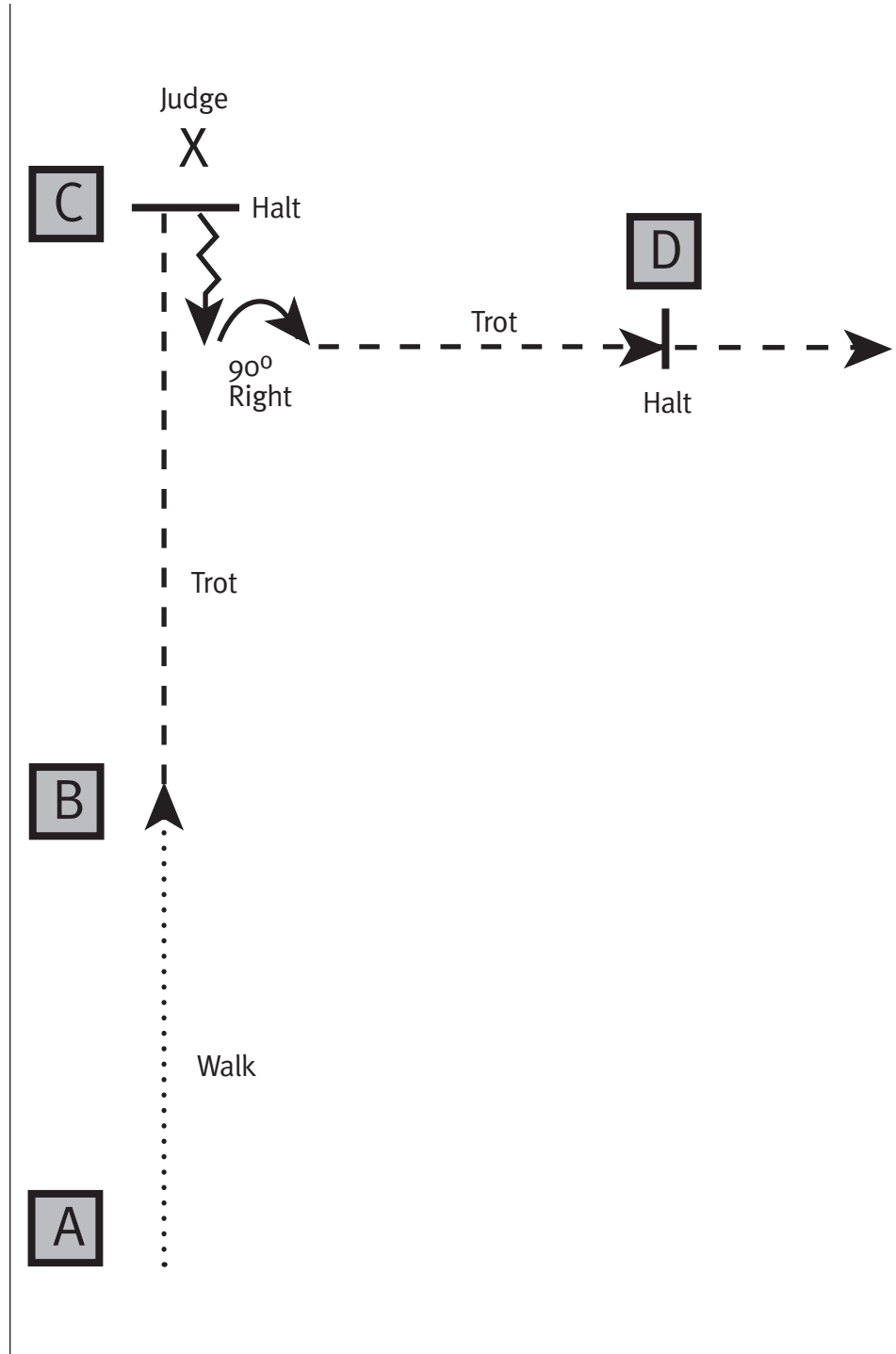
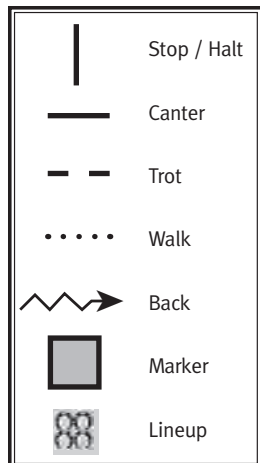

- ❑ **In the Ring**— Exhibitors enter arena and remain collectively for the entire class. Exhibitors are to enter the arena at the walk. Trot at the marker and line up at the discretion of the ringmaster.
- ❑ **In and Out of the Ring**— Exhibitors enter arena one at a time and are excused at the completion of their pattern.
- ❑ **At the Gate**— Exhibitors enter arena one at a time and are gathered in arena for final inspection as a collective group.

Showmanship

PATTERN A • LEVEL 1

Exhibitors are to complete the pattern on the side of the marker as indicated in the drawing

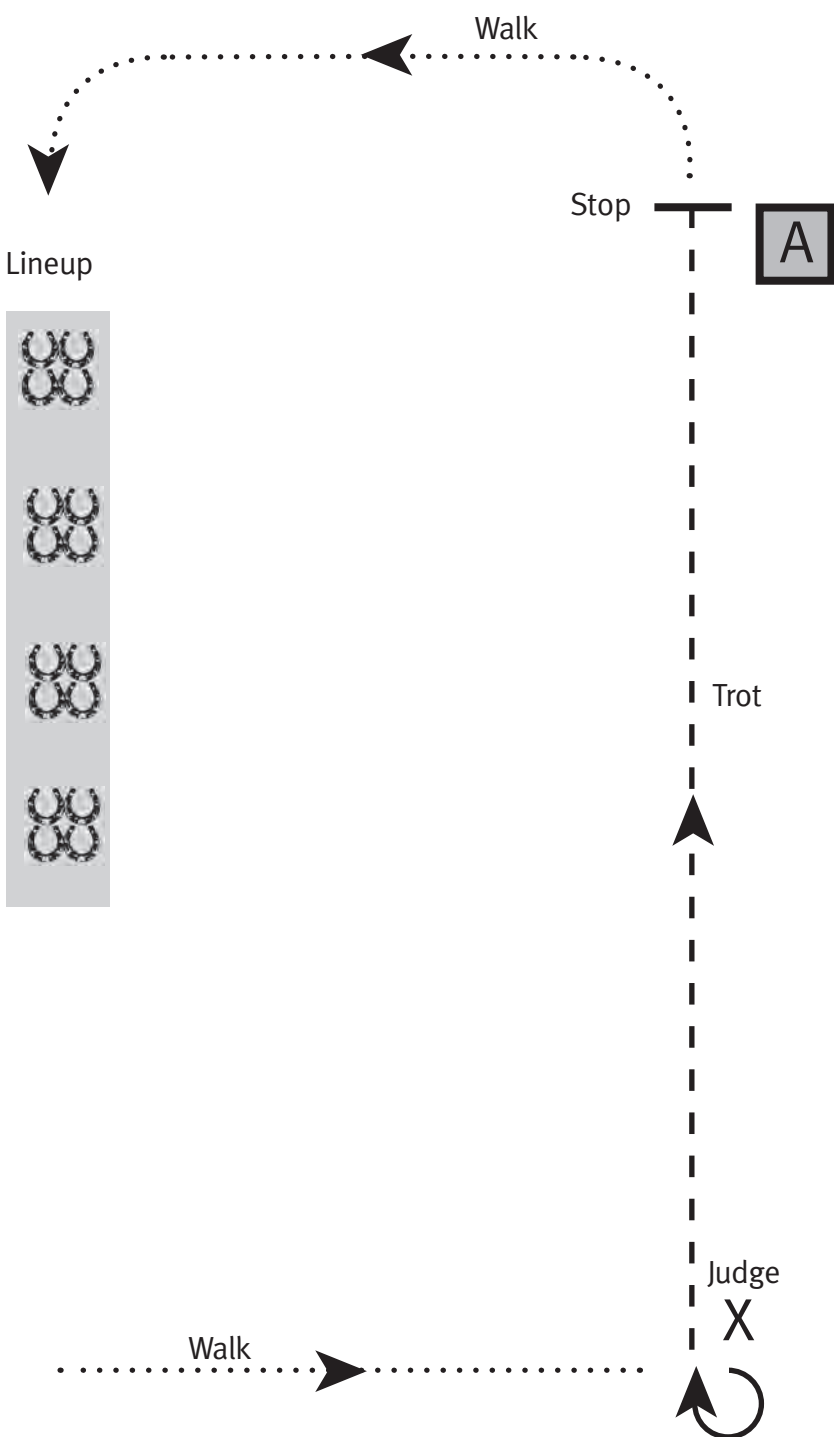

Walk to the judge and set up.

When excused, make a 3/4 turn.

Trot a straight line as drawn in the pattern and stop beside marker A.

Stop.

Walk back to lineup at the direction of the ringmaster or exit at the walk.

	Stop / Halt
—	Canter
- -	Trot
.....	Walk
~>	Back
■	Marker
🐎🐎	Lineup

Western Horsemanship

LEVEL 1 • PATTERN B • Tests 1,2,3,6

The drawn description of this pattern is only intended for the general depiction of the pattern. Exhibitors should utilize the arena to best exhibit their horses.

Be ready at marker A.

Lope right lead to marker B.
Stop.

Execute a 3/4 turn on the hindquarters to the left.

Lope left lead to marker C.

Stop and back approximately ten feet.

Return to lineup at the jog or exit arena at the jog.

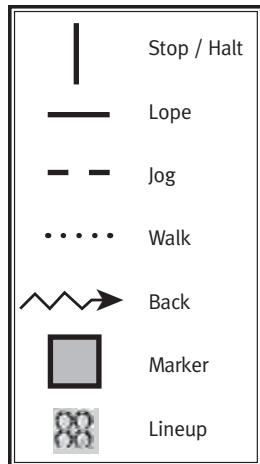

This pattern may only be used for:

- 13 & Under
- 14 - 18
- 18 & Under
- 19 & Over

If used at a Regional or National Show, pattern may not be run from the lineup.

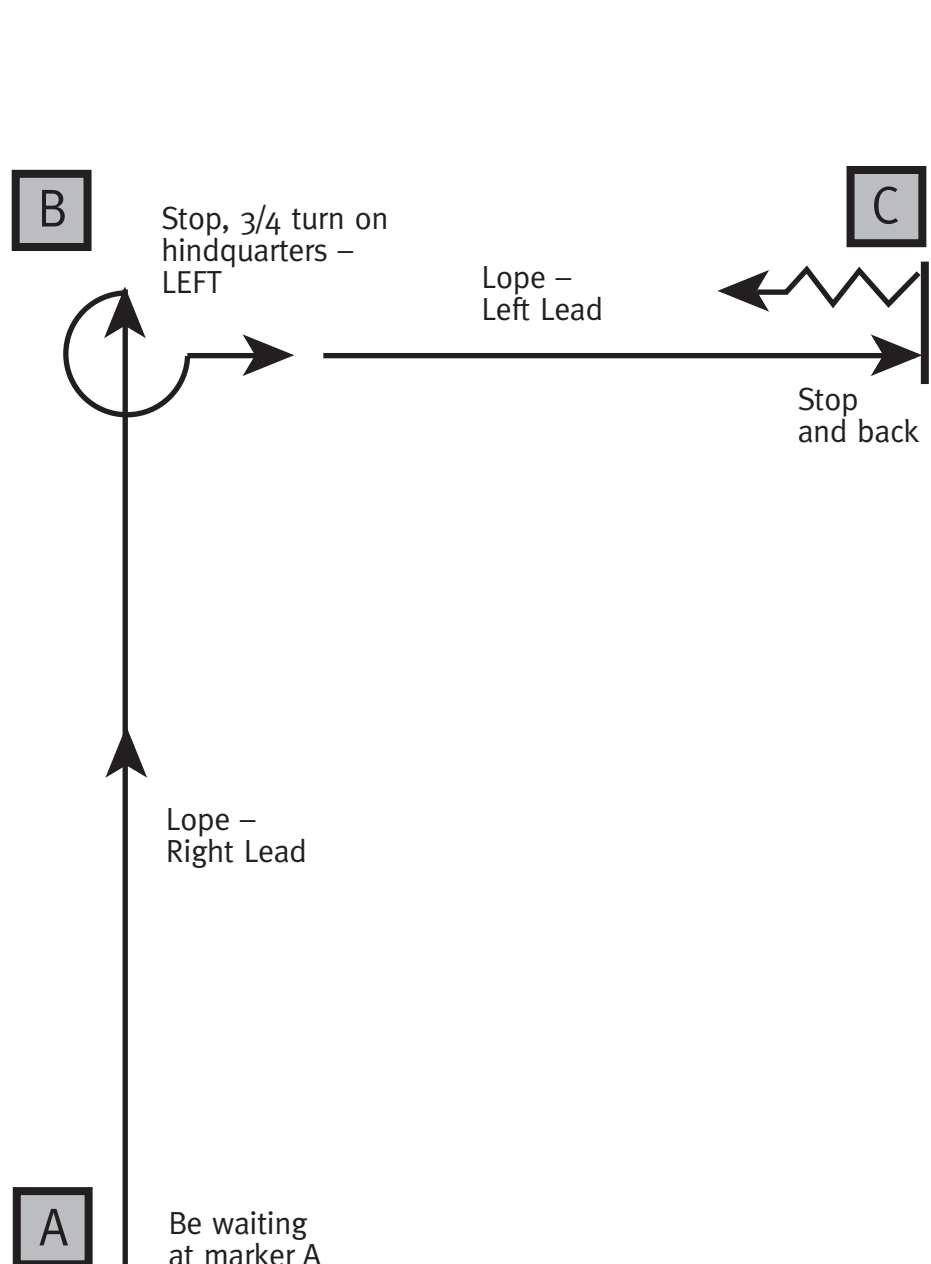

Western Horsemanship

LEVEL 1 • PATTERN A • Tests 1,2,6

*The drawn description of this pattern is only intended for the general depiction of the pattern.
 Exhibitors should utilize the arena to best exhibit their horses.*

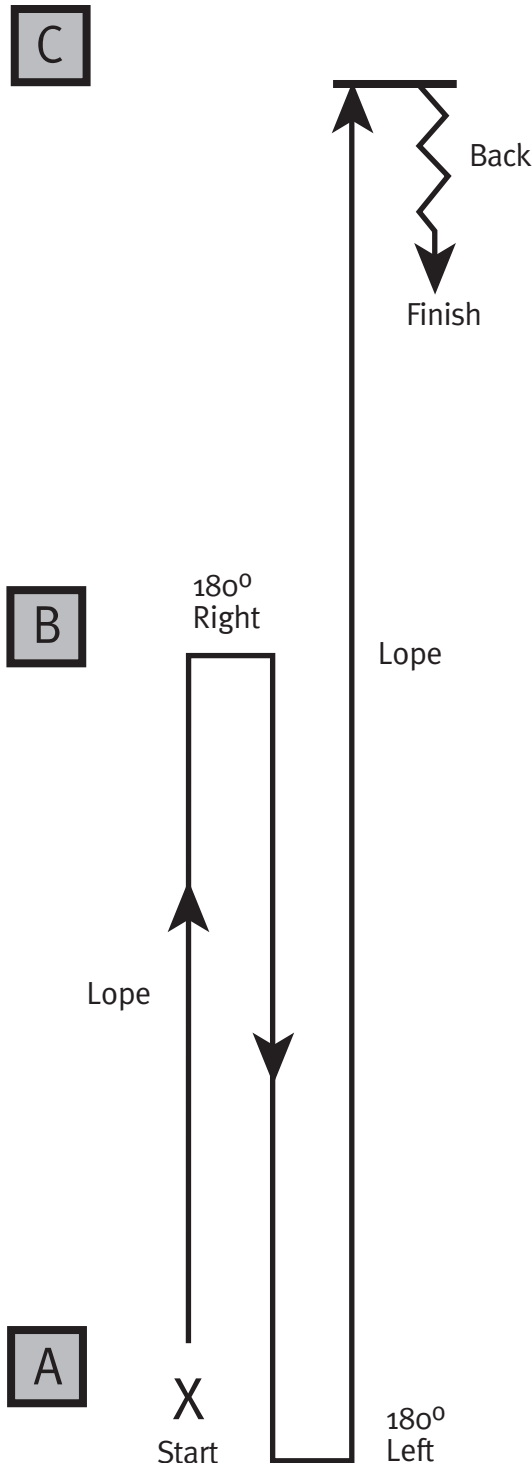

Be ready at Marker A.

Starting at Marker A, lope left lead to Marker B. Stop.

At Marker B, turn 180-degrees on hindquarters right.

Lope right lead to Marker A.

Stop at Marker A, and turn 180-degrees on hindquarters left.

Lope left lead to Marker C.

Stop at Marker C and back approximately ten feet.

After completing pattern, jog to far end of arena and form a new line or exit arena at the jog.

	Stop / Halt
—	Lope
- -	Jog
••••	Walk
~>	Back
■	Marker
⊞	Lineup

This pattern may only be used for:

- 13 & Under
- 14 - 18
- 18 & Under
- 19 & Over

If used at a Regional or National Show, pattern may not be run from the lineup.

Western Horsemanship

LEVEL 1 • PATTERN F • Tests 1,2,3,4

The drawn description of this pattern is only intended for the general depiction of the pattern. Exhibitors should utilize the arena to best exhibit their horses.

Be ready at marker A.

Jog from marker A to marker B.

Lope a circle on the right lead.

Continue out of the circle at a lope and simple change (walk or jog) to the left lead before marker C.

Lope a left circle on left lead at marker C.

Continue on the left lead to marker D.

Stop and back ten feet.

Return to the lineup at the jog or exit the arena at the jog.

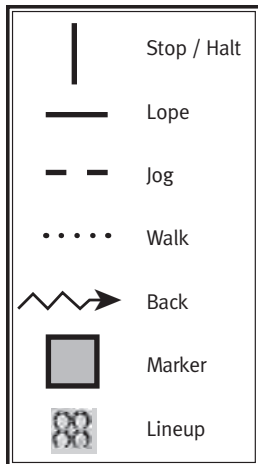

This pattern may only be used for:

- 13 & Under
- 14 - 18
- 18 & Under
- 19 & Over

If used at a Regional or National Show, pattern may not be run from the lineup.

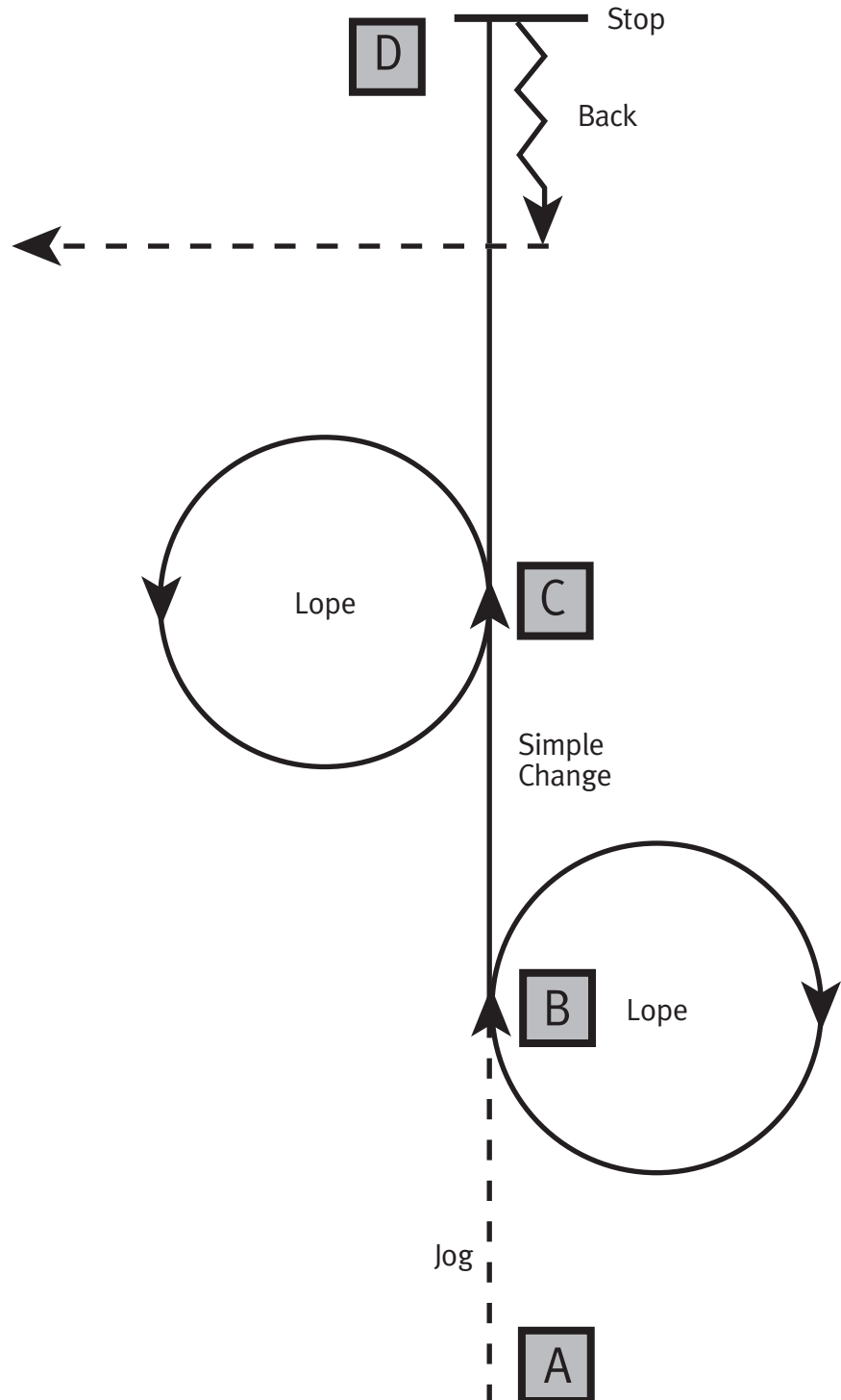

Hunter/Jumping Seat

LEVEL 1 • PATTERN E • EQUITATION – Tests 1,5

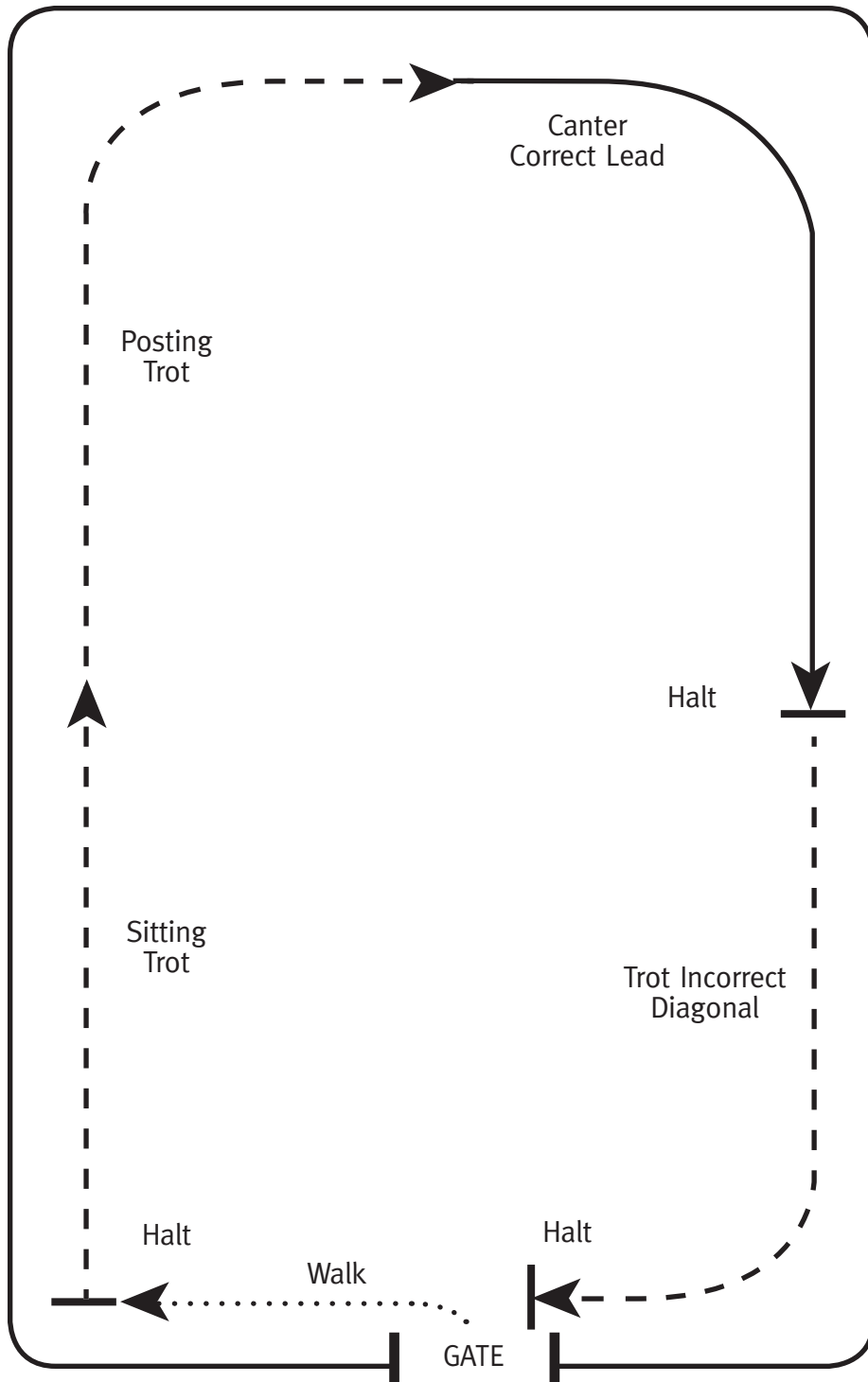

Enter arena at a walk. Halt.

Pick up a sitting trot.

Change to posting trot, correct diagonal.

Canter correct lead. Halt.

Trot on the incorrect diagonal to gate.

Halt. Exit at a walk or return to the lineup.

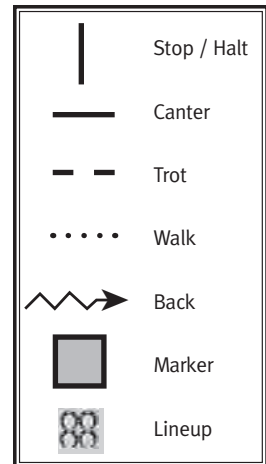

This pattern may only be used for:

- 13 & Under
- 14 - 18
- 18 & Under
- 19 & Over

If used at a Regional or National Show, pattern may not be run from the lineup.

Saddle Seat

LEVEL 1 • PATTERN C • Tests 6,10

From the lineup, trot down the right hand straightaway showing two changes of diagonal. Begin on the right diagonal. Continue trotting to the center of the end. Halt.

Canter a circle on the left lead. Halt.

Trot from the center of the end down the opposite straightaway on the right diagonal. Return to the lineup without stopping, or continue to the exit at the trot.

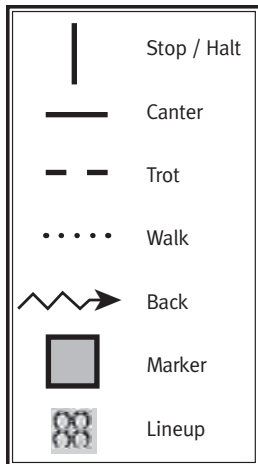

This pattern may only be used for:

- 13 & Under
- 14 - 18
- 18 & Under
- 19 & Over

If used at a Regional or National Show, pattern may not be run from the lineup.

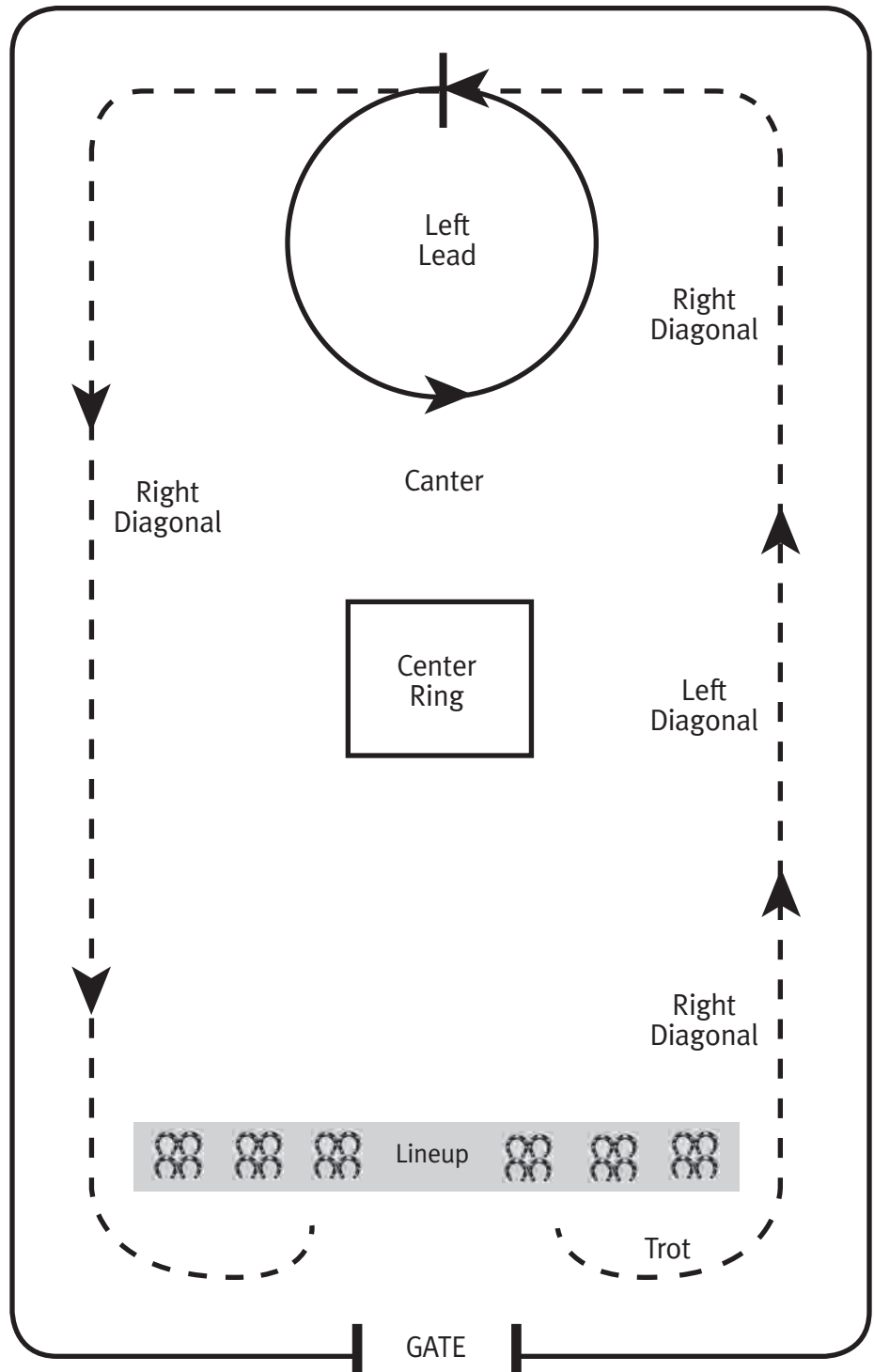

Classes 136 Arabian Open 137 Half-Arabian Open

RANCH RIDING - PATTERN 6

LEGEND

.....	Walk
....	Extended Walk
- - -	Trot
- - - -	Extended Trot
— — —	Lope
— — — —	Extended Lope
////	Back
\\	Lead Change

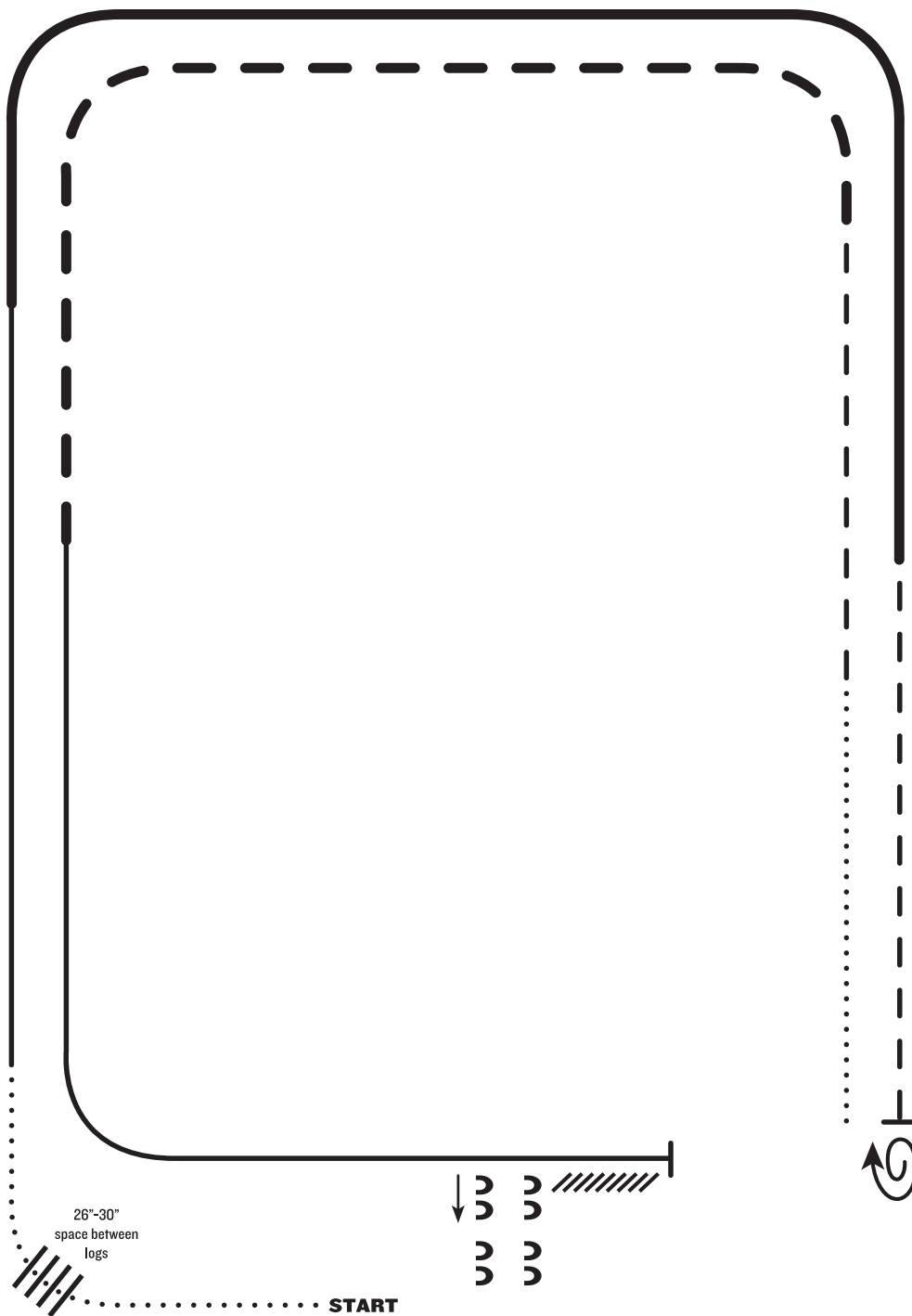

1. Walk
2. Walk over logs
3. Lope right lead
4. Extended lope right lead
5. Trot
6. Stop, 1/2 turn right
7. Walk
8. Trot
9. Extended trot
10. Lope left lead
11. Stop and back
12. Side pass right

Note: The drawn description of this pattern is only intended for the general depiction of the pattern. Exhibitors should utilize the arena space to best exhibit their horses.

Classes 89 Arabian Open 90 Half-Arabian Open

PATTERN 6

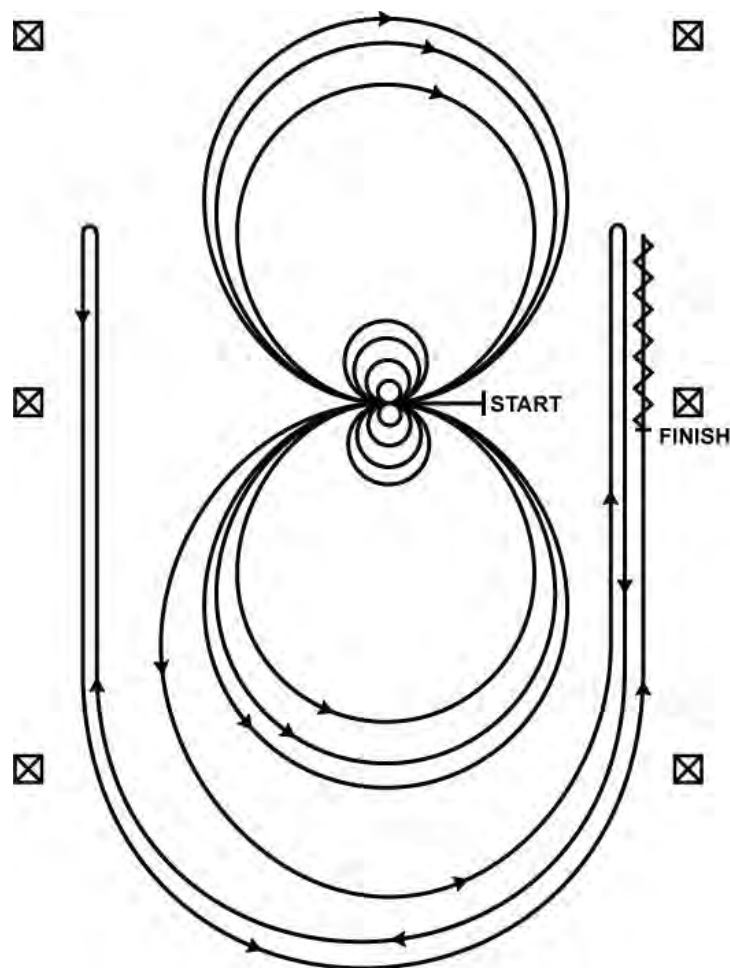

Horses may walk or trot to the center of arena. Horses must walk or stop prior to starting the pattern. Beginning at the center of the arena facing the left wall or fence.

1. Complete four spins to the right. Hesitate.
2. Complete four spins to the left. Hesitate.
3. Beginning on the left lead, complete three circles to the left: the first two circles large and fast; the third circle small and slow. Change leads at the center of the arena.
4. Complete three circles to the right: the first two circles large and fast; the third circle small and slow. Change leads at the center of the arena.
5. Begin a large fast circle to the left but do not close this circle. Run up the right side of the arena past the center marker and do a right rollback at least twenty feet (six meters) from the wall or fence—no hesitation.
6. Continue back around previous circle but do not close this circle. Run up the left side of the arena past center marker and do a left rollback at least twenty feet (six meters) from the wall or fence—no hesitation.
7. Continue back around previous circle but do not close this circle. Run up the right side of the arena past the center marker and do a sliding stop at least twenty feet (six meters) from the wall or fence. Back up at least ten feet (three meters). Hesitate to demonstrate the completion of the pattern. Rider must drop bridle to the designated judge or steward as designated by the judge.

Classes 140 Arabian ATR 141 Half-Arabian ATR

PATTERN 8

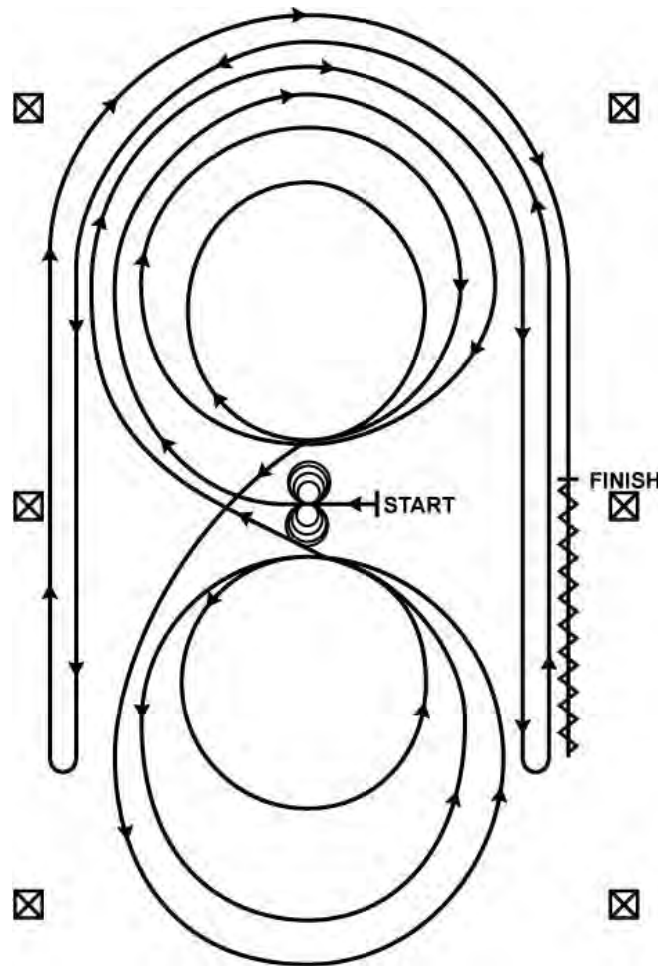

Horses may walk or trot to the center of arena. Horses must walk or stop prior to starting the pattern. Beginning at the center of the arena facing the left wall or fence.

1. Complete four spins to the left. Hesitate.
2. Complete four spins to the right. Hesitate.
3. Beginning on the right lead, complete three circles to the right: the first circle large and fast; the second circle small and slow; the third circle large and fast. Change leads at the center of the arena.
4. Complete three circles to the left: the first circle large and fast; the second circle small and slow; the third circle large and fast. Change leads at the center of the arena.
5. Begin a large fast circle to the right but do not close this circle. Run straight down the right side of the arena past the center marker and do a left rollback at least twenty feet (six meters) from the wall or fence—no hesitation.
6. Continue back around the previous circle but do not close this circle. Run down the left side of the arena past the center marker and do a right rollback at least twenty feet (six meters) from the wall or fence—no hesitation.
7. Continue back around the previous circle but do not close this circle. Run down the right side of the arena past the center marker and do a sliding stop at least twenty feet (six meters) from the wall or fence. Back at least ten feet (three meters). Hesitate to demonstrate the completion of the pattern. Rider must drop bridle to the designated judge or steward as designated by the judge.

Class 142 Medal JTR

PATTERN 10

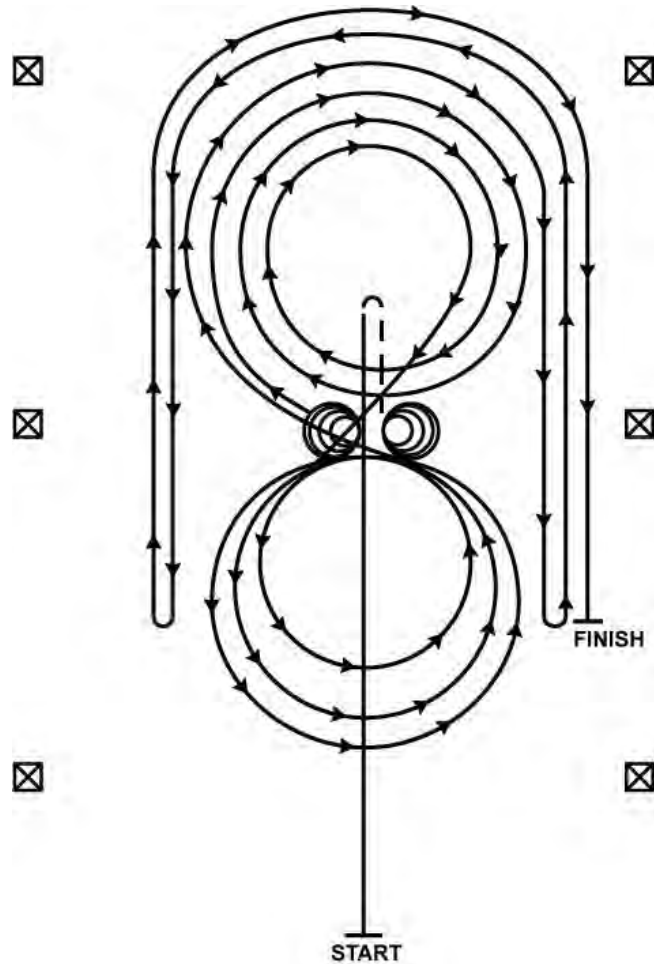

1. Run past the center marker and do a sliding stop. Back up to the center of the arena or at least ten feet (three meters). Hesitate.
2. Complete four spins to the right. Hesitate.
3. Complete four and one quarter spins to the left so that the horse is facing the left wall or fence. Hesitate.
4. Beginning on the right lead, complete three circles to the right: the first two circles large and fast, the third circle small and slow. Change leads at the center of the arena.
5. Complete three circles to the left: the first circle small and slow, the next two circles large and fast. Change leads at the center of the arena.
6. Begin a large fast circle to the right but do not close this circle. Run down the right side of the arena past the centermarker and do a left roll back at least twenty feet (six meters) from the wall or fence—no hesitation.
7. Continue back around the previous circle but do not close this circle. Run down the left side of the arena past the center marker and do a right roll back at least twenty feet (six meters) from the wall or fence—no hesitation.
8. Continue back around previous circle but do not close this circle. Run down the right side of the arena past the center marker and do a sliding stop at least twenty feet (six meters) from the wall or fence. Hesitate to demonstrate completion of the pattern.

Rider must drop the bridle to the designated judge or steward as designated by the judge.