

PIVOT

HEIGHT ADJUSTABLE TABLE

USER GUIDE

PIVOT

HEIGHT ADJUSTABLE TABLE

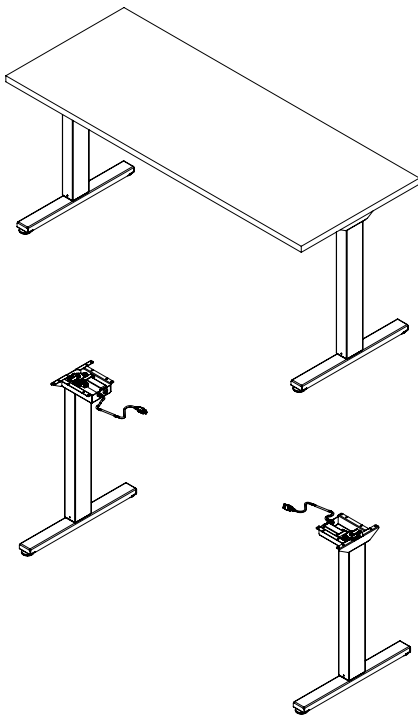

FEATURES

- Full table base (add your own work surface)
- Meets BIFMA X5.5 standards
- UL 962 approved
- Easy-order with one part number
- Lift capacity up to 250 lb.

TABLE OF CONTENTS

Parts Diagram	4-5
Independent Table	4
Table with Anti-Sag Bar	5
Safety Information	6-7
Assembly Instructions	8-11
Operation	12
Initialization and Reset	12
Handswitch Operation	12
Troubleshooting	13
Unit Errors	13
Technical Data	14
Warranty	15
Standards & Certifications	15

This manual explains how this sit-stand desk is assembled, used, and maintained. All sit-stand tables are subjected to functional and quality tests before leaving our facility.

PIVOT

PARTS DIAGRAM

INDEPENDENT TABLE

For tables up to 60"

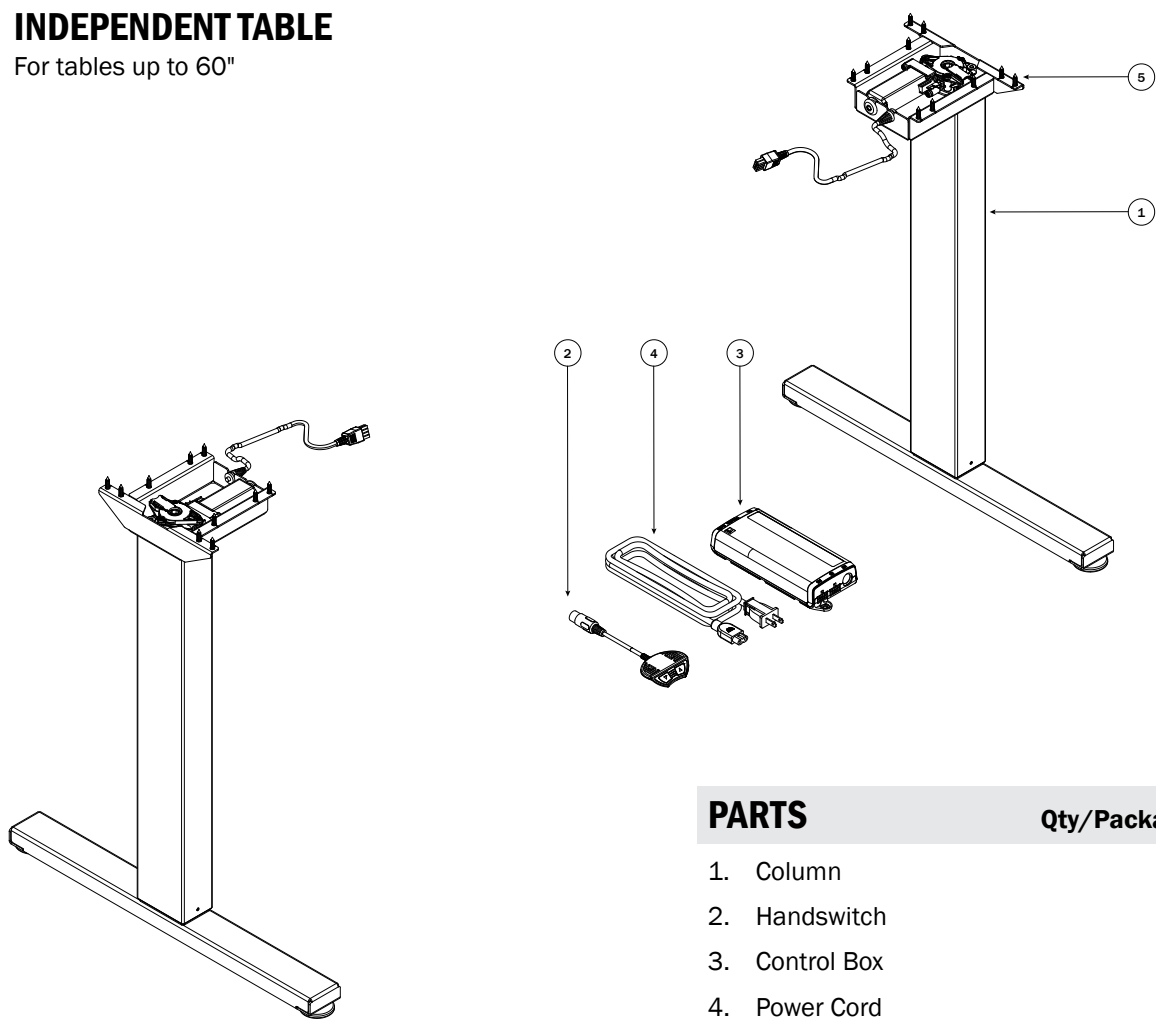

PARTS

Qty/Package

1.	Column	2
2.	Handswitch	1
3.	Control Box	1
4.	Power Cord	1
5.	#10 x 3/4" Screw	24

TABLE WITH ANTI-SAG BAR

For tables over 60"

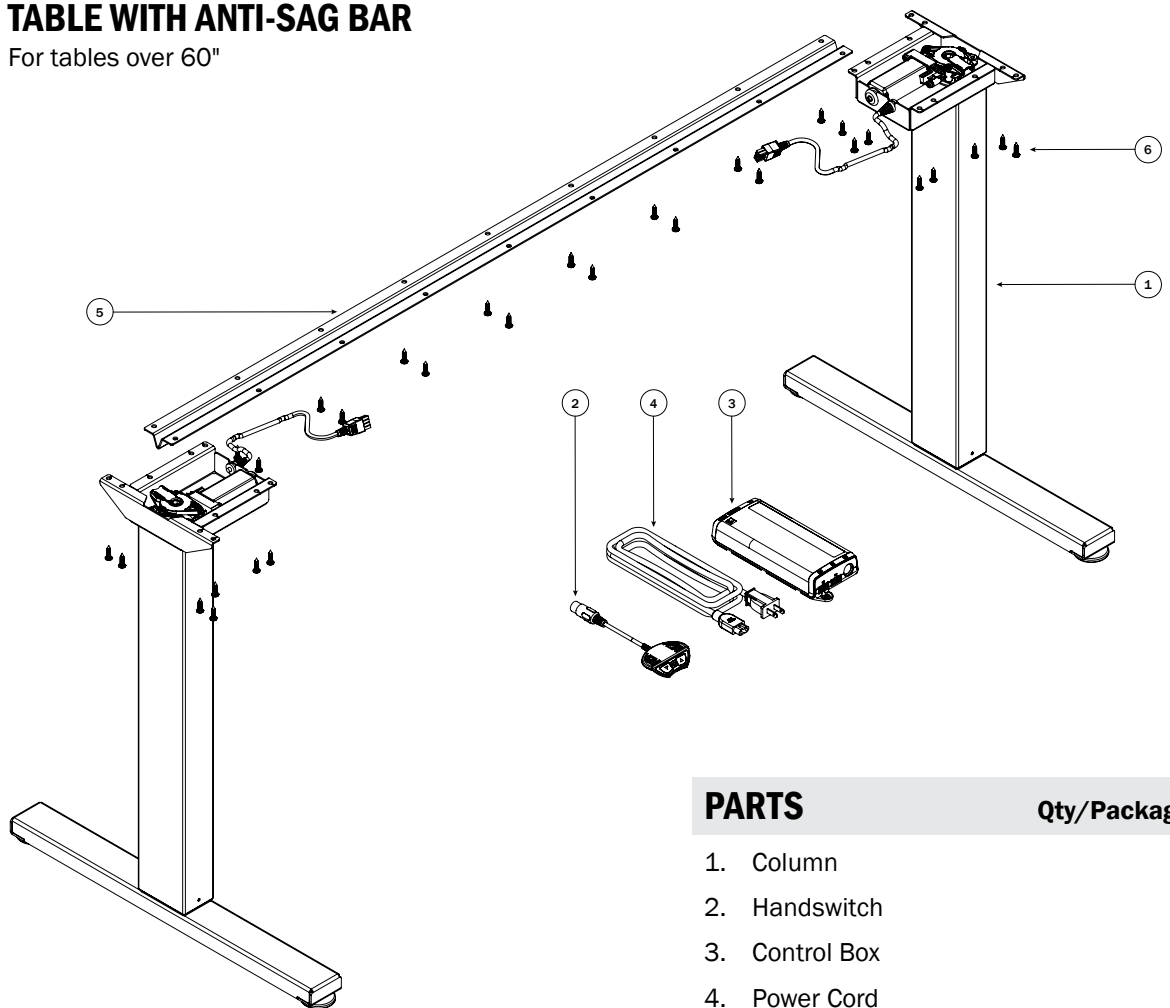

PARTS

Qty/Package

1.	Column	2
2.	Handswitch	1
3.	Control Box	1
4.	Power Cord	1
5.	Anti-Sag Bar	1
6.	#10 x 3/4" Screw	42

SAFETY INFORMATION

IMPORTANT SAFETY INSTRUCTIONS *Save these instructions.*

DANGER To reduce the risk of electric shock:

Always unplug this furnishing from the electrical outlet before cleaning.

WARNING: To reduce the risk of death, serious injury, or property damage, read and follow this safety information and the provided instructions when assembling this product. Do not change or replace components and accessories.

INSTALL ONLY APPROVED WORK SURFACES

This table system does not include a work surface (desktop). Work surface must be at least $\frac{3}{4}$ " thick and weigh no more than 5 lb. per square foot (For example, a 2'x6' desktop should weigh no more than 60 lb). Do not exceed a maximum weight for the desktop of 75 lb. To prevent table from tipping or collapsing, make sure the desk frame is not overloaded by the weight of tabletop and objects you plan to put on the table. If you are unsure, contact customer service.

KEEP AWAY FROM CHILDREN

This table system is not designed for use in homes or other areas accessible by small children. For indoor commercial office use only.

BE CAREFUL WHEN ADJUSTING DESK HEIGHT

Body parts and property can be caught between the moving work surface and an immobile obstacle (such as shelves, furniture, window sills, or walls). Keep at least one inch of clearance around desk and make sure nothing is in table's path for its entire range of motion.

Before raising or lowering:

- Check surroundings on all sides of desk are clear
- Make sure corded objects will not be pulled off table or cause other objects to fall
- Make sure desk power cord moves freely as desk moves up and down

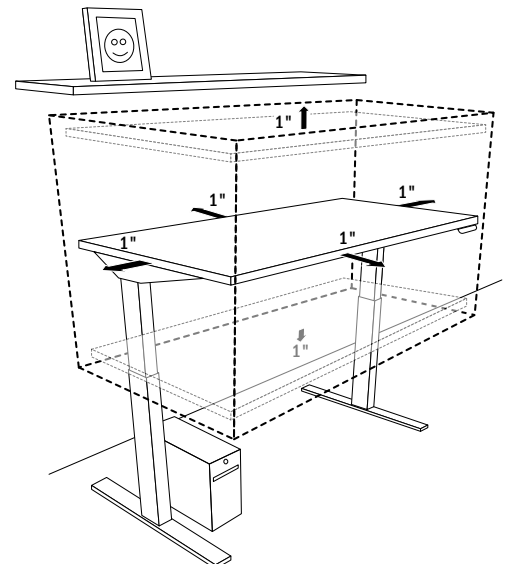

DO NOT OVERLOAD DESK

To prevent table from tipping or collapsing, make sure the desk frame is not overloaded by the weight of tabletop and objects on table. Evenly distribute load; excess loads near edges can reduce stability and lead to tip over.

- Do not exceed maximum load (including weight of desktop) of 250 lb. (113Kg)
- Do not exceed edge load of 25 lb. when positioning monitors or mounting accessories.
- Do not sit or stand on table

USE CARE WHEN MOVING DESK

- Clear objects and equipment from table before moving to reduce the risk of tipping over.
- Adjust the desk to its lowest height before moving
- To disconnect, remove plug from outlet
- Do not move a loaded desk

DO NOT OPEN ELECTRICAL COMPONENTS

Do not attempt to service table components. There are no user-serviceable parts inside the motor control units or table legs. If your table needs service, contact customer service. Never operate this table if it has a damaged cord or plug, if it is not working properly, or if it has been dropped or damaged.

KEEP TABLE FRAME DRY

Keep all electrical components away from water and high humidity. Clean only with a dry or slightly damp cloth. Do not spray cleaning solutions directly onto table system.

GROUNDING INSTRUCTIONS

This product is equipped with a cord having an equipment-grounding conductor and a grounding plug. **Use only the cord provided.** Make sure that the product is connected to an outlet having the same configuration as the plug (as shown in Illustration A) that is properly installed and grounded in accordance with all local codes and ordinances.

Do not modify the plug provided with the product – if it will not fit the outlet, have a proper outlet installed by a qualified electrician.

No adapters are to be used with this product.
Keep cord away from heated surfaces.

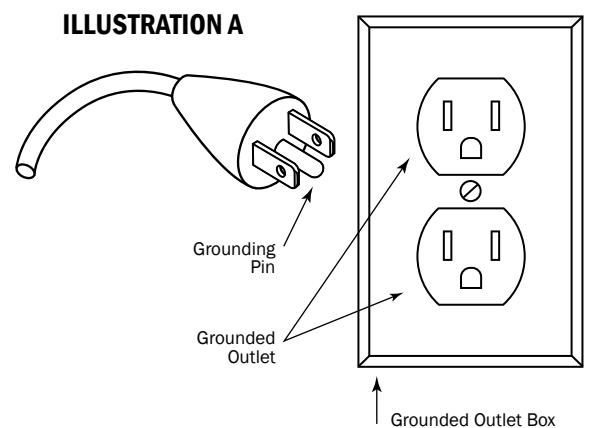

ASSEMBLY INSTRUCTIONS

The assembly of the table frame to be made in accordance with this manual.
Changes to the table frame or improper use may affect the safety, function, and life of your product.

ASSEMBLY OVERVIEW

1. Assemble the columns to the top
2. Fasten the control box and handswitch to the table top
3. Connect the motor cables to the control box
4. Connect the handswitch (HS) cable to the control box
5. Connect the supplied power cord (AC) to the control box
6. Attach all cables to the table frame or on the underside of the table top

If you have any difficulty assembling this unit, or need to order replacement parts, please contact our Customer Service department. Use the parts diagrams on page 4-5 as a reference.

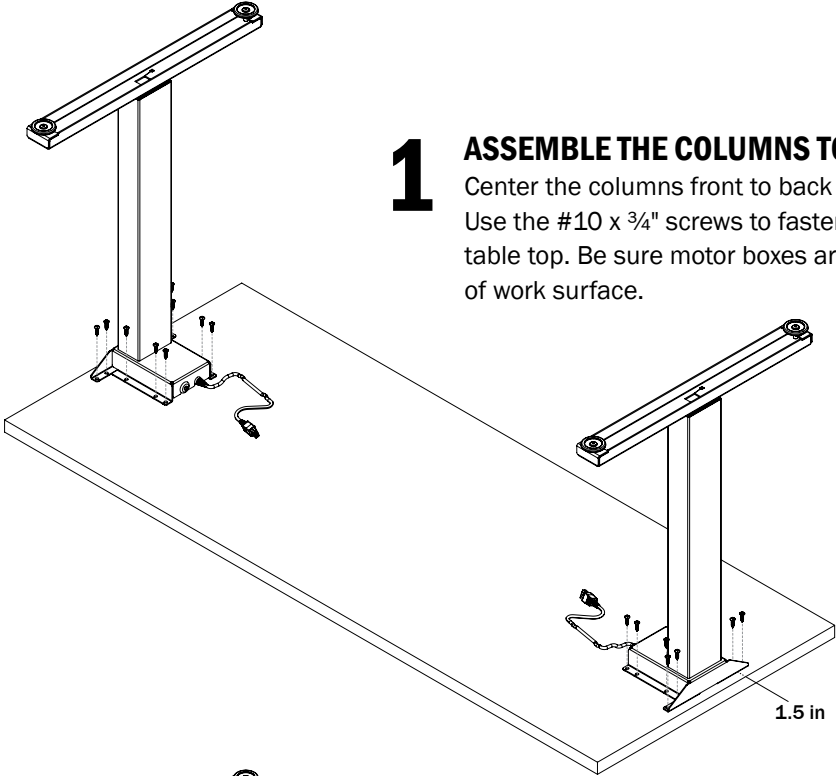

1 ASSEMBLE THE COLUMNS TO THE WORK SURFACE

Center the columns front to back on the work surface. Use the #10 x 3/4" screws to fasten the top support onto the table top. Be sure motor boxes are mounted 1.5" from edge of work surface.

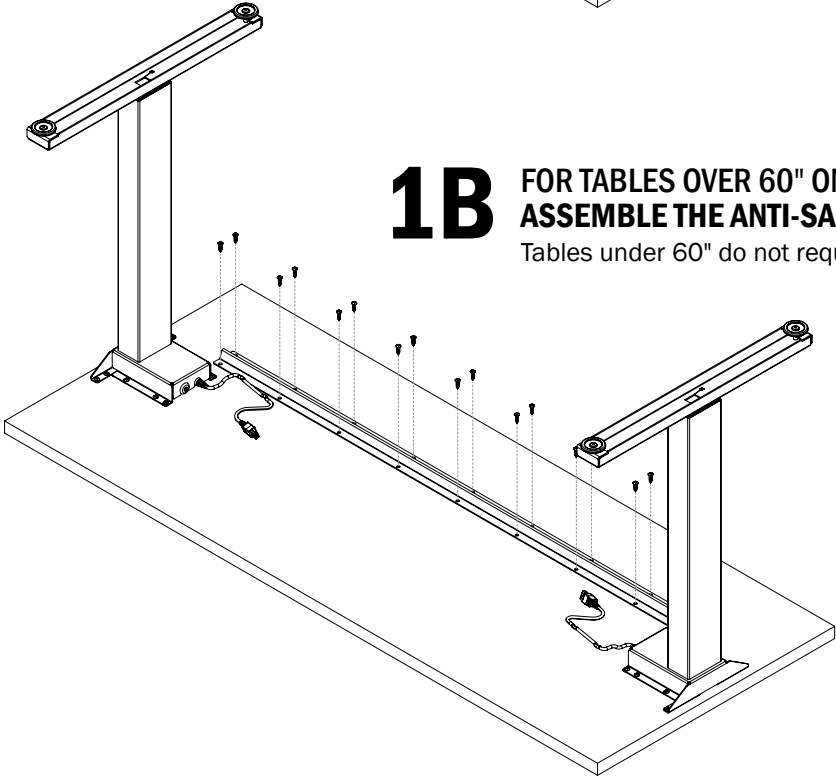

1B FOR TABLES OVER 60" ONLY ASSEMBLE THE ANTI-SAG BAR TO THE WORK SURFACE

Tables under 60" do not require anti-sag bar.

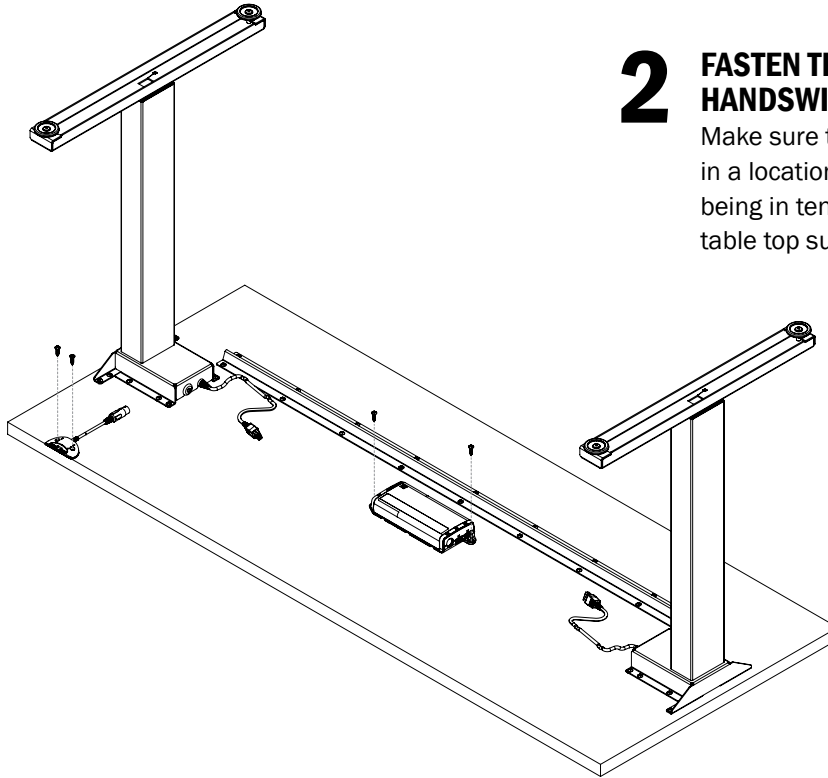

2 FASTEN THE CONTROL BOX AND HANDSWITCH TO THE TABLE TOP

Make sure the control box and handswitch are fastened in a location where all the cables will connect without being in tension. Be sure to use approved screws per the table top supplier.

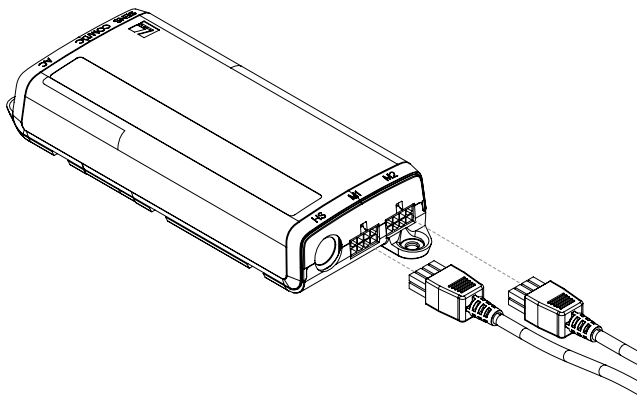

3 CONNECT THE MOTOR CABLES TO THE CONTROL BOX

The motor cable plug-connection has to click into place.

Connections to the control box:
M1-M2 = Connectors for the columns
HS = Connectors for the handset
AC = Connector for the power cord (3-pin)

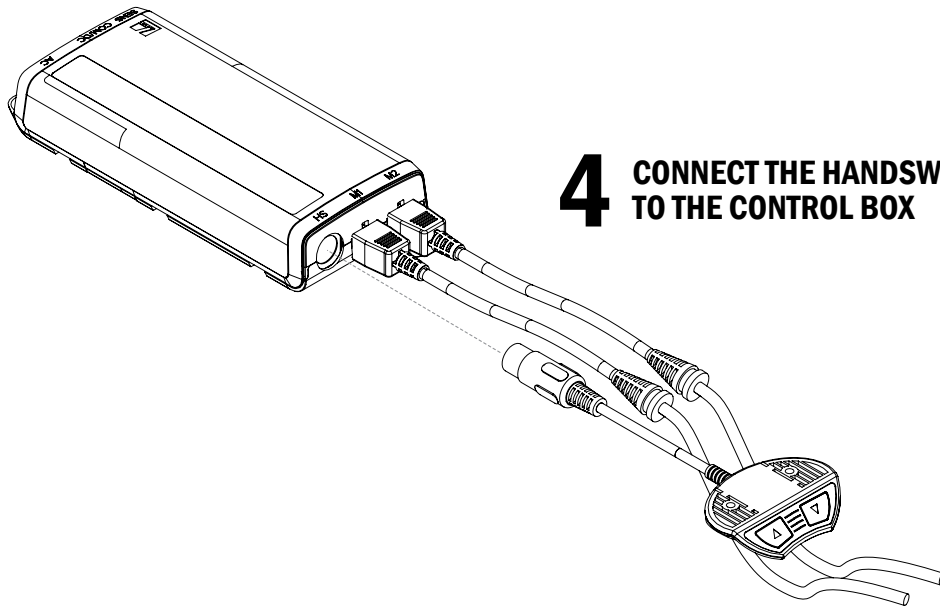

4 CONNECT THE HANDSWITCH (HS) CABLE TO THE CONTROL BOX

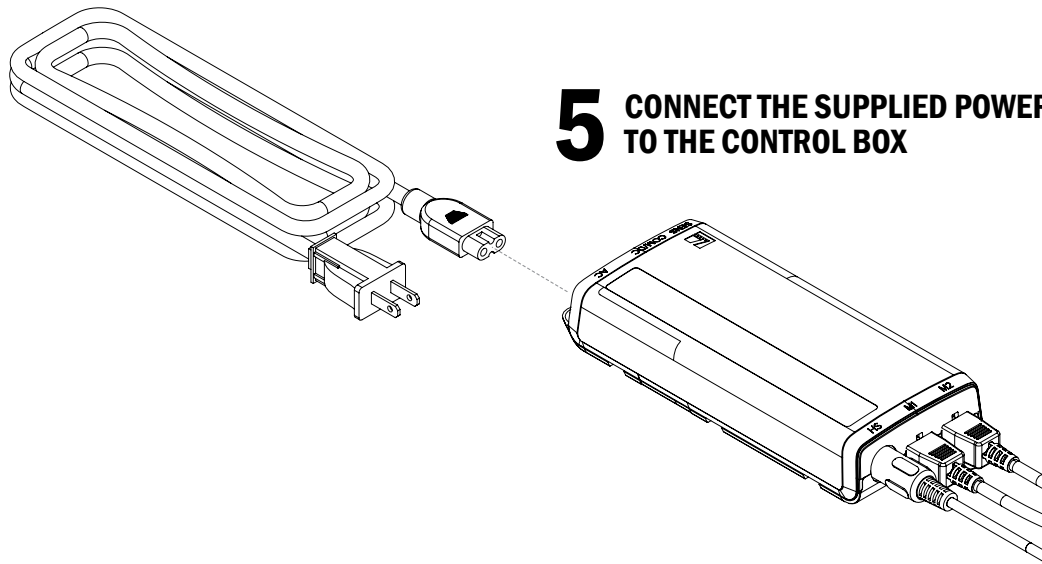

5 CONNECT THE SUPPLIED POWER CORD (AC) TO THE CONTROL BOX

6 ATTACH ALL CABLES TO THE TABLE FRAME OR ON THE UNDERSIDE OF THE TABLE TOP

Attach cables in order to avoid any damage during operation.
 Never wrap cables and/or cords around the columns.

OPERATION INFORMATION

INITIALIZATION/RESET

The desk must be initialized/reset after any of the following:

- After assembly
- After disconnection from the power supply
- After any impact on the table top.

To initialize/reset, move the table to the lowest position by pressing the DOWN button on the handswitch until the columns reach the lowest position. Press the DOWN button again until the table moves slightly back up to the operation zero point. Release the DOWN button. If the button is released too soon, the table legs will not move up. Repeat the reset process.

The control box is programmed with a parameter file which controls the table legs' lower and upper travel limits. **Under no circumstance should a control box from one table be moved to another.**

NORMAL HANDSWITCH OPERATION (for all handswitch types)

By pressing the UP or DOWN buttons, the table will move up or down to the desired position. Once the desired position is reached, let go of the UP or DOWN button. The table legs will stop once they reach the lower or upper height limits.

TROUBLESHOOTING

UNIT

ERROR CODE	SOURCE	SOLUTION
Table does not move	No power supply	Plug in the power cord or check the connection on the control box
	No connection or a loose connection to the drives	Verify the plug connections of the motor cable to the control box
	No connection or a loose connection to the handswitch	Verify the plug connections of the motor cable to the control box
	Max lifting capacity is exceeded	Reduce the weight or load on the desktop
	Max time limit is exceeded	Control is activated automatically after approx. 9 minutes
	Defective drive	Contact customer service
	Defective control box	Contact customer service
	Defective handswitch	Replace the handswitch
Table moves down at a slow rate	Control box expects new reset	Reset control box. (See page 12)
During operation, tables moves at a slow rate	Max lifting capacity is exceeded	Reduce weight
Table moves on one side only briefly and then stops	No connection or a loose connection to the drives	Verify the plug connections of the motor cable to the control box and reset the control box
	Defective drive	Contact customer service

TECHNICAL DATA

GENERAL CONTROL BOX	
Power supply	120 VAC \pm 10% / 60 Hz
Standby power consumption, primarily	<0.3 W
Operating temperature	0-35°C
Protection class	IP 20
Maximum power output	240VA/24V
TWO-COLUMN FRAME WITH CONTROL BOX	
Maximum lift capacity	250 lb (\approx 113 kg / 1112N)
Adj. range, depending on version	View Illustration B
Maximum input current	5 A
Maximum duty cycle	30 sec. on / 9 min. off

ILLUSTRATION B

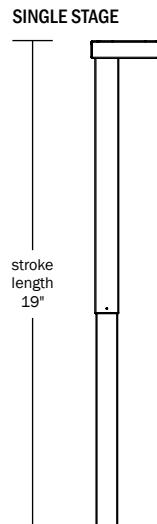

STANDARDS & CERTIFICATIONS

The drive system is tested according to the following standards:

UL 962

Issued: 2019/05/21 Ed: 4 Household and Commercial Furnishings

CSA C22.2#68

Issued: 2019/05/21 Ed: 8 (R2018)

Motor-Operated Appliances (Household and Commercial)

Meets BIFMA x5.5 2014.

WARRANTY

CONTACT YOUR SALES REPRESENTATIVE FOR WARRANTY INFORMATION



End of life cycle: Once product is disassembled, all steel components can be recycled at your local metal collector.

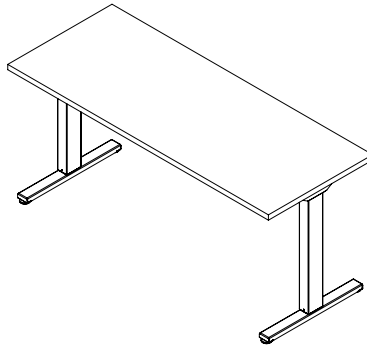

PIVOT

USER GUIDE